



# Cat<sup>®</sup>

## 302.7 CR

(WITH FIXED UNDERCARRIAGE)

### MINI EXCAVATOR

#### FEATURES:

The Cat<sup>®</sup> 302.7 CR Mini Excavator delivers power and performance in a compact size to help you work in a wide range of applications.

#### ALL DAY COMFORT

- Choose either a canopy or a sealed and pressurized cab which can be equipped with air conditioning, adjustable wrist rests, and a suspension seat option to help keep you working comfortably all day long.

#### EASY TO OPERATE

- Controls are easy to use and the intuitive Next Generation LCD monitor provides easy to read machine information. An advanced touchscreen monitor can also be equipped.

#### STICK STEER TRAVEL MODE

- Moving around the job site is even easier with the Cat Stick Steer option. Easily switch from traditional travel controls with levers and pedals to joystick controls to move the machine and to operate the blade. The benefit of less effort and improved control is in your hands!

#### BIG PERFORMANCE IN A COMPACT DESIGN

- Strong lift and dig performance helps you get the job done faster. The compact radius design lets you access and work in the tightest areas. Dig-to-blade and dozer blade float features allow for easy cleanup.

#### SAFETY ON THE JOB SITE

- Your safety is our top priority. The Cat mini excavator is designed to help keep you safe on the job. Courtesy work lights and a fluorescent retractable seat belt with optional seat belt reminder system are just a couple of the safety features we've built into the machine.

#### SIMPLE SERVICE FOR LESS DOWNTIME

- Maintenance is quick and easy on the Cat mini excavator. Routine check points are easy to access at ground level through the side doors. The unique tilt up cab or canopy lets you reach additional service areas when needed.

#### LOWER OPERATING COSTS

- Equipped with features such as auto idle, auto engine shutdown, and efficient hydraulics with a variable displacement pump, the Cat mini excavator was designed with reducing your operating costs in mind.

#### UNMATCHED DEALER SUPPORT

- Your Cat dealer is here to help you reach your business goals. From providing equipment solutions to operator training to service needs and beyond, your Cat dealer is ready to help.



# 302.7 CR Mini Excavator

## Specifications

### Engine

Engine Model	C1.1 Turbo	
<b>Net Power</b>		
ISO 9249, 80/1269/EEC	17.6 kW	23.6 hp
<b>Engine Power</b>		
ISO 14396	18.4 kW	24.7 hp
Bore	77.0 mm	3.0 in
Stroke	81.0 mm	3.2 in
Displacement	1.1 L	69.0 in <sup>3</sup>

- Meets U.S. EPA Tier 4 Final and EU Stage V emissions standards.
- Advertised power is tested per the specified standard in effect at the time of manufacture.
- Net power advertised is the power available at the flywheel when the engine is at the rated speed of 2,400 rpm and the engine is installed with the factory configured fan, air intake system, exhaust system and alternator with a minimum alternator load.

### Weights

Minimum Operating Weight with Canopy*	2560 kg	5,645 lb
Maximum Operating Weight with Canopy**	2925 kg	6,450 lb
Minimum Operating Weight with Cab*	2680 kg	5,909 lb
Maximum Operating Weight with Cab**	3050 kg	6,725 lb
EU: CE Plate Weight with Canopy***	2695 kg	5,942 lb
EU: CE Plate Weight with Cab***	2800 kg	6,174 lb

\*Minimum Weight is based on rubber tracks, operator, full fuel tank, standard stick, blade, no bucket and no extra counterweight.

\*\*Maximum Weight is based on steel tracks, operator, full fuel tank, long stick, blade, no bucket and extra counterweight.

\*\*\*CE Plate Weight is based on the most common EU configuration. Includes 75 kg (165 lb) operator, 100 kg (220 lb) counterweight, full fuel tank and excludes bucket.

### Weight Increase from Minimum Configuration

Cab	125 kg	276 lb
Counterweight (light)	100 kg	221 lb
Counterweight (extra)	250 kg	551 lb
Long Stick	15 kg	33 lb
Steel Tracks	100 kg	221 lb

### Travel System

Travel Speed – High	4.5 km/h	2.8 mph
Travel Speed – Low	2.6 km/h	1.6 mph
Maximum Traction Force – High Speed	15.6 kN	3,507 lbf
Maximum Traction Force – Low Speed	26.8 kN	6,025 lbf
Ground Pressure – Minimum Weight	24.2 kPa	3.5 psi
Ground Pressure – Maximum Weight	29.0 kPa	4.2 psi
Gradeability (maximum)	30 degrees	

### Service Refill Capacities

Cooling System	4.0 L	1.1 gal
Engine Oil	4.0 L	1.1 gal
Fuel Tank	45.0 L	11.9 gal
Hydraulic Tank	18.0 L	4.8 gal
Hydraulic System	35.0 L	9.2 gal

### Hydraulic System

Load Sensing Hydraulics with Variable Displacement Piston Pump		
Pump Flow @ 2,400 rpm	100 L/min	26 gal/min
Operating Pressure – Equipment	245 bar	3,553 psi
Operating Pressure – Travel	245 bar	3,553 psi
Operating Pressure – Swing	176 bar	2,553 psi
Auxiliary Circuit – Primary		
Flow*	65 L/min	17 gal/min
Pressure*	245 bar	3,553 psi
Auxiliary Circuit – Secondary		
Flow*	25 L/min	7.0 gal/min
Pressure*	245 bar	3,553 psi
Digging Force – Stick (standard)	13.8 kN	3,102 lbf
Digging Force – Stick (long)	12.3 kN	2,765 lbf
Digging Force – Bucket	23.3 kN	5,238 lbf

\*Flow and pressure are not combinable. Under load, as flow rises pressure goes down.

### Swing System

Machine Swing Speed	9.0 rpm
Boom Swing – Left	75 Degrees
Boom Swing – Right	50 Degrees

### Blade

Width	1570 mm	61.8 in
Height	320 mm	12.6 in

### Certification – Cab and Canopy

Roll Over Protective Structure (ROPS)	ISO 12117-2:2008
Tip Over Protective Structure (TOPS)	ISO 12117:1997
Top Guard	ISO 10262:1998 (Level I)

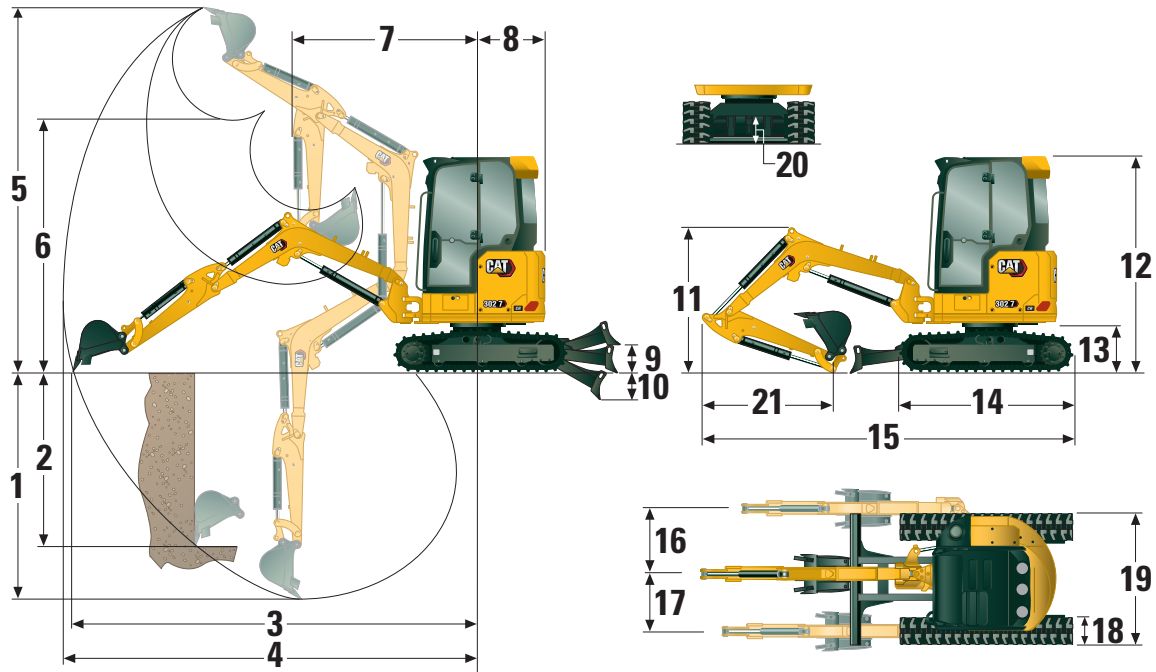

## Dimensions

	Standard Stick	Long Stick
1 Dig Depth	2510 mm (98.8 in)	2710 mm (106.7 in)
2 Vertical Wall	1870 mm (73.6 in)	2050 mm (80.7 in)
3 Maximum Reach at Ground Level	4510 mm (177.6 in)	4710 mm (185.4 in)
4 Maximum Reach	4660 mm (183.5 in)	4850 mm (190.9 in)
5 Maximum Dig Height	4270 mm (168.1 in)	4390 mm (172.8 in)
6 Maximum Dump Clearance	2950 mm (116.1 in)	3070 mm (120.9 in)
7 Boom in Reach	1710 mm (67.3 in)	1730 mm (68.1 in)
8 Tail Swing		
without Counterweight	775 mm (30.5 in)	775 mm (30.5 in)
with Counterweight (light)	845 mm (33.3 in)	845 mm (33.3 in)
with Counterweight (extra)	890 mm (35.0 in)	890 mm (35.0 in)
9 Maximum Blade Height	395 mm (15.6 in)	395 mm (15.6 in)
10 Maximum Blade Depth	515 mm (20.3 in)	515 mm (20.3 in)
11 Boom Height in Shipping Position	1560 mm (61.4 in)	1650 mm (65.0 in)
12 Overall Shipping Height	2480 mm (97.6 in)	2480 mm (97.6 in)
13 Swing Bearing Height	560 mm (22.0 in)	560 mm (22.0 in)
14 Overall Undercarriage Length	2010 mm (79.1 in)	2010 mm (79.1 in)
15 Overall Shipping Length†	4240 mm (166.9 in)	4280 mm (168.5 in)
16 Boom Swing Right	830 mm (32.7 in)	830 mm (32.7 in)
17 Boom Swing Left	605 mm (23.8 in)	605 mm (23.8 in)
18 Track Belt/Shoe Width	300 mm (11.8 in)	300 mm (11.8 in)
19 Track Width	1570 mm (61.8 in)	1570 mm (61.8 in)
20 Ground Clearance	310 mm (12.2 in)	310 mm (12.2 in)
21 Stick Length	1060 mm (41.7 in)	1260 mm (49.6 in)

†Overall Shipping Length depends on blade position during shipment.

# 302.7 CR Mini Excavator

## Cab

Lift Capacities – Minimum Configuration			Lift Point Radius – 2 m (6.6 ft)			Lift Point Radius – 3 m (9.8 ft)			Lift Point Radius (Maximum)				
			Over Front			Over Side	Over Front		Over Side	Over Front			m (ft)
			Blade Down	Blade Up	Blade Down		Blade Up	Blade Down		Blade Up	Over Side		
3 m (9.8 ft)	Standard Stick	kg (lb)				*777 (*1,713)	567 (1,250)	493 (1,087)	*470 (*1,036)	*470 (*1,036)	416 (917)	3.30 (10.8)	
	Long Stick	kg (lb)							*378 (*833)	*378 (*833)	368 (811)	3.54 (11.6)	
2 m (6.6 ft)	Standard Stick	kg (lb)				*886 (*1,953)	553 (1,219)	479 (1,056)	*426 (*939)	363 (800)	315 (694)	3.86 (12.7)	
	Long Stick	kg (lb)				*799 (*1,761)	553 (1,219)	479 (1,056)	*347 (*765)	331 (730)	287 (633)	4.06 (13.3)	
1 m (3.3 ft)	Standard Stick	kg (lb)				*1162 (*2,562)	517 (1,140)	445 (981)	*443 (*977)	330 (728)	286 (631)	4.03 (13.2)	
	Long Stick	kg (lb)				*1097 (*2,418)	515 (1,135)	443 (977)	*360 (*794)	303 (668)	262 (578)	4.22 (13.8)	
0 m (0 ft)	Standard Stick	kg (lb)	*1194 (*2,632)	928 (2,046)	767 (1,691)	*1299 (*2,864)	493 (1,087)	422 (930)	*525 (*1,157)	345 (761)	298 (657)	3.85 (12.6)	
	Long Stick	kg (lb)	*1190 (*2,623)	914 (2,015)	754 (1,662)	*1282 (*2,826)	486 (1,071)	415 (915)	*420 (*926)	313 (690)	270 (595)	4.05 (13.3)	

Minimum Weight includes cab, rubber tracks, no extra counterweight, operator, full fuel tank and blade.

Lift Capacities – Maximum Configuration			Lift Point Radius – 2 m (6.6 ft)			Lift Point Radius – 3 m (9.8 ft)			Lift Point Radius (Maximum)				
			Over Front			Over Side	Over Front		Over Side	Over Front			m (ft)
			Blade Down	Blade Up	Blade Down		Blade Up	Blade Down		Blade Up	Over Side		
3 m (9.8 ft)	Standard Stick	kg (lb)				*777 (*1,713)	734 (1,618)	595 (1,312)	*470 (*1,036)	*470 (*1,036)	*470 (*1,036)	3.30 (10.8)	
	Long Stick	kg (lb)							*378 (*833)	*378 (*833)	*378 (*833)	3.54 (11.6)	
2 m (6.6 ft)	Standard Stick	kg (lb)				*886 (*1,953)	719 (1,585)	581 (1,281)	*426 (*939)	*426 (*939)	392 (864)	3.86 (12.7)	
	Long Stick	kg (lb)				*799 (*1,761)	721 (1,590)	583 (1,285)	*347 (*765)	*347 (*765)	*347 (*765)	4.06 (13.3)	
1 m (3.3 ft)	Standard Stick	kg (lb)				*1162 (*2,562)	684 (1,508)	548 (1,208)	*443 (*977)	*443 (*977)	360 (794)	4.03 (13.2)	
	Long Stick	kg (lb)				*1097 (*2,418)	683 (1,506)	547 (1,206)	*360 (*794)	*360 (*794)	332 (732)	4.22 (13.8)	
0 m (0 ft)	Standard Stick	kg (lb)	*1194 (*2,632)	*1194 (*2,632)	939 (2,070)	*1299 (*2,864)	659 (1,453)	525 (1,157)	*525 (*1,157)	464 (1,023)	375 (827)	3.85 (12.6)	
	Long Stick	kg (lb)	*1190 (*2,623)	*1190 (*2,623)	928 (2,046)	*1282 (*2,826)	653 (1,440)	519 (1,144)	*420 (*926)	*420 (*926)	344 (758)	4.05 (13.3)	

Maximum Weight includes cab, steel tracks, extra counterweight, operator, full fuel tank and blade.

## Canopy

Lift Capacities – Minimum Configuration			Lift Point Radius – 2 m (6.6 ft)			Lift Point Radius – 3 m (9.8 ft)			Lift Point Radius (Maximum)				
			Over Front			Over Side	Over Front		Over Side	Over Front			m (ft)
			Blade Down	Blade Up	Blade Down		Blade Up	Blade Down		Blade Up	Over Side		
3 m (9.8 ft)	Standard Stick	kg (lb)				*777 (*1,713)	535 (1,179)	466 (1,027)	*470 (*1,036)	450 (992)	393 (866)	3.30 (10.8)	
	Long Stick	kg (lb)							*378 (*833)	*378 (*833)	348 (767)	3.54 (11.6)	
2 m (6.6 ft)	Standard Stick	kg (lb)				*886 (*1,953)	520 (1,146)	452 (996)	*426 (*939)	340 (750)	296 (653)	3.86 (12.7)	
	Long Stick	kg (lb)				*799 (*1,761)	523 (1,153)	455 (1,003)	*347 (*765)	311 (686)	270 (595)	4.06 (13.3)	
1 m (3.3 ft)	Standard Stick	kg (lb)				*1162 (*2,562)	485 (1,069)	418 (922)	*443 (*977)	308 (679)	268 (591)	4.03 (13.2)	
	Long Stick	kg (lb)				*1097 (*2,418)	485 (1,069)	418 (922)	*360 (*794)	284 (626)	246 (542)	4.22 (13.8)	
0 m (0 ft)	Standard Stick	kg (lb)	*1194 (*2,632)	868 (1,914)	719 (1,585)	*1299 (*2,864)	460 (1,014)	395 (871)	*525 (*1,157)	321 (708)	278 (613)	3.85 (12.6)	
	Long Stick	kg (lb)	*1190 (*2,623)	860 (1,896)	711 (1,567)	*1282 (*2,826)	456 (1,005)	390 (860)	*420 (*926)	293 (646)	253 (558)	4.05 (13.3)	

Minimum Weight includes canopy, rubber tracks, no extra counterweight, operator, full fuel tank and blade.

Lift Capacities – Maximum Configuration			Lift Point Radius – 2 m (6.6 ft)			Lift Point Radius – 3 m (9.8 ft)			Lift Point Radius (Maximum)				
			Over Front			Over Side	Over Front		Over Side	Over Front			m (ft)
			Blade Down	Blade Up	Blade Down		Blade Up	Blade Down		Blade Up	Over Side		
3 m (9.8 ft)	Standard Stick	kg (lb)				*777 (*1,713)	703 (1,550)	572 (1,261)	*470 (*1,036)	*470 (*1,036)	*470 (*1,036)	3.30 (10.8)	
	Long Stick	kg (lb)							*378 (*833)	*378 (*833)	*378 (*833)	3.54 (11.6)	
2 m (6.6 ft)	Standard Stick	kg (lb)				*886 (*1,953)	688 (1,517)	558 (1,230)	*426 (*939)	*426 (*939)	375 (827)	3.86 (12.7)	
	Long Stick	kg (lb)				*799 (*1,761)	690 (1,521)	559 (1,232)	*347 (*765)	*347 (*765)	344 (758)	4.06 (13.3)	
1 m (3.3 ft)	Standard Stick	kg (lb)				*1162 (*2,562)	653 (1,440)	524 (1,155)	*443 (*977)	423 (933)	343 (756)	4.03 (13.2)	
	Long Stick	kg (lb)				*1097 (*2,418)	652 (1,437)	523 (1,153)	*360 (*794)	*360 (*794)	316 (697)	4.22 (13.8)	
0 m (0 ft)	Standard Stick	kg (lb)	*1194 (*2,632)	1177 (2,595)	897 (1,978)	*1299 (*2,864)	628 (1,385)	501 (1,105)	*525 (*1,157)	442 (974)	357 (787)	3.85 (12.6)	
	Long Stick	kg (lb)	*1190 (*2,623)	1166 (2,571)	887 (1,955)	*1282 (*2,826)	622 (1,371)	495 (1,091)	*420 (*926)	406 (895)	327 (721)	4.05 (13.3)	

Maximum Weight includes canopy, steel tracks, extra counterweight, operator, full fuel tank and blade.

\*The above loads are in compliance with hydraulic excavator lift capacity rating standard ISO 10567:2007 and they do not exceed 87% of hydraulic lifting capacity or 75% of tipping capacity. The excavator bucket weight is not included on this chart. Lifting capacities are for standard stick.

## Standard and Optional Equipment

Standard and optional equipment may vary. Consult your Cat dealer for details.

	Standard	Optional		Standard	Optional
<b>ENGINE</b>			<b>OPERATOR ENVIRONMENT (continued)</b>		
Cat® C1.1 Turbo Engine (U.S. EPA Tier 4 Final/ EU Stage V)	✓		Retractable High Visibility Seat Belt (75 mm/3 in)	✓	
Automatic Engine Idle	✓		Seat Belt Reminder System		✓
Automatic Engine Shutdown	✓		Coat Hook	✓	
Automatic Two Speed Travel	✓		Cup Holder	✓	
Fuel Water Separator	✓		Storage Pocket	✓	
Power on Demand (not available in all regions)	✓		Skylight	✓	
Variable Displacement Piston Pump	✓		Mounting Bosses for Front	✓	
Load Sensing/Flow Sharing Hydraulics	✓		Signaling/Warning Horn	✓	
<b>HYDRAULICS</b>			Interior Light (Cab only)	✓	
Smart Tech Electronic Pump	✓		Boom Light, Halogen (not available in all regions)	✓	
Accumulator	✓		LED Front Lights		✓
Automatic Swing Brake	✓		LED Front and Rear Lights		✓
Auxiliary Hydraulic Lines	✓		LED Boom Light		✓
One and Two Way Auxiliary Flow	✓		Utility Space for Mobile Phone	✓	
Continuous Auxiliary Flow	✓		Cab Mirrors Left and Right (vary by region)	✓	
Auxiliary Line Quick Disconnects	✓		Radio – Bluetooth®, Auxiliary, Microphone, USB (charging only) (Cab only)		✓
<b>OPERATOR ENVIRONMENT</b>			Next Generation Color LCD Monitor (IP66)	✓	
Tilt-up Canopy or Tilt-Up Cab	✓		– Fuel Level and Coolant Temperature Gauges	✓	
Cab with Air Conditioning		✓	– Maintenance and Machine Monitoring	✓	
Cab with Heater		✓	– Performance and Machine Adjustments	✓	
Top Guard ISO 10262:1998 Level I	✓		– Numeric Security Code	✓	
ROPS – ISO 12117-2:2008	✓		– Multiple Languages	✓	
TOPS – ISO 12117:1997	✓		– Hour Meter with Wake Up Switch	✓	
Stick Steer Mode	✓		– Jog Dial (Cab only)	✓	
Travel Cruise Control	✓		Next Generation Advanced Monitor		✓
Control Pattern Changer (optional in some regions)	✓		– Touchscreen		✓
Adjustable Wrist Rests	✓		– Site Reference System		✓
Washable Floor Mat	✓		– High Definition Camera Capable (IP68 and IP69K)		✓
Travel Pedals and Hand Levers	✓		– Numeric Security Code		✓
No Travel Pedals and Hand Levers (optional in some regions)		✓			
Machine Security	✓				
Standard Key with Pass Code	✓				
Push to Start with Key Fob/Pass Code		✓			
Fabric Suspension Seat (Cab only)	✓				
Vinyl Suspension Seat (Canopy only)	✓				
Vinyl Non-Suspension Seat (Canopy only) (not available in all regions)		✓			
Hydraulic Lockout – All Controls	✓				

# 302.7 CR Mini Excavator

## Standard and Optional Equipment

Standard and optional equipment may vary. Consult your Cat dealer for details.

	Standard	Optional		Standard	Optional
<b>UNDERCARRIAGE</b>			<b>ELECTRICAL</b>		
Rubber Belt (300 mm/11.8 in wide)	✓		12 Volt Battery	✓	
Steel Track (300 mm/11.8 in wide)		✓	Software (machine and monitor)	✓	
Dozer Blade	✓		Maintenance Free Battery	✓	
Dozer Blade Float	✓		Lock Out/Tag Out Battery Disconnect	✓	
Tie Downs on Track Frame	✓		Signaling/Warning Horn	✓	
<b>BOOM, STICK AND LINKAGES</b>			12 Volt Power Socket	✓	
One Piece Boom (2085 mm/82.1 in)	✓		Product Link PL243 (regulations apply)		✓
Standard Stick (1060 mm/41.7 in)	✓		Product Link PLE643 (regulations apply)		✓
Long Stick (1260 mm/49.6 in)		✓	Travel Alarm (standard in some regions)		✓
Front Shovel Capable	✓		<b>GUARDING</b>		
Pin-On	✓		Polycarbonate Half Height Front Guard (Canopy only)		✓
Dual Lock Manual Coupler		✓	Polycarbonate Front Guard (ISO 10262 1998 Level I and EN356 P5A)		✓
Thumb Ready (not available in all regions)	✓		<b>OTHER</b>		
Boom Lowering Control Valve (Europe only)	✓		Bio Oil Capable		✓
Stick Lowering Control Valve (Europe only)	✓		Eco Drain		✓
Certified Lifting Eye (optional in some regions)	✓		Water Jacket Heater		✓
Attachments including Couplers, Thumbs, Buckets, Augers and Hammers		✓	Light Counterweight (100 kg/221 lb)		✓
2nd Auxiliary Hydraulic Lines		✓	Extra Counterweight (250 kg/551 lb)		✓
Bucket Divert Lines		✓			
Boom Lowering Check Valve		✓			
Stick Lowering Check Valve		✓			
Hydraulic Quick Coupler Lines (not available in all regions)		✓			

# 302.7 CR (Fixed Undercarriage) Environment Declaration

The following information applies to the machine at the time of final manufacture as configured for sale in the regions covered in this document. The content of this declaration is valid as of the date issued; however, content related to machine features and specifications are subject to change without notice. For additional information, please see the machine's Operation and Maintenance Manual.

For more information on sustainability in action and our progress, please visit <https://www.caterpillar.com/en/company/sustainability>.

## Engine

- The Cat® C1.1 engine meets U.S. EPA Tier 4 Final and EU Stage V emission standards.
- Cat diesel engines are required to use ULSD (ultra-low sulfur diesel fuel with 15 ppm of sulfur or less) or ULSD blended with the following lower-carbon intensity fuels\*\* up to:
  - ✓ 20% biodiesel FAME (fatty acid methyl ester)
  - ✓ 100% renewable diesel, HVO (hydrotreated vegetable oil) and GTL (gas-to-liquid) fuels

Refer to guidelines for successful application. Please consult your Cat dealer or "Caterpillar Machine Fluids Recommendations" (SEBU6250) for details.

*\*Engines with no aftertreatment devices can use higher blends, up to 100% biodiesel (for use of blends higher than 20% biodiesel, consult your Cat dealer).*

*\*\*Tailpipe greenhouse gas emissions from lower-carbon intensity fuels are essentially the same as traditional fuels.*

## Air Conditioning

- The air conditioning system on this machine contains the fluorinated greenhouse gas refrigerant R134a (Global Warming Potential = 1430). The system contains 1.0 kg of refrigerant which has a CO<sub>2</sub> equivalent of 1.430 metric tonnes.

## Paint

- Based on best available knowledge, the maximum allowable concentration, measured in parts per million (PPM), of the following heavy metals in paint are:
  - Barium < 0.01%
  - Cadmium < 0.01%
  - Chromium < 0.01%
  - Lead < 0.01%

## Sound Performance

Operator Sound Pressure\* 78 dB(A) (ISO 6396:2008)

Exterior Sound Power Level\*\* 94 dB(A) (ISO 6395:2008)

\*The declared dynamic operator sound pressure levels per ISO 6396:2008. The measurements were conducted with the cab doors and windows closed.

\*\*The labeled sound power level for the CE marked configurations when measured according to the test procedure and conditions specified in 2000/14/EC.

## Oils and Fluids

- Caterpillar factory fills with ethylene glycol coolants. Cat Diesel Engine Antifreeze/Coolant (DEAC) and Cat Extended Life Coolant (ELC) can be recycled. Consult your Cat dealer for more information.
- Cat Bio HYDO™ Advanced is an EU Ecolabel approved biodegradable hydraulic oil.
- Additional fluids are likely to be present, please consult the Operations and Maintenance Manual or the Application and Installation guide for complete fluid recommendations and maintenance intervals.

## Features and Technology

- The following features and technology may contribute to fuel savings and/or carbon reduction. Features may vary. Consult your Cat dealer for details.
  - Advanced hydraulic systems balance power and efficiency
  - Power On Demand provides full time efficiency and power when you need it and is transparent to the operator
  - Auto idle and auto engine shutdown
  - Extended maintenance intervals reduce fluid and filter consumption
  - Remote Flash and Remote Troubleshoot (if equipped)

## Recycling

- The materials included in machines are categorized as below with approximate weight percentage. Because of variations of product configurations, the following values in the table may vary.

Material Type	Weight Percentage
Steel	65.26%
Iron	13.07%
Rubber	8.59%
Other	3.04%
Nonferrous Metal	2.93%
Plastic	2.67%
Fluid	2.35%
Uncategorized	0.85%
Mixed-Metal and Nonmetal	0.68%
Mixed-Metal	0.54%
Mixed-Nonmetallic	0.02%
Total	100%

- A machine with higher recyclability rate will ensure more efficient usage of valuable natural resources and enhance End-of-Life value of the product. According to ISO 16714:2008 (Earth-moving machinery – Recyclability and recoverability – Terminology and calculation method), recyclability rate is defined as percentage by mass (mass fraction in percent) of the new machine potentially able to be recycled, reused or both.

All parts in the bill of material are first evaluated by component type based on a list of components defined by the ISO 16714:2008 and Japan CEMA (Construction Equipment Manufacturers Association) standards. Remaining parts are further evaluated for recyclability based on material type.

Because of variations of product configurations, the following values in the table may vary.

Recyclability – 95%

- The data provided above was based on the product configuration as provided by the individual product group.

# 302.7 CR Mini Excavator

---

For more complete information on Cat products, dealer services, and industry solutions, visit us on the web at [www.cat.com](http://www.cat.com)

© 2024 Caterpillar  
All rights reserved

Materials and specifications are subject to change without notice. Featured machines in photos may include additional equipment. See your Cat dealer for available options.

CAT, CATERPILLAR, LET'S DO THE WORK, their respective logos, "Caterpillar Corporate Yellow," the "Power Edge" and Cat "Modern Hex" trade dress as well as corporate and product identity used herein, are trademarks of Caterpillar and may not be used without permission.

AEHQ8349-05 (07-2024)  
Replaces AEHQ8349-04  
Build Number: 07A  
(Global excluding  
China and Japan)

