

Cat[®] TL1255

TELEHANDLER



Specifications

Engine

Model*	Cat [®] C3.6L	
Gross Power (Basic)	100 kW	134 hp

*Meets U.S. EPA Tier 4 Final emission standards.

Operating Specifications

Maximum Rated Load Capacity	5443 kg	12,000 lb
Maximum Lift Height (o/r Down)	16.7 m	54.9 ft
Maximum Forward Reach	12.8 m	42 ft
Frame Leveling	10°	
Top Travel Speed	33.8 km/h	21 mph
Capacity at Maximum Height (o/r Down)	2268 kg	5,000 lb
Capacity at Maximum Reach (o/r Down)	1587 kg	3,500 lb
Turning Radius over Tires	4.3 m	14.1 ft
Drawbar Pull – Loaded	117.9 kN	26,510 lb
Operating Weight	15 505 kg	34,182 lb

Hydraulic System

Variable displacement load sensing axial piston pump		
Auxiliary Hydraulic Pressure	228 bar	3,307 psi
Auxiliary Hydraulic Flow	95 L/min	25 gal/min

Service Refill Capacities

Fuel Tank	145 L	38 gal
Diesel Exhaust Fluid (DEF) Tank	21.5 L	5.7 gal
Hydraulic System	189 L	50 gal

Axles and Brakes

- Trunnion mounted planetary 55-degree steer axles
- High bias limited slip differential on front axle
- Service Brakes: Inboard wet disc brakes on front and rear axles
- Parking Brakes: Wet disc, spring applied hydraulic release on front axle

Transmission Speeds

Forward/Reverse	4 Speeds/3 Speeds
-----------------	-------------------

Tires

Standard	400/75-28 Duraforce Air
Optional	400/75-28 Duraforce Foam 360/85-28 Telemaster Solid 17.5 × 25 16PR Air 17.5 × 25 12PR Foam 400/75-28 Non-Marking Air 400/75-28 Non-Marking Foam

Boom Performance

Boom Up/Boom Down	17.0 Seconds/14.4 Seconds
Tele In/Tele Out	15.3 Seconds/19.7 Seconds

Optional Work Tool Attachments

Hydraulic IT Coupler

Carriages

Standard Tilt	1270 mm	50 in
	1524 mm	60 in
	1829 mm	72 in
Side Tilt	1270 mm	50 in
	1829 mm	72 in
Side Shift	1220 mm	48 in
	1829 mm	72 in
Dual Hydraulic Fork Positioner	1270 mm	50 in
	1829 mm	72 in

Forks

Pallet	1220 mm	48 in
	1525 mm	60 in
	1829 mm	72 in
Block/Cubing	1220 mm	48 in
Fork Extensions*	2286 mm	90 in

Buckets

General Purpose	1.0 m ³	1.3 yd ³
	1.5 m ³	2.0 yd ³
Multi Purpose Grapple	1.0 m ³	1.3 yd ³
	1.3 m ³	1.7 yd ³

Material

Handling Arm	Adjustable 2-4 m	Adjustable 6.7-13.2 ft
Truss Booms	3.7 m	12 ft
	4.6 m	15 ft
Truss with Winch	0.9 m	3 ft
	3.7 m	12 ft

Fork Mounted

Work Platform	1220 mm × 2438 mm	4 ft × 8 ft
Truss Boom	Adjustable 2.1-3.6 m	Adjustable 7-12 ft
Lifting Hook		
Trash Hopper		

*For use with 1525 mm (60 in) forks or larger



TL1255 Telehandler

Dimensions (All dimensions are approximate.)

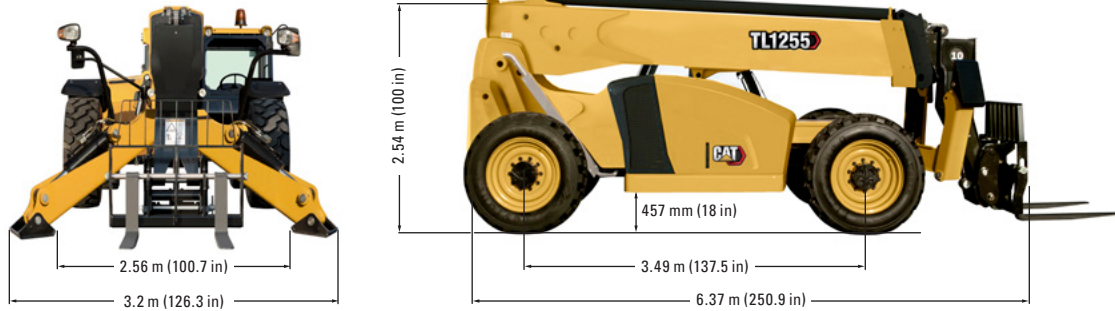

Load Chart and Dimensions

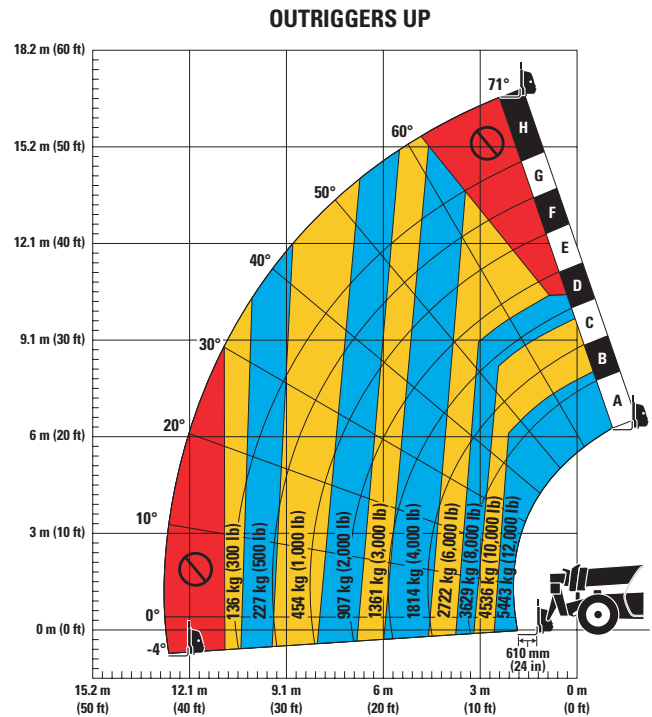
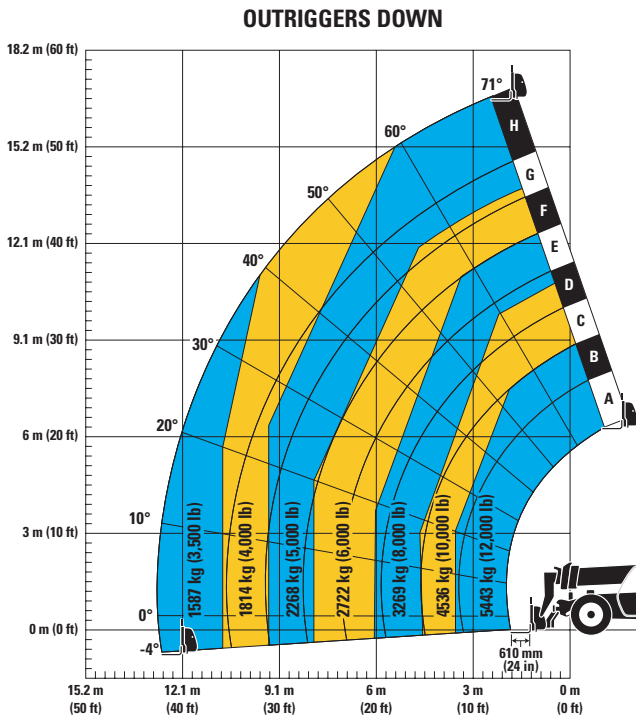

IMPORTANT

Rated lift capacities shown are with machine equipped with carriage and pallet forks. The machine must be level on a firm surface with undamaged, properly inflated tires. Machine specifications and stability are based on rated lift capacities at specific boom angles and boom lengths. (If specifications are critical, the proposed application should be discussed with your dealer.)

DO NOT exceed rated lift capacity loads, as unstable and dangerous machine conditions will result.

DO NOT tip the machine forward to determine the allowable load.

Use only approved attachments with proper material handler model/attachment load capacity charts displayed in the operator's cab.

Due to continuous product improvements, machine specifications and/or equipment changes may be made without prior notification. This machine meets or exceeds ANSI/ITSDF B56.6-2016 as originally manufactured for intended applications.

For more complete information on Cat products, dealer services, and industry solutions, visit us on the web at www.cat.com

© 2021 Caterpillar
All rights reserved

Materials and specifications are subject to change without notice. Featured machines in photos may include additional equipment. See your Cat dealer for available options.

CAT, CATERPILLAR, LET'S DO THE WORK, their respective logos, "Caterpillar Corporate Yellow," the "Power Edge" and Cat "Modern Hex" trade dress as well as corporate and product identity used herein, are trademarks of Caterpillar and may not be used without permission.

AEHQ8364 (03-2021)
(N Am)

