

Image is a representation only,  
and may not show optional  
attachments.

### SPECIFICATIONS

#### I-6, 4-Stroke-Cycle-Diesel

Emissions	..... EPA Tier II and IMO Compliant
Displacement	..... 12 L (732 cu. in.)
Rated Engine Speed	..... 2300
Bore	..... 130.0 mm (5.1 in.)
Stroke	..... 150.0 mm (5.9 in.)
Aspiration	..... Turbocharged-Aftercooled
Governor	..... Electronic
Cooling System	..... Heat Exchanger
Weight, Net Dry (approx)	..... 1,174 kg (2,588 lb)
Refill Capacity	
Cooling System	..... 45 L (12.0 U.S. gal)
Lube Oil System	..... 28 L (7.5 U.S. gal)
Oil Change Interval	..... 250 hrs
Caterpillar Diesel Engine Oil 10W30 or 15W40	
Center Sump Oil Pan	
Rotation (from flywheel end)	..... Counterclockwise
Flywheel and Flywheel Housing	..... SAE No. 1
Flywheel Teeth	..... 113

### STANDARD ENGINE EQUIPMENT

#### Air Inlet System

Corrosion resistant sea water aftercooler, air cleaner/fumes disposal (closed system), jacket water cooled turbocharger

#### Control System

Electronic governing, cold mode start strategy, power compensation for fuel temperature, programmable low idle, electronic diagnostics and fault logging, engine and transmission monitoring (speed, temperature, pressure), fuel/air ratio control

#### Cooling System

Thermostat and housing, gear-driven jacket water pump, self-priming, gear-driven sea water pump with rubber impeller, integral heat exchanger/expansion tank with removable tube bundle and replaceable copper-nickel tubes

#### Exhaust System

Watercooled exhaust manifold and turbocharger

#### Flywheels & Flywheel Housings

SAE No. 1 flywheel, 113 teeth, SAE No. 1 flywheel housing (10 degree slant pad), SAE standard rotation

#### Fuel System

Fuel filter, RH service on port, LH service on starboard, fuel transfer pump, fuel priming pump, flexible fuel lines

#### Instrumentation

Electric service meter

#### Lube System

Crankcase breather, oil cooler, spin-on oil filter, RH service on port, LH service on starboard, center sump oil pan, oil filler, dipstick, RH service on port, LH service on starboard, gear-driven oil pump

#### Mounting System

Front support

#### Power Take-Offs

Hydraulic pump drive, SAE A, 11 tooth spline, 57 ft-lbs max torque, counterclockwise as viewed from rear of the engine looking into the pump drive and turns 1.41 x engine speed, 345 mm crankshaft pulley, 15.88 mm width single groove

#### Protection System

12 or 24 volt electronic shutdown (energized-to-run)

#### General

Vibration damper, lifting eyes, RH or LH service options, literature, variable engine wiring, upper rear-facing customer wiring connector and ECAP connection, electronic installation kit (connectors, pins, sockets)

#### ISO Certification

Factory-designed systems built at Caterpillar ISO9001:2000 certified facilities

## MARINE ENGINE PERFORMANCE

Preliminary

**C12 DITA ACERT**  
**492 bkW (660 bhp) @ 2300 rpm**  
**E Rating (High Performance) — DM7530-01**

EPA Tier II and IMO Compliant

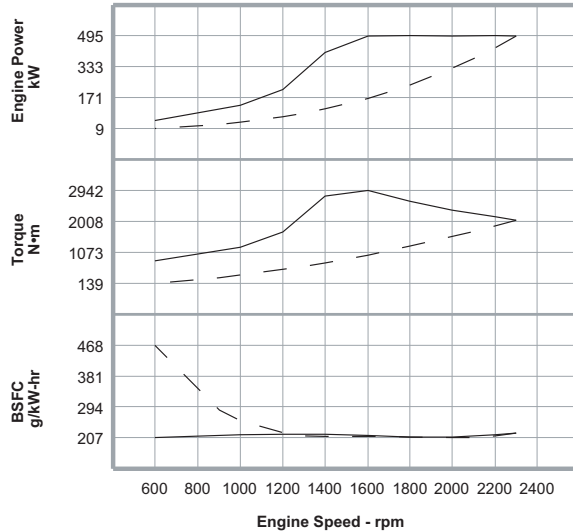

**Metric**      **Maximum Power** **Prop Demand**      **492 kW**

### Preliminary Performance Data

	Engine Speed rpm	Engine Power kW	Engine Torque N·m	BSFC g/kW-hr	Fuel Rate L/hr
<b>Maximum Power Data</b>	2300	492.0	2043	220.0	129.0
	2200	494.9	2148	214.1	126.3
	2000	492.7	2353	208.0	122.2
	1800	493.8	2620	208.9	123.0
	1600	493.0	2942	212.6	124.9
	1400	406.3	2771	216.1	104.7
	1200	210.4	1675	216.3	54.3
	1000	128.2	1225	214.5	32.8
	600	50.9	810	206.9	12.5
	<b>Prop Demand Data</b>	2300	492.0	2043	220.0
2200		430.6	1869	211.2	108.4
2100		374.5	1703	207.0	92.4
2000		323.5	1545	206.6	79.7
1800		235.8	1251	209.1	58.8
1600		165.6	989	210.7	41.6
1400		111.0	757	210.1	27.8
1300		88.8	653	212.2	22.5
1200		69.9	556	220.8	18.4
900		29.5	313	283.8	10.0
600	8.7	139	468.5	4.9	

Cubic prop demand curve with 3.0 exponent for displacement hulls only.

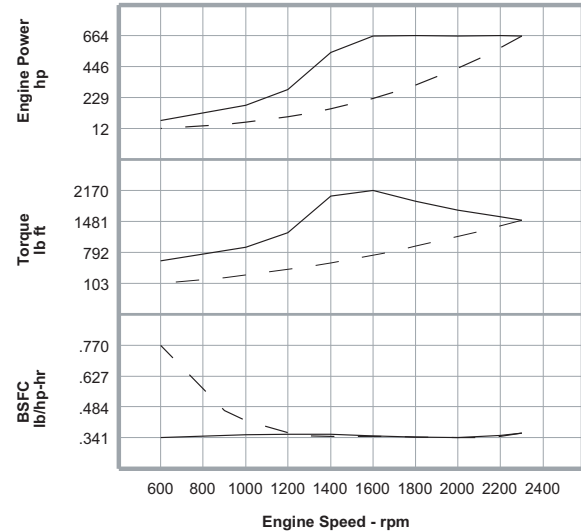

**English**      **Maximum Power** **Prop Demand**      **660 hp**

### Preliminary Performance Data

	Engine Speed rpm	Engine Power hp	Engine Torque lb ft	BSFC lb/hp-hr	Fuel Rate gph
<b>Maximum Power Data</b>	2300	659.8	1507	.362	34.1
	2200	663.7	1584	.352	33.4
	2000	660.7	1735	.342	32.3
	1800	662.2	1932	.343	32.5
	1600	661.1	2170	.350	33.0
	1400	544.9	2044	.355	27.7
	1200	282.2	1235	.356	14.3
	1000	171.9	903	.353	8.7
	600	68.3	597	.340	3.3
	<b>Prop Demand Data</b>	2300	659.8	1507	.362
2200		577.4	1378	.347	28.6
2100		502.2	1256	.340	24.4
2000		433.8	1139	.340	21.1
1800		316.2	923	.344	15.5
1600		222.1	729	.346	11.0
1400		148.9	558	.345	7.3
1300		119.1	482	.349	5.9
1200		93.7	410	.363	4.9
900		39.6	231	.467	2.6
600	11.7	103	.770	1.3	

Power produced at the flywheel will be within standard tolerances up to 50°C (122°F) combustion air temperature measured at the air cleaner inlet, and fuel temperature up to 52°C (125°F) measured at the fuel filter base. Power rated in accordance with NMMA procedure as crankshaft power. Reduce crankshaft power by 3% for propeller shaft power.

### DIMENSIONS

Preliminary

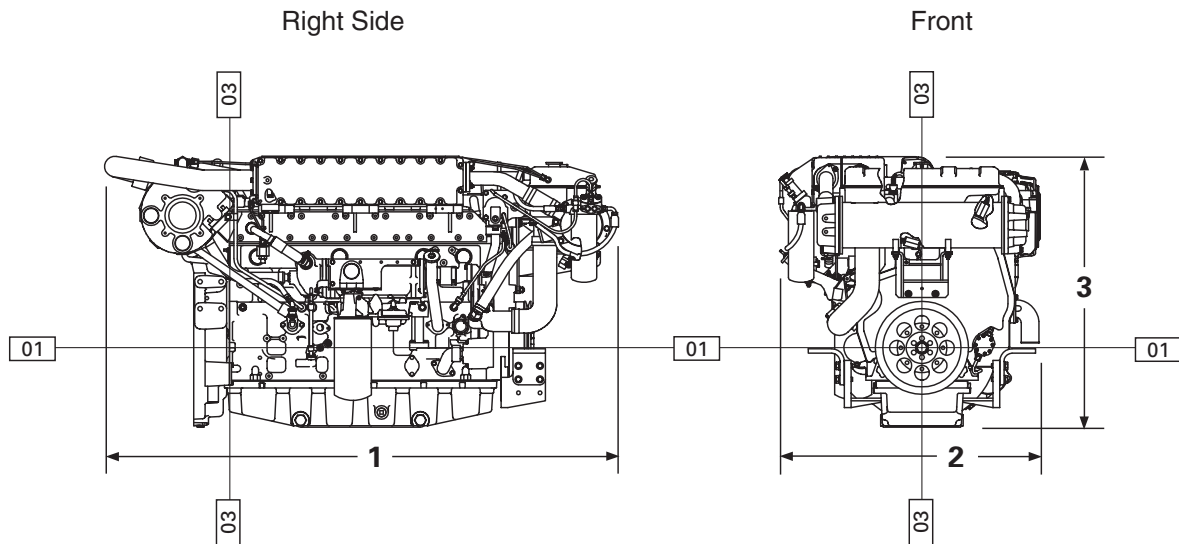

Preliminary Engine Dimensions		
(1) Length to Flywheel Housing	1573.9 mm	61.96 in
(2) Width	968.6 mm	38.13 in
(3) Height	1008.7 mm	39.71 in
Weight, Net Dry (approx)	1174 kg	2,588 lb

Note: Do not use for installation design.

**RATING DEFINITIONS AND CONDITIONS**

---

**E Rating (High Performance)**

% Load Factor: up to 30

% Time at Rated RPM: up to 8

Typical Time at Full Load: 1/2 hours out of 6

Typical Hour/Year: 250 to 1000

Typical Applications: For vessels operating at rated load and rated speed up to 8% of the time (up to 30% load factor). Typical applications could include but are not limited to vessels such as pleasure craft, harbor patrol boats, harbor master boats, some fishing or patrol boats. Typical operation ranges from 250 to 1000 hours per year.

**Power** at declared engine speed is in accordance with ISO3046-1:2002E. Caterpillar maintains ISO9001:1994/QS-9000 approved engine test facilities to assure accurate calibration of test equipment. Electronically controlled engines are set at the factory at the advertised power corrected to standard ambient conditions. The published fuel consumption rates are in accordance with ISO3046-1.

**Fuel rates** are based on fuel oil of 35° API [16°C (60°F)] gravity having an LHV of 42 780 kJ/kg (18,390 Btu/lb) when used at 29°C (85°F) and weighing 838.9 g/L (7.001 lb/U.S. gal). Additional ratings may be available for specific customer requirements. Consult your Caterpillar representative for additional information.

Performance data is calculated in accordance with tolerances and conditions stated in this specification sheet and is only intended for purposes of comparison with other manufacturers' engines. Actual engine performance may vary according to the particular application of the engine and operating conditions beyond Caterpillar's control.

Power produced at the flywheel will be within standard tolerances up to 50°C (122°F) combustion air temperature measured at the air cleaner inlet, and fuel temperature up to 52°C (125°F) measured at the fuel filter base. Power rated in accordance with NMMA procedure as crankshaft power. Reduce crankshaft power by 3% for propeller shaft power.

CAT, CATERPILLAR, ACERT, their respective logos and "Caterpillar Yellow," as well as corporate and product identity used herein, are trademarks of Caterpillar and may not be used without permission.