

3516C



MARINE PROPULSION ENGINE

| | | |
|----------|------------|----------|
| 2161 mhp | (2131 bhp) | 1590 bkW |
| 2270 mhp | (2239 bhp) | 1670 bkW |
| 2379 mhp | (2346 bhp) | 1750 bkW |



Image shown may not reflect actual engine

COMPLETE SOLUTIONS FOR YOUR MARINE APPLICATION

- Single-source for support and service
- Industry-leading warranty coverage for factory packaged components
- Global dealer network for service in any location

EFFICIENT OPERATION

- Instrument panel with cold mode start strategy and programmable low idle
- Electronic governing control unit minimizes fuel consumption and monitors engine operating parameters
- Optional alarm and protection system

IMPROVED PERFORMANCE AND FUNCTION

- Advanced combustion design uses the optimum configurations and cylinder geometry
- Enhanced control of fuel injection optimized through crank timing

ENVIRONMENTALLY CONSCIOUS

- Closed crankcase ventilation system and redesigned piston for improved efficiency and lower emissions
- Optimal nozzle geometry and electronic injection control for improved fuel delivery
- EPA Marine Tier 3/IMO Tier II Emissions Compliant

SPECIFICATIONS

V-16, 4-Stroke-Cycle-Diesel

- EPA Marine Tier 3 compliant
- IMO Tier II emissions compliant
- 78.08 L (4765 in³) displacement
- 1600 rpm
- 170 mm (6.69 in) bore x 215 mm (8.46 in) stroke
- Turbocharged-aftercooled aspiration
- Electronically governed A4 ECU
- Heat exchanger or keel cooled
- Refill capacity
 - Lube oil system: 779.8 L (206 gal)
- 1000-hour oil change interval
- Counterclockwise rotation
- SAE No. 00 flywheel and flywheel housing (183 teeth)
- Engine diagnostic system data link messaging

All new 3500C marine EPA Tier 3 capable engines, including both propulsion and auxiliary units, will be required to use a maximum concentration of 20% glycol mixture in the aftercooler circuit. This restriction applies equally to both heat exchanger cooled and keel cooled configurations (box coolers). In the event that specific project needs require higher levels of freeze protection, (lower freeze temperature), please contact ASC to review the specific engine rating and glycol concentration desired.

The jacket water circuit will continue to be capable of operation up to 50% glycol.

DIMENSIONS

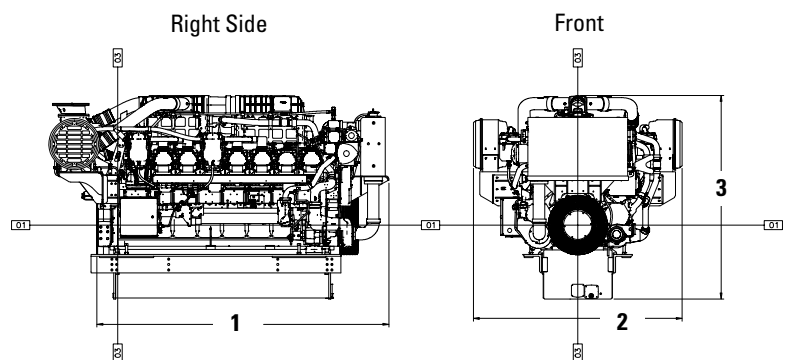

ENGINE DIMENSIONS & WEIGHT

| | | |
|---------------------------------------|-----------|-----------|
| (1) Length to Flywheel Housing | 3191.8 mm | 125.7 in |
| (2) Width | 2283.8 mm | 89.9 in |
| (3) Height | 2224.5 mm | 87.6 in |
| Weight, Net Dry (approx) | 9600 kg | 21,164 lb |

Note: Do not use these dimensions for installation design. See general dimension drawings for detail (Drawing #420-1880). For complete information, please refer to the Marine Spec Sheet Wizard.

MARINE ENGINE PERFORMANCE

| rpm | A Rating | | | | B Rating | | | | C Rating | | | |
|------|----------|-------|------|----------|----------|-------|------|----------|----------|-------|------|----------|
| | bhp | g/hr | bkW | g/bkW-hr | bhp | g/hr | bkW | g/bkW-hr | bhp | g/hr | bkW | g/bkW-hr |
| 1600 | 2132 | 103.6 | 1590 | 207.0 | 2240 | 108.9 | 1670 | 207.0 | 2347 | 114.1 | 1750 | 207.0 |
| 1300 | 2132 | 100.8 | 1590 | 201.3 | 2240 | 105.7 | 1670 | 201.0 | 2347 | 110.8 | 1750 | 201.0 |
| 1100 | 1958 | 89.8 | 1460 | 195.3 | 2012 | 92.2 | 1500 | 195.3 | 2119 | 97.2 | 1580 | 195.3 |
| 900 | 1021 | 50.0 | 761 | 208.7 | 1021 | 50.0 | 761 | 208.7 | 1021 | 50.0 | 761 | 208.7 |
| 700 | 528 | 26.9 | 394 | 216.6 | 528 | 26.9 | 394 | 216.6 | 528 | 26.9 | 394 | 216.6 |
| 650 | 471 | 24.1 | 351 | 218.0 | 471 | 24.1 | 351 | 218.0 | 471 | 24.1 | 351 | 218.0 |

| rpm | A Rating | | | | B Rating | | | | C Rating | | | |
|------|----------|-------|------|----------|----------|-------|------|----------|----------|-------|------|----------|
| | bhp | g/hr | bkW | g/bkW-hr | bhp | g/hr | bkW | g/bkW-hr | bhp | g/hr | bkW | g/bkW-hr |
| 1600 | 2132 | 103.6 | 1590 | 207.0 | 2240 | 108.9 | 1670 | 207.0 | 2347 | 114.1 | 1750 | 207.0 |
| 1300 | 1144 | 56.6 | 853 | 210.8 | 1202 | 59.5 | 896 | 210.9 | 1259 | 62.4 | 939 | 211.0 |
| 1100 | 693 | 34.2 | 517 | 210.4 | 728 | 35.8 | 543 | 209.4 | 763 | 37.3 | 569 | 208.5 |
| 900 | 379 | 19.3 | 283 | 216.6 | 398 | 20.2 | 297 | 215.5 | 418 | 21.0 | 311 | 214.5 |
| 700 | 179 | 9.7 | 133 | 231.4 | 188 | 10.1 | 140 | 229.4 | 197 | 10.5 | 147 | 227.5 |
| 650 | 143 | 8.0 | 107 | 238.3 | 150 | 8.3 | 112 | 236.0 | 157 | 8.6 | 117 | 233.9 |

STANDARD ENGINE EQUIPMENT

- Corrosion-resistant aftercooler core
- Dual A4 engine control modules w/electronic unit injector fuel system
- Dual turbochargers with water-cooled bearings and heat shields
- Vibration damper and guard
- Closed crankcase ventilation system
- Thermostats and housing
- Electronically cooled unit injectors
- Engine oil cooler and oil filler
- Auxiliary fresh water pump
- Gear-driven, centrifugal jacket water pump
- Oil filter, oil level gauge, and oil pump

OPTIONAL ATTACHMENTS

- Plate-type heat exchanger
- Special appearance packages with chrome cover
- Marine society certifications
- Power takeoff
- Shutoff and alarm contactors
- SOLAS compliant fuel connections with spill shield
- Instrument panel with color Marine Power Display (MPD)
- Mounting rails
- Sea water pump
- See Marine Price List for additional attachments

RATING DEFINITIONS AND CONDITIONS

A Rating (Unrestricted Continuous)

Typical applications: For vessels operating at rated load and rated speed up to 100% of the time without interruption or load cycling (80% to 100% load factor). Typical applications could include but are not limited to vessels such as freighters, tugboats, bottom trawlers, or deep river tugboats. Typical operation ranges from 5000 to 8000 hours per year.

B Rating (Heavy Duty)

Typical applications: For vessels operating at rated load and rated speed up to 80% of the time, or 10 hours out of 12, with some load cycling (40% to 80% load factor). Typical applications could

include but are not limited to vessels such as mid-water trawlers, purse seiner, crew and supply boats, ferries, or towboats. Typical operation ranges from 3000 to 5000 hours per year.

C Rating (Maximum Continuous)

Typical applications: For vessels operating at rated load and rated speed up to 50% of the time, or 6 hours out of 12, with cyclical load and speed (20% to 80% load factor). Typical applications could include but are not limited to vessels such as ferries, harbor tugs, fishing boats, offshore service boats, displacement hull yachts, or short trip coastal freighters. Typical operation ranges from 2000 to 4000 hours per year.

CAT, CATERPILLAR, their respective logos, "Caterpillar Yellow" and the "Power Edge" trade dress, as well as corporate and product identity used herein, are trademarks of Caterpillar and may not be used without permission.