

1106A-70TG/TAG Electric Power Engines

Power range 1500 rpm 127-202 kW (engine gross power)

Power range 1800 rpm 146-206 kW (engine gross power)

Emissions

Fuel Optimised

Building upon Perkins proven reputation within the power generation industry, the 1106A Series range of Electropak engines now fit even closer to customers' needs.

In the world of power generation success is only gained by providing more for less. With the 1106A products, Perkins has engineered even higher levels of reliability, yet lowered the cost of ownership.

1100A engines are designed for territories that do not require compliance to EPA or EU emissions legislation. These engines are assembled around optimal, efficient manufacturing processes with state-of-the-art technology. They are built to provide the right power solution for customers who sell their applications into lesser regulated countries.

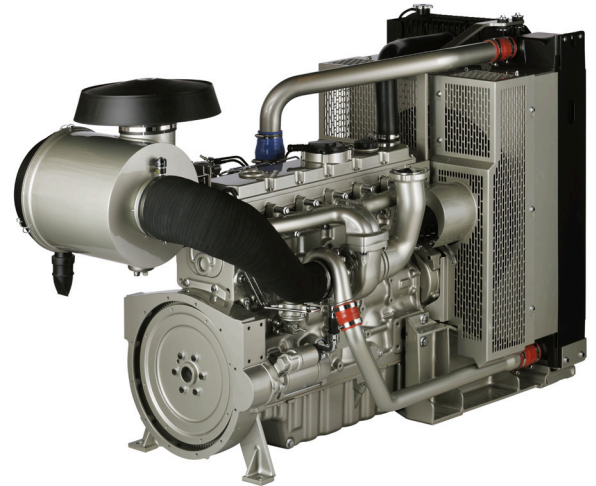

Features and benefits

- The Perkins® 1106A engines provide **greater productivity** through an improved power to weight ratio and have been designed for excellent load acceptance so your facility is powered quickly in all conditions.

The 1106A has been designed for excellent load acceptance so your facility is powered quickly at all conditions.

- The 1106A power density has been achieved in a 7 litre engine, using a mechanical fuel injection system; making this engine robust for all markets, with the ability to cope the variation in fuel qualities around the world delivering **high quality as standard**.
- Service intervals are set at 500 hours as standard assuming approved fuels and lubricating oils are used to deliver **low operating costs**.

- Throughout the entire life of a Perkins engine, we provide access to genuine factory specification parts giving reassurance that you receive excellent quality for the **lowest possible cost**, wherever your Perkins powered machine is operating in the world.
- Through an experienced global network of distributors and dealers, fully trained engine experts deliver total service support around the clock, 365 days a year. They have a comprehensive suite of web based tools at their finger tips, covering technical information, parts identification and ordering systems, all dedicated to **maximising the productivity** of your engine.

Perkins actively pursues product support excellence with our distribution network investing in their territory to provide you with a consistent quality of support across the globe.

1106A-70TG/TAG Electric Power Engines

Power range 1500 rpm 127-202 kW (engine gross power)

Power range 1800 rpm 146-206 kW (engine gross power)

Emissions Fuel Optimised

Specification

	Model			
	1106A-70TG1	1106A-70TAG2	1106A-70TAG3	1106A-70TAG4
Configuration	ElectropaK			
Cylinders	6 vertical in-line			
Displacement, litres (in3)	7.01 (428)			
Aspiration	Turbocharged	Turbocharged aftercooled		
Bore and stroke, mm (in)	105 x 135 (4.13 x 5.31)			
Combustion system	Direct injection			
Compression ratio	18.2:1		16:1	
Exhaust aftertreatment	N/A			
Rotation (viewed from flywheel)	Anti-clockwise, viewed on flywheel			
Total lubricating oil capacity, litres (US gal)	18 (4.7)			
Cooling system	Liquid			
Total coolant capacity, litres (US gal)	21 (5.5)			

Standard equipment

	Model			
	1106A-70TG1	1106A-70TAG2	1106A-70TAG3	1106A-70TAG4
Electro unit or ElectropaK	ElectropaK	ElectropaK	ElectropaK	ElectropaK
Radiator fitted	✓	✓	✓	✓
Fuel filter, engine mounted	✓	✓	✓	✓
Water separator	N/A	N/A	N/A	N/A
Fuel priming pump (manual/electric)	Manual	Manual	Manual	Manual
Fuel cooler (not required for most installations)	N/A	N/A	N/A	N/A
Air filter, engine mounted	✓	✓	✓	✓
Engine ECM, engine mounted	N/A	N/A	N/A	N/A
Wiring harness to ECM	N/A	N/A	N/A	N/A
Wiring harness (all connectors to single customer interface)	N/A	N/A	N/A	N/A
Starter motor	✓	✓	✓	✓
Battery charging alternator	✓	✓	✓	✓
Flywheel housing	✓	✓	✓	✓
Flywheel	✓	✓	✓	✓
Fan	✓	✓	✓	✓
Fan guard	✓	✓	✓	✓
Temperature and oil pressure for automatic stop/alarm configurable	✓	✓	✓	✓

1106A-70TG/TAG Electric Power Engines

Power range 1500 rpm 127-202 kW (engine gross power)

Power range 1800 rpm 146-206 kW (engine gross power)

Emissions

Fuel Optimised

Technical information

Model	Speed	Type of Operation	Engine Power		Typical Generator Output* (Net)		Prime Fuel Consumption			
			Gross	Net			110%	100%	75%	50%
	rpm		kW (hp)	kW (hp)	kVA	kWe	g/kWh	g/kWh	g/kWh	g/kWh
1106A-70TG1	1500	Prime	127 (170)	118 (159)	135	108	206	203	205	214
		Standby	139 (186)	131 (176)	150	120				
	1800	Prime	146 (196)	134 (179)	152	122	210	211	211	209
		Standby	160 (215)	148 (199)	169	135				
1106A-70TAG2 (Non-Switchable)	1500	Prime	140 (188)	131 (176)	150	120	201	203	200	198
		Standby	154 (206)	144 (193)	165	132				
	1800	Prime	161 (216)	147 (197)	169	135	203	205	208	202
		Standby	177 (237)	164 (220)	188	150				
1106A-70TAG2 (Switchable)	1500	Prime	140 (188)	131 (176)	150	120	198	199	199	203
		Standby	154 (206)	144 (193)	165	132				
	1800	Prime	157 (211)	145 (194)	166	132	205	207	212	204
		Standby	173 (232)	160 (215)	183	147				
1106A-70TAG3 (Non-Switchable)	1500	Prime	169 (224)	158 (212)	180	144	207	208	211	200
		Standby	186 (249)	175 (235)	200	160				
	1800	Prime	187 (251)	173 (231)	197	158	213	214	218	211
		Standby	206 (276)	192 (257)	219	175				
1106A-70TAG3 (Switchable)	1500	Prime	169 (224)	158 (212)	180	144	203	204	209	194
		Standby	186 (249)	175 (235)	200	160				
	1800	Prime	185 (248)	172 (231)	197	157	217	215	222	206
		Standby	204 (274)	190 (255)	217	173				
1106A-70TAG4	1500	Prime	184 (247)	174 (240)	200	160	209	213	215	215
		Standby	202 (271)	191 (256)	220	176				

*Generator powers are typical and based on typical alternator efficiencies and a power factor (cos θ) or 0.8.

1106A-70TG/TAG Electric Power Engines

Power range 1500 rpm 127-202 kW (engine gross power)

Power range 1800 rpm 146-206 kW (engine gross power)

Emissions Fuel Optimised

Engine package weights and dimensions

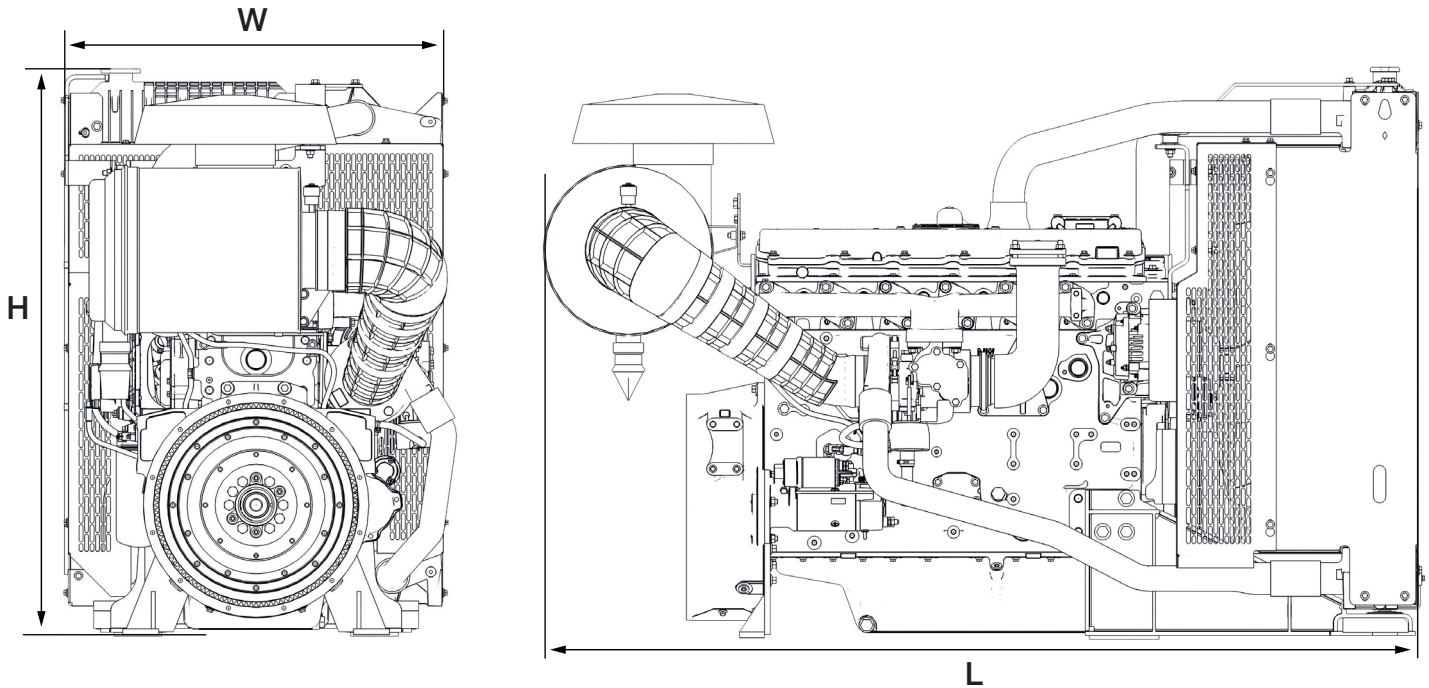

	Model			
	1106A-70TG1	1106A-70TAG2	1106A-70TAG3	1106A-70TAG4
Configuration	ElectropaK			
Dimensions, H x L x W, mm (in)	1042 x 1509 x 760 (41 x 59.4 x 29.9)	1092 x 1706 x 756 (43 x 67.2 x 29.8)		
Dry weight, kg (lb)	739 (1629)	743 (1638)		

Prime power: Power available at variable load in lieu of a main power network. Overload of 10% is permitted for 1 hour in every 12 hours of operation.

Standby (maximum): Power available at variable load in the event of a main power network failure. No overload is permitted.