

# C12.9

## MARINE PROPULSION ENGINE

850 mhp

(838 bhp)

625 bkW

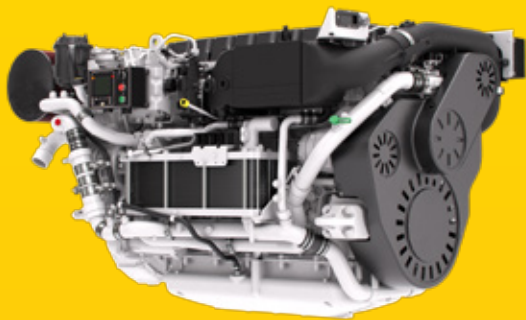

Image shown may not reflect actual engine

## SPECIFICATIONS

### I-6, 4-Stroke-Cycle-Diesel

- Recreational Certifications
  - EPA Tier 3 (E5 Cycle – Recreational Only)
  - IMO II (EPA, GL, CCS, and SeeBG)
  - Recreational Craft Directive (EU) RCD
- Commercial Certifications
  - EU Stage IIIA
  - IMO II (GL, CCS, and SeeBG)
  - CCNR Stage II through reciprocity with EU Stage IIIA
- 12.9 L displacement
- 2300 rpm rated speed
- 135 mm (5.31 in) bore x 150 mm (5.91 in) stroke
- Electronically governed
- Common rail fuel system
- Series turbocharged, aftercooled
- Heat exchanger cooled
- Refill capacity
  - Lube oil system: 47 L (10.3 gal)
  - Cooling system: 45 L (9.9 gal)
- SAE No. 1 flywheel housing  
SAE No. 14 flywheel (155 teeth)
- 250-hour oil change interval
- Counterclockwise rotation



## FEATURES

- High power density
- Industry-leading torque and throttle response at low speed
- Smooth, quiet operation throughout the entire operating range
- Closed crankcase ventilation system improves engine room cleanliness
- Common rail fuel system enables optimum combustion, low emissions and reduced noise
- Available on-engine control panel with “Start,” “Stop,” and display for engine diagnostics
- Inlet air heater for improved cold weather startability
- Low maintenance (fresh water/coolant) aftercoolers
- 12V or 24V electrical system
- **glink** ready for remote engine and vessel monitoring

## DIMENSIONS

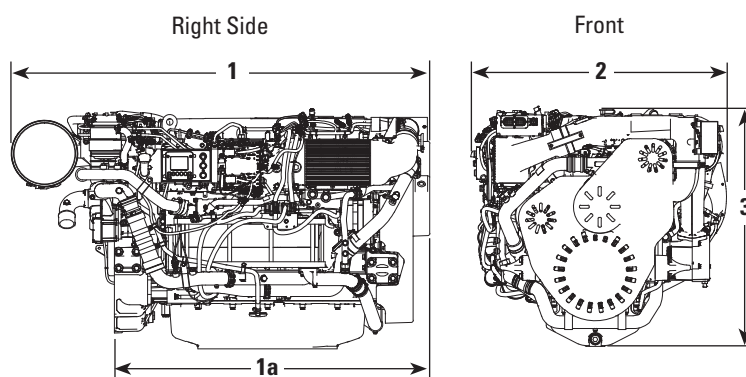

### ENGINE DIMENSIONS & WEIGHT

<b>(1) Length</b>	1960 mm	77.1 in
<b>(1a) Length to flywheel housing</b>	1476 mm	58.1 in
<b>(2) Width</b>	1195 mm	47.0 in
<b>(3) Height</b>	1117 mm	43.9 in
<b>Weight, dry (approx.)</b>	1633 kg	3600 lb

Note: Do not use these dimensions for installation design. See general dimension drawings for detail.

### MARINE ENGINE PERFORMANCE

**Max Power  
E Rating – EM0871**

rpm	bhp	g/hr	bkW	g/bkW-hr
2300	838	43.3	625	220.1
2000	797	40.0	595	213.4
1800	720	34.5	537	203.8
1300	523	23.1	390	188.5
950	329	16.0	245	207.4
600	82	4.3	61	222.6

**Prop Demand  
E Rating – EM0871**

rpm	bhp	g/hr	bkW	g/bkW-hr
2300	838	43.3	625	220.1
2000	553	28.2	412	217.3
1800	402	20.3	300	214.4
1300	152	8.0	113	223.9
950	59	3.3	44	241.0
600	15	1.1	11	305.6

### STANDARD ENGINE EQUIPMENT

- Series turbochargers with heat shield
- Watercooled exhaust manifold
- Dual aftercoolers
- Closed crankcase ventilation system
- Thermostats and housing
- Gear-driven sea water pump with bronze impeller
- Common rail fuel system
- Plate-type heat exchanger
- Engine oil cooler
- Engine-mounted fuel cooler
- Vibration damper and guard
- Grid heater
- Electric fuel priming pump
- Seawater pump outlet pressure sensor
- Water-in-fuel detection switch
- Exhaust gas stack temperature sensor
- Coolant level sensor

### OPTIONAL ATTACHMENTS

- Alternators
  - 24V 120 amp
  - 24V 160 amp
  - 12V 200 amp
- Transmission gear oil cooler
- Transmission sensor packages for on- or off-vessel monitoring
- Instrument panel – MECP I
- Electric starting motor
  - 12V
  - 24V

### RATING DEFINITIONS AND CONDITIONS

#### E Rating (High Performance)

**Typical applications:** For vessels operating at rated load and rated speed up to 8% of the time, or 1/2 hour out of 6, (up to 30% load factor). Typical applications could include but are not limited to vessels such as

pleasure craft, harbor patrol boats, harbor master boats, some fishing or patrol boats. Typical operation ranges from 250 to 1000 hours per year.