

216B3/226B3

Skid Steer Loaders



	216B3		226B3	
Engine				
Engine Model	Cat® C2.2		Cat C2.2 T	
Net Power (SAE 1349/ISO 9249)	35 kW	47 hp	42 kW	56 hp
Weights				
Operating Weight	2581 kg	5,690 lb	2641 kg	5,822 lb
Operating Specifications				
Rated Operating Capacity	635 kg	1,400 lb	680 kg	1,500 lb

Features

Comfortable Operator Station

Spacious, comfortable cab and ergonomic, low effort joystick controls reduce operator fatigue.

High Performance Power Train

High horsepower and torque deliver outstanding performance.

Advanced Hydraulic System

Hydraulic system provides maximum power and reliability for demanding applications.

More Work Tools

Caterpillar's broad range of performance matched work tools make the Cat skid steer loader the most versatile machine on the job site.



Contents

Operator Station.....	3
Hydraulics	4
Power Train.....	5
Work Tools.....	6
Serviceability	7
Customer Support.....	7
Specifications.....	8
Standard Equipment.....	10
Optional Equipment.....	11

The Cat® B3 Series Skid Steer Loader, with its many work tool options, delivers outstanding performance to help you get more done and increase your bottom line. Spacious, ergonomic operator station and easy-to-use pilot operated joystick controls keep you comfortable throughout the work day. High performance power train, advanced hydraulic system and traditional Cat reliability improve your productivity in the toughest working conditions.



Operator Station

Superior comfort to keep you productive throughout the work day.

All Day Comfort

Comfort and ease of operation have been designed into every aspect of the operator station. The wide, spacious interior and uncluttered floor provide a comfortable work environment with excellent head, shoulder and leg room to keep productivity high and fatigue low. The adjustable seat and low effort controls keep the operator comfortable throughout the work day.

Low Effort Joystick Controls

Ergonomic, pilot hydraulic controls deliver precise control with minimal effort. The right joystick controls the loader raise, lower and tilt functions while the left joystick controls the forward and reverse travel speed plus direction. Optional deluxe joysticks provide additional auxiliary controls with fingertip control of many work tool functions, including proportional work tool hydraulics and work tool electrical. Basic and deluxe joystick functions include one-touch continuous auxiliary hydraulic flow and momentary auxiliary hydraulic flow.

Excellent Visibility

The wide cab opening offers an exceptional view to the work tool. The sloped angle of the engine compartment allows excellent visibility to the rear of the machine. The standard rear view mirror gives the operator a panoramic view of the machine's rear and sides. The side windows remove easily for cleaning.

Additional Features for Maximum Comfort

The B3 Series machines offer the following additional features to help you on the job:

- Suspension seat option for even greater operator comfort.
- Easy to read instrument panels.
- Optional air conditioner and heater for greater comfort in extreme conditions.
- Standard floor mat with footrest provides non-slip surface and can be removed for easy cleaning.
- Ergonomic, contoured and padded armbar provides comfortable operation.



Hydraulics

Exceptional lift, breakout and power to meet your needs.

High Performance Hydraulic System

Maximum power and reliability are built into the machine's hydraulic system. In addition to providing power to the wheels, this system also provides the loader lift and tilt functions, powers the auxiliary circuit to drive work tools and drives the engine cooling fan. The hydraulic pumps are driven directly off the engine for maximum hydraulic performance and reliability – no belts are used. The hydraulic system also features:

- Standard auxiliary hydraulics to power work tools that are available through quick connect hydraulic couplings rigidly mounted to the loader arm.
- Cat ToughGuard™ hoses for increased reliability and durability.

High Flow Hydraulics

High flow hydraulic system is available on the 226B3 for greater machine versatility and increased work tool performance.

High Efficiency Cooling System

Cooling capacity is maximized through the use of a side-by-side cooling package and hydraulically driven cooling fan.

- High-efficiency, hydraulic oil cooler lets the machine work longer and harder in higher ambient temperatures, even with continuous work tool usage.
- Efficient, hydraulically driven cooling fan provides cooling even when the machine is under load.
- Optional variable speed demand fan provides improved fuel efficiency, increased machine performance, reduced sound levels and improved cold weather performance.



Power Train

Aggressive performance with fuel efficiency.

Cat® Engine

The high performance power train provides high engine horsepower and torque. The B3 Series machines feature rugged, reliable Cat engines that meet U.S. EPA Tier 3 and EU Stage IIIA emissions requirements. The 216B3 and 226B3 engine also meet Brazil Mar-1 emission standards which is equivalent to EU Stage IIIA.

Hand and Foot Throttles

Hand and foot throttles allow the operator to match engine speed to the task. The hand throttle is ideal for jobs requiring constant engine speed such as cold planing, trenching or snow blowing. The foot throttle lets the operator vary engine speed and minimize fuel consumption for other tasks such as load and carry, truck loading, grading and dozing.

Anti-Stall Feature

The anti-stall system maximizes machine power at all times by matching the engine torque with the operational requirements of the hystat and implement systems. This load sensing feature prevents the engine from stalling even during part throttle operation, keeping productivity high and fuel consumption low.

Work Tools

Do more jobs with one machine with Cat[®] Work Tools.

The Right Tool for the Job

Get the most out of your machine with the comprehensive line of Cat work tools. Designed and built for optimum performance and durability, these tools deliver high productivity in a variety of applications to maximize the versatility and flexibility of the Cat skid steer loader:

- Augers
- Backhoes
- Blades (angle, dozer)
- Buckets (general purpose, high capacity, dirt, utility, light material, multi purpose, industrial grapple, utility grapple)
- Brooms (angle, pickup, utility)
- Brushcutters
- Cold Planers
- Forks (pallet, industrial grapple, utility grapple, utility)
- Hydraulic Hammers
- Landscape Tillers
- Landscape Rakes
- Material Handling Arm
- Power Box Rakes
- Shear
- Snow Blowers
- Stump Grinders
- Trenchers
- Vibratory Compactors
- Wheel Saws

Quick Couplers

Work tools can be changed quickly and easily with the machine's quick coupler system. The standard quick coupler features manual engagement and disengagement of work tools using two high leverage handles. The optional hydraulic quick coupler allows the operator to quickly change tools without leaving the cab.



Serviceability

Simplified service and maintenance
save you time and money.

Easy Service

Convenient service features make maintenance easy, reducing your downtime:

- Industry exclusive tilt-up cooling package provides superior access to service points and coolers.
- Rear door opens 90 degrees for easy access to both sides of the engine.
- Cab tilts rearward for easy access to all hydraulic pumps, motors, valves, lines and hydraulic tank.
- Daily maintenance points are easily accessible.
- Electrical wiring is color coded and numbered for easy identification.
- S-O-SSM oil sampling valve is standard to allow regular monitoring of the hydraulic oil quality.

Customer Support

Support you can count on.



Superior Dealer Services

Your Cat dealer is ready to assist you with your purchase decision and everything after.

- Make comparisons of machines, with estimates of component life, preventative maintenance and cost of production.
- Financing packages are flexible to meet your needs.
- Your Cat dealer can evaluate the cost to repair, rebuild and replace your machine, so you can make the right decision.
- For more information on Cat products, dealer services and industry solutions, visit us at www.cat.com.

B3 Series Skid Steer Loaders Specifications

Engine

Engine Model		
216B3	Cat C2.2	
226B3	Cat C2.2 T	
Net Power (SAE 1340/ISO 9249)		
216B3	35 kW	47 hp
226B3	42 kW	56 hp
Gross Power (SAE J1995)		
216B3	38 kW	51 hp
226B3	45.5 kW	61 hp
Displacement		
	2.2 L	134 in ³
Stroke		
	100 mm	3.9 in
Bore		
	84 mm	3.3 in

Weights*

Operating Weight		
216B3	2581 kg	5,690 lb
226B3	2641 kg	5,822 lb

Operating Specifications*

Rated Operating Capacity		
216B3	635 kg	1,400 lb
226B3	680 kg	1,500 lb
Rated Operating Capacity with Optional Counterweight		
216B3	680 kg	1,500 lb
226B3	726 kg	1,600 lb
Tipping Load		
216B3	1270 kg	2,800 lb
226B3	1360 kg	3,000 lb
Breakout Force, Tilt Cylinder		
	1852 kg	4,083 lb

*Operating Weight, Operating Specifications and Dimensions all based on 75 kg (165 lb) operator, all fluids, 1 speed, OROPS, dirt bucket, tires, no optional counterweights and manual quick coupler (unless otherwise noted).

Hydraulic System

Hydraulic Flow		
Standard		
Loader Hydraulic Pressure	23 000 kPa	3,335 psi
Loader Hydraulic Flow	61 L/min	16 gal/min
Hydraulic Power (calculated)	23.2 kW	31.1 hp
Hydraulic Flow		
High Flow – 226B3		
Loader Hydraulic Pressure	23 000 kPa	3,335 psi
Loader Hydraulic Flow	104 L/min	27 gal/min
Hydraulic Power (calculated)	37.7 kW	50.6 hp

Cab

ROPS	ISO 3471:2008	
FOPS	ISO 3449:2005 Level I	

Power Train

Travel Speed (Forward or Reverse)	12.7 km/h	7.9 mph
-----------------------------------	-----------	---------

Service Refill Capacities

Chain Box, each side	6 L	1.6 gal
Cooling System	10 L	2.6 gal
Engine Crankcase	10 L	2.6 gal
Fuel Tank	58 L	15.4 gal
Hydraulic System	55 L	14.5 gal
Hydraulic Tank	35 L	9.2 gal

Model availability may vary by region.

B3 Series Skid Steer Loaders Specifications

Dimensions

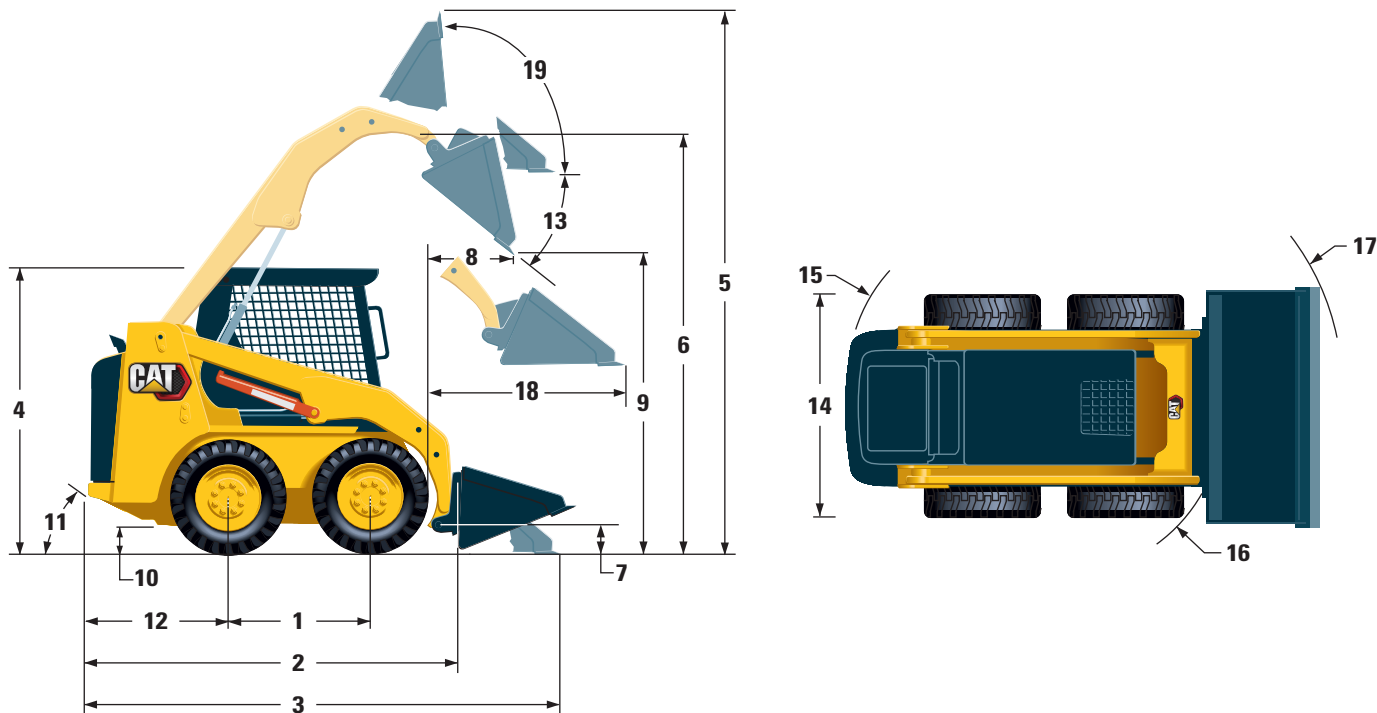

	216B3/226B3	
	mm	in
1 Wheelbase	986	39
2 Length without Bucket	2519	99
3 Length with Bucket on Ground	3233	127
4 Height to Top of Cab	1950	77
5 Maximum Overall Height	3709	146
6 Bucket Pin Height at Maximum Lift	2854	112
7 Bucket Pin Height at Carry Position	200	8
8 Reach at Maximum Lift and Dump	505	20
9 Clearance at Maximum Lift and Dump	2169	85.4
10 Ground Clearance	195	8
11 Departure Angle		26°
12 Bumper Overhang Behind Rear Axle	967	38
13 Maximum Dump Angle		40°
14 Vehicle Width over Tires	1525	60
15 Turning Radius from Center – Machine Rear	1502	59
16 Turning Radius from Center – Coupler	1195	47
17 Turning Radius from Center – Bucket	1944	77
18 Maximum Reach with Arms Parallel to Ground	1291	51
19 Rack Back Angle at Maximum Height		81°

B3 Series Skid Steer Loaders Standard Equipment

Standard Equipment

Standard equipment may vary. Consult your Cat dealer for details.

ELECTRICAL

- 12 volt Electrical System
- 65 ampere Alternator (216B3)
- 85 ampere Alternator (226B3)
- Automatic Glow Plug Activation
- Ignition Key Start/Stop Switch
- Lights: Gauge backlighting, two rear tail lights, two adjustable front and rear halogen lights, dome light.

OPERATOR ENVIRONMENT

- Gauges: Fuel level, hour meter
- Operator Warning System Indicators: Air filter restriction, alternator output, armrest raised/operator out of seat, engine coolant temperature, engine oil pressure, glow plug activation, hydraulic filter restriction, hydraulic oil temperature, parking brake engaged
- Vinyl seat
- Pull Down Ergonomic Contoured Armrest
- Control Interlock System, when operator leaves seat or armrest raised: Hydraulic system disables, hydrostatic transmission disables, parking brake engages
- ROPS Cab, Open, Tilt Up
- FOPS, Level I
- Top and Rear Windows
- Floor Mat
- Interior Rear View Mirror
- 12 volt Electric Socket
- Horn
- Backup Alarm
- Hand and Foot Throttle

POWER TRAIN

- Cat C2.2 Diesel Engine (216B3)
- Cat C2.2 T Diesel Engine (226B3)
- Engines are EU Stage IIIA
- Engine meets Brazil Mar-1 emission standards equivalent to Stage IIIA (226B3 only)
- Air Cleaner, Dual Element, Radial Seal
- S-O-SSM Sampling Valve, Hydraulic Oil
- Filters, Spin-on, Hydraulic
- Filters, Bayonet-type, Fuel and Water Separator
- Tilt Up Radiator/Hydraulic Oil Cooler
- Spring Applied, Hydraulically Released Parking Brakes
- Hydrostatic Transmission
- Four Wheel Chain Drive

OTHER

- Engine Enclosure, Lockable
- Extended Life Antifreeze, -36° C (-33° F)
- Machine Tie Down Points (4)
- Support, Lift Arm
- Hydraulic Oil Level Sight Gauge
- Radiator Coolant Level Sight Gauge
- Radiator, Expansion Bottle
- Cat ToughGuard™ Hose
- Auxiliary, Hydraulics, Continuous Flow
- Heavy Duty, Flat Faced Quick Disconnects
- Split D-Ring to Route Work Tool Hoses Along Side of Left Lift Arm
- Electrical Outlet, Beacon
- Belly Pan Cleanout

MANDATORY EQUIPMENT

- Quick Coupler, Mechanical or Hydraulic
- Seat Belt, 50 mm (2 in) or 75 mm (3 in)
- Cooling Fan, Demand or Standard

- Comfort Packages (must select one of the following):
 - Open ROPS (C0): Static Seat
 - Open ROPS (C1): Suspension Seat, Deluxe Headliner
 - Enclosed ROPS (C2): Features of C1 Package plus Heater, Cab Door, Side Windows, Cup Holder, Cab Debris Barrier
 - Enclosed ROPS (C3): Features of C2 Package plus Air Conditioner (not available on the 216B3)

- Control Packages (must select one of the following):
 - Control Package 1: On/Off Auxiliary Hydraulics Basic
 - Control Package 2: Proportional Auxiliary Hydraulics Deluxe
 - Control Package 3: Proportional Auxiliary Hydraulics Deluxe, Work Tool Harness
 - Control Package 4: High Flow Hydraulics (226B3 only)

B3 Series Skid Steer Loaders Optional Equipment

Optional Equipment

Optional equipment may vary. Consult your Cat dealer for details.

- Variable Speed Demand Fan (not available in all regions)
- Counterweight
- Beacon, Rotating
- Engine Block Heater, 120V or 240V
- Heavy Duty Battery, 880 CCA
- Oil, Hydraulic, Cold Operation
- Door, Glass or Polycarbonate
- Self-Leveling
- Paint, Custom



For more complete information on Cat products, dealer services, and industry solutions, visit us on the web at www.cat.com

© 2021 Caterpillar
All rights reserved

Materials and specifications are subject to change without notice. Featured machines in photos may include additional equipment. See your Cat dealer for available options.

CAT, CATERPILLAR, LET'S DO THE WORK, their respective logos, "Caterpillar Corporate Yellow," the "Power Edge" and Cat "Modern Hex" trade dress as well as corporate and product identity used herein, are trademarks of Caterpillar and may not be used without permission.

AEHQ8341 (02-2021)
Replaces AEHQ6131
(APD, S Am, EAME – LRC Regions)

