



Cat[®] Hydraulic Connecting S Type

Excavator Couplers

Technical Specifications

Not all attachments available in all regions. Consult your Cat[®] dealer for specific configurations available in your region.

Table of Contents

Specifications	2
Quick Disconnects	2
Dimensions	3
Matching	4
Machine Matching	4
Hydromechanical Matching	5
Bucket Matching	6
Options	7

Hydraulic Connecting S Type Couplers

Specifications

The following information is specific to just the couplers. Consult your dealer on appropriate coupler and bracket compatibility for your attachments.

Model	Part Number	Linkage	Carrier Weight, Maximum	Permitted Positive Torque*	Permitted Negative Torque*	Weight		Lift Hook Capacity	
			ton	kN·m	kN·m	kg	lb	ton	lb
HCS60	582-8807	M312	19	165	108	173	381	5	10,000
	590-2376	312	19	165	108	147	324	5	10,000
	590-2377	315	19	165	108	174	384	5	10,000
HCS65	590-2379	M312	20	240	156	208	459	5	10,000
	590-2380	312	20	240	156	191	421	5	10,000
	583-0661	315	20	240	156	212	467	5	10,000
HCS70	582-8929	B/M320	30	300	195	290	639	8	16,000
	580-0407	CB	30	300	195	315	694	8	16,000
	598-7847	UHD	30	300	195	332	732	8	16,000
HCS70/55	582-9886	B/M320	30	350	228	325	717	8	16,000
	582-9976	CB	30	350	228	346	763	8	16,000
	598-7849	UHD	30	350	228	360	794	8	16,000
HCS80	583-0203	CB	40	500	325	429	946	10	20,000
	583-0212	DB	40	500	325	459	1,012	10	20,000

*When paired with a Cat machine, torque limits do not present a concern for the coupler.

Quick Disconnects

Model	Part Number	Linkage	Installed				Optional	
			3/8	1/2	3/4	1	1/2	3/4
HCS60	582-8807	M312	2		2		1	
	590-2376	312	2		2		1	
	590-2377	315	2		2		1	
HCS65	590-2379	M312		2	2			1
	590-2380	312		2	2			1
	583-0661	315		2	2			1
HCS70	582-8929	B/M320		2		2		1
	580-0407	CB		2		2		1
	598-7847	UHD		2		2		1
HCS70/55	582-9886	B/M320		2		2		2
	582-9976	CB		2		2		2
	598-7849	UHD		2		2		2
HCS80	583-0203	CB		2		2		2
	583-0212	DB		2		2		2

Hydraulic Connecting S Type Couplers

Dimensions

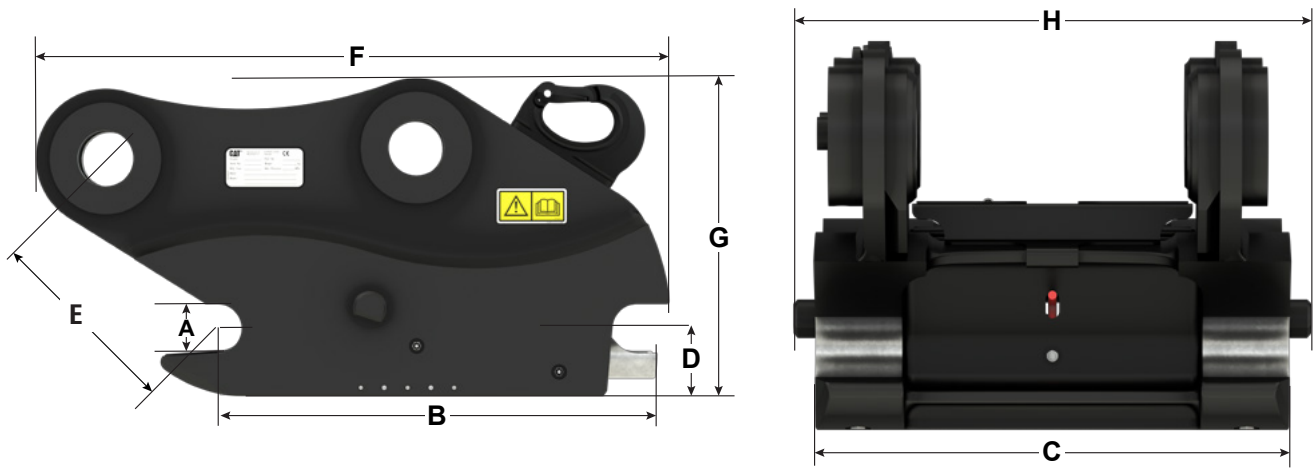

Model	Part Number	(A) Shaft Diameter		(B) Shaft Center to Center		(C) Width		(D) Basic Height		(E) Hinge Distance		(F) Total Length		(G) Total Height		(H) Total Width	
		mm	in	mm	in	mm	in	mm	in	mm	in	mm	in	mm	in	mm	in
HCS60	582-8807	60	2.4	480	18.9	340	13.4	75	3.0	245	9.6	775	30.5	405	15.9	470	18.5
	590-2376	60	2.4	480	18.9	340	13.4	75	3.0	225	8.9	743	29.3	392	15.4	413	16.3
	590-2377	60	2.4	480	18.9	340	13.4	75	3.0	235	9.3	792	31.2	420	16.5	471	18.5
HCS65	590-2379	65	2.6	530	20.9	440	17.3	82	3.2	236	9.3	802	31.6	390	15.4	508	20.0
	590-2380	65	2.6	530	20.9	440	17.3	82	3.2	225	8.9	785	30.9	385	15.2	494	19.4
	583-0661	65	2.6	530	20.9	440	17.3	82	3.2	236	9.3	825	32.5	410	16.1	508	20.0
HCS70	582-8929	70	2.8	600	23.6	450	17.7	97	3.8	301	11.9	907	35.7	467	18.4	525	20.7
	580-0407	70	2.8	600	23.6	450	17.7	97	3.8	306	12.0	928	36.5	522	20.6	564	22.2
	598-7847	70	2.8	600	23.6	450	17.7	97	3.8	319	12.6	933	36.7	525	20.7	549	21.6
HCS70/55	582-9886	70	2.8	600	23.6	550	21.7	97	3.8	291	11.5	907	35.7	455	17.9	607	23.9
	582-9976	70	2.8	600	23.6	550	21.7	97	3.8	296	11.7	928	36.5	510	20.1	607	23.9
	598-7849	70	2.8	600	23.6	550	21.7	97	3.8	309	12.2	935	36.8	513	20.2	607	23.9
HCS80	583-0203	80	3.1	670	26.4	590	23.2	115	4.5	296	11.7	1004	39.5	512	20.2	647	25.5
	583-0212	80	3.1	670	26.4	590	23.2	115	4.5	314	12.4	1042	41.0	538	21.2	647	25.5

Hydraulic Connecting S Type Couplers

Machine Matching

● Optimal

○ Acceptable

■ No Match

	HCS60	HCS65	HCS70	HCS70/55	HCS80
Small Excavators					
311F	●	●			
313F GC	●	●			
313F	●	●			
313 GC	●	●			
313	●	●			
315F	●	●			
315 GC	●	●			
315	●	●			
316F	●	●	○	○	
317 GC	●	●	○	○	
317	●	●	○	○	
318F	●	●	○	○	
Medium Excavators					
320F		○	●	●	
320		○	●	●	
320 GC		○	●	●	
323F		○	●	●	
323		○	●	●	
325F		○	●	●	
325			●	●	
326F			●	●	●
326			●	●	●
330F			●	●	●
330			●	●	●
330 GC			●	●	●
335F			●	●	●
335			●	●	●

	HCS60	HCS65	HCS70	HCS70/55	HCS80
Large Excavators					
336F					●
336F XE					●
336					●
336 GC					●
340F					●
340F UHD			●	●	○
340					●
340 UHD			●	●	○
352 UHD			●	●	○
Wheeled Excavators					
M314F	●	●			
M314	●	●			
M315F	●	●			
M315	●	●			
M316F	●	●			
M316	●	●	○	○	
M317F	●	●	○	○	
M317	●	●	○	○	
M318F	●	●	○	○	
M318	●	●	○	○	
M319	●	●	○	○	
M320F		○	●	●	
M320		○	●	●	
M322F		○	●	●	
M322		○	●	●	
Material Handlers*					
MH3022		○	●	●	
MH3024		○	●	●	
MH3026		○	●	●	

*When equipped with appropriate stick and bucket linkage.
UHD – Ultra High Demolition

Hydraulic Connecting S Type Couplers

Hydromechanical Matching

Check your machine's configuration to determine optimal coupler and attachment combinations.

Match

No Match

Family	Model	HCS60	HCS65	HCS70	HCS70/55	HCS80
Hydraulic Hammers	H110 S	✓	✓			
	H115 S	✓	✓	✓	✓	
	H120 S		✓	✓	✓	✓
	H130 S			✓	✓	✓
	H140 S			✓	✓	✓
	H160 S					✓
Multi-Processors	MP318 Concrete Cutter Jaw		✓	✓	✓	
	MP318 Demolition Jaw		✓	✓	✓	
	MP318 Pulverizer Jaw		✓	✓	✓	
	MP318 Shear Jaw		✓	✓	✓	
	MP318 Universal Jaw		✓	✓	✓	
	MP324 Concrete Cutter Jaw			✓	✓	✓
	MP324 Demolition Jaw			✓	✓	✓
	MP324 Pulverizer Jaw			✓	✓	✓
	MP324 Shear Jaw			✓	✓	✓
	MP324 Tank Shear Jaw			✓	✓	✓
	MP324 Universal Jaw			✓	✓	✓
	MP332 Concrete Cutter Jaw					✓
	MP332 Demolition Jaw					✓
	MP332 Pulverizer Jaw					✓
	MP332 Shear Jaw					✓
	MP332 Universal Jaw					✓
MP332 Tank Shear Jaw					✓	
Demolition and Sorting Grapples	G312 GC	✓	✓			
	G313 GC	✓	✓			
	G314	✓	✓			
	G317 GC	✓	✓	✓	✓	
	G318		✓	✓	✓	
	G318 WH 800		✓	✓	✓	
	G318 WH 1100			✓	✓	
	G324			✓	✓	✓
	G324 WH 1500			✓	✓	✓
	G324 WH 1800			✓	✓	✓
	G324 WH 2000			✓	✓	✓
	G332			✓	✓	✓
	G345					✓
	Mobile Scrap and Demolition Shears	S3015	✓	✓		
S3025				✓	✓	✓
S3035				✓	✓	✓
Pulverizers	P218 Secondary Pulverizer			✓	✓	✓
	P224 Secondary Pulverizer			✓	✓	✓
	P232 Secondary Pulverizer					✓
	P318 Primary Pulverizer			✓	✓	✓
	P324 Primary Pulverizer			✓	✓	✓
	P332 Primary Pulverizer					✓
Compactors (Vibratory Plate)	CVP75	✓	✓			
	CVP110			✓	✓	✓

Hydraulic Connecting S Type Couplers

Bucket Matching

Use with Hydraulic Connecting S Type Couplers or the equivalent OilQuick Dedicated Coupler.

HCS65 Coupler (312-Family)

Part No.	Width		Capacity		Adapters		Weight	
	mm	in	m ³	yd ³	GET	Qty.	kg	lb
General Duty								
489-4228 ^{LE}	600	24	0.32	0.42	K80	3	495	1090
490-5273 ^{LE}	800	31	0.48	0.62	K80	2	601	1325
490-5274 ^{LE}	1000	39	0.64	0.84	K80	4	709	1563
489-4229 ^{LE}	1200	47	0.80	1.04	K80	5	778	1715

*Tips included

LE – Leveling Edge included

NOTE: Bucket profile specifically for M313D, M314F, M315D2/F

HCS70/55 Coupler (315/316-Family)

Part No.	Width		Capacity		Adapters		Weight	
	mm	in	m ³	yd ³	GET	Qty.	kg	lb
General Duty								
490-4017 ^{LE}	600	24	0.35	0.46	K80	3	537	1184
488-8415 ^{LE}	650	25	0.46	0.60	K80	3	602	1328
477-3375 ^{LE}	750	29	0.55	0.72	K80	3	669	1474
490-4018 ^{LE}	800	31	0.55	0.72	K80	3	647	1426
477-3376 ^{LE}	950	37	0.74	0.96	K80	4	782	1723
490-4019 ^{LE}	1000	39	0.74	0.96	K80	4	760	1676
477-3377 ^{LE}	1150	45	0.93	1.21	K80	5	892	1967
490-4020 ^{LE}	1200	47	0.93	1.22	K80	5	872	1922
479-8870 ^{LE}	1350	53	1.12	1.50	K80	5	989	2181
490-4021 ^{LE}	1400	55	1.12	1.50	K80	5	966	2129

*Tips included

LE – Leveling Edge included

HCS70/55 Coupler (B-Family)

Part No.	Width		Capacity		Adapters		Weight	
	mm	in	m ³	yd ³	GET	Qty.	kg	lb
General Duty								
485-7621 ^{LE}	650	25	0.69	0.90	K80	3	709	1556
485-7622 ^{LE}	800	31	0.69	0.90	K80	3	786	1732
573-4984	1000	39	0.87	1.14	80	4	830	1830
477-3378 ^{LE}	1000	39	0.93	1.22	K80	4	910	2006
573-4985	1200	47	1.10	1.43	80	5	938	2068
477-3379 ^{LE}	1200	47	1.18	1.54	K80	5	1033	2277
573-4988 ^{LE}	1300	51	1.30	1.70	80	5	992	2187
477-3380 ^{LE}	1300	51	1.30	1.70	K80	5	1087	2396
573-4986	1400	55	1.33	1.73	80	5	1036	2284
477-3381 ^{LE}	1400	55	1.43	1.87	K80	5	1141	5215
477-3382 ^{LE}	1500	59	1.55	2.02	K80	5	1197	2639

*Tips included

LE – Leveling Edge included

HCS70/55 Coupler (CB-Family)

Part No.	Width		Capacity		Adapters		Weight	
	mm	in	m ³	yd ³	GET	Qty.	kg	lb
General Duty								
490-5275 ^{LE}	1200	47	1.29	1.69	K90	4	1152	2540
490-5276 ^{LE}	1300	51	1.43	1.87	K90	5	1243	2740
490-5277 ^{LE}	1400	55	1.57	2.05	K90	5	1297	2859
573-4989	1600	63	1.80	2.35	90	5	1232	2716
490-5279 ^{LE}	1600	63	1.84	2.40	K90	6	1439	3172

*Tips included

LE – Leveling Edge included

Hydraulic Connecting S Type Couplers

Options

Model	Part Number	Linkage	Options	
			Extra/Drain QDC Valve	Grease Kit, Valves M&F (not installed)
HCS60	582-8807	M312	590-2391 (1x)	617-2074 (3/8") 617-2075 (1/2")
	590-2376	312		
	590-2377	315		
HCS65	590-2379	M312	580-0421 (1x)	617-2075 (1/2") 617-2077 (3/4")
	590-2380	312		
	583-0661	315		
HCS70	582-8929	B/M320	580-0421 (1x)	617-2076 (1/2") 617-2079 (3/4")
	580-0407	CB		
	598-7847	UHD		
HCS70/55	582-9886	B/M320	580-0421 (1x or 2x)	617-2076 (1/2") 617-2079 (3/4")
	582-9976	CB		
	598-7849	UHD		
HCS80	583-0203	CB	580-0421 (1x or 2x)	617-2076 (1/2") 617-2079 (3/4")
	583-0212	DB		

For more complete information on Cat products, dealer services, and industry solutions, visit us on the web at www.cat.com

GEJQ9392-01 (11-2021)
Replaces GEJQ9392
(EU, N Am, S Am)

© 2021 Caterpillar
All rights reserved

Materials and specifications are subject to change without notice. Featured machines in photos may include additional equipment. See your Cat dealer for available options.

CAT, CATERPILLAR, LET'S DO THE WORK, their respective logos, "Caterpillar Corporate Yellow," the "Power Edge" and Cat "Modern Hex" trade dress as well as corporate and product identity used herein, are trademarks of Caterpillar and may not be used without permission.

