



D1/D2/D3 SMALL DOZER PARTS REFERENCE GUIDE

LET'S DO THE WORK.™



PROTECT YOUR INVESTMENT WITH GENUINE CAT® PARTS

Thank you for selecting the Cat® Small Dozer.

This guide is designed to provide you with a quick reference for the parts and part numbers you need to keep your Cat Small Dozer running at peak efficiency.



MAINTENANCE

Proactive preventative maintenance extends the life of your machine and protects your investment. Only Caterpillar knows Cat equipment's filtration and lubrication requirements and offers parts to match your machine's maintenance cycles.

SCHEDULED MAINTENANCE PARTS	
	GREASES
	PLANNED MAINTENANCE PARTS

REPLACEMENT PARTS

Proper maintenance minimizes the need for repair and replacement. In the event that replacement parts are required, the use of genuine Cat parts helps maximize machine performance and maintains high resale value.

WEAR PARTS	
	UNDERCARRIAGE
	GROUND ENGAGING TOOLS
REPAIR PARTS	
	ENGINE PARTS
	DIESEL EXHAUST FLUID
	LIGHTS
	BATTERIES
	SEAT BELT
	CAB GLASS
	WIPERS

GREASES

Previous Cat Product Name	STANDARD MAINTENANCE GREASES			GREASES FOR UNIQUE APPLICATIONS AND ENVIRONMENTS			
	Cat Ultra 5 Moly #1	Cat Ultra 5 Moly #2	Cat Advanced 3 Moly	Cat Arctic Platinum	Cat Desert Gold	Cat Multipurpose	Hammer Paste
Current Cat Product Name	Cat Extreme Application Grease - 1 (5% MOS2)	Cat Extreme Application Grease - 2 (5% MOS2)	Cat Prime Application Grease (3% MOS2)	Cat Extreme Application Grease - Arctic (5% MOS2)	Cat Extreme Application Grease - Desert (5% MOS2)	Cat Utility Grease	
Grade (NLGI)	1	2	2	0	2	2	2
Melting Point °C (°F)	260 (500)	260 (500)	260 (500)	230 (446)	280 (536)	260 (500)	230 (446)
Ambient Temperature °C (°F)	-35 to +40 (-31 to +104)	-30 to +50 (-22 to +122)	-20 to +40 (-4 to +104)	-35 to +40 (-31 to +104)	-30 to +50 (-22 to +122)	-30 to +40 (-22 to +104)	-20 to +1100 (-4 to +2012)
Base Oil Type	Mineral	Mineral	Mineral	Semi-Synthetic	Mineral	Mineral	Mineral
Color	Dark Grey	Dark Grey	Dark Grey	Dark Grey	Dark Grey	Blue	Bronze
Cartridge (390 g / 14 oz)	452-5996	452-6001	452-6006	508-2184	452-6016	452-6011	130-6951 (standard) 317-8491 (autolube)
Plastic Pail (5 kg / 11 lb)	–	–	–	–	–	–	133-8807
Plastic Pail (16 kg / 35 lb)	452-5999	452-6004	452-6009	508-2187	452-6019	452-6014	–
Keg (55 kg / 120 lb)	452-5998	452-6003	452-6008	508-2186	452-6018	452-6013	–
Drum (180 kg / 400 lb)	452-5997	452-6002	452-6007	508-2185	452-6017	452-6012	–

MAINTENANCE FLUIDS	TYPE
Engine Oil	Cat DEO™ (10W-30)
Hydraulic Oil	Cat HYDO™ Advanced 10
Final Drive Oil	Cat TDTO SAE 50W
Coolant	Cat ELC™

PLANNED MAINTENANCE PARTS D1/D2/D3

The following abbreviations are used in the charts throughout this guide:
Quantity is abbreviated as Qty

SMALL DOZERS		EVERY 500 HOURS									
		Cabin Air		Cabin Air		Engine Oil/Filter Change		Air Filter		Fuel Filter Change	
Sales Model	Serial # Prefix	Fresh Air Filter with A/C - Alternative	Fresh Air Filter with Spark Arrestor	Recirculating Element AC	Recirculating Element No AC	Filter	Oil Qty (L) DEO-ULS™	Primary Element Clean or Replace	Secondary Element	Primary Element	Secondary Element
D1/D2/D3	XKF, XKL, XT3, XKM, XKR, XKW, XKY, XT5	266-7765	476-7104	443-2127	443-2127	569-8036	10.5	526-3120	526-3124	523-6604	360-8960

SMALL DOZERS		EVERY 1,500 HOURS		EVERY 2,000 HOURS			EVERY 3,000 HOURS		EVERY 6,000 HOURS	
		Drive Belt		Hydraulic Filter Change		Final Drive Oil Change	Winch Oil Change	Hydraulic Tank	DEF Filter	Hydraulic Oil
Sales Model	Serial # Prefix	D1	D2 and D3	Filter Unit	Winch Filter (if equipped)	Oil Qty (L) TDTO	Oil Qty (L) TDTO	Breather Element	Filter	Oil Qty (L) Hydo Adv
D1/D2/D3	XKF, XKL, XT3, XKM, XKR, XKW, XKY, XT5	with A/C = 524-2467 without A/C = 525-7711	with A/C = 515-2097 without A/C = 520-3849	421-5481	421-5479	10 per side	19	9R-9925 (Qty 2)	378-3187	50

1500 and 2000 hour cycles include the 500 hour part numbers. 3000 hour cycle includes 500 and 1500 hour part numbers. 6000 hour cycle includes 500, 1500, and 3000 hour part numbers.

UNDERCARRIAGE D1/D2/D3

SMALL DOZERS		SALT Undercarriage						
		Rollers (per side)			Segments (per side)	Idler Group (per side)	Idler Assembly (per side)	Link Assembly (per side)
Sales Model	Serial Number Prefix	Single Flange	Double Flange	Carrier				
D1/D2	XKF, XKL, XT3, XKM, XKR	497-8871 (QTY 4)	497-8958 (QTY 2)	6S-3609	278-2355 (QTY 1) 278-2356 (QTY 5)	499-9105	533-5536	323-8755
D3	XKW, XKY, XT5	346-8807 (QTY 4)	347-0406 (QTY 3)	6K-9880	278-2358 (QTY 3) 278-2359 (QTY 3)	419-5476	399-0736	289-0270

SMALL DOZERS		SALT Track									
		Shoes and Hardware (per side)									
Sales Model	Serial Number Prefix	Description	D1	D1 LGP	D1 LGP (762 MM/30 IN)	D2	D2 LGP	D3	D3 LGP	D3 LGP (762 MM/30 IN)	
D1/D2	XKF, XKL, XT3, XKM, XKR	Track Bolt	4K-7038 (QTY 168)	4K-7038 (QTY 168)	4K-7038 (QTY 168)	4K-7038 (QTY 168)	4K-7038 (QTY 168)	4K-7038 (QTY 168)	9G-3110 (QTY 156)	9G-3110 (QTY 156)	9G-3110 (QTY 156)
		Master Track Bolt	5A-3187 (QTY 4)	5A-3187 (QTY 4)	5A-3187 (QTY 4)	5A-3187 (QTY 4)	5A-3187 (QTY 4)	5A-3187 (QTY 4)	9G-8592 (QTY 2)	3T-8601 (QTY 2)	9G-8592 (QTY 2)
		Track Nut	7K-2017 (QTY 168)	7K-2017 (QTY 168)	7K-2017 (QTY 168)	7K-2017 (QTY 168)	7K-2017 (QTY 168)	7K-2017 (QTY 168)	1M-1408 (QTY 156)	1M-1408 (QTY 156)	1M-1408 (QTY 156)
		Track Shoe	198-6987 (QTY 42)	198-6991 (QTY 42)	196-4404 (QTY 42)	198-6989 (QTY 42)	198-6991 (QTY 42)	198-6991 (QTY 42)	8E-9812 (QTY 40)	6I-9573 (QTY 40)	216-6286 (QTY 40)
		Master Track Shoe	198-6988 (QTY 1)	198-6992 (QTY 1)	196-4405 (QTY 1)	198-6990 (QTY 1)	198-6992 (QTY 1)	198-6992 (QTY 1)	3T-8601 (QTY 2)	3T-8601 (QTY 2)	3T-8601 (QTY 2)
D3	XKW, XKY, XT5	Track Bolt	4K-7038 (QTY 160)	4K-7038 (QTY 160)	4K-7038 (QTY 160)	4K-7038 (QTY 168)	4K-7038 (QTY 168)	4K-7038 (QTY 168)	9G-3110 (QTY 156)	9G-3110 (QTY 156)	9G-3110 (QTY 156)
		Master Track Bolt	5A-3187 (QTY 4)	5A-3187 (QTY 4)	5A-3187 (QTY 4)	5A-3187 (QTY 4)	5A-3187 (QTY 4)	5A-3187 (QTY 4)	9G-8592 (QTY 2)	9G-8592 (QTY 2)	9G-8592 (QTY 2)
		Track Nut	7K-2017 (QTY 160)	7K-2017 (QTY 160)	7K-2017 (QTY 160)	7K-2017 (QTY 168)	7K-2017 (QTY 168)	7K-2017 (QTY 168)	1M-1408 (QTY 156)	1M-1408 (QTY 156)	1M-1408 (QTY 156)
		Track Shoe	198-6987 (QTY 40)	198-6991 (QTY 40)	196-4404 (QTY 40)	198-6989 (QTY 42)	198-6991 (QTY 42)	198-6991 (QTY 42)	8E-9812 (QTY 40)	6I-9573 (QTY 40)	216-6286 (QTY 40)
		Master Track Shoe	198-6988 (QTY 1)	198-6992 (QTY 1)	196-4405 (QTY 1)	198-6990 (QTY 1)	198-6992 (QTY 1)	198-6992 (QTY 1)	3T-8601 (QTY 2)	3T-8601 (QTY 2)	3T-8601 (QTY 2)

UNDERCARRIAGE D1/D2/D3

SMALL DOZERS		Abrasion Undercarriage					
		Rollers (per side)		Sprocket Rings (per side)	Idler (per side)	Idler Assembly (per side)	Link Assembly (per side)
Sales Model	Serial Number Prefix	Single Flange	Carrier				
D1/D2	XKF, XKL, XT3, XKM, XKR	581-3757 (QTY 6)	225-7650	258-9787	578-8007	578-8008	561-1091
D3	XKW, XKY, XT5	357-5368 (QTY 7)	362-0515	258-9788	422-2588	422-2587	561-1082

SMALL DOZERS		Abrasion Track								
		Shoes and Hardware (per side)								
Sales Model	Serial Number Prefix	Description	D1	D1 LGP	D1 LGP (762 MM/30 IN)	D2	D2 LGP	D3	D3 LGP	D3 LGP (762 MM/30 IN)
D1/D2	XKF, XKL, XT3, XKM, XKR	Track Bolt	301-4302 (QTY 148)	301-4302 (QTY 148)	301-4302 (QTY 148)	301-4302 (QTY 148)	301-4302 (QTY 148)	238-0472 (QTY 140)	238-0472 (QTY 140)	238-0472 (QTY 140)
		Master Track Bolt	254-0228 (QTY 4)	254-0228 (QTY 4)	254-0228 (QTY 4)	254-0228 (QTY 4)	254-0228 (QTY 4)	254-0227 (QTY 4)	254-0227 (QTY 4)	254-0227 (QTY 4)
		Track Nut	51-6125 (QTY 148)	51-6125 (QTY 148)	51-6125 (QTY 148)	51-6125 (QTY 148)	51-6125 (QTY 148)	238-0473 (QTY 140)	238-0473 (QTY 140)	238-0473 (QTY 140)
		Track Shoe	235-2559 (QTY 38)	235-2559 (QTY 38)	323-8931 (QTY 37)	243-2693 (QTY 38)	235-2558 (QTY 37)	235-2554 (QTY 36)	235-2555 (QTY 35)	235-2534 (QTY 35)
		Master Track Shoe	–	269-3798 (QTY 1)	372-0547 (QTY 1)	–	263-3798 (QTY 1)	–	260-6762 (QTY 1)	255-4182 (QTY 1)
		Master Track Link	311-6180 (QTY 2)	311-6180 (QTY 2)	311-6180 (QTY 2)	311-6180 (QTY 2)	311-6180 (QTY 2)	318-2486 (QTY 2)	318-2486 (QTY 2)	318-2486 (QTY 2)
D3	XKW, XKY, XT5	Track Bolt	301-4302 (QTY 140)	301-4302 (QTY 140)	301-4302 (QTY 140)	301-4302 (QTY 148)	301-4302 (QTY 148)	238-0472 (QTY 140)	238-0472 (QTY 140)	238-0472 (QTY 140)
		Master Track Bolt	254-0228 (QTY 4)	254-0228 (QTY 4)	254-0228 (QTY 4)	254-0228 (QTY 4)	254-0228 (QTY 4)	254-0227 (QTY 4)	254-0227 (QTY 4)	254-0227 (QTY 4)
		Track Nut	51-6125 (QTY 140)	51-6125 (QTY 140)	51-6125 (QTY 140)	51-6125 (QTY 148)	51-6125 (QTY 148)	238-0473 (QTY 140)	238-0473 (QTY 140)	238-0473 (QTY 140)
		Track Shoe	235-2559 (QTY 36)	235-2559 (QTY 36)	235-2559 (QTY 36)	243-2693 (QTY 38)	235-2558 (QTY 37)	235-2554 (QTY 36)	235-2555 (QTY 35)	235-2534 (QTY 35)
		Master Track Shoe	–	263-3798 (QTY 1)	263-3798 (QTY 1)	–	263-3798 (QTY 1)	–	260-6762 (QTY 1)	255-4182 (QTY 1)
		Master Track Link	311-6180 (QTY 2)	311-6180 (QTY 2)	311-6180 (QTY 2)	311-6180 (QTY 2)	311-6180 (QTY 2)	318-2486 (QTY 2)	318-2486 (QTY 2)	318-2486 (QTY 2)



GROUND ENGAGING TOOLS D1/D2/D3

SMALL DOZERS		Blade									Ripper	
		Cutting Edge Group									Tooth Group	
Sales Model	Serial Number Prefix	Description	D1	D1 LGP	D1 LGP (762 MM/30 IN)	D2	D2 LGP	D3	D3 Forestry	D3 LGP	All	
D1/D2/D3	XKF, XKL, XT3, XKM, XKR, XKW, XKY, XT5	Bolt-Plow	3F-5108 (QTY 18)	3F-5108 (QTY 22)	3F-5108 (QTY 20)	3F-5108 (QTY 18)	3F-5108 B (QTY 22)	5J-4771 (QTY 20)	5J-4771 (QTY 20)	3F-5108 (QTY 22)	Shank-Ripper 1U-1257 (QTY 1)	
		Nut-Full	4K-0367 (QTY 18)	4K-0367 (QTY 22)	4K-0367 (QTY 20)	4K-0367 (QTY 18)	4K-0367 (QTY 22)	2J-3506 (20 PC)	2J-3506 (QTY 20)	4K-0367 (QTY 22)	Cotter 3B-4630 (QTY 2)	
		Washer-Hard	5P-8247 (QTY 18)	5P-8247 (QTY 22)	5P-8247 (QTY 20)	5P-8247 (QTY 18)	5P-8247 (QTY 22)	5P-8248 (20 PC)	5P-8248 (QTY 20)	5P-8247 (QTY 22)	Pin-G.E.T. 3G-6049 (QTY 1)	
		Bit-End Right	462-8032 (QTY 1)	462-8032 (QTY 1)	462-8032 (QTY 1)	462-8032 (QTY 1)	462-8032 (QTY 1)	8E-7079 (1 PC)	8E-7079 (QTY 1)	462-8032 (QTY 1)	Tip-Penetration 9J-4259 (QTY 1)	
		Bit-End Left	462-8033 (QTY 1)	462-8033 (QTY 1)	462-8033 (QTY 1)	462-8033 (QTY 1)	462-8033 (QTY 1)	8E-7078 (1 PC)	8E-7078 (QTY 1)	462-8033 (QTY 1)	Pin-G.E.T. 132-4763 (QTY 1)	
		Edge-Cutting	467-7955 (QTY 2)	467-7956 (QTY 2)	467-7957 (QTY 2)	462-8030 (QTY 2)	467-7956 (QTY 2)	331-0162 (2 PC)	331-0162 (QTY 2)	462-8034 (QTY 2)	Retainer Assembly 149-5733 (QTY 1)	
		Alternate Flat Endbits	4T-6229 (QTY 2) -or- 195-7193 (QTY 2)	4T-6229 (QTY 2) -or- 195-7193 (QTY 2)	4T-6229 (QTY 2) -or- 195-7193 (QTY 2)	4T-6229 (QTY 2) -or- 195-7193 (QTY 2)	4T-6229 (QTY 2) -or- 195-7193 (QTY 2)	-	-	-	-	
		Extended Wear Life	Cutting Edge	472-4116	472-4122	472-4120	472-4118	472-4122	-	-	472-4119	-
			End Bit Right	472-4112	472-4112	472-4112	472-4112	472-4112	-	-	472-4112	-
			End Bit Left	472-4113	472-4113	472-4113	472-4113	72-4113	-	-	472-4113	-

ENGINE PARTS D1/D2/D3

Sales Model	Serial Number Prefix	Alternator	Starter	Water Pump	Turbo	Electric Fuel Pump and Filter	High Pressure Fuel Pump	Fuel Injector
D1/D2/D3	XKF, XKL, XT3, XKM, XKR, XKW, XKY, XT5	515-4364	321-8965	533-5882	572-6424	551-2110	553-8165	553-8167

DIESEL EXHAUST FLUID D1/D2/D3

Cat Part Number (32.5% UREA)	Container Size
350-8733	9.46 L (2.5 gal) bottle
350-8734	1,000 L (264 gal) tote

LIGHTS D1/D2/D3

Sales Model	Serial Number Prefix	6 Lights	6 Lights LED
D1/D2/D3	XKF, XKL, XT3, XKM, XKR, XKW, XKY, XT5	Front: 214-2969 (QTY 4) Rear: 214-2968 (QTY 2)	Front: 589-0464 (QTY 4) Rear: 589-0462 (QTY 2)
		Front & rear bulb: 9W-0607 Front lens: 202-6611 Rear lens: 202-6614	

BATTERIES D1/D2/D3

Sales Model	Serial Number Prefix	Battery
D1/D2/D3	XKF, XKL, XT3, XKM, XKR, XKW, XKY, XT5	115-2422 (QTY 2)

SEAT BELT D1/D2/D3

Sales Model	Serial Number Prefix	Seat Belt
D1/D2/D3	XKF, XKL, XT3, XKM, XKR, XKW, XKY, XT5	545-9384

CAB GLASS D1/D2/D3

Sales Model	Serial Number Prefix	Glass Left Door	Glass Right Door	Glass Front	Glass Rear	Left Window GP	Right Window GP	Poly Left Door	Poly Right Door	Poly Front
D1/D2/D3	XKF, XKL, XT3, XKM, XKR, XKW, XKY, XT5	343-3556	343-3555	343-3552	343-3551	393-4585	393-4580	514-6775	514-6774	514-6773

WIPERS D1/D2/D3

Sales Model	Serial Number Prefix	Door	Front	Rear
D1/D2/D3	XKF, XKL, XT3, XKM, XKR, XKW, XKY, XT5	125-8175	5C-8811	146-6433



LINKAGE PIN AND BEARING PART NUMBERS D1/D2/D3

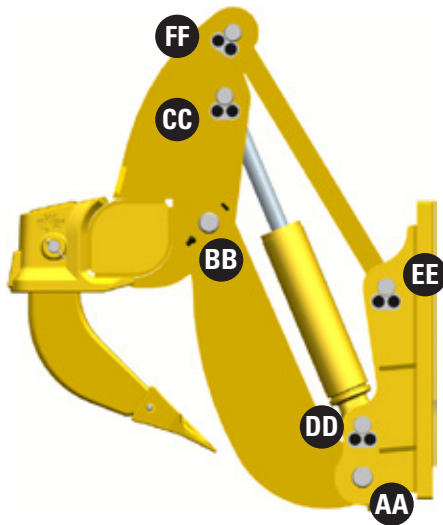

		Parallelogram Ripper Linkage		
Sales Model	Serial Number Prefix	AA	BB	CC
D1/D2/D3	XKF, XKL, XT3, XKM, XKR, XKW, XKY, XT5	7p-2358 - Pin (QTY 2)	8J-7008 - Pin (QTY 2)	397-0242 - Pin (QTY 2) 7K-6365 - Bearing Sleeve (QTY 2)

		Parallelogram Ripper Linkage		
Sales Model	Serial Number Prefix	DD	EE	FF
D1/D2/D3	XKF, XKL, XT3, XKM, XKR, XKW, XKY, XT5	397-0241 - Pin (QTY 2) 7K-6365 - Bearing Sleeve (QTY 2)	397-0241 - Pin (QTY 2)	397-0242 - Pin (QTY 2)

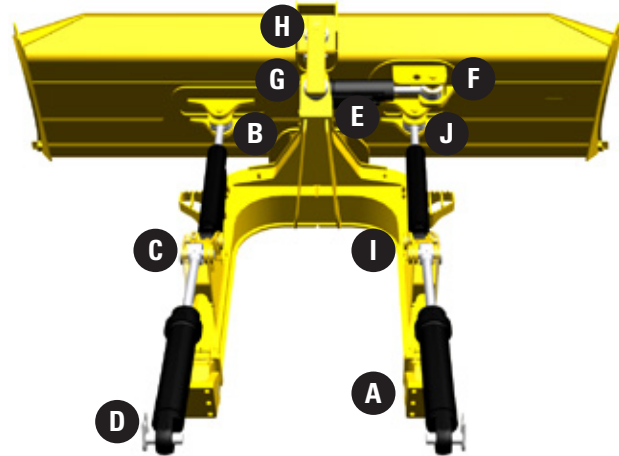
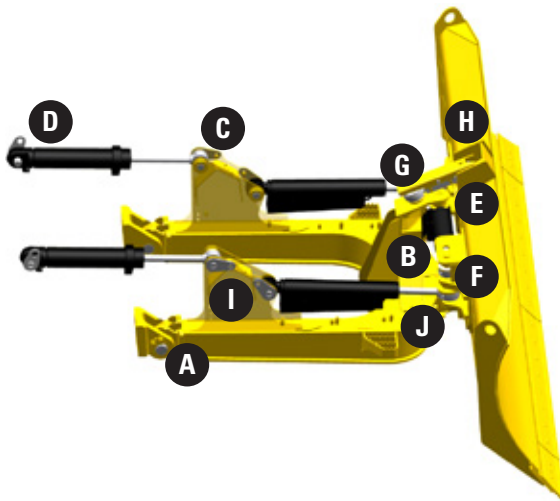

		Angling Blade System				
Sales Model	Serial Number Prefix	A	B	C	D	E
D1/D2/D3	XKF, XKL, XT3, XKM, XKR, XKW, XKY, XT5	461-4319 - Pin (QTY 2) 183-1176 - Bearing (QTY 2)	179-5757 - Trunnion 179-5755 - Bearing Cap (QTY 2)	461-4320 - Pin (QTY 2) 263-3181 - Bushing (QTY 2)	397-0234 - Pin (QTY 2) 263-3181 - Bushing (QTY 2)	8J-0928 - Pin 9J-9812 - Bearing 2H-5549 - Retainer Ring 471-6399 - Spacer

		Angling Blade System				
Sales Model	Serial Number Prefix	F	G	H	I	J
D1/D2/D3	XKF, XKL, XT3, XKM, XKR, XKW, XKY, XT5	6Y-1421 - Pin 4D-0298 - Bearing 1L-4775 - Retainer Ring 471-6399 - Spacer	4D-4431 - Bearing 2H-5549 - Retainer Ring	4D-4431 - Bearing 2H-5549 - Retainer Ring	461-4320 - Pin (QTY 2) 4D-0298 - Bearing (QTY 2) 1L-4775 - Retainer Ring (QTY 2)	6Y-1421 - Pin (QTY 2) 9J-9812 - Bearing (QTY 2) 2H-5549 - Retainer Ring (QTY 2) 471-6400 - Spacer (QTY 2)

LET'S DO THE WORK.™

PEBJ0175
November 2020
(Global)

© 2020 Caterpillar. All Rights Reserved. CAT, CATERPILLAR, LET'S DO THE WORK, their respective logos, "Caterpillar Corporate Yellow," the "Power Edge" and Cat "Modern Hex" trade dress, as well as corporate and product identity used herein, are trademarks of Caterpillar and may not be used without permission.

