

# Generac



## Generac MF900 heats up the competition

If you were to visit a jobsite in a cold, wintry climate, chances are you would see workers using one or more mobile heaters. These types of heaters are used for many commercial applications in order to keep jobsites warm and operational – even in the most extreme cold-weather environments. And if you start to look around, you'll see that Generac heaters are being used at many of these sites, keeping workers warm and productive.

### The heat is on...

Located in Waukesha, WI, Generac Mobile group develops mobile heaters and other types of mobile equipment and solutions that are durable, reliable, safe and easy to use. Many of these offerings feature integrated Perkins products to ensure reliable operation whenever and wherever it is needed.

Generac manufactures one of the widest ranges of power products in the marketplace, including portable, residential, commercial and industrial generators. It is also a leading designer and manufacturer of manual and fully automatic transfer switches and accessories for backup power applications up to 2 MW. Generac products are designed and built for the most demanding environments: engineering, procurement, construction, oil and gas, airlines, outdoor events and disaster-relief applications.

### Key Facts

Customer  
**Generac**

Location  
**Waukesha, WI, U.S.**

Engine model  
**Perkins® 1204F-E44TTA**

Application  
**Flameless heater**

OEM website  
**[generacmobileproducts.com](http://generacmobileproducts.com)**

Recently, Generac set out to improve its line of jobsite heaters by redesigning several models and introducing the new MFH900 mobile flameless heater. The flameless heaters are purpose-designed to provide heat in environments where an open flame could be hazardous. The flameless technology utilises a hydraulic pump circuit to load a diesel engine, which generates heat. To generate the maximum amount of heat, the system also uses heat from other sources including the engine, the radiator and the exhaust system. Taking input from the field and several customer and worksite visits, the new design also offers enhanced safety, serviceability and ease-of-use features.

### ... and it's powered by Perkins

Generac ultimately chose the Perkins® 1204F-E44TTA for the new flameless heater which focuses almost exclusively on oil and gas and mining applications. The engine meets the latest U.S. EPA Tier 4 Final emissions standards and features an innovative, compact design that allows it to be integrated into the heater with minimal re-engineering. The 1204F is ideal for a myriad of rental-equipment applications and is also used for construction, agriculture, emergency thawing and pipeline projects.

“We selected the Perkins® 1204F because it met our system requirements and was able to perform at the required load to meet our customers’ demands,” says Jeff Pano, engineer II

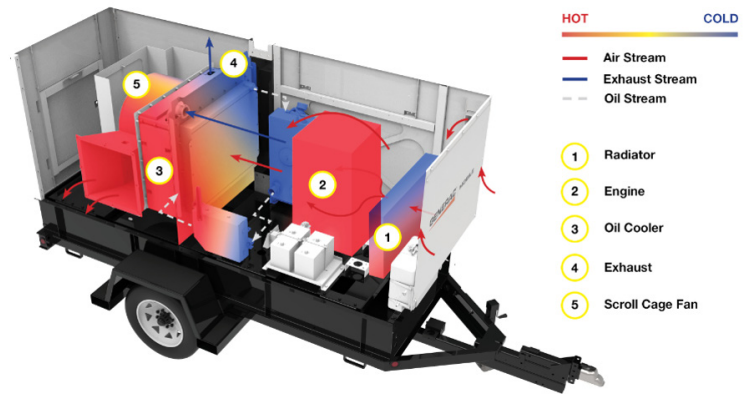

at Generac. “We also appreciate the fact that Perkins provided a high level of support throughout the development process. They worked onsite with us to get our engine qualified, ensured the engine and system controller were communicating properly, and helped us introduce the heaters to our customers.”

By specifying and integrating the new engine with the help of Perkins, Generac was able to meet its objectives of producing up to 875K BTU/HR on each heater’s highest setting and down to 600K BTU/HR at the lowest heat setting. The Perkins engine also meets customers’ requirements for fuel economy – it has a minimum run time of 26 hours on one fuel and DEF (diesel exhaust fluid) fill at 92 percent efficiency.

The MFH900 Flameless Heaters provide **safe and reliable heat for oil and gas, mining, construction, utility projects and more.** Engineered with safety in mind, each heater features a comprehensive set of alarms and shutdowns for emergency situations, as well as a lockable cabinet to prevent tampering.

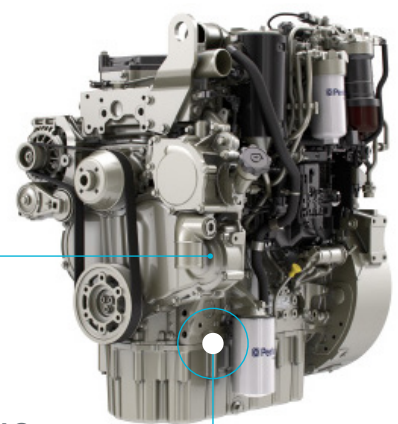

Powered by a Perkins® 1204F-E44TTA engine which features an innovative, compact design allowing integration with minimal re-engineering