

Image shown may not reflect actual configuration.

Combined Heat and Power Enclosure with G3520H Generator Set

These sound attenuated, factory installed enclosures are designed for safety and combined heat and power optimization. Rugged construction provides weather protection and the ability to withstand exposure to the elements.

Features and Benefits

Robust/Highly Corrosion-Resistant Construction

- Combined hot water and power generation
- Weather proof Caterpillar white enclosure
- Zinc plated or stainless steel fasteners
- 22-gauge galvanized steel construction
- Pitched roof for improved rain ingress protection
- Internally mounted overhead crane w/ trolley for easy maintenance
- Externally mounted exhaust system (muffler and heat exchanger)
- 75 dBA enclosure at 7 m
- Vibration spring isolators
- Roof mounted cooling system
- 120 MPH wind load
- Motorized dampers
- Integrated crankcase ventilation system (CCV)
- Integrated gas fuel train NFPA37 & CSAB149.3 with external fuel connections
- Oil makeup tank (50 gallon), Waste oil tank (300 gal / 2 oil changes), Fresh oil tank (500 gal / 2 oil changes + makeup)
- Interior AC lighting system and receptacles
- Optional: Cold-weather bundle including enclosure heaters and ventilation recirculation
- Optional: Oxidation catalyst

Controls

- Cat Switchgear master control panel
 - 19" color touchscreen
 - EMCP 4.3 genset controller
 - Multi-function protective relay
 - 15kV generator breaker
 - Synchronization and utility paralleling control
 - Balance of Plant and CHP controller
- Modbus TCP interface for customer SCADA
- Cat Connect Enabled
- Requires customer provided 480V, 3ph, 150A shore power

Security and Safety

- Lockable access doors with standard key use
- Separate electrical control room
- Cooling fan and battery charging alternator fully guarded
- Oil fill and battery access inside enclosure only
- Externally mounted emergency stop button
- Designed for spreader-bar lifting to ensure safety
- Gas leak alarm
- Fire detection system
- Spill containment floor
- Four E-stop buttons at convenient locations
- Emergency lighting
- Optional: Fire suppression system
- Optional: Interior DC lighting system with automatic shutoff timer

Excellent Access

- Walk-in enclosure allows sufficient access for operators and technicians
- Cable stub up is easily accessible through the floor and wall access panel
- Double doors on both sides
- Batteries recessed in base to improve maintenance access to the engine

Certifications

- NSPS Factory Compliant
- UL2200 Compliant
- CSA / TSSA
- Tested and analyzed in accordance with ASCE 7

	100% GROSS POWER	75% GROSS POWER	50% GROSS POWER	
POWER	Ambient Temperature	77°F	77°F	77°F
	CHP Fuel Input (MMBtu per hour LHV)	19.4	15.1	10.7
	Gross Electricity Output (kW)	2480	1880	1280
	Net Electricity Output (kW)	2400	1800	1200
	Net Electric Efficiency % (LHV)	42.4%	41.0%	38.0%

HOT WATER		
Supply Temp to Site (°F)		210
HW flow (GPM)		361
Return Temp from Site (°F)		160
Hot Water Capacity (MMBtu/hr)		8.40
Thermal Efficiency % (LHV)		42.3%
CHP Fuel Use Eff % (Hot Water Operation)		84.7%

Notes:

- 1) Based off EM3821-00
- 2) Calculated using ISO 3046/1 Genset fuel consumption

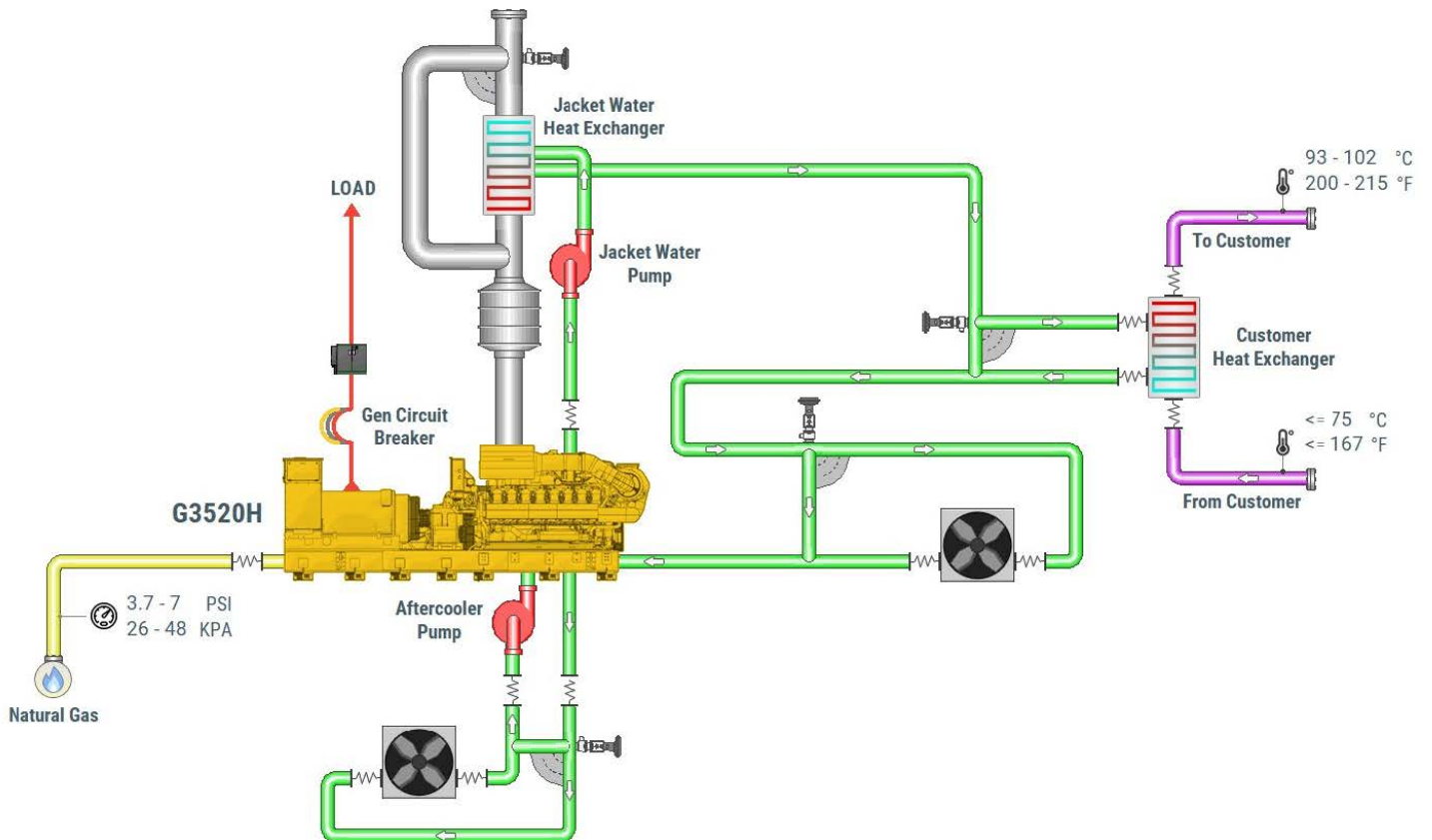

Enclosure Weights and Dimensions

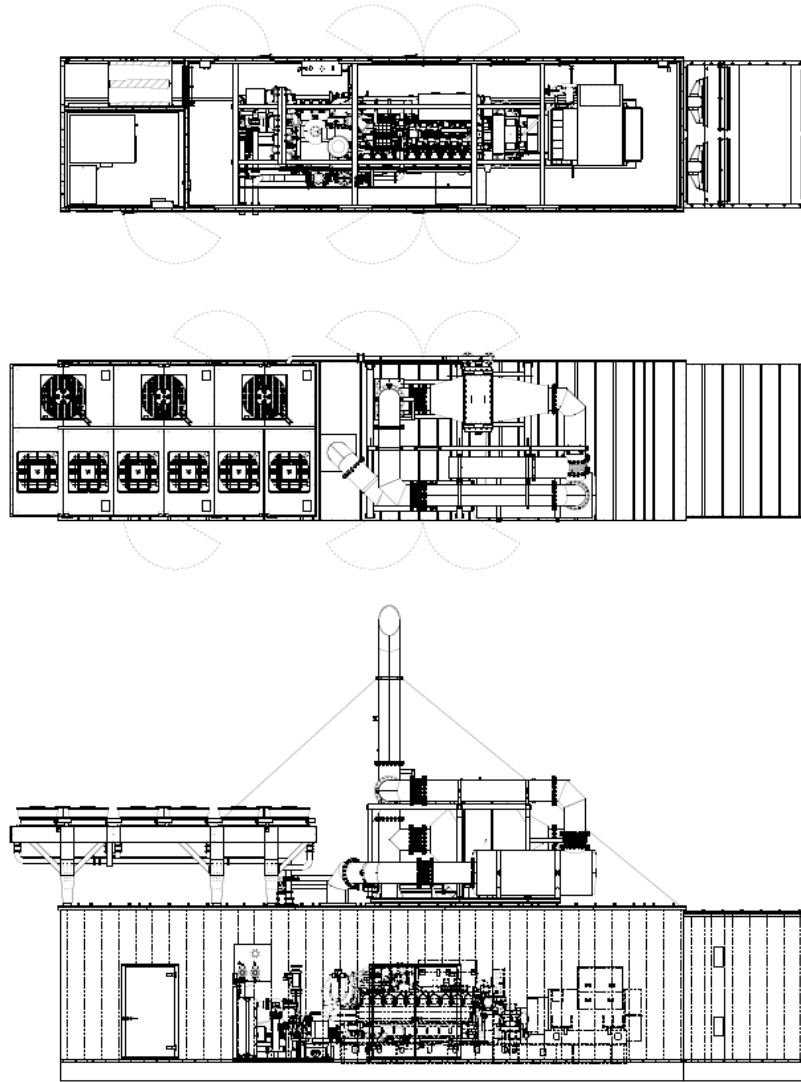

SYSTEM / COMPONENT	LENGTH	WIDTH	HEIGHT	WEIGHT
Enclosure	14.83m (48.75')	3.66m (12')	4.24m (13.91')	61,000 kg (134,500 lbs)
Air Intake Skid	2.95m (9.75')	3.51m (11.5')	4.09m (13.41')	6,400 kg (14,100 lbs)
Exhaust Skid	6.40m (21')	3.99m (13.08')	7.07m (23.20')	5,513 kg (11,700 lbs)
Radiator Skid	7.29m (23.92')	3.66m (12')	2.30m (7.55')	3,500 kg (7,700 lbs)
Installed Dimensions	19.06m (759.5")	3.65m (144")	11.34m (446.7")	76,200 kg (168,000 lbs)

Note: For reference only – not for installation design. Please contact your dealer for exact weights and dimensions

<http://www.cat.com/chp>

Materials and specifications are subject to change without notice.
The International System of Units (SI) is used in this publication.

© 2021 Caterpillar. All Rights Reserved.

CAT, CATERPILLAR, LET'S DO THE WORK, their respective logos, "Caterpillar Corporate Yellow", the "Power Edge" and Cat "Modern Hex" trade dress as well as corporate and product identity used herein, are trademarks of Caterpillar and may not be used without permission.