



ALL THE RIGHT CHOICES CAT[®] MINING UNDERCARRIAGE

**OPTIONS TO MATCH YOUR APPLICATION
AND UNDERFOOT CONDITIONS**



HYDRAULIC MINING SHOVELS, ELECTRIC ROPE SHOVELS
AND ROTARY DRILLS



LOWER COST. LONGER LIFE.

GENUINE CAT BRANDED UNDERCARRIAGE IS NEVER MANUFACTURED BY A COMPETITOR.

Undercarriage represents an average 50% of your machine's owning and operating costs, so it makes sense to invest in a system that will deliver the most value. With 117 years of undercarriage innovation, we're dedicated to giving you the best products—and we never stop working to make them better.

Every Cat® Undercarriage is designed by Caterpillar engineers and built to exacting specifications based on businesses just like yours. We use on-board technology like load analysis to develop better products that match your machine and your applications – and lower your costs.

Caterpillar designs and manufactures all of our mining undercarriage products. You won't find genuine Cat branded undercarriage anywhere else.

LET'S DO THE WORK.™

CAT MINING UNDERCARRIAGE

DELIVERING LONGER WEAR LIFE AND LOWER COST PER HOUR
SO YOU CAN MOVE MORE MATERIAL, MORE EFFICIENTLY.

All Cat Undercarriage components are integrated with the machine and designed to work as a system. Caterpillar product support, warranty, undercarriage assurance programs, and worldwide parts distribution network ensure responsive service and long life.



CONVENTIONAL 6015-6020



SHOVEL STYLE 6030-6090



**SHOVEL STYLE
7295-7495**



**CONVENTIONAL
ALL TRACK AND ROTARY**

HYDRAULIC MINING SHOVELS

Experience increased uptime and low operating costs with Cat Undercarriage designed and built specifically to withstand the rigors of any digging environment.

- Heavier track chain handles high field loads
- Heavy duty rollers and idlers increase reliability
- Reduced pitch extension wear increases track chain life by 20% to 40%

ELECTRIC ROPE SHOVELS

Keep productivity up with undercarriage designed and built specifically for your challenging conditions.

- Larger diameter idler reduces contact stress with the track link
- Larger track roller shaft increases roller durability and life
- Larger track roller tread reduces contact stress with track

ROTARY DRILLS

Your rotary drill just got a new lease on life. Cat Grease Lubricated Track (GLT) Undercarriage is built for the rigorous conditions in mining applications.

- Larger undercarriage components, stronger assemblies, and 25% increase in internal wear
- All components are designed for extreme conditions and to increase undercarriage life

HYDRAULIC MINING SHOVEL, ELECTRIC ROPE SHOVEL AND ROTARY DRILL UNDERCARRIAGE

NEW OFFERINGS ARE AVAILABLE TO REPLACE EXISTING UNDERCARRIAGE ON OLDER MACHINES WITH GENUINE CAT UNDERCARRIAGE

CAT TRACK OPTIONS	ROTARY DRILL CAPABILITY				
	MD6290/ SKR	MD6240/ SKFX	MD6420A/ SKS	MD6540/ SKL	MD6640/ 49HR
GLT (GREASED LUBRICATED TRACK)	•	•			
GLT WITH PPR2 (POSITIVE PIN RETENTION 2)			•	•	•
	TRACK DRILL CAPABILITY				
	MD5075/ R30C	MD5090 345-345S	MD5125SCH/ 5000C/CL	MD5150/ R60	
GLT (GREASED LUBRICATED TRACK)	•	•	•	•	
	HYDRAULIC MINING SHOVEL CAPABILITY				
	6015	6020			
GLT WITH PPR2 (POSITIVE PIN RETENTION 2)	•	•			
	HYDRAULIC MINING SHOVEL CAPABILITY				
	6030	6040	6050	6060	6090
CAT HEAVY DUTY UNDERCARRIAGE	•	•	•	•	•
	ELECTRIC ROPE SHOVEL CAPABILITY				
	7495HR	7495HD	7495HF		
CAT UNDERCARRIAGE	•	•	•		

YOUR ON-THE-JOB PARTNER

You've invested time, money and sweat building your business. Your local Cat dealer can help you make the most of your equipment investment. With a team of experts on-site and online, they have the products, service and advice to keep you working.

Our parts and service representatives:

- Have the best training and tools to manage your undercarriage system
- Regularly inspect and measure wear on your undercarriage
- Prepare reports with maintenance and repair alternatives so you can make informed decisions to reach the lowest possible cost-per-hour or per mile/km of operation

MINING OUR FUTURE

We are serious about your business and your Cat equipment. Based on your input, we are working on a multi-generational mining product development plan, dedicated to creating mine-site solutions that will keep your machines running longer and working harder. Our goal is to offer you the lowest owning and operating costs with the strongest and most reliable power in the industry.



ROTARY DRILLS

DESIGNED TO INCREASE UNDERCARRIAGE AND COMPONENT LIFE

- Heavier track chain increases durability for handling high field loads
- GLT reduces pitch extension wear for 20-40% increased chain life
- Larger diameter idler and larger track roller tread reduce contact stress with track link
- Double flange rollers improve primary track guiding
- Stronger, welded roller guard assembly improves secondary track guiding



CAT GREASE LUBRICATED TRACK

IMPROVE UNDERCARRIAGE LIFE ON YOUR EXCAVATORS

Each track joint is sealed to retain the grease added between the pin and bushing, minimizing internal wear by at least 25% over sealed track. Grease Lubricated Track link assemblies are direct replacements for sealed link assemblies on Cat hydraulic excavator models.

- Increases external wear life by at least 20% with larger bushing
- Decreases track noise by eliminating metal-to-metal contact between pin and bushing
- Improves sprocket wear life with sprocket and link assembly pitch remaining matched for a longer period of operation
- Allows for enhanced undercarriage management opportunities

With sealed track, internal pin and bushing wear begins immediately because of contact and friction between the two parts. Grease Lubricated Track contains grease between the pin and bushing to eliminate the contact and friction wear elements, resulting in a significant increase of internal wear life of the link assembly.

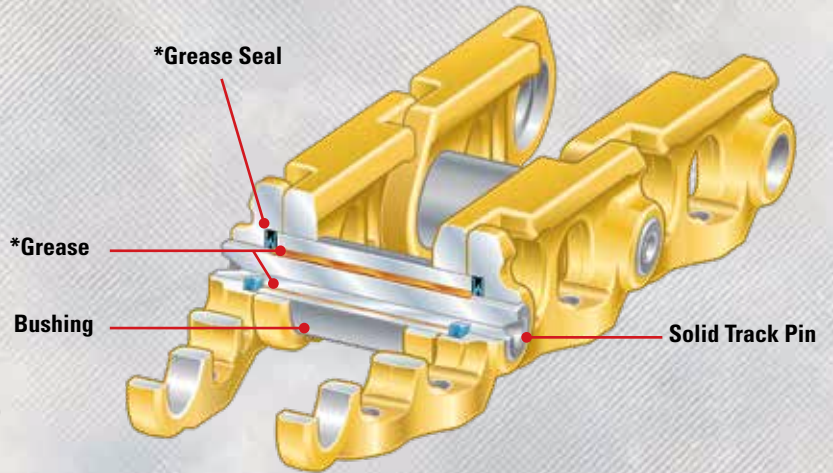

* Models MD5050-MD6240 use the Poly-W track seal as shown. Models MD6240-MD6640 use a rigid track seal.

POSITIVE PIN RETENTION 2 (PPR2) TRACK

EXCLUSIVE DESIGN EXTENDS TRACK LIFE AND COMPONENT REUSE

PPR2 was designed for high-impact and high-travel applications such as mining, heavy construction, pipe laying, demolition, and scrap handling. It mechanically locks the link to the pin to resist pin walking and link cracking for reliable sealing and maximum track life to minimize your owning and operating costs.

- Resists end-play generation and link movement on the pin
- Tightly controls seal motion for long internal pin/bushing wear life
- Resists fatigue and crack formation with redesigned, stronger track links

Standard on MD6420A, 6015, 6020B, 374D, and 390D.

Any application with high impact and/or travel rates will apply high loading and twisting forces into the track chain. That's when you need PPR2 most. PPR2 should also be considered for machines equipped with wide or single grouser shoes.

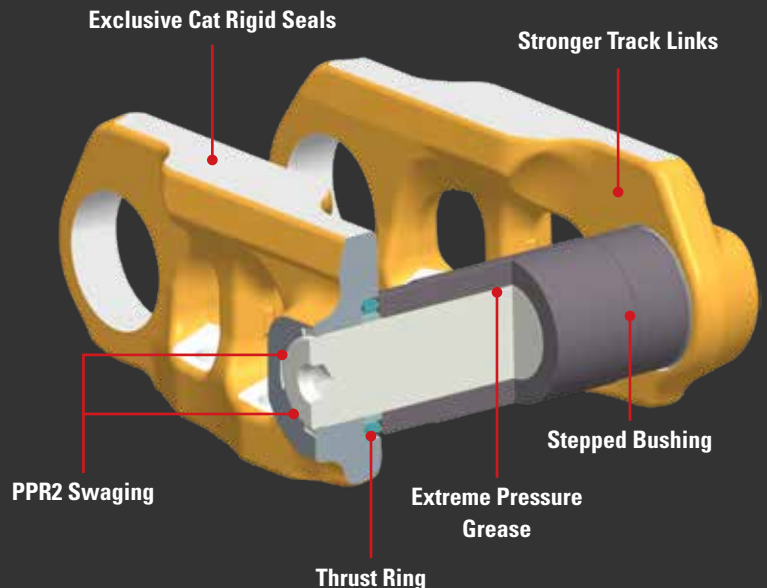

HYDRAULIC MINING SHOVEL (HMS)

6015 AND 6020 TRACK GROUP/LINK ASSEMBLY

- Designed with industry-leading technology
- Grease Lubricated Track (GLT) with exclusive Cat rigid seals
- Positive Pin Retention—PPR for the 6015B and PPR2 for the 6015/6020B
- Extra material in links with spalling-resistant design
- Stepped bushings

TRACK ROLLERS

Designed with industry-leading technology

- Sealed-for-life track rollers
- Heavy duty components

IDLER GROUP

Designed with industry-leading technology

- Hydraulic tension control
- Cat duo-cone seals
- Sealed-for-life idler

SPROCKETS

- Life matched to rest of undercarriage system
- Alloy steel casting with selective heat treat to maximize life



6030, 6040, 6050, 6060, AND 6090 TRACK PADS

Designed for long wear life and maximum protection against breakage

- Cast pads from high-quality steel: alloy steel, case-hardened bushings
- Induction hardened roller paths and drive lugs for long wear life and tough interior
- High interference, straight bushings for longer joint life (6030-6090)
- Cat service tooling; can be easily re-pinned and re-bushed
- Proprietary heat treat and quench system

PINS

- Spring clip pin retention and nut and bolt retention keep pins from walking
- Larger pin bosses and improved pin retention to maximize life
- Improved pin retention
- Can be re-bushed

SPROCKETS

- Life matched to rest of undercarriage system
- Alloy steel casting with selective heat treat to maximize life

ROLLERS/IDLERS

- Caterpillar proprietary fixed axle technology to limit overheating
- Sealed-for-life with Cat seal system and oil lubrication to eliminate grease consumption for improved life and performance
- One-piece forged roller rim to improve structural integrity
- Simple bolt-on assembly

ELECTRIC ROPE SHOVEL (ERS)

TRACK PADS

- Through hardened; optimum ductility and yield strength
- Designed for long wear life and maximum protection against breakage

PINS

- Alloy pins eliminate stress risers
- Simple, easy-to-service pin retention method
- Induction hardened, alloy steel—no stress riser at shoulder

SPROCKETS/TUMBLERS

- Highly tolerant of pitch extension
- Raised to provide optimum clearance of ground objects
- Self-seeking pitch line allows spreading load over several teeth
- Designed to last life of track pads with minimal maintenance
- Alloy steel casting with heat treat to maximize life

IDLERS

- Greased lubrication eliminates catastrophic failures associated with seal failure and oil leakage
- Simple track tension adjustment system



DEALER UNDERCARRIAGE ASSURANCE PROGRAMS

UNDERCARRIAGE ASSURANCE PROGRAMS

To help you get the most from your Cat Undercarriage, your Cat dealer will make sure you have global service and support for all undercarriage configuration options, from advanced diagnostics to worldwide parts delivery.

Our Undercarriage Assurance Programs provide the lowest cost-per-hour undercarriage systems with support beyond the standard new machine or parts warranties. They cover all major moving undercarriage components on Cat Track-Type Tractors. Your Cat dealer has full details about coverage for specific undercarriage configuration options.

DETAILS

ELECTRIC ROPE SHOVEL CAST CRAWLER SHOE ASSURANCE PROGRAM

Caterpillar offers a wear and breakage program developed specifically for the 125-inch cast crawler shoe in oil sands application. The coverage begins at the same time as the standard machine warranty or new parts warranty term and terminates in 4 years or 24,000 hours, whichever occurs first.

ELECTRIC ROPE SHOVEL CAST CRAWLER SHOE ASSURANCE PROGRAM

Caterpillar offers a wear and breakage program developed specifically for the: 1) 79-inch cast crawler shoe used on the 7495 HR AND 2) 84-inch cast crawler shoe used on the 7495 HD. The coverage begins at the same time as the standard machine warranty or new parts warranty term and terminates in 4 years or 20,000 hours, whichever occurs first.

HYDRAULIC MINING SHOVEL CAST CRAWLER SHOE ASSURANCE PROGRAM

Caterpillar offers a wear and breakage program developed specifically for the HD cast crawler shoes used on 6015B-6090. The coverage begins at the same time as the standard machine warranty or new parts warranty term and terminates in 3 years or 15,000 hours, whichever occurs first.

COMPREHENSIVE SUPPORT

To help you get the most from your Cat Undercarriage, Caterpillar and Cat dealers are dedicated to providing you with global service and support for all undercarriage configuration options—from advanced diagnostics to worldwide parts delivery.

UNDERCARRIAGE ASSURANCE PROGRAMS

Our Undercarriage Assurance Programs were developed to demonstrate our commitment to provide you the lowest cost-per-hour undercarriage systems. Assurance Programs offer you support beyond the standard new machine or parts warranties. They cover all major moving undercarriage components on Cat Track-Type Tractors, Track-Type Loaders and Track-Type Hydraulic Excavators. See your Cat dealer for full details about coverage for specific undercarriage configuration options.

CUSTOM TRACK SERVICE (CTS)

An improperly managed undercarriage can cause downtime and account for more than half of machine maintenance costs. That's why we use the most advanced diagnostic equipment available to provide Custom Track Service (CTS) for maintaining your undercarriage system.

With CTS, we can accurately monitor undercarriage performance and predict wear rates so you can evaluate service options, plan maintenance, and fit downtime into your schedule. And because CTS analysis can be completed on the job site, you can make informed decisions that keep your operating costs as low as possible, without sacrificing uptime.

WORLDWIDE PARTS AVAILABILITY

Our industry-standard parts distribution network makes most new parts available to you anywhere in the world, usually within 24 hours.

CONSULT WITH YOUR CAT DEALER TODAY

Your Cat dealer has the undercarriage expertise and selection tools to help you make the best decisions for your machine, application, and owning and operating needs.





INSIST ON CAT UNDERCARRIAGE

Keep your machines running so they can keep adding to your bottom line. Get the lowest owning and operating costs and maximize equipment uptime with genuine Cat undercarriage systems that precisely match your machine and application. Your local dealer has the knowledge and selection tools to help you choose the best option for your operation. Rugged, oversized components and excellent serviceability, plus unmatched support from the global Cat dealer network, keep you working.



PEDJ0200-04

© 2020 Caterpillar. All Rights Reserved. CAT, CATERPILLAR, LET'S DO THE WORK, their respective logos, "Caterpillar Corporate Yellow", the "Power Edge" and Cat "Modern Hex" trade dress as well as corporate and product identity used herein, are trademarks of Caterpillar and may not be used without permission.