

CAT[®] ABRASION[™] UNDERCARRIAGE

INDUSTRY LEADER IN
LOWEST COST PER HOUR



DIFFERENT BY DESIGN

YOU PUSH THROUGH SOME OF THE MOST **ABRASIVE MATERIALS**. THAT'S WHY WE'VE DESIGNED A NEW UNDERCARRIAGE THAT CAN TAKE ON ABRASIVE APPLICATIONS WITH INDUSTRY-LEADING LOW COST-PER-HOUR PERFORMANCE.

MATERIAL APPLICATIONS



SAND



MUD



CLAY



GRAVEL



Up to 50% longer life compared to conventional undercarriage*



Double the seal life** in field follow tests



Industry-best undercarriage assurance up to 6,000 hours on all components

*Compared to Cat Heavy Duty Extended Life (HDXL) undercarriage.
**See field test results page.



KEY BENEFITS

Cat® Abrasion™ is built on proven Cat Rotating Bushing technology that extends undercarriage wear life. Combined with an advanced proprietary cartridge design that dramatically improves sealability, Cat Abrasion delivers the lowest cost per hour in high-abrasion, low-to-medium impact applications.

LESS MAINTENANCE

Eliminates the need for bushing turns in abrasive applications

A

B

LOWER COSTS

Better sealability means less maintenance and reduced costs over the lifecycle

EXTENDED WEAR LIFE

Patented relieved tread idler design extends life up to 2x longer compared to traditional idlers

C

D

SMOOTHER RIDE

Eliminates contact between idlers and link rails providing a smoother ride for operators

INNOVATIVE IMPROVEMENTS

IMPROVED SEALABILITY COMBINED WITH THE PROVEN WEAR LIFE OF ROTATING BUSHING TECHNOLOGY MEANS CAT ABRASION NEEDS LESS TIME FOR MAINTENANCE AND COSTS LESS TO OPERATE.

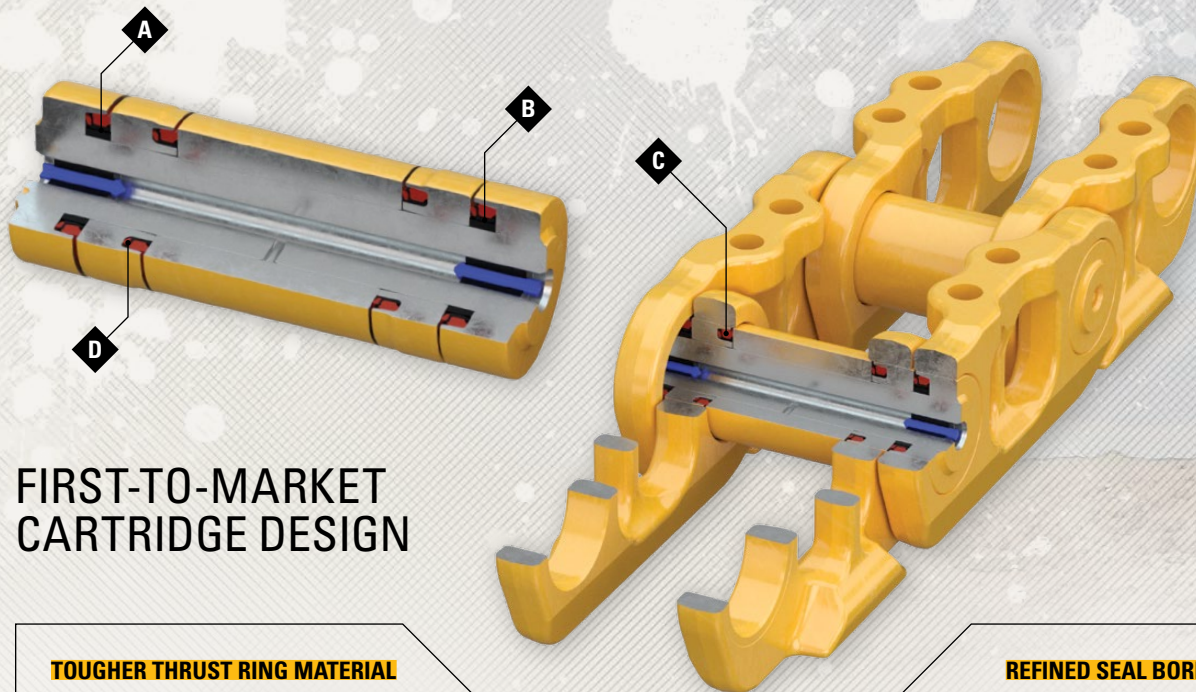

FIRST-TO-MARKET CARTRIDGE DESIGN

TOUGHER THRUST RING MATERIAL

Resists chipping and cracking

A

REFINED SEAL BORE GEOMETRY

Improves seal life in the harshest conditions

B

NEW TRACK SEAL & LOAD RING DESIGN

Reduces packing and oil loss in freeze/thaw conditions

C

NEW EXTENDED LIFE (XL) COATING

Reduces end grooving, corrosion and seal lip wear

D

CURRENT AVAILABILITY: D3-D6 DOZER MODELS*



*Direct replacement for SystemOne, retiring 2020.



STRONG SUPPORT FOR YOUR BOTTOM LINE

Your Cat dealer can help you manage your undercarriage for longer wear life and lower operating costs. Here's how:

CATERPILLAR UNDERCARRIAGE ASSURANCE (UA) PROGRAM

Cat Abrasion offers leakage and breakage coverage for 4 years/6,000 hours, or 100% worn, whichever comes first.

CUSTOM TRACK SERVICE (CTS) UNDERCARRIAGE MANAGEMENT

Used by dealer undercarriage specialists, CTS offers customers an efficient inspection process for measuring and managing wear components, identifying equipment issues, predicting undercarriage wear-out timing and calculating cost per hour.

PARTS COMPATIBILITY WITH SYSTEMONE™

Parts are 100% interchangeable between Cat Abrasion and SystemOne™ undercarriage. The only part number changes will be for the link assembly and track group.

FIELD TESTED. FIELD PROVEN.

CAT ABRASION HAS BEEN EXTENSIVELY TESTED AND PROVEN IN THE CATERPILLAR FIELD FOLLOW PROGRAM. THREE NORTH AMERICAN DEALERS TESTED EARLY IRON AND FOUND THAT CAT ABRASION HAS **DOUBLE THE SEAL LIFE** OF SYSTEMONE IN SIDE-BY-SIDE TESTS.

WEAR LIFE TESTS

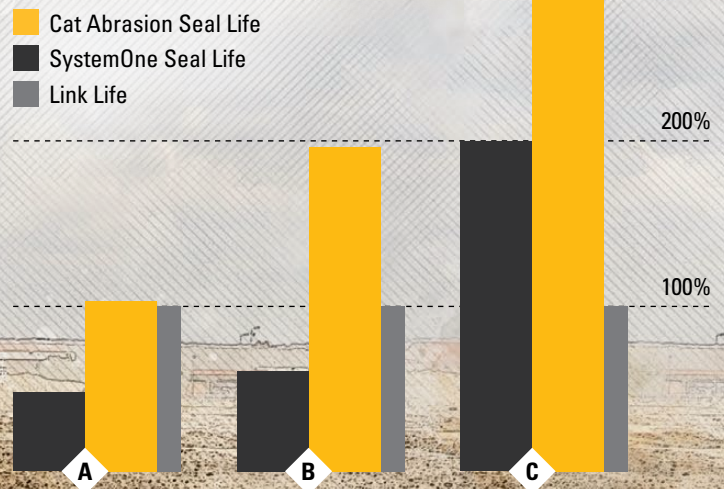

SITE PREP

Clay with a high percentage of sand

A

FINISH GRADING ON SLOPES

Clay with a low percentage of sand

B

ROAD CONSTRUCTION

High percentage of sand

C

CAT UNDERCARRIAGE: A LINEUP OF TOP PERFORMERS

Cat Abrasion is the newest addition to the Cat undercarriage portfolio. Each undercarriage is designed to meet specific application and machine requirements and deliver the industry's lowest cost per hour.

WHERE IT SHOULD WORK

TYPE OF JOB

HOW IT IS MANUFACTURED*

TYPE OF MAINTENANCE

ABILITY TO REBUILD OR REUSE

	GENERAL DUTY	HEAVY-DUTY EXTENDED LIFE (HDXL)	CAT ABRASION
WHERE IT SHOULD WORK	General, light-duty applications with low-to-moderate impact conditions	All applications, including Forestry and Waste, needing production in medium-to-high impact conditions	Applications with high abrasion and low-to-moderate impact conditions
TYPE OF JOB	Utility	Production	Production
HOW IT IS MANUFACTURED*	Cat specifications met within relaxed tolerances	Cat specifications met within tight tolerances	Cat specifications met within tight tolerances
TYPE OF MAINTENANCE	Bushing turn capable, not guaranteed	Bushing turn, wet turn guaranteed	Not required due to design
ABILITY TO REBUILD OR REUSE	Designed to run to destruction	Idlers can be reused or rebuilt	Idlers and segments can be reused

*Manufacturing requirements include grade of material, heat treatment, form, fit, function and dimensional accuracy.



Cat engineers spent thousands of hours talking to customers, designing and testing undercarriage performance in high abrasion, low-to-medium impact applications. Their mission was to figure out the most effective ways to reduce dry joints and improve sealability to create the lowest cost-per-hour undercarriage. Their efforts paid off.

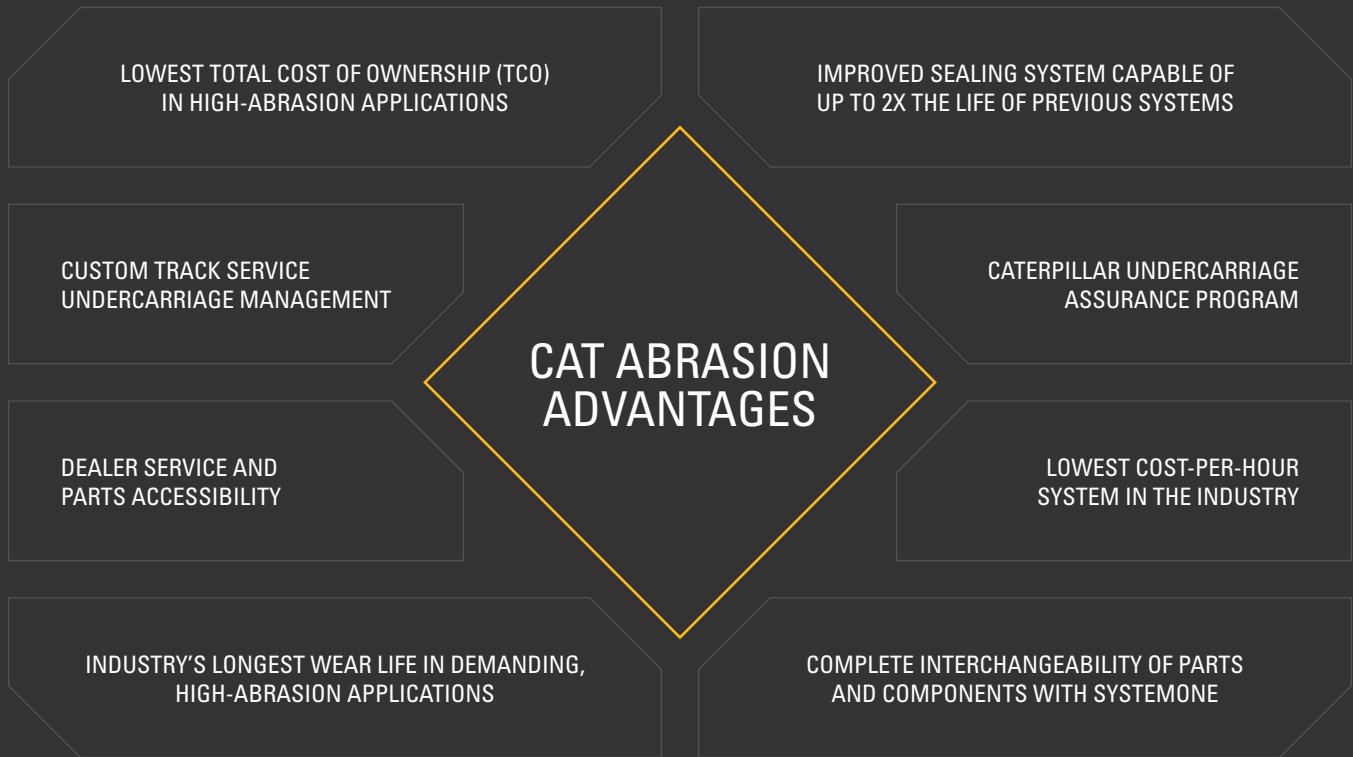

If you work in high-abrasion, low-to-moderate impact applications, take a closer look at Cat Abrasion. The cartridge and seal advancements will deliver undercarriage performance at the industry's lowest cost per hour. Talk to your local Cat dealer or visit [CAT.COM/CATABRASION](https://www.cat.com/catabrasion).



PEDJ0559

© 2020 Caterpillar. All Rights Reserved. CAT, CATERPILLAR, LET'S DO THE WORK, their respective logos, "Caterpillar Corporate Yellow", the "Power Edge" and Cat "Modern Hex" trade dress as well as corporate and product identity used herein, are trademarks of Caterpillar and may not be used without permission.