

Cat® D40 GC

Diesel Generator Sets



Standby : 60 Hz



Image shown might not reflect actual configuration.

Engine Model	Cat® C4.4 In-line 4, 4-cycle diesel
Bore x Stroke	105 mm x 127 mm (4.1 in x 5.0 in)
Displacement	4.4 L (269 in ³)
Compression Ratio	18.2:1
Aspiration	Turbocharged
Fuel Injection System	Common Rail

Model	Standby	Emission Strategy
D40 GC	40 ekW	SCAQMD Complaint (Tier 3 Nonroad Equivalent Emission Standard)

PACKAGE PERFORMANCE

Performance	Standby	
	3-Phase	1-Phase
Frequency	60 Hz	60 Hz
Genset Power Rating	50 kVA	40 kVA
Genset power rating with fan, 3p@ 0.8 & 1p@1.0 power factor	40 ekW	40 ekW
Performance Number	P3454C-00	P3454C-00
Fuel Consumption		
100% load with fan, L/hr (gal/hr)	13.0 (3.4)	13.0 (3.4)
75% load with fan, L/hr (gal/hr)	10.0 (2.6)	10.0 (2.6)
50% load with fan, L/hr (gal/hr)	7.4 (2.0)	7.4 (2.0)
Cooling System¹		
Radiator air flow restriction (system), kPa (in. Water)	0.12 (0.48)	
Engine coolant capacity, L (gal)	7.0 (1.8)	
Radiator coolant capacity, L (gal)	9.5 (2.5)	
Total coolant capacity, L (gal)	16.5 (4.3)	
Inlet Air		
Combustion air inlet flow rate, m ³ /min (cfm)	5.3 (187.2)	5.3 (187.2)
Max. Allowable Combustion Air Inlet Temp, °C (°F)	45 (113)	
Exhaust System		
Exhaust stack gas temperature, °C (°F)	571 (1060)	571 (1060)
Exhaust gas flow rate, m ³ /min (cfm)	13.7 (483.8)	13.7 (484)
Exhaust system backpressure (maximum allowable) kPa (in. water)	15.0 (60.2)	15.0 (60.2)
Heat Rejection		
Heat rejection to exhaust (total) kW (Btu/min)	66.9 (3805)	66.9 (3805)
Heat rejection to atmosphere from engine, kW (Btu/min)	14.9 (847.3)	14.9 (847.3)
Heat Rejection		
NOx + HC, g/kW-hr	4.42	4.42
CO, g/kW-hr	1.02	1.02
PM, g/kW-hr	0.26	0.26

D40 GC Diesel Generator Sets

Electric Power



Alternator ³				
Voltages	480V	208V	600V	240V
Motor starting capability @ 30% Voltage Dip, skVA	72	64	128	85
Current Amps	60	139	48	167
Frame Size	M1736L4	M1754L4	M1736L4	M1754L4
Excitation	SE	SE	AREP	SE
Temperature Rise, °C	130	130	130	130

WEIGHTS & DIMENSIONS

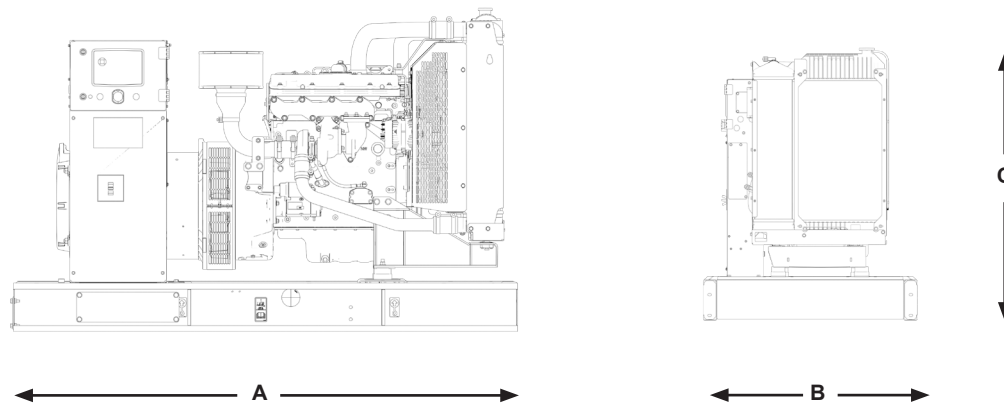

Dim "A" mm (in)	Dim "B" mm (in)	Dim "C" mm (in)	Dry Weight kg (lb)
1962 (77.2)	1100 (43.3)	1220 (48.0)	838 (1847)

Note: General configuration not to be used for installation. See general dimension drawings for detail.

APPLICABLE CODES AND STANDARDS:

AS1359, CSA C22.2 No100-04, UL142, UL489, UL869, UL2200, NFPA37, NFPA70, NFPA99, NFPA110, IBC, IEC60034-1, ISO3046, ISO8528, NEMA MG1-22, NEMA MG1-33, 2006/95/EC, 2006/42/EC, 2004/108/EC.

Note: Codes may not be available in all model configurations. Please consult your local Cat Dealer representative for availability.

STANDBY: Output available with varying load for the duration of the interruption of the normal source power. Average power output is 70% of the standby power rating. Typical operation is 200 hours per year, with maximum expected usage of 500 hours per year.

PRIME: Output available with varying load for an unlimited time. Average power output is 70% of the prime power rating. Typical peak demand is 100% of prime rated kW with 10% overload capability for emergency use for a maximum of 1 hour in 12. Overload operation cannot exceed 25 hours per year.

RATINGS: Ratings are based on SAE J1349 standard conditions. These ratings also apply to ISO3046 standard conditions.

DEFINITIONS AND CONDITIONS

¹ For ambient and altitude capabilities consult your Cat dealer. Air flow restriction (system) is added to existing restriction from factory.

² Emissions data measurement procedures are consistent with those described in EPA CFR 40 Part 89, Subpart D & E and ISO8178-1 for measuring HC, CO, PM, NOx. Data shown is based on steady state operating conditions of 77° F, 28.42 in HG and number 2 diesel fuel with 35° API and LHV of 18,390 BTU/lb. The nominal emissions data shown is subject to instrumentation, measurement, facility and engine to engine variations. Emissions data is based on 100% load and thus cannot be used to compare to EPA regulations which use values based on a weighted cycle.

³ UL 2200 Listed packages may have oversized generators with a different temperature rise and motor starting characteristics. Generator temperature rise is based on a 40° C ambient per NEMA MG1-32.

LET'S DO THE WORK.™

LEHE2670-03 (06/22)

Materials and specifications are subject to change without notice. The International System of Units (SI) is used in this publication.
 © 2022 Caterpillar. All Rights Reserved. CAT, CATERPILLAR, LET'S DO THE WORK, their respective logos, "Caterpillar Corporate Yellow", the "Power Edge" and Cat "Modern Hex" trade dress as well as corporate and product identity used herein, are trademarks of Caterpillar and may not be used without permission.

www.Cat.com/electricpower
 All rights reserved.