



735

Articulated Truck

Technical Specifications

Configurations and features may vary by region. Please consult your Cat® dealer for availability in your area.

Table of Contents

Specifications	2
Engine	2
Weights	2
Air Conditioning System	2
Body Capacities	2
Transmission	2
Sound Levels	2
Operating Weights	3
Body Plate	3
Body Plate Thickness	3
Service Refill Capacities	3
Body Hoist	3
Standards	3
Dimensions	4
Turning Circle	5
Steering	5
Optimal Loader/Truck Pass Matching	5
Gradeability/Speed/Rimpull	6
Retarding Performance	7
Standard and Optional Equipment	8
735 Environmental Declaration	10

735 Articulated Truck Specifications

Engine

Engine Model	Cat® C13	
Gross Power (SAE J1995:2014)	324 kW	434 hp
Net Power (SAE J1349:2011)	316 kW	424 hp
Engine Power (ISO 14396:2002)	320 kW	429 hp
Bore	130 mm	5.1 in
Stroke	157 mm	6.2 in
Displacement	12.5 L	736 in ³

- Advertised power is tested at 1,800 rpm.
- The net power advertised is the power available at the flywheel when the engine is equipped with alternator, air cleaner, muffler, and fan at minimum speed.
- Net power when the fan is at maximum speed is 254 kW (341 hp) per the SAE reference conditions.
- Meets U.S. EPA Tier 4 Final, EU Stage V, Korea Tier 5, and Japan 2014 emission standards.
- Diesel exhaust fluid (DEF) used in Cat SCR systems must meet the requirements outlined in ISO 22241-1. ISO 22241-1 requirements are met by many brands of DEF, including those that carry the AdBlue or API certifications.

No Engine Derating Below	3810 m	12,500 ft
Peak Engine Torque Gross (SAE J1995:2014)	2188 N·m	1,614 lbf·ft
Peak Engine Torque Net (SAE J1349:2011)	2165 N·m	1,597 lbf·ft
Peak Engine Torque Speed	1,200 rpm	

Weights

Rated Payload	32 tonnes	35.3 tons
---------------	-----------	-----------

Air Conditioning System

- The air conditioning system on this machine contains the fluorinated greenhouse gas refrigerant R134a (Global Warming Potential = 1430). The system contains 1.1 kg of refrigerant which has a CO₂ equivalent of 1.716 metric tonnes.

Body Capacities

Heaped SAE 2:1	20.0 m ³	26.2 yd ³
Struck	15.5 m ³	20.3 yd ³
Tailgate Heaped SAE 2:1	21.3 m ³	27.9 yd ³
Tailgate Struck	16.3 m ³	21.3 yd ³

Transmission

Forward 1	8 km/h	5 mph
Forward 2	15 km/h	9 mph
Forward 3	23 km/h	14 mph
Forward 4	35 km/h	22 mph
Forward 5	48 km/h	30 mph
Forward 6	57 km/h	35 mph
Reverse 1	9 km/h	6 mph

Sound Levels

Interior Cab	72 dB(A)
--------------	----------

- The declared dynamic operator sound pressure level is 72 dB(A) when ISO 6396:2008 is used to measure the value for an enclosed cab. The measurement was conducted at 70% of the cooling fan's maximum speed. The sound level may vary at different cooling fan speeds. The measurement was conducted with the cab doors and the cab windows closed. The cab was properly installed and maintained.
- Hearing protection may be needed when operating with an open operator station and cab or when not properly maintained or with doors/windows open for extended periods or in noisy environments.

735 Articulated Truck Specifications

Operating Weights

Front Axle – Empty	15 480 kg	34,128 lb
Center Axle – Empty	4990 kg	11,001 lb
Rear Axle – Empty	4770 kg	10,516 lb
Total – Empty	25 240 kg	55,645 lb
Front Axle – Rated Load	4100 kg	9,039 lb
Center Axle – Rated Load	13 950 kg	30,754 lb
Rear Axle – Rated Load	13 950 kg	30,754 lb
Total – Rated Load	32 000 kg	70,548 lb
Front Axle – Loaded	19 580 kg	43,166 lb
Center Axle – Loaded	18 940 kg	41,756 lb
Rear Axle – Loaded	18 720 kg	41,270 lb
Total – Loaded	57 240 kg	126,192 lb

Body Plate

High strength Brinell HB450 wear resistant steel

Body Plate Thickness

Front Plate	7 mm	0.28 in
Base Plate	13 mm	0.51 in
Side Plates	11 mm	0.43 in

Service Refill Capacities

Fuel Tank	412 L	108.8 gal
DEF Tank	20 L	5.3 gal
Cooling System	83 L	21.9 gal
Hydraulic System	110 L	29.1 gal
Engine Crankcase	38 L	10.0 gal
Transmission	56 L	12.3 gal
Final Drives/Differential	125 L	33.0 gal
Output Transfer Gear Box	25 L	5.5 gal

Body Hoist

Raise Time	12 Seconds
Lower Time	11 Seconds

Standards

Brakes	ISO 3450:2011
Cab/FOPS	ISO 3449:2005 Level II
Cab/ROPS	ISO 3471:2008
Steering	ISO 5010:2019

735 Articulated Truck Specifications

Dimensions

All dimensions are approximate.

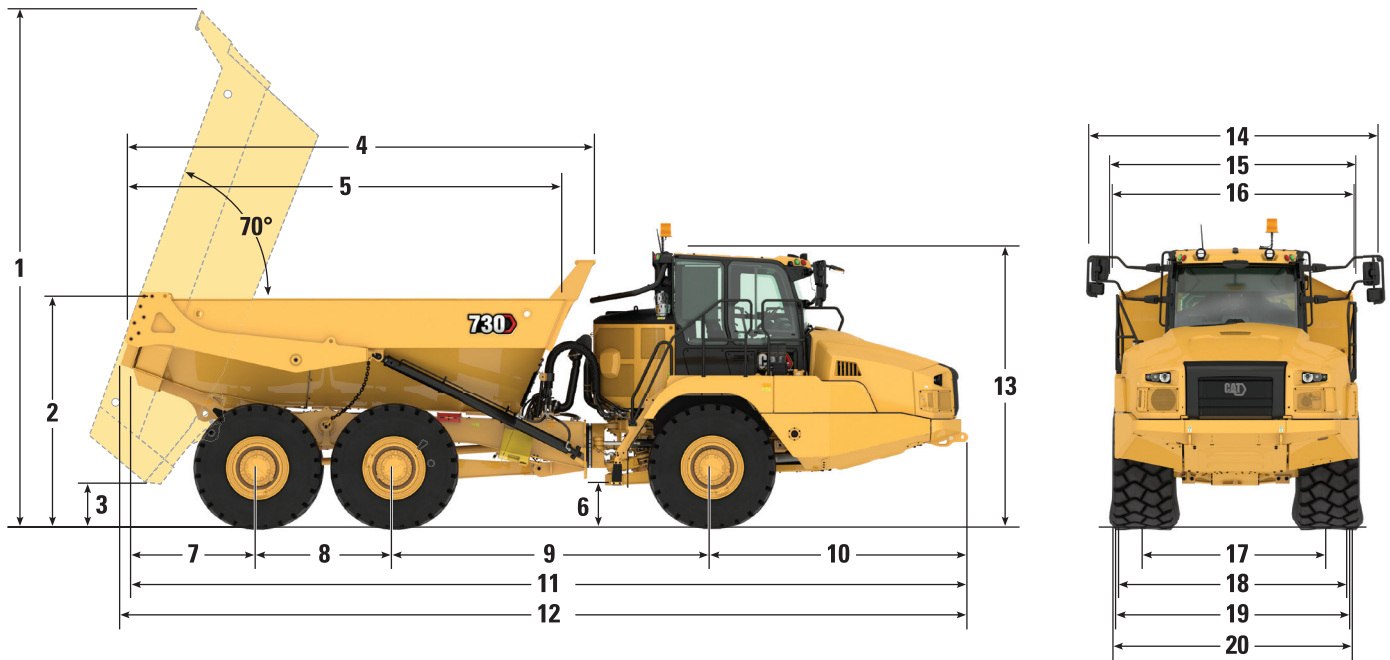

	mm	ft/in
1 Body Height Fully Tipped	6536	21' 5"
2 Load Over Height	3055	10' 1"
3 Ground Clearance – Body Fully Tipped	552	1' 8"
4 Body Length	5823	19' 2"
5 Body Length Inside	5472	18' 0"
6 Ground Clearance	527	1' 8"
7 Rear Axle Center to Body Rear	1556	5' 11"
8 Mid Axle to Rear Axle Center	1700	5' 6"
9 Mid Axle to Front Axle (Centers)	3979	13' 1"
10 Front Axle Center to Machine Front	3210	10' 6"
11 Overall Length	10 445	34' 3"
12 Overall Length with Tailgate	10 573	34' 7"
13 Height Transport Position	3488	11' 5"
14 Overall Width	3676	12' 1"
15 Width Over Tailgate/Width Including Tailgate	3390	11' 2"
16 Body Width	3034	10' 0"
17 Track Width	2275	7' 5"
18 Width Over Tire	2950	9' 7"
19 Width Over Fenders	3013	9' 8"
20 Max Laden Over Tire Bulge	3083	10' 2"

735 Articulated Truck Specifications

Turning Circle

Dimensions are for machines equipped with 750/65 R25 tires.

Turning Dimensions

Steer Angle – From Center Left/Right	45°	
SAE Turning Radius	7470 mm	294 in
Clearance Radius	8075 mm	318 in
Inside Radius	3793 mm	149 in
Aisle Width	5393 mm	212 in

Steering

Lock to Lock 4.75 seconds at 60 rpm

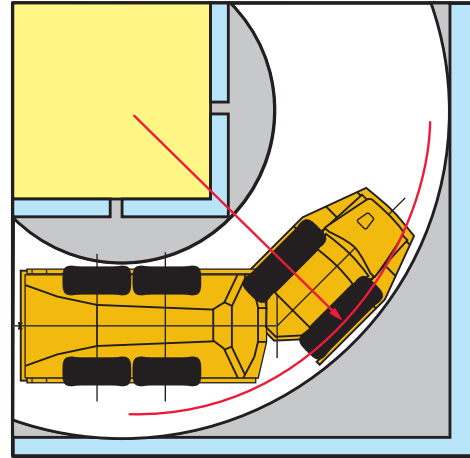

Optimal Loader/Truck Pass Matching

Hydraulic Excavators	349/352			336
Passes	4-5			5-6
Wheel Loaders	972M/972M XE	966M/966M XE	962M	950M
Passes	3-4	4	4-5	5

An optimum system match gives you a major productivity advantage. The 735 is an excellent match for the Cat 349/352 and 336 Hydraulic Excavators and Cat 972M, 966M, 962M, and 950M Wheel Loaders. Having matched loading and hauling tools results in increased production and lower system costs per unit of volume moved.

735 Articulated Truck Specifications

Gradeability/Speed/Rimpull

To determine performance, read from Gross Weight down to % Total Resistance. Total Resistance equals actual % grade plus 1% for each 10 kg/metric ton (20 lb/ton) of Rolling Resistance. From this point, read horizontally to the curve with the highest attainable speed range. Then, go down to Maximum Speed. Usable Rimpull depends on traction available.

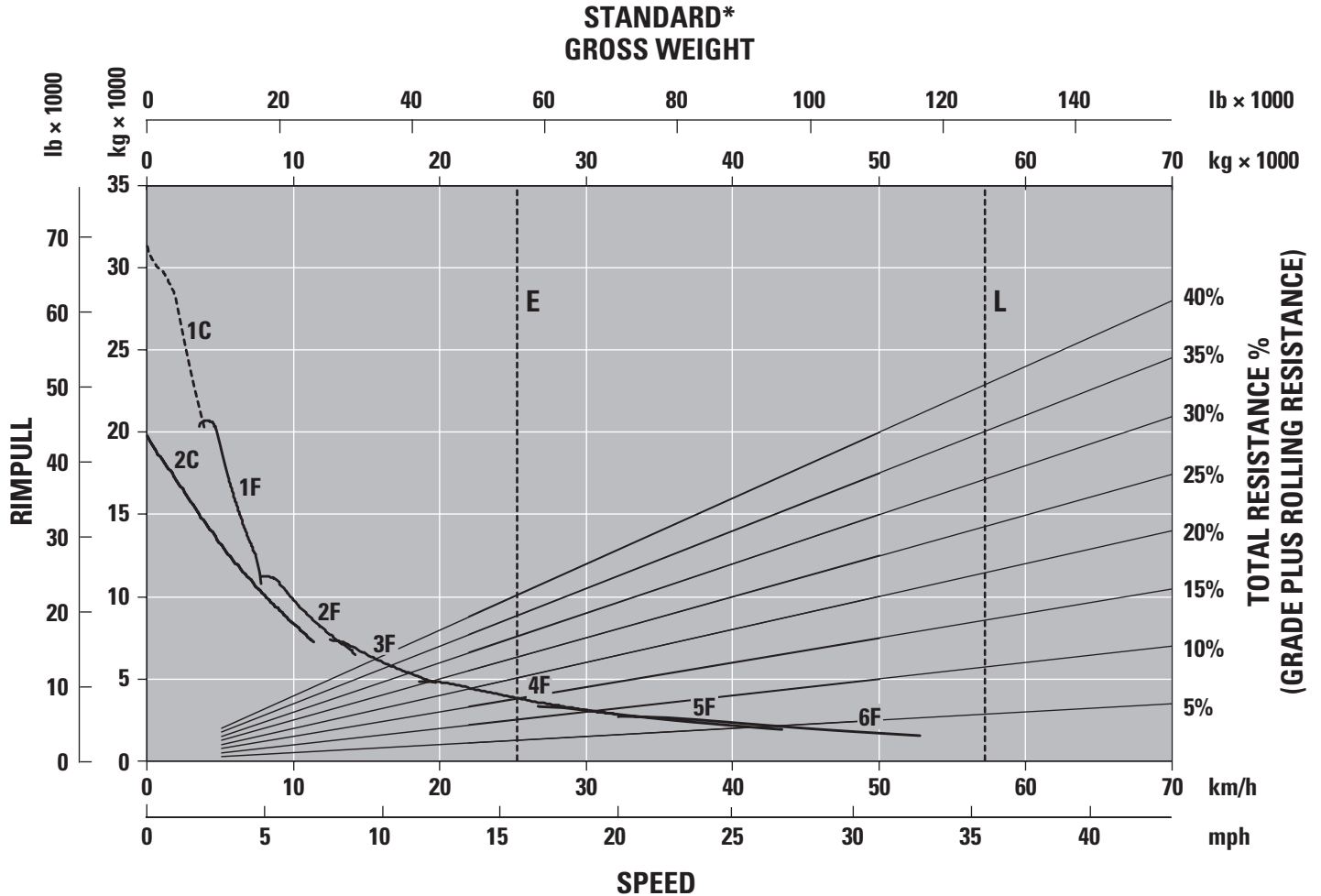

- 1C – 1st Gear (Converter Drive)
- 1F – 1st Gear (Direct Drive)
- 2C – 2nd Gear (Converter Drive)
- 2F – 2nd Gear (Direct Drive)
- 3F – 3rd Gear
- 4F – 4th Gear
- 5F – 5th Gear
- 6F – 6th Gear

- E – Empty 25 240 kg (55,645 lb)
- L – Loaded 57 240 kg (126,192 lb)
- * at sea level

735 Articulated Truck Specifications

Retarding Performance

To determine performance, read from Gross Weight down to % Effective Grade. Effective Grade equals actual % favorable grade plus 1% for each 10 kg/metric ton (20 lb/ton) of Rolling Resistance. From this point, read horizontally to the curve with the highest attainable speed range. Then, go down to Maximum Speed. Retarding effect on these curves represents full application of the retarder.

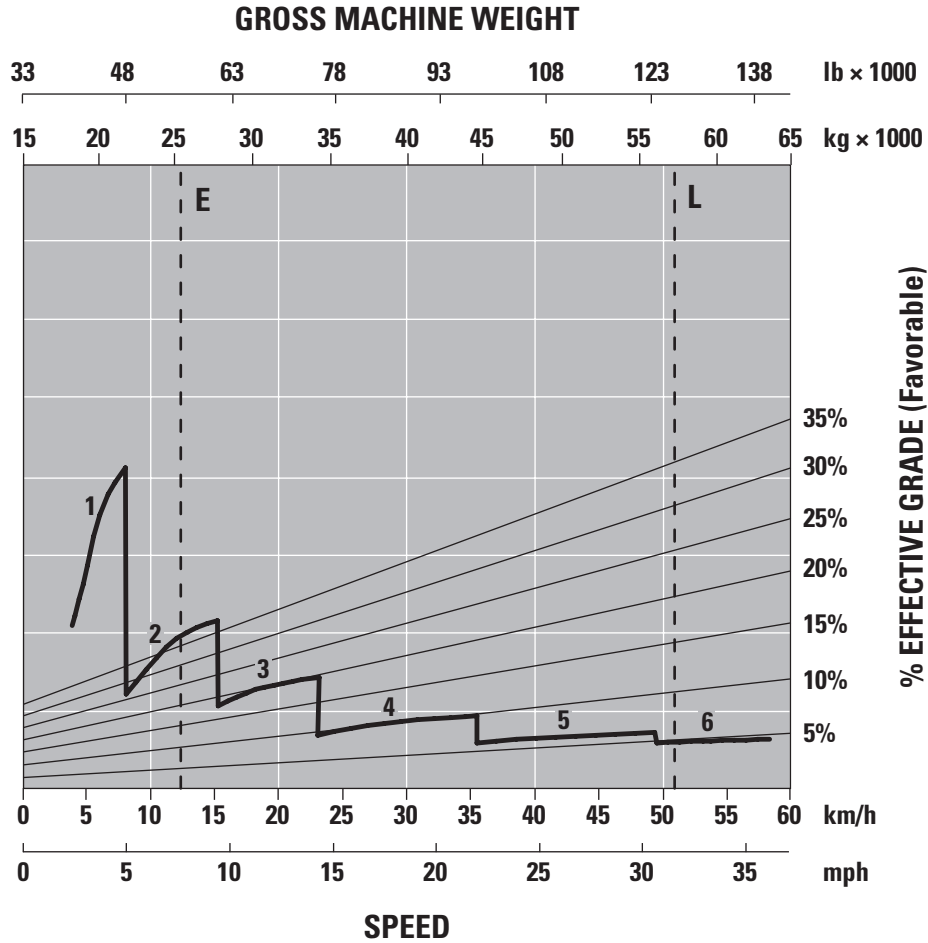

- 1 – 1st Gear
- 2 – 2nd Gear
- 3 – 3rd Gear
- 4 – 4th Gear
- 5 – 5th Gear
- 6 – 6th Gear

- E – Empty 25 240 kg (55,645 lb)
- L – Loaded 57 240 kg (126,192 lb)

735 Articulated Truck Standard & Optional Equipment

Standard and Optional Equipment

Standard and optional equipment may vary. Consult your Cat dealer for details.

	Standard	Optional		Standard	Optional
OPERATOR ENVIRONMENT			TECHNOLOGY		
Air conditioning with R134a refrigerant	✓		Cat Detect with Stability Assist	✓	
Adjustable air vents	✓		Cat Production Measurement payload monitoring system		✓
Combined gear selection and hoist control lever	✓		Machine Security System (MSS)		✓
Glass windows: front, laminated and tinted; sides and rear, toughened and tinted	✓		Product Link™ Elite: PLE641 (cellular)	✓	
Heater and defroster with four-speed fan	✓		Product Link Elite: PLE631 (satellite)		✓
Infrared glass – high ambient cab		✓	ELECTRICAL AND LIGHTING		
Liquid Crystal Display (LCD): alert indicator, selected gear and direction, speed or auto shift, review Operation and Maintenance Manual (OMM), primary steering failure warning, seat belt warning, secondary steering failure warning, Diesel Particulate Filter (DPF) regeneration filter, secondary steering energy source engaged, hour meter, retarder active	✓		Batteries (two) maintenance free	✓	
Mirrors, extensive arrangement for improved visibility	✓		Cold weather start attachment		✓
Mirrors, heated motorized		✓	Engine block heater		✓
Machine operation monitoring system: action lamp, engine oil pressure, primary steering system, left and right turn signal, high beam, coolant temperature, tachometer, parking brake, fuel level, transmission oil temperature, brake system, transmission hold, hoist control, hydraulic system, charging system, retarder, transmission fault, traction control system, check engine lamp	✓		Ether start		✓
Radio, Bluetooth® stereo system		✓	Electrical system: 24-volt, 5A 24- to 12-volt converter	✓	
Seats: operator – fully adjustable, air suspension, retractable lap belt; trainer – padded with retractable lap belt	✓		Flashing LED beacon		✓
Seat, heated/cooled		✓	Horn	✓	
Operator seat belt, four-point		✓	Lighting systems: cab interior, two head lamps, two width marker, two reversing, work light/cab access light, two stop/tail lights, front and rear direction indicators	✓	
Secondary steering, electro hydraulic	✓		Main disconnect switch		✓
Storage: cup holder, flask receptacle, under seat storage, door pocket, behind operator seat storage, coat hook	✓		Remote starting receptacle (cables not included)	✓	
Sun visor	✓		Roof-mounted High Intensity Discharge (HID) work lights		✓
Tilt and telescopic steering wheel	✓		POWER TRAIN		
Touchscreen display incorporating the rearview camera video feed	✓		Auto shift six-speed forward and single-speed reverse transmission	✓	
Window blinds		✓	Cat C13 engine		✓
Windows (tinted) opening side	✓		CX31 transmission		✓
Windshield wiper and washer, two speed, intermittent (front)	✓		Cat Clean Emission Module (CEM) and exhaust aftertreatment package	✓	
Window wiper and washer, two speed (rear)	✓		Differentials: standard with automatic clutched inter- and cross-axle differential locks	✓	
			Dual circuit oil immersed, enclosed brakes – all wheels	✓	
			Retarder: engine compression brake and hydraulic	✓	
			Three axle, six-wheel drive	✓	
			SAFETY		
			Reverse alarm	✓	
			Rearview camera	✓	
			ROPS/FOPS cab	✓	
			GUARDS		
			Axle	✓	
			Crankcase	✓	
			Front dump body spill guard, integral part of fabricated body	✓	
			Radiator	✓	
			Rear window	✓	

735 Articulated Truck Standard & Optional Equipment

Standard and Optional Equipment

Standard and optional equipment may vary. Consult your Cat dealer for details.

	Standard	Optional
OTHER STANDARD AND OPTIONAL EQUIPMENT		
Auto lube installation for automatic greasing of bearings		✓
Bare chassis (no body) standard wheel base		✓
Bare chassis (no body) long wheel base		✓
Body liners		✓
Cold weather coolant -51°C (-60°F)		✓
Exhaust heated body		✓
Fast fuel fill		✓
Fuel additive, anti-waxing		✓

	Standard	Optional
OTHER STANDARD AND OPTIONAL EQUIPMENT (CONTINUED)		
Mud flaps: wheel arch and body mounted with transportation tiebacks		✓
Scissor tailgate		✓
S·O·S SM sampling valves		✓
Sound suppression (standard in EFTA*)		✓
Sound suppression (optional outside EFTA*)		✓
Tires, six 750/65 R25		✓
Vandalism protection: lockable caps		✓
Wheel chocks		✓

* EFTA countries are EU countries plus Iceland, Norway, Lichtenstein, and Switzerland.

735 Environmental Declaration

The following information applies to the machine at the time of final manufacture as configured for sale in the regions covered in this document. The content of this declaration is valid as of the date issued; however, content related to machine features and specifications are subject to change without notice. For additional information, please see the machine's Operation and Maintenance Manual.

For more information on sustainability in action and our progress, please visit <https://www.caterpillar.com/en/company/sustainability>.

Engine

- The Cat® C13 engine meets U.S. EPA Tier 4 Final, EU Stage V, Korea Tier 5, and Japan 2014 emission standards.
- Cat diesel engines are required to use ULSD (ultra-low sulfur diesel fuel with 15 ppm of sulfur or less) or ULSD blended with the following lower-carbon intensity fuels up to:
 - ✓ 20% biodiesel FAME (fatty acid methyl ester)*
 - ✓ 100% renewable diesel, HVO (hydrotreated vegetable oil) and GTL (gas-to-liquid) fuels

Refer to guidelines for successful application. Please consult your Cat dealer or “Caterpillar Machine Fluids Recommendations” (SEBU6250) for details.

**Engines with no aftertreatment devices can use higher blends, up to 100% biodiesel.*

Air Conditioning System

- The air conditioning system on this machine contains the fluorinated greenhouse gas refrigerant R134a (Global Warming Potential = 1430). The system contains 1.1 kg (2.4 lb) of refrigerant which has a CO2 equivalent of 1.716 metric tonnes (1.891 tons).

Paint

- Based on best available knowledge, the maximum allowable concentration, measured in parts per million (PPM), of the following heavy metals in paint are:
 - Barium < 0.01%
 - Cadmium < 0.01%
 - Chromium < 0.01%
 - Lead < 0.01%

Sound Performance

Interior Cab	72 dB(A)
--------------	----------

- The declared dynamic operator sound pressure level is 72 dB(A) when ISO 6396:2008 is used to measure the value for an enclosed cab. The measurement was conducted at 70% of the maximum cooling fan's speed. The sound level may vary at different cooling fan speeds. The measurement was conducted with the cab doors and the cab windows closed. The cab was properly installed and maintained.
- Hearing protection may be needed when operating with an open operator station and cab or when not properly maintained or doors/windows open for extended periods or in noisy environments.

Oils and Fluids

- Caterpillar factory fills with ethylene glycol coolants. Cat Diesel Engine Antifreeze/Coolant (DEAC) and Cat Extended Life Coolant (ELC) can be recycled. Consult your Cat dealer for more information.
- Cat Bio HYDO™ Advanced is an EU Ecolabel approved biodegradable hydraulic oil.
- Additional fluids are likely to be present, please consult the Operations and Maintenance Manual or the Application and Installation guide for complete fluid recommendations and maintenance intervals.

Features and Technology

- The following features and technology may contribute to fuel savings and/or carbon reduction. Features may vary. Consult your Cat dealer for details.
 - Economy mode minimizes fuel consumption without impacting productivity
 - Optimize airflow and enhance power and fuel efficiency with innovative air-management systems
 - Maximize uptime and reduce cost with world-class support from the Cat dealer network
 - Uniquely combined hoist and transmission level allows for easy, intuitive control and cuts operator interaction by as much as 50%

For more complete information on Cat products, dealer services, and industry solutions, visit us on the web at www.cat.com.

Materials and specifications are subject to change without notice. Featured machines in photos may include additional equipment. See your Cat dealer for available options.

© 2022 Caterpillar. All Rights Reserved. CAT, CATERPILLAR, LET'S DO THE WORK, their respective logos, Product Link, S•O•S, "Caterpillar Corporate Yellow", the "Power Edge" and Cat "Modern Hex" trade dress as well as corporate and product identity used herein, are trademarks of Caterpillar and may not be used without permission.

AEXQ2712-02 (8-2022)
Build Number: 04A
(Aus-NZ, Europe,
Japan, N Am)

