



315 GC

Hydraulic Excavator

Technical Specifications

Configurations and features may vary by region. Please consult your Cat® dealer for availability in your area.

Table of Contents

Specifications	2
Engine	2
Swing Mechanism	2
Weights	2
Track	2
Drive	2
Hydraulic System	2
Service Refill Capacities	2
Standards	2
Sound Performance	2
Operating Weights and Ground Pressures	3
Major Component Weights	4
Dimensions	5
Working Ranges and Forces	7
Blade Working Ranges	8
Reach Boom Lift Capacities	9
Reach Boom Lift Capacities – Blade Up	15
Bucket Specifications and Compatibility	21
Attachments Offering Guide	22
Thumb Specifications	23
Standard and Optional Equipment	24
Dealer Installed Kits and Attachments	26
315 GC Environmental Declaration	27

315 GC Hydraulic Excavator Specifications

Engine

Engine Model	Cat® C3.6	
Net Power		
ISO 9249	73.3 kW	98 hp
ISO 9249 (DIN)	100 hp (metric)	
Engine Power		
ISO 14396	74.4 kW	100 hp
ISO 14396 (DIN)	101 hp (metric)	
Bore	98 mm	4 in
Stroke	120 mm	5 in
Displacement	3.6 L	220 in ³
Biodiesel capability	Up to B20 ⁽¹⁾	

- Meets U.S. EPA Tier 4 Final, EU Stage V, and Japan 2014 emission standards.
- No engine power derating required below 3000 m (9,840 ft) altitude.
- Advertised power is tested per the specified standard in effect at the time of manufacture.
- Net power advertised is the power available at the flywheel when the engine is equipped with fan, air intake system, exhaust system and alternator.
- Engine speed at 2,400 rpm.

⁽¹⁾Cat diesel engines are required to use ULSD (ultra-low sulfur diesel fuel with 15 ppm of sulfur or less) or ULSD blended with the following lower-carbon intensity fuels** up to:

- ✓ 20% biodiesel FAME (fatty acid methyl ester)*
- ✓ 100% renewable diesel, HVO (hydrotreated vegetable oil) and GTL (gas-to-liquid) fuels

Refer to guidelines for successful application. Please consult your Cat dealer or “Caterpillar Machine Fluids Recommendations” (SEBU6250) for details.

*Engines with no aftertreatment devices can use higher blends, up to 100% biodiesel (for use of blends higher than 20% biodiesel, consult your Cat dealer).

**Tailpipe greenhouse gas emissions from lower-carbon intensity fuels are essentially the same as traditional fuels.

Swing Mechanism

Swing Speed	11.5 rpm	
Maximum Swing Torque	35 kN·m	25,815 lbf·ft

Weights

Operating Weight	15 400 kg	33,900 lb
------------------	-----------	-----------

- Long undercarriage, Reach boom, R3.0 (9'10") stick, GD 0.53 m³ (0.69 yd³) bucket, 700 mm (28") triple grouser shoes and 3.83 mt (8,440 lb) counterweight.

Track

Standard Track Shoes Width	700 mm	28 in
Optional Track Shoes Width	600 mm	24 in
Optional Track Shoes Width	500 mm	20 in
Number of Shoes (each side)	46	
Number of Track Rollers (each side)	7	
Number of Carrier Rollers (each side)	1	

Drive

Gradeability	35°/70%	
Maximum Travel Speed	5.4 km/h	3.4 mph
Maximum Drawbar Pull	117 kN	26,303 lbf

Hydraulic System

Main System – Maximum Flow – Implement	247 L/min	65 gal/min
Maximum Pressure – Equipment – Normal	35 000 kPa	5,075 psi
Maximum Pressure – Travel	35 000 kPa	5,075 psi
Maximum Pressure – Swing	26 000 kPa	3,770 psi
Boom Cylinder – Bore	105 mm	4 in
Boom Cylinder – Stroke	1023 mm	40 in
Stick Cylinder – Bore	115 mm	5 in
Stick Cylinder – Stroke	1147 mm	45 in
Bucket Cylinder – Bore	95 mm	4 in
Bucket Cylinder – Stroke	939 mm	37 in

Service Refill Capacities

Fuel Tank Capacity	187 L	49.4 gal
Cooling System	15 L	4.0 gal
Engine Oil	8 L	2.1 gal
Final Drive (each)	3 L	0.8 gal
Hydraulic System (including tank)	85 L	22.5 gal
Hydraulic Tank	72 L	19.0 gal
Diesel Exhaust Fluid (DEF) Tank	21 L	5.5 gal

Standards

Brakes	ISO 10265:2008
Cab/Rollover Protective Structure (ROPS)	ISO 12117-2:2008
Cab/Operator Protective Guards (OPG) (optional)	ISO 10262:1998 (Level II)

Sound Performance

ISO 6395:2008 (external)	101 dB(A)
ISO 6396:2008 (inside cab)	71 dB(A)

- Hearing protection may be needed when operating with an open operator station and cab (when not properly maintained or doors/windows open) for extended periods or in a noisy environment.

315 GC Hydraulic Excavator Specifications

Operating Weights and Ground Pressures

Base Machine Configurations	500 mm (20") Triple Grouser Shoes		500 mm (20") Triple Grouser Shoes with Rubber Pad		500 mm (20") Rubber Shoes	
	Weight	Ground Pressure	Weight	Ground Pressure	Weight	Ground Pressure
	kg (lb)	kPa (psi)	kg (lb)	kPa (psi)	kg (lb)	kPa (psi)
Base Frame with Track Rollers and Carrier Rollers						
Base machine with 3.83 mt (8,440 lb) counterweight and long undercarriage						
Reach Boom + R2.8 (9'2") Stick + 0.53 m ³ (0.69 yd ³) GD Bucket	14 900 (32,800)	44.4 (6.4)	15 300 (33,700)	45.6 (6.6)	14 900 (33,100)	44.8 (6.5)
Reach Boom + R2.8 (9'2") Thumb Ready Stick + 0.53 m ³ (0.69 yd ³) GD Bucket	14 900 (33,000)	44.4 (6.4)	15 400 (33,900)	45.8 (6.6)	15 100 (33,200)	45.0 (6.5)
Reach Boom + R3.0 (9'10") Stick + 0.53 m ³ (0.69 yd ³) GD Bucket	14 900 (32,800)	44.4 (6.4)	15 300 (33,700)	45.6 (6.6)	14 900 (33,100)	44.8 (6.5)
Reach Boom + R2.8 (9'2") Stick + 0.53 m ³ (0.69 yd ³) GD Bucket + Blade	15 600 (34,400)	46.5 (6.7)	16 000 (35,300)	47.8 (6.9)	15 600 (34,800)	47.1 (6.8)
Reach Boom + R2.8 (9'2") Thumb Ready Stick + 0.53 m ³ (0.69 yd ³) GD Bucket + Blade	15 700 (34,500)	46.7 (6.8)	16 100 (35,500)	48.0 (7.0)	15 800 (34,800)	47.1 (6.8)
Reach Boom + R3.0 (9'10") Stick + 0.53 m ³ (0.69 yd ³) GD Bucket + Blade	15 600 (34,400)	46.5 (6.7)	16 000 (35,300)	47.8 (6.9)	15 600 (34,700)	46.9 (6.8)

All operating weights include a 90% fuel tank with 75 kg (165 lb) operator.

Base Machine Configurations	600 mm (24") Triple Grouser Shoes		600 mm (24") Rubber Shoes		700 mm (28") Triple Grouser Shoes	
	Weight	Ground Pressure	Weight	Ground Pressure	Weight	Ground Pressure
	kg (lb)	kPa (psi)	kg (lb)	kPa (psi)	kg (lb)	kPa (psi)
Base Frame with Track Rollers and Carrier Rollers						
Base machine with 3.83 mt (8,440 lb) counterweight and long undercarriage						
Reach Boom + R2.8 (9'2") Stick + 0.53 m ³ (0.69 yd ³) GD Bucket	15 200 (33,400)	37.7 (5.5)	15 300 (33,700)	38.0 (5.5)	15 400 (33,900)	35.5 (5.1)
Reach Boom + R2.8 (9'2") Thumb Ready Stick + 0.53 m ³ (0.69 yd ³) GD Bucket	15 200 (33,600)	37.8 (5.5)	15 400 (33,900)	38.2 (5.5)	15 400 (34,000)	35.7 (5.2)
Reach Boom + R3.0 (9'10") Stick + 0.53 m ³ (0.69 yd ³) GD Bucket	15 200 (33,400)	37.7 (5.5)	15 300 (33,800)	38.1 (5.5)	15 400 (33,900)	35.5 (5.1)
Reach Boom + R2.8 (9'2") Stick + 0.53 m ³ (0.69 yd ³) GD Bucket + Blade	16 000 (35,100)	39.6 (5.7)	16 100 (35,500)	40.0 (5.8)	16 200 (35,600)	37.3 (5.4)
Reach Boom + R2.8 (9'2") Thumb Ready Stick + 0.53 m ³ (0.69 yd ³) GD Bucket + Blade	16 000 (35,300)	39.8 (5.8)	16 200 (35,600)	40.1 (5.8)	16 200 (35,700)	37.4 (5.4)
Reach Boom + R3.0 (9'10") Stick + 0.53 m ³ (0.69 yd ³) GD Bucket + Blade	16 000 (35,100)	39.6 (5.7)	16 100 (35,500)	40.0 (5.8)	16 200 (35,600)	37.3 (5.4)

All operating weights include a 90% fuel tank with 75 kg (165 lb) operator.

315 GC Hydraulic Excavator Specifications

Major Component Weights

	kg	lb
Base Machine Weight: Base machine (with 3.83 mt [8,440 lb] counterweight, upper frame, long undercarriage – does not include boom, stick, bucket, boom cylinders, stick cylinders, bucket cylinders, tracks, blade, fuel tank, operator).		
With Long Undercarriage	10 770	23,730
With Long Undercarriage (blade compatible)	11 050	24,360
Track Shoes:		
500 mm (20") Triple Grouser Track Shoes	1540	3,390
500 mm (20") Triple Grouser Track Shoes with Rubber Pad	1950	4,310
500 mm (20") Rubber Shoes	1670	3,680
600 mm (24") Triple Grouser Track Shoes	1810	4,000
600 mm (24") Rubber Shoes	1970	4340
700 mm (28") Triple Grouser Track Shoes with Additional Steps	2020	4,440
Two Boom Cylinders	250	550
Weight of 90% Fuel Tank and 75 kg (165 lb) Operator	210	460
Blades (without lines, cylinders, frame modifications):		
2500 mm (8'2") Blade for use with 500 mm (20") Track Shoes	440	960
2600 mm (8'6") Blade for use with 600 mm (24") Track Shoes	490	1,080
2700 mm (8'10") Blade for use with 700 mm (28") Track Shoes	500	1,110
Counterweight:		
3.83 mt (8,440 lb) Counterweight	3830	8,440
Swing Frame	1420	3,140
Undercarriages:		
Base Frame with GD Track Rollers and One Carrier Roller	2620	5,770
Base Frame with GD Track Rollers and One Carrier Roller (blade compatible)	2900	6,390
Boom (including lines, pins, stick cylinder):		
Reach Boom 4.65 m (15'3")	1030	2,270
Sticks (including lines, pins, bucket cylinder, bucket linkage):		
Reach Stick 2.8 m (9'2")	640	1,400
Thumb Ready Stick R2.8 (9'2")	720	1,600
Reach Stick R3.0 m (9'10")	650	1,440
Buckets (without linkage, with tips and side cutters):		
0.53 m ³ (0.69 yd ³) GD Bucket	440	970
0.53 m ³ (0.69 yd ³) SD Bucket	500	1100
0.65 m ³ (0.85 yd ³) GD Bucket	470	1030
0.65 m ³ (0.85 yd ³) SD Bucket	540	1200
0.76 m ³ (0.99 yd ³) GD Bucket	510	1120
Quick Coupler:		
Pin Grabber Quick Coupler	210	470

315 GC Hydraulic Excavator Specifications

Dimensions

All dimensions are approximate and may vary depending on bucket selection.

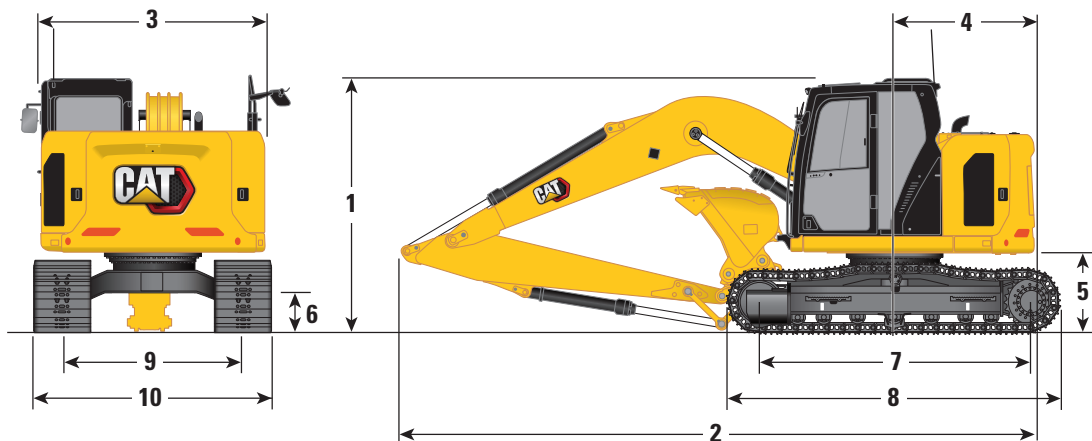

Boom Option	Reach Boom 4.65 m (15'3")					
Stick Options	Reach Stick R2.8 (9'2")		Thumb Ready Stick R2.8 (9'2")		Reach Stick R3.0 (9'10")	
1 Machine Height:						
Top of Cab Height	2810 mm	9'3"	2810 mm	9'3"	2810 mm	9'3"
Top of OPG Height	2960 mm	9'9"	2960 mm	9'9"	2960 mm	9'9"
Handrail Height	2860 mm	9'5"	2860 mm	9'5"	2860 mm	9'5"
With Boom/Stick/Bucket Installed (with stick cylinder lines)	3070 mm	10'1"	3070 mm	10'1"	3180 mm	10'5"
With Boom/Stick Installed (with stick cylinder lines)	3070 mm	10'1"	3070 mm	10'1"	3180 mm	10'5"
With Boom Installed (with stick cylinder lines)	2410 mm	7'11"	2410 mm	7'11"	2410 mm	7'11"
Machine Height (with 500 mm [20"] rubber shoes):						
Top of Cab Height	2860 mm	9'5"	2860 mm	9'5"	2860 mm	9'5"
Top of OPG Height	3010 mm	9'11"	3010 mm	9'11"	3010 mm	9'11"
Handrails Height	2910 mm	9'7"	2910 mm	9'7"	2910 mm	9'7"
With Boom/Stick/Bucket Installed (with stick cylinder lines)	3120 mm	10'3"	3120 mm	10'3"	3230 mm	10'7"
With Boom/Stick Installed (with stick cylinder lines)	3120 mm	10'3"	3120 mm	10'3"	3230 mm	10'7"
With Boom Installed (with stick cylinder lines)	2460 mm	8'1"	2460 mm	8'1"	2460 mm	8'1"
2 Machine Length (without blade):						
With Boom/Stick/Bucket Installed (with stick cylinder lines)	7570 mm	24'10"	7570 mm	24'10"	7530 mm	24'8"
With Boom/Stick Installed (with stick cylinder lines)	7570 mm	24'10"	7570 mm	24'10"	7530 mm	24'8"
With Boom Installed (with stick cylinder lines)	6640 mm	21'9"	6640 mm	21'9"	6640 mm	21'9"
Machine Length (with blade, blade rear):						
With Boom/Stick/Bucket Installed (with stick cylinder lines)	8130 mm	26'8"	8130 mm	26'8"	8090 mm	26'7"
With Boom/Stick Installed (with stick cylinder lines)	8130 mm	26'8"	8130 mm	26'8"	8090 mm	26'7"
With Boom Installed (with stick cylinder lines)	7200 mm	23'7"	7200 mm	23'7"	7200 mm	23'7"
Bucket Type	GD		GD		GD	
Bucket Capacity	0.65 m ³	0.85 yd ³	0.65 m ³	0.85 yd ³	0.53 m ³	0.69 yd ³
Bucket Tip Radius	1240 mm	4'1"	1240 mm	4'1"	1240 mm	4'1"

315 GC Hydraulic Excavator Specifications

Dimensions

All dimensions are approximate and may vary depending on bucket selection.

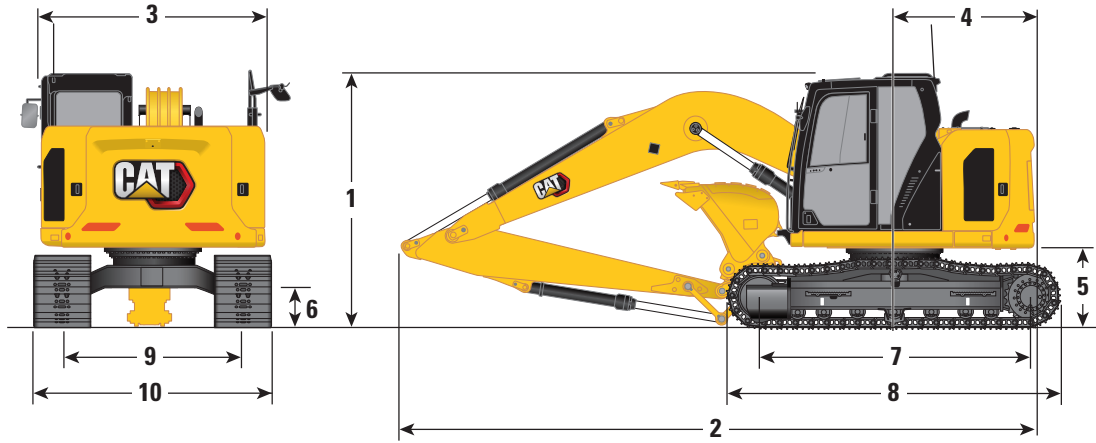

Boom Option

Reach Boom 4.65 m (15'3")

Stick Options

Reach Stick R2.8 (9'2")

Thumb Ready Stick R2.8 (9'2")

Reach Stick R3.0 (9'10")

Stick Options	Reach Stick R2.8 (9'2")		Thumb Ready Stick R2.8 (9'2")		Reach Stick R3.0 (9'10")	
3 Upperframe Width	2480 mm	8'2"	2480 mm	8'2"	2480 mm	8'2"
4 Tail Swing Radius –3.83 mt (8,440 lb) Counterweight	1570 mm	5'2"	1570 mm	5'2"	1570 mm	5'2"
5 Counterweight Clearance	880 mm	2'11"	880 mm	2'11"	880 mm	2'11"
6 Ground Clearance	440 mm	1'5"	440 mm	1'5"	440 mm	1'5"
7 Length to Center of Rollers	3040 mm	10'0"	3040 mm	10'0"	3040 mm	10'0"
8 Overall Track Length	3750 mm	12'4"	3750 mm	12'4"	3750 mm	12'4"
9 Track Gauge	1990 mm	6'6"	1990 mm	6'6"	1990 mm	6'6"
10 Track Width/Undercarriage Width:						
500 mm (20") Shoes	2490 mm	8'2"	2490 mm	8'2"	2490 mm	8'2"
600 mm (24") Shoes	2590 mm	8'6"	2590 mm	8'6"	2590 mm	8'6"
700 mm (28") Shoes (with steps)	2690 mm	8'10"	2690 mm	8'10"	2690 mm	8'10"
Bucket Type	GD		GD		GD	
Bucket Capacity	0.65 m ³	0.85 yd ³	0.65 m ³	0.85 yd ³	0.53 m ³	0.69 yd ³
Bucket Tip Radius	1240 mm	4'1"	1240 mm	4'1"	1240 mm	4'1"

315 GC Hydraulic Excavator Specifications

Working Ranges and Forces

All dimensions are approximate and may vary depending on bucket selection.

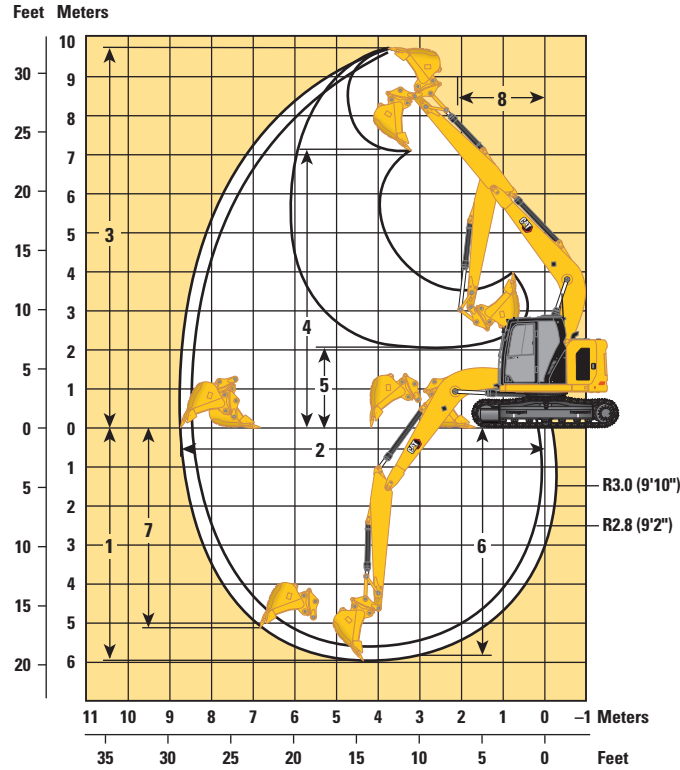

Boom Options

Reach Boom
4.65 m (15'3")

Stick Options

Reach Stick
R2.8 (9'2")

Thumb Ready Stick
R2.8 (9'2")

Reach Stick
R3.0 (9'10")

	Reach Stick R2.8 (9'2")		Thumb Ready Stick R2.8 (9'2")		Reach Stick R3.0 (9'10")	
1 Maximum Digging Depth	5790 mm	19'0"	5790 mm	19'0"	5990 mm	19'8"
2 Maximum Reach at Ground Line	8500 mm	27'11"	8500 mm	27'11"	8690 mm	28'6"
3 Maximum Cutting Height	9540 mm	31'4"	9540 mm	31'4"	9690 mm	31'9"
4 Maximum Loading Height	7060 mm	23'2"	7060 mm	23'2"	7220 mm	23'8"
5 Minimum Loading Height	2260 mm	7'5"	2260 mm	7'5"	2080 mm	6'10"
6 Maximum Depth Cut for 2440 mm (8'0") Level Bottom	5600 mm	18'4"	5600 mm	18'4"	5810 mm	19'1"
7 Maximum Vertical Wall Digging Depth	4990 mm	16'4"	4990 mm	16'4"	5180 mm	17'0"
8 Minimum Working Equipment Radius	2170 mm	7'1"	2170 mm	7'1"	2240 mm	7'4"
Bucket Digging Force (ISO)	98.67 kN	22,180 lbf	98.67 kN	22,180 lbf	98.67 kN	22,180 lbf
Stick Digging Force (ISO)	62.34 kN	14,010 lbf	62.34 kN	14,010 lbf	59.29 kN	13,330 lbf
Bucket Type	GD		GD		GD	
Bucket Capacity	0.65 m ³	0.85 yd ³	0.65 m ³	0.85 yd ³	0.53 m ³	0.69 yd ³
Bucket Tip Radius	1240 mm	4'1"	1240 mm	4'1"	1240 mm	4'1"

315 GC Hydraulic Excavator Specifications

Blade Working Ranges

All dimensions are approximate and may vary depending on bucket selection.

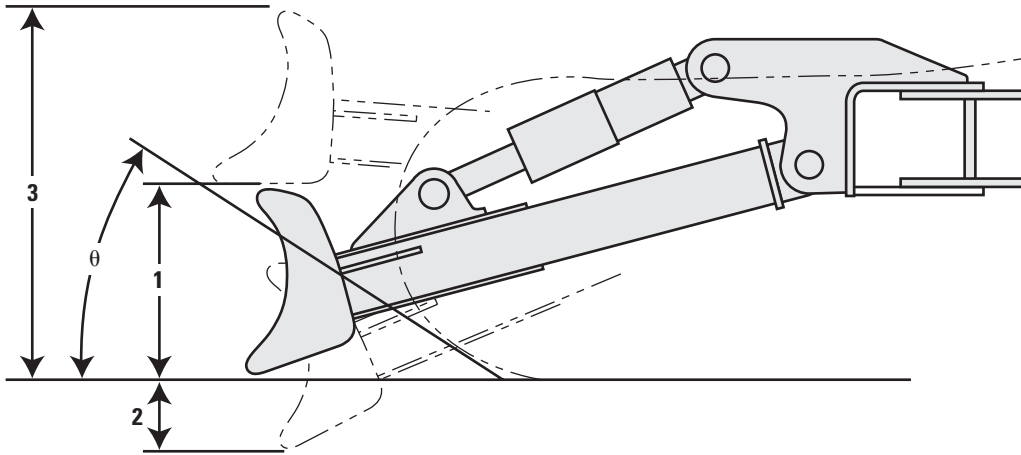







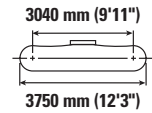
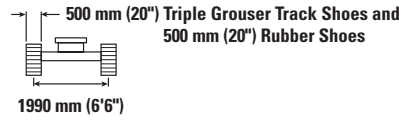
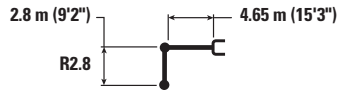



Blade Options	2500 mm (8'2")		2600 mm (8'6")		2700 mm (8'10")	
	1 Blade Height	616 mm	2'0"	616 mm	2'0"	616 mm
2 Maximum Lowering Depth from Ground	550 mm	1'10"	550 mm	1'10"	550 mm	1'10"
3 Maximum Raising Height above Ground	1018 mm	3'4"	1018 mm	3'4"	1018 mm	3'4"
θ Approach Angle	26°		26°		26°	

315 GC Hydraulic Excavator Specifications









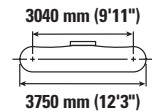
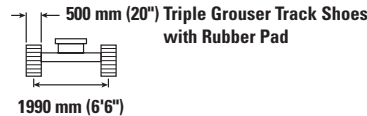
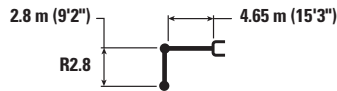

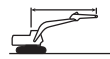
Reach Boom Lift Capacities – Counterweight: 3.83 mt (8,440 lb) – without Bucket



		1500 mm (5'0")		3000 mm (10'0")		4500 mm (15'0")		6000 mm (20'0")				mm ft/in
												
7500 mm 25'0"	kg lb									*2850 *6,500	*2850 *6,500	4210 13'2"
6000 mm 20'0"	kg lb					*3700 *8,100	*3700 *8,100			*2400 *5,250	*2400 *5,250	5830 18'10"
4500 mm 15'0"	kg lb					*4000 *8,700	*4000 *8,700	*3600 *7,650	2600 5,550	*2250 *4,900	2100 4,650	6750 22'0"
3000 mm 10'0"	kg lb			*6850 *14,750	*6850 *14,750	*4900 *10,650	3900 8,350	3900 8,400	2500 5,350	*2250 *4,900	1850 4,050	7240 23'8"
1500 mm 5'0"	kg lb			*8950 *19,250	6500 14,000	*5700 *12,250	3600 7,750	3800 8,100	2400 5,100	*2350 *5,150	1750 3,800	7400 24'3"
0 mm 0'0"	kg lb			*6700 *15,500	6100 13,100	5650 12,100	3400 7,300	3650 7,850	2300 4,900	*2600 *5,750	1750 3,850	7240 23'8"
-1500 mm -5'0"	kg lb	*4500 *10,050	*4500 *10,050	*8250 *17,900	6000 12,900	5550 11,900	3300 7,100	3600 7,750	2250 4,800	3100 6,800	1950 4,250	6740 22'0"
-3000 mm -10'0"	kg lb	*7950 *17,900	*7950 *17,900	*6300 *13,550	6100 13,100	*4450 *9,550	3300 7,150			*2950 *6,450	2400 5,250	5810 18'10"
-4500 mm -15'0"	kg lb									*2100	*2100	3930

Reach Boom Lift Capacities – Counterweight: 3.83 mt (8,440 lb) – without Bucket



		1500 mm (5'0")		3000 mm (10'0")		4500 mm (15'0")		6000 mm (20'0")				mm ft/in
												
7500 mm 25'0"	kg lb									*2850 *6,500	*2850 *6,500	4210 13'2"
6000 mm 20'0"	kg lb					*3700 *8,100	*3700 *8,100			*2400 *5,250	*2400 *5,250	5830 18'10"
4500 mm 15'0"	kg lb					*4000 *8,700	*4000 *8,700	*3600 *7,650	2650 5,700	*2250 *4,900	2150 4,800	6750 22'0"
3000 mm 10'0"	kg lb			*6850 *14,750	*6850 *14,750	*4900 *10,650	3950 8,550	4000 8,600	2550 5,500	*2250 *4,900	1900 4,150	7240 23'8"
1500 mm 5'0"	kg lb			*8950 *19,250	6650 14,350	*5700 *12,250	3700 7,950	3900 8,350	2450 5,250	*2350 *5,150	1800 3,950	7400 24'3"
0 mm 0'0"	kg lb			*6700 *15,500	6250 13,450	5800 12,450	3500 7,500	3750 8,100	2350 5,050	*2600 *5,750	1800 3,950	7240 23'8"
-1500 mm -5'0"	kg lb	*4500 *10,050	*4500 *10,050	*8250 *17,900	6200 13,300	*5650 *12,200	3400 7,300	3700 8,000	2300 4,950	*3150 *6,900	2000 4,350	6740 22'0"
-3000 mm -10'0"	kg lb	*7950 *17,900	*7950 *17,900	*6300 *13,550	6250 13,450	*4450 *9,550	3400 7,350			*2950 *6,450	2450 5,400	5810 18'10"
-4500 mm -15'0"	kg lb									*2100	*2100	3930



ISO 10567:2007



* Indicates that the load is limited by hydraulic lifting capacity rather than tipping load. The above loads are in compliance with hydraulic excavator lift capacity standard ISO 10567:2007. They do not exceed 87% of hydraulic lifting capacity or 75% of tipping load. Weight of all lifting accessories must be deducted from the above lifting capacities. Lifting capacities are based on the machine standing on a firm, uniform supporting surface. The use of a work tool attachment point to handle/lift objects, could affect the machine lift performance.

Lift capacity stays with ±5% for all available track shoes.

Always refer to the appropriate Operation and Maintenance Manual for specific product information.

315 GC Hydraulic Excavator Specifications

Reach Boom Lift Capacities – Counterweight: 3.83 mt (8,440 lb) – without Bucket

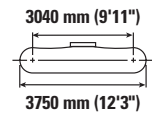
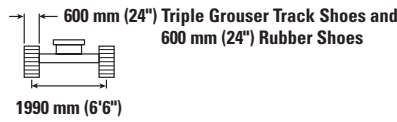
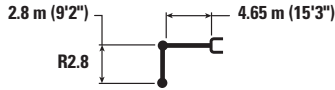

Reach mm ft/in	Unit	1500 mm (5'0")		3000 mm (10'0")		4500 mm (15'0")		6000 mm (20'0")		3040 mm (9'11") 3750 mm (12'3")		mm ft/in
7500 mm 25'0"	kg lb									*2850 *6,500	*2850 *6,500	4210 13'2"
6000 mm 20'0"	kg lb					*3700 *8,100	*3700 *8,100			*2400 *5,250	*2400 *5,250	5830 18'10"
4500 mm 15'0"	kg lb					*4000 *8,700	*4000 *8,700	*3600 *7,650	2650 5,650	*2250 *4,900	2150 4,750	6750 22'0"
3000 mm 10'0"	kg lb			*6850 *14,750	*6850 *14,750	*4900 *10,650	3950 8,450	4000 8,550	2550 5,450	*2250 *4,900	1900 4,150	7240 23'8"
1500 mm 5'0"	kg lb			*8950 *19,250	6600 14,250	*5700 *12,250	3650 7,900	3850 8,250	2450 5,200	*2350 *5,150	1800 3,900	7400 24'3"
0 mm 0'0"	kg lb			*6700 *15,500	6200 13,350	5750 12,350	3450 7,450	3750 8,050	2350 5,000	*2600 *5,750	1800 3,950	7240 23'8"
-1500 mm -5'0"	kg lb	*4500 *10,050	*4500 *10,050	*8250 *17,900	6150 13,150	5650 12,100	3350 7,250	3700 7,900	2300 4,900	*3150 *6,900	1950 4,300	6740 22'0"
-3000 mm -10'0"	kg lb	*7950 *17,900	*7950 *17,900	*6300 *13,550	6200 13,350	*4450 *9,550	3400 7,300			*2950 *6,450	2400 5,350	5810 18'10"
-4500 mm -15'0"	kg lb									*2100	*2100	3930

Reach Boom Lift Capacities – Counterweight: 3.83 mt (8,440 lb) – without Bucket

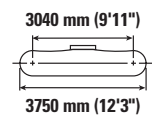
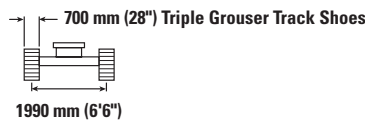
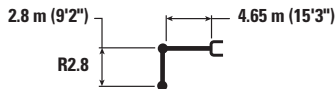

Reach mm ft/in	Unit	1500 mm (5'0")		3000 mm (10'0")		4500 mm (15'0")		6000 mm (20'0")		3040 mm (9'11") 3750 mm (12'3")		mm ft/in
7500 mm 25'0"	kg lb									*2850 *6,500	*2850 *6,500	4210 13'2"
6000 mm 20'0"	kg lb					*3700 *8,100	*3700 *8,100			*2400 *5,250	*2400 *5,250	5830 18'10"
4500 mm 15'0"	kg lb					*4000 *8,700	*4000 *8,700	*3600 *7,650	2650 5,700	*2250 *4,900	2200 4,800	6750 22'0"
3000 mm 10'0"	kg lb			*6850 *14,750	*6850 *14,750	*4900 *10,650	4000 8,550	4050 8,650	2600 5,550	*2250 *4,900	1900 4,200	7240 23'8"
1500 mm 5'0"	kg lb			*8950 *19,250	6700 14,400	*5700 *12,250	3700 8,000	3900 8,350	2450 5,300	*2350 *5,150	1800 3,950	7400 24'3"
0 mm 0'0"	kg lb			*6700 *15,500	6300 13,500	5850 12,500	3500 7,550	3800 8,150	2350 5,050	*2600 *5,750	1800 4,000	7240 23'8"
-1500 mm -5'0"	kg lb	*4500 *10,050	*4500 *10,050	*8250 *17,900	6200 13,350	*5650 *12,200	3400 7,350	3750 8,050	2300 4,950	*3150 *6,900	2000 4,400	6740 22'0"
-3000 mm -10'0"	kg lb	*7950 *17,900	*7950 *17,900	*6300 *13,550	6300 13,500	*4450 *9,550	3450 7,400			*2950 *6,450	2450 5,450	5810 18'10"
-4500 mm -15'0"	kg lb									*2100	*2100	3930



ISO 10567:2007



* Indicates that the load is limited by hydraulic lifting capacity rather than tipping load. The above loads are in compliance with hydraulic excavator lift capacity standard ISO 10567:2007. They do not exceed 87% of hydraulic lifting capacity or 75% of tipping load. Weight of all lifting accessories must be deducted from the above lifting capacities. Lifting capacities are based on the machine standing on a firm, uniform supporting surface. The use of a work tool attachment point to handle/lift objects, could affect the machine lift performance.

Lift capacity stays with ±5% for all available track shoes.

Always refer to the appropriate Operation and Maintenance Manual for specific product information.

315 GC Hydraulic Excavator Specifications

Reach Boom Lift Capacities – Counterweight: 3.83 mt (8,440 lb) – without Bucket

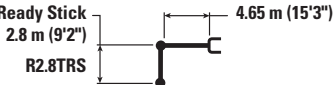

Thumb Ready Stick
2.8 m (9'2")
R2.8TRS

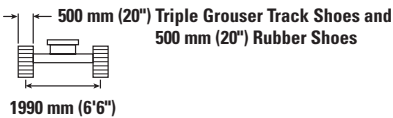





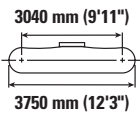



500 mm (20") Triple Grouser Track Shoes and
500 mm (20") Rubber Shoes

1990 mm (6'6")



3040 mm (9'11")
3750 mm (12'3")

		1500 mm (5'0")		3000 mm (10'0")		4500 mm (15'0")		6000 mm (20'0")				mm ft/in
												
7500 mm 25'0"	kg lb									*2850 *6,400	*2850 *6,400	4210 13'2"
6000 mm 20'0"	kg lb					*3700 *8,050	*3700 *8,050			*2350 *5,200	*2350 *5,200	5830 18'10"
4500 mm 15'0"	kg lb					*3950 *8,650	*3950 *8,650	*3600 *7,600	2600 5,500	*2200 *4,850	2100 4,650	6750 22'0"
3000 mm 10'0"	kg lb			*6800 *14,600	*6800 *14,600	*4850 *10,550	3900 8,350	3900 8,400	2500 5,350	*2200 *4,850	1850 4,000	7240 23'8"
1500 mm 5'0"	kg lb			*8850 *19,100	6500 14,000	*5600 *12,150	3600 7,750	3800 8,100	2350 5,100	*2350 *5,100	1700 3,750	7400 24'3"
0 mm 0'0"	kg lb			*6650 *15,450	6100 13,050	5650 12,150	3400 7,250	3650 7,850	2250 4,850	*2600 *5,700	1750 3,800	7240 23'8"
-1500 mm -5'0"	kg lb	*4450 *10,000	*4450 *10,000	*8150 *17,700	6000 12,900	5550 11,900	3300 7,050	3600 7,750	2200 4,750	3100 6,750	1900 4,200	6740 22'0"
-3000 mm -10'0"	kg lb	*7950 *17,850	*7950 *17,850	*6250 *13,400	6100 13,050	*4400 *9,400	3300 7,100			*2900 *6,300	2350 5,250	5810 18'10"
-4500 mm -15'0"	kg lb									*2050	*2050	3930

Reach Boom Lift Capacities – Counterweight: 3.83 mt (8,440 lb) – without Bucket

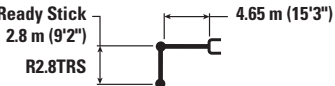

Thumb Ready Stick
2.8 m (9'2")
R2.8TRS

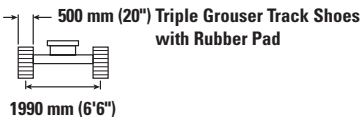





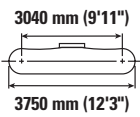

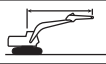

500 mm (20") Triple Grouser Track Shoes
with Rubber Pad

1990 mm (6'6")



3040 mm (9'11")
3750 mm (12'3")

		1500 mm (5'0")		3000 mm (10'0")		4500 mm (15'0")		6000 mm (20'0")				mm ft/in
												
7500 mm 25'0"	kg lb									*2850 *6,400	*2850 *6,400	4210 13'2"
6000 mm 20'0"	kg lb					*3700 *8,050	*3700 *8,050			*2350 *5,200	*2350 *5,200	5830 18'10"
4500 mm 15'0"	kg lb					*3950 *8,650	*3950 *8,650	*3600 *7,600	2650 5,650	*2200 *4,850	2150 4,750	6750 22'0"
3000 mm 10'0"	kg lb			*6800 *14,600	*6800 *14,350	*4850 *10,550	3950 8,550	*4000 8,600	2550 5,500	*2200 *4,850	1900 4,150	7240 23'8"
1500 mm 5'0"	kg lb			*8850 *19,100	6650 14,350	*5600 *12,150	3700 7,950	3900 8,350	2450 5,250	*2350 *5,100	1800 3,900	7400 24'3"
0 mm 0'0"	kg lb			*6650 *15,450	6250 13,450	5800 12,450	3500 7,450	3750 8,100	2350 5,000	*2600 *5,700	1800 3,950	7240 23'8"
-1500 mm -5'0"	kg lb	*4450 *10,000	*4450 *10,000	*8150 *17,700	6200 13,250	*5600 *12,100	3400 7,250	3700 8,000	2300 4,900	*3100 *6,850	1950 4,300	6740 22'0"
-3000 mm -10'0"	kg lb	*7950 *17,850	*7950 *17,850	*6250 *13,400	*6250 *13,400	*4400 *9,400	3400 7,300			*2900 *6,300	2450 5,400	5810 18'10"
-4500 mm -15'0"	kg lb									*2050	*2050	3930



ISO 10567:2007



* Indicates that the load is limited by hydraulic lifting capacity rather than tipping load. The above loads are in compliance with hydraulic excavator lift capacity standard ISO 10567:2007. They do not exceed 87% of hydraulic lifting capacity or 75% of tipping load. Weight of all lifting accessories must be deducted from the above lifting capacities. Lifting capacities are based on the machine standing on a firm, uniform supporting surface. The use of a work tool attachment point to handle/lift objects, could affect the machine lift performance.

Lift capacity stays with ±5% for all available track shoes.

Always refer to the appropriate Operation and Maintenance Manual for specific product information.

315 GC Hydraulic Excavator Specifications

Reach Boom Lift Capacities – Counterweight: 3.83 mt (8,440 lb) – without Bucket

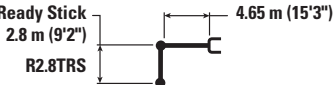



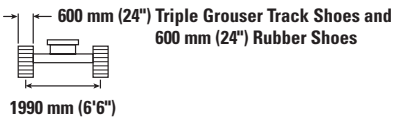



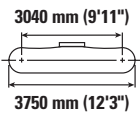

Thumb Ready Stick
2.8 m (9'2")
R2.8TRS



600 mm (24") Triple Grouser Track Shoes and
600 mm (24") Rubber Shoes
1990 mm (6'6")



3040 mm (9'11")
3750 mm (12'3")

		1500 mm (5'0")		3000 mm (10'0")		4500 mm (15'0")		6000 mm (20'0")		 mm ft/in		
												
7500 mm 25'0"	kg lb									*2850 *6,400	*2850 *6,400	4210 13'2"
6000 mm 20'0"	kg lb					*3700 *8,050	*3700 *8,050			*2350 *5,200	*2350 *5,200	5830 18'10"
4500 mm 15'0"	kg lb					*3950 *8,650	*3950 *8,650	*3600 *7,600	2600 5,600	*2200 *4,850	2150 4,700	6750 22'0"
3000 mm 10'0"	kg lb			*6800 *14,600	*6800 *14,600	*4850 *10,550	3950 8,450	4000 8,550	2550 5,450	*2200 *4,850	1850 4,100	7240 23'8"
1500 mm 5'0"	kg lb			*8850 *19,100	6600 14,250	*5600 *12,150	3650 7,850	3850 8,250	2400 5,200	*2350 *5,100	1750 3,850	7400 24'3"
0 mm 0'0"	kg lb			*6650 *15,450	6200 13,300	5750 12,350	3450 7,400	3750 8,000	2300 4,950	*2600 *5,700	1800 3,900	7240 23'8"
-1500 mm -5'0"	kg lb	*4450 *10,000	*4450 *10,000	*8150 *17,700	6100 13,150	*5600 *12,100	3350 7,200	3700 7,900	2250 4,850	*3100 *6,850	1950 4,250	6740 22'0"
-3000 mm -10'0"	kg lb	*7950 *17,850	*7950 *17,850	*6250 *13,400	6200 13,300	*4400 *9,400	3350 7,250			*2900 *6,300	2400 5,350	5810 18'10"
-4500 mm -15'0"	kg lb									*2050	*2050	3930

Reach Boom Lift Capacities – Counterweight: 3.83 mt (8,440 lb) – without Bucket

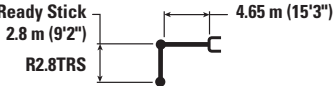



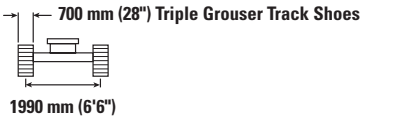



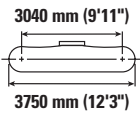

Thumb Ready Stick
2.8 m (9'2")
R2.8TRS

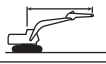

700 mm (28") Triple Grouser Track Shoes
1990 mm (6'6")



3040 mm (9'11")
3750 mm (12'3")

		1500 mm (5'0")		3000 mm (10'0")		4500 mm (15'0")		6000 mm (20'0")		 mm ft/in		
												
7500 mm 25'0"	kg lb									*2850 *6,400	*2850 *6,400	4210 13'2"
6000 mm 20'0"	kg lb					*3700 *8,050	*3700 *8,050			*2350 *5,200	*2350 *5,200	5830 18'10"
4500 mm 15'0"	kg lb					*3950 *8,650	*3950 *8,650	*3600 *7,600	2650 5,700	*2200 *4,850	2150 4,800	6750 22'0"
3000 mm 10'0"	kg lb			*6800 *14,600	*6800 *14,600	*4850 *10,550	4000 8,550	*4000 *8,650	2550 5,500	*2200 *4,850	1900 4,150	7240 23'8"
1500 mm 5'0"	kg lb			*8850 *19,100	6700 14,400	*5600 *12,150	3700 7,950	3900 8,350	2450 5,250	*2350 *5,100	1800 3,900	7400 24'3"
0 mm 0'0"	kg lb			*6650 *15,450	6300 13,500	5850 12,500	3500 7,500	3800 8,150	2350 5,050	*2600 *5,700	1800 3,950	7240 23'8"
-1500 mm -5'0"	kg lb	*4450 *10,000	*4450 *10,000	*8150 *17,700	6200 13,300	*5600 *12,100	3400 7,300	3750 8,000	2300 4,950	*3100 *6,850	2000 4,350	6740 22'0"
-3000 mm -10'0"	kg lb	*7950 *17,850	*7950 *17,850	*6250 *13,400	6250 *13,400	*4400 *9,400	3400 7,350			*2900 *6,300	2450 5,400	5810 18'10"
-4500 mm -15'0"	kg lb									*2050	*2050	3930



ISO 10567:2007



* Indicates that the load is limited by hydraulic lifting capacity rather than tipping load. The above loads are in compliance with hydraulic excavator lift capacity standard ISO 10567:2007. They do not exceed 87% of hydraulic lifting capacity or 75% of tipping load. Weight of all lifting accessories must be deducted from the above lifting capacities. Lifting capacities are based on the machine standing on a firm, uniform supporting surface. The use of a work tool attachment point to handle/lift objects, could affect the machine lift performance.

Lift capacity stays with ±5% for all available track shoes.

Always refer to the appropriate Operation and Maintenance Manual for specific product information.

315 GC Hydraulic Excavator Specifications

Reach Boom Lift Capacities – Counterweight: 3.83 mt (8,440 lb) – without Bucket

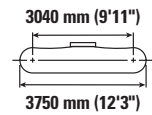
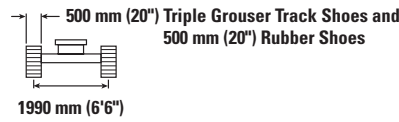
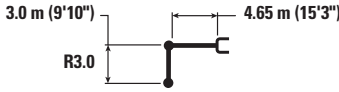

		1500 mm (5'0")		3000 mm (10'0")		4500 mm (15'0")		6000 mm (20'0")		7500 mm (25'0")		mm ft/in		
7500 mm 25'0"	kg lb					*2700	*2700					*2600 *5,850	*2600 *5,850	4540 14'3"
6000 mm 20'0"	kg lb					*3450 *7,550	*3450 *7,550	*2400	*2400			*2200 *4,850	*2200 *4,850	6070 19'8"
4500 mm 15'0"	kg lb					*3650 *7,950	*3650 *7,950	*3450 *7,400	2600 5,600			*2050 *4,500	2000 4,450	6960 22'8"
3000 mm 10'0"	kg lb			*5850 *12,100	*5850 *12,100	*4800 *10,350	3900 8,400	3950 8,400	2500 5,400			*2050 *4,500	1800 3,900	7440 24'4"
1500 mm 5'0"	kg lb			*8750 *18,800	6600 14,150	*5600 *12,050	3650 7,800	3800 8,150	2400 5,150	*2500 1700		*2150 *4,750	1700 3,700	7590 24'10"
0 mm 0'0"	kg lb			*7000 *16,150	6150 13,150	5650 12,150	3400 7,350	3650 7,900	2300 4,900			*2400 *5,250	1700 3,700	7430 24'4"
-1500 mm -5'0"	kg lb	*4300 *9,650	*4300 *9,650	*8500 *18,350	6000 12,900	5550 11,900	3300 7,100	3600 7,750	2250 4,800			*2850 *6,250	1850 4,050	6940 22'8"
-3000 mm -10'0"	kg lb	*7450 *16,700	*7450 *16,700	*6650 *14,350	6050 13,000	*4700 *10,000	3300 7,100	*3000	2250			*2950 *6,400	2250 4,950	6050 19'8"
-4500 mm -15'0"	kg lb			*3450 *7,050	*3450 *7,050							*2050 *4,250	*2050 *4,250	4490 14'4"

Reach Boom Lift Capacities – Counterweight: 3.83 mt (8,440 lb) – without Bucket

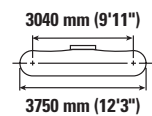
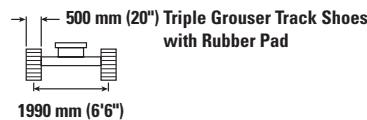
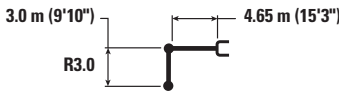

		1500 mm (5'0")		3000 mm (10'0")		4500 mm (15'0")		6000 mm (20'0")		7500 mm (25'0")		mm ft/in		
7500 mm 25'0"	kg lb					*2700	*2700					*2600 *5,850	*2600 *5,850	4540 14'3"
6000 mm 20'0"	kg lb					*3450 *7,550	*3450 *7,550	*2400	*2400			*2200 *4,850	*2200 *4,850	6070 19'8"
4500 mm 15'0"	kg lb					*3650 *7,950	*3650 *7,950	*3450 *7,400	2650 5,700			*2050 *4,500	*2050 *4,500	6960 22'8"
3000 mm 10'0"	kg lb			*5850 *12,100	*5850 *12,100	*4800 *10,350	4000 8,600	*3950 *8,550	2600 5,550			*2050 *4,500	1850 4,000	7440 24'4"
1500 mm 5'0"	kg lb			*8750 *18,800	6750 14,550	*5600 *12,050	3750 8,000	3900 8,350	2450 5,300	*2500 1750		*2150 *4,750	1750 3,800	7590 24'10"
0 mm 0'0"	kg lb			*7000 *16,150	6300 13,500	5800 12,500	3500 7,550	3800 8,100	2350 5,050			*2400 *5,250	1750 3,800	7430 24'4"
-1500 mm -5'0"	kg lb	*4300 *9,650	*4300 *9,650	*8500 *18,350	6200 13,250	5700 12,200	3400 7,300	3700 8,000	2300 4,950			*2850 *6,250	1900 4,150	6940 22'8"
-3000 mm -10'0"	kg lb	*7450 *16,700	*7450 *16,700	*6650 *14,350	6250 13,400	*4700 *10,000	3400 7,300	*3000	2350			*2950 *6,400	2300 5,100	6050 19'8"
-4500 mm -15'0"	kg lb			*3450 *7,050	*3450 *7,050							*2050 *4,250	*2050 *4,250	4490 14'4"



ISO 10567:2007



* Indicates that the load is limited by hydraulic lifting capacity rather than tipping load. The above loads are in compliance with hydraulic excavator lift capacity standard ISO 10567:2007. They do not exceed 87% of hydraulic lifting capacity or 75% of tipping load. Weight of all lifting accessories must be deducted from the above lifting capacities. Lifting capacities are based on the machine standing on a firm, uniform supporting surface. The use of a work tool attachment point to handle/lift objects, could affect the machine lift performance.

Lift capacity stays with ±5% for all available track shoes.

Always refer to the appropriate Operation and Maintenance Manual for specific product information.

315 GC Hydraulic Excavator Specifications

Reach Boom Lift Capacities – Counterweight: 3.83 mt (8,440 lb) – without Bucket

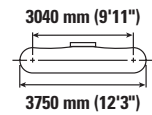
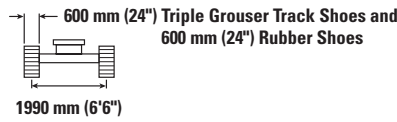
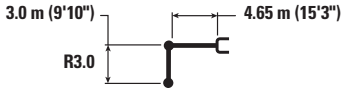

		1500 mm (5'0")		3000 mm (10'0")		4500 mm (15'0")		6000 mm (20'0")		7500 mm (25'0")		mm ft/in		
7500 mm 25'0"	kg lb					*2700	*2700					*2600 *5,850	*2600 *5,850	4540 14'3"
6000 mm 20'0"	kg lb					*3450 *7,550	*3450 *7,550	*2400	*2400			*2200 *4,850	*2200 *4,850	6070 19'8"
4500 mm 15'0"	kg lb					*3650 *7,950	*3650 *7,950	*3450 *7,400	2650 5,650			*2050 *4,500	2050 4,500	6960 22'8"
3000 mm 10'0"	kg lb			*5850 *12,100	*5850 *12,100	*4800 *10,350	3950 8,550	*3950 *8,550	2550 5,500			*2050 *4,500	1800 4,000	7440 24'4"
1500 mm 5'0"	kg lb			*8750 *18,800	6700 14,400	*5600 *12,050	3700 7,950	3850 8,300	2450 5,250	*2500	1750	*2150 *4,750	1700 3,750	7590 24'10"
0 mm 0'0"	kg lb			*7000 *16,150	6250 13,400	5750 12,350	3450 7,450	3750 8,050	2350 5,000			*2400 *5,250	1750 3,800	7430 24'4"
-1500 mm -5'0"	kg lb	*4300 *9,650	*4300 *9,650	*8500 *18,350	6150 13,150	5650 12,100	3350 7,250	3700 7,900	2300 4,900			*2850 *6,250	1900 4,150	6940 22'8"
-3000 mm -10'0"	kg lb	*7450 *16,700	*7450 *16,700	*6650 *14,350	6200 13,250	*4700 *10,000	3350 7,250	*3000	2300			*2950 *6,400	2300 5,050	6050 19'8"
-4500 mm -15'0"	kg lb			*3450 *7,050	*3450 *7,050							*2050 *4,250	*2050 *4,250	4490 14'4"

Reach Boom Lift Capacities – Counterweight: 3.83 mt (8,440 lb) – without Bucket

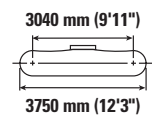
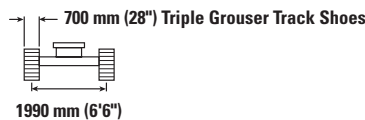
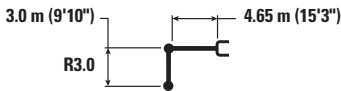

		1500 mm (5'0")		3000 mm (10'0")		4500 mm (15'0")		6000 mm (20'0")		7500 mm (25'0")		mm ft/in		
7500 mm 25'0"	kg lb					*2700	*2700					*2600 *5,850	*2600 *5,850	4540 14'3"
6000 mm 20'0"	kg lb					*3450 *7,550	*3450 *7,550	*2400	*2400			*2200 *4,850	*2200 *4,850	6070 19'8"
4500 mm 15'0"	kg lb					*3650 *7,950	*3650 *7,950	*3450 *7,400	2700 5,750			*2050 *4,500	*2050 *4,500	6960 22'8"
3000 mm 10'0"	kg lb			*5850 *12,100	*5850 *12,100	*4800 *10,350	4000 8,650	*3950 *8,550	2600 5,550			*2050 *4,500	1850 4,050	7440 24'4"
1500 mm 5'0"	kg lb			*8750 *18,800	6800 14,600	*5600 *12,050	3750 8,050	3900 8,400	2450 5,300	*2500	1750	*2150 *4,750	1750 3,800	7590 24'10"
0 mm 0'0"	kg lb			*7000 *16,150	6350 13,600	5850 12,550	3500 7,550	3800 8,150	2350 5,100			*2400 *5,250	1750 3,850	7430 24'4"
-1500 mm -5'0"	kg lb	*4300 *9,650	*4300 *9,650	*8500 *18,350	6200 13,300	5700 12,250	3400 7,350	3750 8,000	2300 4,950			*2850 *6,250	1900 4,200	6940 22'8"
-3000 mm -10'0"	kg lb	*7450 *16,700	*7450 *16,700	*6650 *14,350	6250 13,450	*4700 *10,000	3400 7,350	*3000	2350			*2950 *6,400	2300 5,100	6050 19'8"
-4500 mm -15'0"	kg lb			*3450 *7,050	*3450 *7,050							*2050 *4,250	*2050 *4,250	4490 14'4"



ISO 10567:2007



* Indicates that the load is limited by hydraulic lifting capacity rather than tipping load. The above loads are in compliance with hydraulic excavator lift capacity standard ISO 10567:2007. They do not exceed 87% of hydraulic lifting capacity or 75% of tipping load. Weight of all lifting accessories must be deducted from the above lifting capacities. Lifting capacities are based on the machine standing on a firm, uniform supporting surface. The use of a work tool attachment point to handle/lift objects, could affect the machine lift performance.

Lift capacity stays with ±5% for all available track shoes.

Always refer to the appropriate Operation and Maintenance Manual for specific product information.

315 GC Hydraulic Excavator Specifications

Reach Boom Lift Capacities – Counterweight: 3.83 mt (8,440 lb) – without Bucket – Blade Up

2500 mm (8'2") Blade

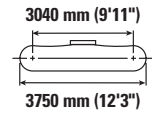
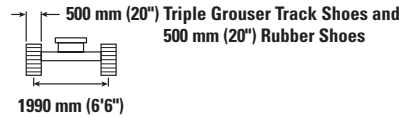
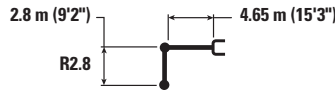

Reach Boom Length	Unit	1500 mm (5'0")		3000 mm (10'0")		4500 mm (15'0")		6000 mm (20'0")		2500 mm (8'2") Blade		mm ft/in
		Hydraulic	Tipping	Hydraulic	Tipping	Hydraulic	Tipping	Hydraulic	Tipping	Hydraulic	Tipping	
7500 mm 25'0"	kg lb									*2850 *6,500	*2850 *6,500	4210 13'2"
6000 mm 20'0"	kg lb					*3700 *8,100	*3700 *8,100			*2400 *5,250	*2400 *5,250	5830 18'10"
4500 mm 15'0"	kg lb					*4000 *8,700	*4000 *8,700	*3600 *7,650	2700 5,800	*2250 *4,900	*2250 4,900	6750 22'0"
3000 mm 10'0"	kg lb			*6850 *14,750	*6850 *14,750	*4900 *10,650	4050 8,700	3900 8,350	2600 5,600	*2250 *4,900	2200 4,900	7240 23'8"
1500 mm 5'0"	kg lb			*8950 *19,250	6800 14,600	*5700 *12,250	3750 8,100	3750 8,100	2500 5,350	*2350 *5,150	1850 4,000	7400 24'3"
0 mm 0'0"	kg lb			*6700 *15,500	6400 13,750	5650 12,100	3550 7,650	3650 7,850	2400 5,150	*2600 *5,750	1850 4,050	7240 23'8"
-1500 mm -5'0"	kg lb	*4500 *10,050	*4500 *10,050	*8250 *17,900	6300 13,550	5500 11,850	3450 7,450	3600 7,750	2350 5,050	3050 6,750	2050 4,450	6740 22'0"
-3000 mm -10'0"	kg lb	*7950 *17,900	*7950 *17,900	*6300 *13,550	*6300 *13,550	*4450 *9,550	3500 7,500			*2950 *6,450	2500 5,550	5810 18'10"
-4500 mm -15'0"	kg lb									*2100 *2100	*2100 *2100	3930

Reach Boom Lift Capacities – Counterweight: 3.83 mt (8,440 lb) – without Bucket – Blade Up

2500 mm (8'2") Blade

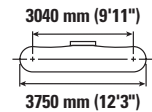
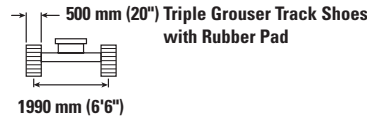
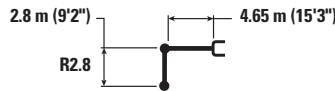

Reach Boom Length	Unit	1500 mm (5'0")		3000 mm (10'0")		4500 mm (15'0")		6000 mm (20'0")		2500 mm (8'2") Blade		mm ft/in
		Hydraulic	Tipping	Hydraulic	Tipping	Hydraulic	Tipping	Hydraulic	Tipping	Hydraulic	Tipping	
7500 mm 25'0"	kg lb									*2850 *6,500	*2850 *6,500	4210 13'2"
6000 mm 20'0"	kg lb					*3700 *8,100	*3700 *8,100			*2400 *5,250	*2400 *5,250	5830 18'10"
4500 mm 15'0"	kg lb					*4000 *8,700	*4000 *8,700	*3600 *7,650	2750 5,950	*2250 *4,900	*2250 *4,900	6750 22'0"
3000 mm 10'0"	kg lb			*6850 *14,750	*6850 *14,750	*4900 *10,650	4150 8,900	4000 8,600	2700 5,750	*2250 *4,900	2000 4,400	7240 23'8"
1500 mm 5'0"	kg lb			*8950 *19,250	6950 15,000	*5700 *12,250	3850 8,300	3850 8,300	2550 5,500	*2350 *5,150	1900 4,150	7400 24'3"
0 mm 0'0"	kg lb			*6700 *15,500	6550 14,100	5800 12,400	3650 7,850	3750 8,100	2450 5,300	*2600 *5,750	1900 4,200	7240 23'8"
-1500 mm -5'0"	kg lb	*4500 *10,050	*4500 *10,050	*8250 *17,900	6500 13,900	*5650 12,200	3550 7,650	3700 7,950	2400 5,200	*3150 *6,900	2100 4,600	6740 22'0"
-3000 mm -10'0"	kg lb	*7950 *17,900	*7950 *17,900	*6300 *13,550	*6300 *13,550	*4450 *9,550	3600 7,700			*2950 *6,450	2550 5,700	5810 18'10"
-4500 mm -15'0"	kg lb									*2100 *2100	*2100 *2100	3930



ISO 10567:2007



* Indicates that the load is limited by hydraulic lifting capacity rather than tipping load. The above loads are in compliance with hydraulic excavator lift capacity standard ISO 10567:2007. They do not exceed 87% of hydraulic lifting capacity or 75% of tipping load. Weight of all lifting accessories must be deducted from the above lifting capacities. Lifting capacities are based on the machine standing on a firm, uniform supporting surface. The use of a work tool attachment point to handle/lift objects, could affect the machine lift performance.

Lift capacity stays with ±5% for all available track shoes.

Always refer to the appropriate Operation and Maintenance Manual for specific product information.

315 GC Hydraulic Excavator Specifications

Reach Boom Lift Capacities – Counterweight: 3.83 mt (8,440 lb) – without Bucket – Blade Up

2600 mm (8'6") Blade

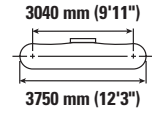
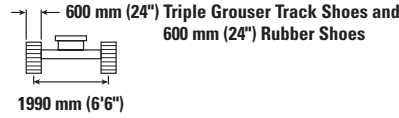
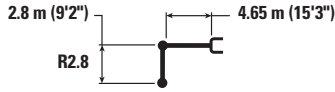

Reach Boom Lift Configuration	1500 mm (5'0")		3000 mm (10'0")		4500 mm (15'0")		6000 mm (20'0")		2600 mm (8'6") Blade		mm ft/in	
	Hydraulic	Tipping	Hydraulic	Tipping	Hydraulic	Tipping	Hydraulic	Tipping	Hydraulic	Tipping		
7500 mm 25'0"	kg lb								*2850 *6,500	*2850 *6,500	4210 13'2"	
6000 mm 20'0"	kg lb				*3700 *8,100	*3700 *8,100			*2400 *5,250	*2400 *5,250	5830 18'10"	
4500 mm 15'0"	kg lb				*4000 *8,700	*4000 *8,700	*3600 *7,650	2750 5,900	*2250 *4,900	*2250 *4,900	6750 22'0"	
3000 mm 10'0"	kg lb			*6850 *14,750	*6850 *14,750	*4900 *10,650	4100 8,850	3950 8,500	2650 5,750	*2250 *4,900	2000 4,350	7240 23'8"
1500 mm 5'0"	kg lb			*8950 *19,250	6950 14,900	*5700 *12,250	3850 8,250	3850 8,200	2550 5,500	*2350 *5,150	1850 4,100	7400 24'3"
0 mm 0'0"	kg lb			*6700 *15,500	6550 14,000	5700 12,300	3650 7,800	3700 8,000	2450 5,250	*2600 *5,750	1900 4,150	7240 23'8"
-1500 mm -5'0"	kg lb	*4500 *10,050	*4500 *10,050	*8250 *17,900	6450 13,850	5600 12,050	3550 7,650	3650 7,900	2400 5,150	*3150 *6,900	2100 4,550	6740 22'0"
-3000 mm -10'0"	kg lb	*7950 *17,900	*7950 *17,900	*6300 *13,550	*6300 *13,550	*4450 *9,550	3550 7,650			*2950 *6,450	2550 5,650	5810 18'10"
-4500 mm -15'0"	kg lb									*2100 *2100		3930

Reach Boom Lift Capacities – Counterweight: 3.83 mt (8,440 lb) – without Bucket – Blade Up

2700 mm (8'10") Blade

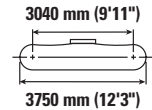
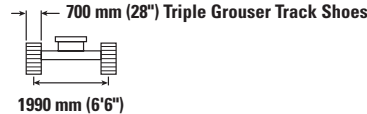
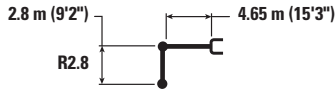

Reach Boom Lift Configuration	1500 mm (5'0")		3000 mm (10'0")		4500 mm (15'0")		6000 mm (20'0")		2700 mm (8'10") Blade		mm ft/in	
	Hydraulic	Tipping	Hydraulic	Tipping	Hydraulic	Tipping	Hydraulic	Tipping	Hydraulic	Tipping		
7500 mm 25'0"	kg lb								*2850 *6,500	*2850 *6,500	4210 13'2"	
6000 mm 20'0"	kg lb				*3700 *8,100	*3700 *8,100			*2400 *5,250	*2400 *5,250	5830 18'10"	
4500 mm 15'0"	kg lb				*4000 *8,700	*4000 *8,700	*3600 *7,650	2800 5,950	*2250 *4,900	*2250 *4,900	6750 22'0"	
3000 mm 10'0"	kg lb			*6850 *14,750	*6850 *14,750	*4900 *10,650	4150 8,950	4000 8,600	2700 5,800	*2250 *4,900	2000 4,400	7240 23'8"
1500 mm 5'0"	kg lb			*8950 *19,250	7000 15,100	*5700 *12,250	3900 8,400	3900 8,350	2600 5,550	*2350 *5,150	1900 4,150	7400 24'3"
0 mm 0'0"	kg lb			*6700 *15,500	6600 14,200	5800 12,450	3700 7,950	3750 8,100	2500 5,350	*2600 *5,750	1900 4,200	7240 23'8"
-1500 mm -5'0"	kg lb	*4500 *10,050	*4500 *10,050	*8250 *17,900	6550 14,050	*5650 *12,200	3600 7,750	3700 8,000	2450 5,250	*3150 *6,900	2100 4,600	6740 22'0"
-3000 mm -10'0"	kg lb	*7950 *17,900	*7950 *17,900	*6300 *13,550	*6300 *13,550	*4450 *9,550	3600 7,800			*2950 *6,450	2600 5,750	5810 18'10"
-4500 mm -15'0"	kg lb									*2100 *2100		3930



ISO 10567:2007



* Indicates that the load is limited by hydraulic lifting capacity rather than tipping load. The above loads are in compliance with hydraulic excavator lift capacity standard ISO 10567:2007. They do not exceed 87% of hydraulic lifting capacity or 75% of tipping load. Weight of all lifting accessories must be deducted from the above lifting capacities. Lifting capacities are based on the machine standing on a firm, uniform supporting surface. The use of a work tool attachment point to handle/lift objects, could affect the machine lift performance.

Lift capacity stays with ±5% for all available track shoes.

Always refer to the appropriate Operation and Maintenance Manual for specific product information.

315 GC Hydraulic Excavator Specifications

Reach Boom Lift Capacities – Counterweight: 3.83 mt (8,440 lb) – without Bucket – Blade Up

2500 mm (8'2") Blade

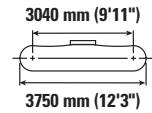
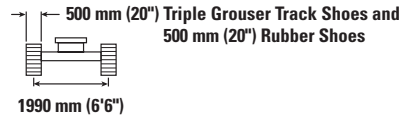
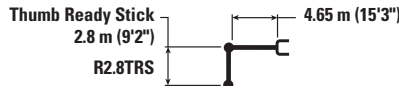

Reach	Unit	1500 mm (5'0")		3000 mm (10'0")		4500 mm (15'0")		6000 mm (20'0")		2500 mm (8'2") Blade		mm ft/in
		Hydraulic	Tipping	Hydraulic	Tipping	Hydraulic	Tipping	Hydraulic	Tipping	Hydraulic	Tipping	
7500 mm 25'0"	kg lb									*2850 *6,400	*2850 *6,400	4210 13'2"
6000 mm 20'0"	kg lb					*3700 *8,050	*3700 *8,050			*2350 *5,200	*2350 *5,200	5830 18'10"
4500 mm 15'0"	kg lb					*3950 *8,650	*3950 *8,650	*3600 *7,600	2700 5,750	*2200 *4,850	*2200 *4,850	6750 22'0"
3000 mm 10'0"	kg lb			*6800 *14,600	*6800 *14,600	*4850 *10,550	4050 8,700	3900 8,350	2600 5,600	*2200 *4,850	1900 4,200	7240 23'8"
1500 mm 5'0"	kg lb			*8850 *19,100	6800 14,600	*5600 *12,150	3750 8,100	3750 8,100	2500 5,350	*2350 *5,100	1800 3,950	7400 24'3"
0 mm 0'0"	kg lb			*6650 *15,450	6400 13,700	5650 12,100	3550 7,600	3650 7,850	2400 5,100	*2600 *5,700	1850 4,000	7240 23'8"
-1500 mm -5'0"	kg lb	*4450 *10,000	*4450 *10,000	*8150 *17,700	6300 13,500	5550 11,850	3450 7,400	3600 7,750	2350 5,000	3050 6,750	2000 4,400	6740 22'0"
-3000 mm -10'0"	kg lb	*7950 *17,850	*7950 *17,850	*6250 *13,400	*6250 *13,400	*4400 *9,400	3500 7,450			*2900 *6,300	2500 5,500	5810 18'10"
-4500 mm -15'0"	kg lb									*2050 *2050	*2050 *2050	3930

Reach Boom Lift Capacities – Counterweight: 3.83 mt (8,440 lb) – without Bucket – Blade Up

2500 mm (8'2") Blade

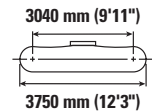
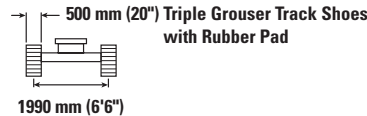
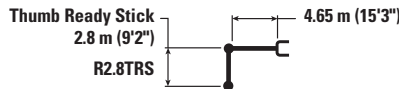

Reach	Unit	1500 mm (5'0")		3000 mm (10'0")		4500 mm (15'0")		6000 mm (20'0")		2500 mm (8'2") Blade		mm ft/in
		Hydraulic	Tipping	Hydraulic	Tipping	Hydraulic	Tipping	Hydraulic	Tipping	Hydraulic	Tipping	
7500 mm 25'0"	kg lb									*2850 *6,400	*2850 *6,400	4210 13'2"
6000 mm 20'0"	kg lb					*3700 *8,050	*3700 *8,050			*2350 *5,200	*2350 *5,200	5830 18'10"
4500 mm 15'0"	kg lb					*3950 *8,650	*3950 *8,650	*3600 *7,600	2750 5,900	*2200 *4,850	*2200 *4,850	6750 22'0"
3000 mm 10'0"	kg lb			*6800 *14,600	*6800 *14,600	*4850 *10,550	4150 8,900	*4000 8,600	2650 5,750	*2200 *4,850	2000 4,350	7240 23'8"
1500 mm 5'0"	kg lb			*8850 *19,100	6950 15,000	*5600 *12,150	3850 8,300	3850 8,300	2550 5,500	*2350 *5,100	1850 4,100	7400 24'3"
0 mm 0'0"	kg lb			*6650 *15,450	6550 14,050	5800 *12,450	3650 7,850	3750 8,050	2450 5,250	*2600 *5,700	1900 4,150	7240 23'8"
-1500 mm -5'0"	kg lb	*4450 *10,000	*4450 *10,000	*8150 *17,700	6500 13,900	*5600 *12,100	3550 7,650	3700 7,950	2400 5,150	*3100 *6,850	2050 4,550	6740 22'0"
-3000 mm -10'0"	kg lb	*7950 *17,850	*7950 *17,850	*6250 *13,400	*6250 *13,400	*4400 *9,400	3550 7,700			*2900 *6,300	2550 5,650	5810 18'10"
-4500 mm -15'0"	kg lb									*2050 *2050	*2050 *2050	3930



ISO 10567:2007



* Indicates that the load is limited by hydraulic lifting capacity rather than tipping load. The above loads are in compliance with hydraulic excavator lift capacity standard ISO 10567:2007. They do not exceed 87% of hydraulic lifting capacity or 75% of tipping load. Weight of all lifting accessories must be deducted from the above lifting capacities. Lifting capacities are based on the machine standing on a firm, uniform supporting surface. The use of a work tool attachment point to handle/lift objects, could affect the machine lift performance.

Lift capacity stays with ±5% for all available track shoes.

Always refer to the appropriate Operation and Maintenance Manual for specific product information.

315 GC Hydraulic Excavator Specifications

Reach Boom Lift Capacities – Counterweight: 3.83 mt (8,440 lb) – without Bucket – Blade Up

2600 mm (8'6") Blade

Thumb Ready Stick
2.8 m (9'2")
R2.8TRS

600 mm (24") Triple Grouser Track Shoes and
600 mm (24") Rubber Shoes

1990 mm (6'6")

3040 mm (9'11")
3750 mm (12'3")

Reach Boom	Unit	1500 mm (5'0")		3000 mm (10'0")		4500 mm (15'0")		6000 mm (20'0")		Blade		mm ft/in
7500 mm 25'0"	kg lb									*2850 *6,400	*2850 *6,400	4210 13'2"
6000 mm 20'0"	kg lb					*3700 *8,050	*3700 *8,050			*2350 *5,200	*2350 *5,200	5830 18'10"
4500 mm 15'0"	kg lb					*3950 *8,650	*3950 *8,650	*3600 *7,600	2750 5,900	*2200 *4,850	*2200 *4,850	6750 22'0"
3000 mm 10'0"	kg lb			*6800 *14,600	*6800 *14,600	*4850 *10,550	4100 8,850	3950 8,500	2650 5,700	*2200 *4,850	1950 4,300	7240 23'8"
1500 mm 5'0"	kg lb			*8850 *19,100	6950 14,900	*5600 *12,150	3850 8,250	3850 8,200	2550 5,450	*2350 *5,100	1850 4,050	7400 24'3"
0 mm 0'0"	kg lb			*6650 *15,450	6500 14,000	5750 12,300	3600 7,800	3700 8,000	2450 5,250	*2600 *5,700	1900 4,100	7240 23'8"
-1500 mm -5'0"	kg lb	*4450 *10,000	*4450 *10,000	*8150 *17,700	6450 13,800	*5600 *12,050	3550 7,600	3650 7,850	2400 5,150	*3100 *6,850	2050 4,500	6740 22'0"
-3000 mm -10'0"	kg lb	*7950 *17,850	*7950 *17,850	*6250 *13,400	*6250 *13,400	*4400 *9,400	3550 7,650			*2900 *6,300	2550 5,600	5810 18'10"
-4500 mm -15'0"	kg lb									*2050	*2050	3930

Reach Boom Lift Capacities – Counterweight: 3.83 mt (8,440 lb) – without Bucket – Blade Up

2700 mm (8'10") Blade

Thumb Ready Stick
2.8 m (9'2")
R2.8TRS

700 mm (28") Triple Grouser Track Shoes

1990 mm (6'6")

3040 mm (9'11")
3750 mm (12'3")

Reach Boom	Unit	1500 mm (5'0")		3000 mm (10'0")		4500 mm (15'0")		6000 mm (20'0")		Blade		mm ft/in
7500 mm 25'0"	kg lb									*2850 *6,400	*2850 *6,400	4210 13'2"
6000 mm 20'0"	kg lb					*3700 *8,050	*3700 *8,050			*2350 *5,200	*2350 *5,200	5830 18'10"
4500 mm 15'0"	kg lb					*3950 *8,650	*3950 *8,650	*3600 *7,600	2800 5,950	*2200 *4,850	*2200 *4,850	6750 22'0"
3000 mm 10'0"	kg lb			*6800 *14,600	*6800 *14,600	*4850 *10,550	4150 8,950	*4000 8,600	2700 5,800	*2200 *4,850	2000 4,400	7240 23'8"
1500 mm 5'0"	kg lb			*8850 *19,100	7000 15,100	*5600 *12,150	3900 8,350	3900 8,350	2600 5,500	*2350 *5,100	1900 4,100	7400 24'3"
0 mm 0'0"	kg lb			*6650 *15,450	6600 14,200	5800 12,450	3650 7,900	3750 8,100	2450 5,300	*2600 *5,700	1900 4,150	7240 23'8"
-1500 mm -5'0"	kg lb	*4450 *10,000	*4450 *10,000	*8150 *17,700	6550 14,000	*5600 *12,100	3600 7,700	3700 8,000	2400 5,200	*3100 *6,850	2100 4,600	6740 22'0"
-3000 mm -10'0"	kg lb	*7950 *17,850	*7950 *17,850	*6250 *13,400	*6250 *13,400	*4400 *9,400	3600 7,750			*2900 *6,300	2600 5,700	5810 18'10"
-4500 mm -15'0"	kg lb									*2050	*2050	3930



ISO 10567:2007



* Indicates that the load is limited by hydraulic lifting capacity rather than tipping load. The above loads are in compliance with hydraulic excavator lift capacity standard ISO 10567:2007. They do not exceed 87% of hydraulic lifting capacity or 75% of tipping load. Weight of all lifting accessories must be deducted from the above lifting capacities. Lifting capacities are based on the machine standing on a firm, uniform supporting surface. The use of a work tool attachment point to handle/lift objects, could affect the machine lift performance.

Lift capacity stays with ±5% for all available track shoes.

Always refer to the appropriate Operation and Maintenance Manual for specific product information.

315 GC Hydraulic Excavator Specifications

Reach Boom Lift Capacities – Counterweight: 3.83 mt (8,440 lb) – without Bucket – Blade Up

2500 mm (8'2") Blade

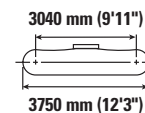
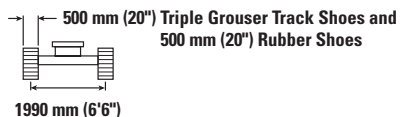

		1500 mm (5'0")		3000 mm (10'0")		4500 mm (15'0")		6000 mm (20'0")		7500 mm (25'0")		mm ft/in		
7500 mm 25'0"	kg lb					*2700 *2700	*2700 *2700					*2600 *5,850	*2600 *5,850	4540 14'3"
6000 mm 20'0"	kg lb					*3450 *7,550	*3450 *7,550	*2400 *2400	*2400 *2400			*2200 *4,850	*2200 *4,850	6070 19'8"
4500 mm 15'0"	kg lb					*3650 *7,950	*3650 *7,950	*3450 *7,400	2700 5,850			*2050 *4,500	*2050 *4,500	6960 22'8"
3000 mm 10'0"	kg lb			*5850 *12,100	*5850 *12,100	*4800 *10,350	4100 8,750	3900 8,400	2650 5,650			*2050 *4,500	1850 4,100	7440 24'4"
1500 mm 5'0"	kg lb			*8750 *18,800	6900 14,800	*5600 *12,050	3800 8,150	3800 8,100	2500 5,400	*2500 1800		*2150 *4,750	1750 3,850	7590 24'10"
0 mm 0'0"	kg lb			*7000 *16,150	6450 13,800	5650 12,100	3600 7,700	3650 7,850	2400 5,150			*2400 *5,250	1800 3,900	7430 24'4"
-1500 mm -5'0"	kg lb	*4300 *9,650	*4300 *9,650	*8500 *18,350	6300 13,550	5500 11,850	3450 7,450	3600 7,750	2350 5,050			*2850 *6,250	1950 4,250	6940 22'8"
-3000 mm -10'0"	kg lb	*7450 *16,700	*7450 *16,700	*6650 *14,350	6350 13,650	*4700 *10,000	3450 7,450	*3000 6,600	2350 5,200			*2950 *6,400	2350 5,200	6050 19'8"
-4500 mm -15'0"	kg lb			*3450 *7,050	*3450 *7,050							*2050 *4,250	*2050 *4,250	4490 14'4"

Reach Boom Lift Capacities – Counterweight: 3.83 mt (8,440 lb) – without Bucket – Blade Up

2500 mm (8'2") Blade

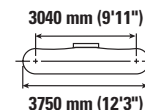
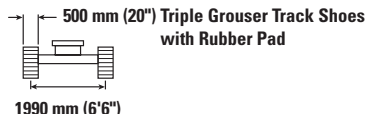

		1500 mm (5'0")		3000 mm (10'0")		4500 mm (15'0")		6000 mm (20'0")		7500 mm (25'0")		mm ft/in		
7500 mm 25'0"	kg lb					*2700 *2700	*2700 *2700					*2600 *5,850	*2600 *5,850	4540 14'3"
6000 mm 20'0"	kg lb					*3450 *7,550	*3450 *7,550	*2400 *2400	*2400 *2400			*2200 *4,850	*2200 *4,850	6070 19'8"
4500 mm 15'0"	kg lb					*3650 *7,950	*3650 *7,950	*3450 *7,400	2800 5,950			*2050 *4,500	*2050 *4,500	6960 22'8"
3000 mm 10'0"	kg lb			*5850 *12,100	*5850 *12,100	*4800 *10,350	4150 8,950	*3950 *8,550	2700 5,800			*2050 *4,500	1900 4,200	7440 24'4"
1500 mm 5'0"	kg lb			*8750 *18,800	7050 15,200	*5600 *12,050	3900 8,350	3900 8,350	2600 5,550	*2500 1850		*2150 *4,750	1800 4,000	7590 24'10"
0 mm 0'0"	kg lb			*7000 *16,150	6600 14,150	5800 12,450	3650 7,900	3750 8,100	2450 5,300			*2400 *5,250	1850 4,000	7430 24'4"
-1500 mm -5'0"	kg lb	*4300 *9,650	*4300 *9,650	*8500 *18,350	6500 13,900	5700 12,200	3550 7,650	3700 7,950	2400 5,200			*2850 *6,250	2000 4,400	6940 22'8"
-3000 mm -10'0"	kg lb	*7450 *16,700	*7450 *16,700	*6650 *14,350	6550 14,000	*4700 *10,000	3550 7,650	*3000 6,600	2450 5,350			*2950 *6,400	2400 5,350	6050 19'8"
-4500 mm -15'0"	kg lb			*3450 *7,050	*3450 *7,050							*2050 *4,250	*2050 *4,250	4490 14'4"



ISO 10567:2007



* Indicates that the load is limited by hydraulic lifting capacity rather than tipping load. The above loads are in compliance with hydraulic excavator lift capacity standard ISO 10567:2007. They do not exceed 87% of hydraulic lifting capacity or 75% of tipping load. Weight of all lifting accessories must be deducted from the above lifting capacities. Lifting capacities are based on the machine standing on a firm, uniform supporting surface. The use of a work tool attachment point to handle/lift objects, could affect the machine lift performance.

Lift capacity stays with ±5% for all available track shoes.

Always refer to the appropriate Operation and Maintenance Manual for specific product information.

315 GC Hydraulic Excavator Specifications

Reach Boom Lift Capacities – Counterweight: 3.83 mt (8,440 lb) – without Bucket – Blade Up

2600 mm (8'6") Blade

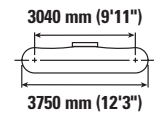
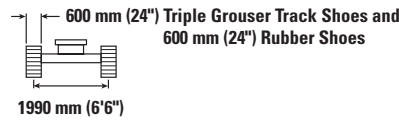
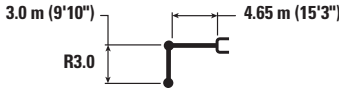

		1500 mm (5'0")		3000 mm (10'0")		4500 mm (15'0")		6000 mm (20'0")		7500 mm (25'0")		mm ft/in		
7500 mm 25'0"	kg lb					*2700	*2700					*2600 *5,850	*2600 *5,850	4540 14'3"
6000 mm 20'0"	kg lb					*3450 *7,550	*3450 *7,550	*2400	*2400			*2200 *4,850	*2200 *4,850	6070 19'8"
4500 mm 15'0"	kg lb					*3650 *7,950	*3650 *7,950	*3450 *7,400	2800 5,950			*2050 *4,500	*2050 *4,500	6960 22'8"
3000 mm 10'0"	kg lb			*5850 *12,100	*5850 *12,100	*4800 *10,350	4150 8,950	*3950 8,550	2700 5,750			*2050 *4,500	1900 4,200	7440 24'4"
1500 mm 5'0"	kg lb			*8750 *18,800	7000 15,100	*5600 *12,050	3850 8,350	3850 8,250	2550 5,500	*2500 1850		*2150 *4,750	1800 3,950	7590 24'10"
0 mm 0'0"	kg lb			*7000 *16,150	6550 14,100	5750 12,300	3650 7,850	3750 8,000	2450 5,300			*2400 *5,250	1850 4,000	7430 24'4"
-1500 mm -5'0"	kg lb	*4300 *9,650	*4300 *9,650	*8500 *18,350	6450 13,800	5600 12,050	3550 7,600	3650 7,850	2400 5,150			*2850 *6,250	2000 4,350	6940 22'8"
-3000 mm -10'0"	kg lb	*7450 *16,700	*7450 *16,700	*6650 *14,350	6500 13,950	*4700 *10,000	3550 7,650	*3000	2450			*2950 *6,400	2400 5,300	6050 19'8"
-4500 mm -15'0"	kg lb			*3450 *7,050	*3450 *7,050							*2050 *4,250	*2050 *4,250	4490 14'4"

Reach Boom Lift Capacities – Counterweight: 3.83 mt (8,440 lb) – without Bucket – Blade Up

2700 mm (8'10") Blade

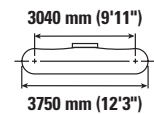
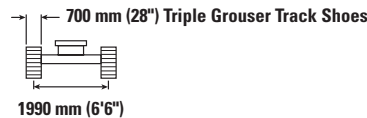
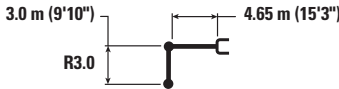

		1500 mm (5'0")		3000 mm (10'0")		4500 mm (15'0")		6000 mm (20'0")		7500 mm (25'0")		mm ft/in		
7500 mm 25'0"	kg lb					*2700	*2700					*2600 *5,850	*2600 *5,850	4540 14'3"
6000 mm 20'0"	kg lb					*3450 *7,550	*3450 *7,550	*2400	*2400			*2200 *4,850	*2200 *4,850	6070 19'8"
4500 mm 15'0"	kg lb					*3650 *7,950	*3650 *7,950	*3450 *7,400	2800 6,000			*2050 *4,500	*2050 *4,500	6960 22'8"
3000 mm 10'0"	kg lb			*5850 *12,100	*5850 *12,100	*4800 *10,350	4200 9,050	*3950 *8,550	2700 5,850			*2050 *4,500	1950 4,250	7440 24'4"
1500 mm 5'0"	kg lb			*8750 *18,800	7100 15,300	*5600 *12,050	3900 8,450	3900 8,350	2600 5,600	*2500 1850		*2150 *4,750	1850 4,000	7590 24'10"
0 mm 0'0"	kg lb			*7000 *16,150	6650 14,300	5800 12,500	3700 7,950	3800 8,100	2500 5,350			*2400 *5,250	1850 4,050	7430 24'4"
-1500 mm -5'0"	kg lb	*4300 *9,650	*4300 *9,650	*8500 *18,350	6550 14,000	5700 12,200	3600 7,750	3700 7,950	2450 5,250			*2850 *6,250	2000 4,400	6940 22'8"
-3000 mm -10'0"	kg lb	*7450 *16,700	*7450 *16,700	*6650 *14,350	6600 14,150	*4700 *10,000	3600 7,750	*3000	2450			*2950 *6,400	2450 5,400	6050 19'8"
-4500 mm -15'0"	kg lb			*3450 *7,050	*3450 *7,050							*2050 *4,250	*2050 *4,250	4490 14'4"



ISO 10567:2007



* Indicates that the load is limited by hydraulic lifting capacity rather than tipping load. The above loads are in compliance with hydraulic excavator lift capacity standard ISO 10567:2007. They do not exceed 87% of hydraulic lifting capacity or 75% of tipping load. Weight of all lifting accessories must be deducted from the above lifting capacities. Lifting capacities are based on the machine standing on a firm, uniform supporting surface. The use of a work tool attachment point to handle/lift objects, could affect the machine lift performance.

Lift capacity stays with ±5% for all available track shoes.

Always refer to the appropriate Operation and Maintenance Manual for specific product information.

315 GC Hydraulic Excavator Specifications

Bucket Specifications and Compatibility

	Linkage	Width		Capacity		Weight		Fill %	Reach Boom		
		mm	in	m ³	yd ³	kg	lb		R2.8 (9'2")	R2.8 (9'2") Thumb Ready Stick	R3.0 (9'10")
									●	⊙	⊖
Pin-On (No Quick Coupler)											
General Duty	312	450	18	0.20	0.27	268	591	100	●	●	●
	312	600	24	0.31	0.40	320	706	100	●	●	●
	312	750	30	0.41	0.54	369	814	100	●	●	●
	312	1050	42	0.65	0.84	468	1,031	100	●	⊙	⊙
General Duty – Wide Tip	312	450	18	0.27	0.36	317	700	100	●	●	●
	312	600	24	0.41	0.53	372	821	100	●	●	●
	312	750	30	0.55	0.72	425	936	100	●	●	●
	312	900	36	0.71	0.92	478	1,053	100	⊙	⊙	⊙
Severe Duty	312	1050	42	0.86	1.13	530	1,168	100	⊖	⊖	○
	312	600	24	0.31	0.40	372	820	90	●	●	●
	312	750	30	0.41	0.54	433	954	90	●	●	●
Clean Up	312	900	36	0.53	0.69	495	1,090	90	●	●	●
	312	1500	60	1.02	1.33	630	1,389	100	◇	◇	◇
Ditch Cleaning	312	1200	48	0.57	0.74	388	855	100	●	●	●
	312	1500	60	0.74	0.97	455	1,003	100	⊙	⊙	⊖
Ditch Cleaning Tilt	312	1200	48	0.48	0.63	563	1,240	100	●	●	●
	312	1500	60	0.57	0.75	646	1,424	100	●	⊙	⊙
								kg	1790	1760	1720
								lb	3,954	3,880	3,787
With Cat Pin Grabber Coupler											
General Duty	312	450	18	0.20	0.27	268	591	100	●	●	●
	312	600	24	0.31	0.40	320	706	100	●	●	●
	312	750	30	0.41	0.54	369	814	100	●	●	●
	312	1050	42	0.65	0.84	468	1,031	100	⊙	⊙	⊖
	312	1200	48	0.76	1.00	508	1,119	100	⊖	⊖	○
General Duty – Wide Tip	312	450	18	0.27	0.36	317	700	100	●	●	●
	312	600	24	0.41	0.53	372	821	100	●	●	●
	312	750	30	0.55	0.72	425	936	100	●	●	⊙
	312	900	36	0.71	0.92	478	1,053	100	⊖	⊖	⊖
	312	1050	42	0.86	1.13	530	1,168	100	○	○	○
Severe Duty	312	1200	48	1.02	1.33	582	1,283	100	◇	◇	◇
	312	600	24	0.31	0.40	372	820	90	●	●	●
	312	750	30	0.41	0.54	433	954	90	●	●	●
Clean Up	312	900	36	0.53	0.69	495	1,090	90	●	●	●
	312	1500	60	1.02	1.33	630	1,389	100	◇	◇	◇
Ditch Cleaning	312	1200	48	0.57	0.74	388	855	100	●	●	⊙
	312	1500	60	0.74	0.97	455	1,003	100	⊖	⊖	⊖
Ditch Cleaning Tilt	312	1200	48	0.48	0.63	563	1,240	100	●	●	⊙
	312	1500	60	0.57	0.75	646	1,424	100	⊖	⊖	⊖
								kg	1594	1560	1518
								lb	3,514	3,440	3,347

The above loads are in compliance with hydraulic excavator standard EN474-5:2006 + A3:2013, they do not exceed 87% of hydraulic lifting capacity or 75% of tipping capacity with front linkage fully extended at ground line with bucket curled. Capacity based on ISO 7451:2007.

Maximum Material Density:

- 2100 kg/m³ (3,500 lb/yd³)
- ⊙ 1800 kg/m³ (3,000 lb/yd³)
- ⊖ 1500 kg/m³ (2,500 lb/yd³)
- 1200 kg/m³ (2,000 lb/yd³)
- ◇ 900 kg/m³ (1,500 lb/yd³)

Caterpillar recommends using appropriate work tools to maximize the value customers receive from our products. Use of work tools, including buckets, which are outside of Caterpillar's recommendations or specifications for weight, dimensions, flows, pressures, etc. may result in less-than-optimal performance, including but not limited to reductions in production, stability, reliability, and component durability. Improper use of a work tool resulting in sweeping, prying, twisting and/or catching of heavy loads will reduce the life of the boom and stick.

315 GC Hydraulic Excavator Specifications

Attachments Offering Guide

Not all Attachments are available in all regions. Consult your Cat dealer for configurations available in your region.

Match

* Working range front only

PIN-ON ATTACHMENTS

Boom Type		Reach Boom		
		R2.8 (9'2")		
Stick Length		R2.8 (9'2")	Thumb Ready Stick	R3.0 (9'10")
Hydraulic Hammers	H110 GC	✓	✓	✓
	H110 GC S	✓	✓	✓
	H110 S	✓	✓	✓
	H115 GC	✓	✓	✓
	H115 GC S	✓	✓	✓
	H115 S	✓	✓	✓
Compactors (Vibratory Plate)	CVP75	✓	✓	✓

CAT PIN GRABBER COUPLER ATTACHMENTS

Boom Type		Reach Boom		
		R2.8 (9'2")		
Stick Length		R2.8 (9'2")	Thumb Ready Stick	R3.0 (9'10")
Hydraulic Hammers	H110 GC	✓	✓	✓
	H110 GC S	✓	✓	✓
	H110 S	✓	✓	✓
	H115 GC	✓*	✓*	✓*
	H115 GC S	✓	✓	✓
	H115 S	✓	✓	✓
Compactors (Vibratory Plate)	CVP75	✓	✓	✓

S60 DEDICATED COUPLER ATTACHMENTS

Boom Type		Reach Boom		
		R2.8 (9'2")		
Stick Length		R2.8 (9'2")	Thumb Ready Stick	R3.0 (9'10")
Hydraulic Hammers	H110 GC	✓	✓	✓
	H110 GC S	✓	✓	✓
	H110 S	✓	✓	✓
	H115 GC	✓	✓	✓*
	H115 GC S	✓	✓	✓
	H115 S	✓	✓	✓
Compactors (Vibratory Plate)	CVP75	✓	✓	✓

HCS60 COUPLER ATTACHMENTS

Boom Type		Reach Boom		
		R2.8 (9'2")		
Stick Length		R2.8 (9'2")	Thumb Ready Stick	R3.0 (9'10")
Hydraulic Hammers	H110 S	✓	✓	✓
	H115 S	✓	✓	✓
Compactors (Vibratory Plate)	CVP75	✓	✓	✓

HCS65 COUPLER ATTACHMENTS

Boom Type		Reach Boom		
		R2.8 (9'2")		
Stick Length		R2.8 (9'2")	Thumb Ready Stick	R3.0 (9'10")
Hydraulic Hammers	H110 S	✓	✓	✓
	H115 S	✓	✓	✓
Compactors (Vibratory Plate)	CVP75	✓	✓	✓

BOOM-MOUNT ATTACHMENTS

Boom Type		Reach Boom		
Mobile Scrap and Demolition Shears	S3025 Flat Top		✓	

315 GC Hydraulic Excavator Specifications

Thumb Specifications

Match

No Match

Bucket Type	Tooth Quantity	Width		Pro Plus		Pro		Stiff Link		Utility	
		mm	in	Pin-on	Cat Pin Grabber	Pin-on	Cat Pin Grabber	Pin-on	Cat Pin Grabber	Pin-on	Cat Pin Grabber
General Duty	3	450	18					✓	✓	✓	✓
	4	600	24		✓		✓	✓	✓	✓	✓
	5	750	30	✓	✓	✓	✓	✓	✓	✓	✓
	6	900	36	✓	✓	✓	✓	✓	✓	✓	✓
	7	1050	42	✓	✓	✓	✓	✓	✓	✓	✓
	7	1200	48	✓	✓	✓	✓	✓	✓	✓	✓
General Duty – Wide Tip	4	450	18					✓	✓	✓	✓
	5	600	24					✓	✓	✓	✓
	7	900	36					✓	✓	✓	✓
	8	1074	42					✓	✓	✓	✓
	9	1226	48					✓	✓	✓	✓
Severe Duty	3	600	24		✓		✓	✓	✓	✓	✓
	4	750	30	✓	✓	✓	✓	✓	✓	✓	✓
	5	900	36	✓	✓	✓	✓	✓	✓	✓	✓
	5	1050	42	✓	✓	✓	✓	✓	✓	✓	✓

315 GC Standard and Optional Equipment

Standard and Optional Equipment

Standard and optional equipment may vary. Consult your Cat dealer for details.

	Standard	Optional		Standard	Optional
BOOMS, STICKS AND LINKAGES			CAT TECHNOLOGY		
4.65 m (15'3") Reach boom	✓		VisionLink®	✓*	
2.8 m (9'2") Reach stick		✓	VisionLink Productivity		✓
2.8 m (9'2") Thumb Ready stick		✓	Remote Flash	✓	
3.0 m (9'10") Reach stick		✓	ELECTRICAL SYSTEM		
Bucket linkage, with lifting eye	✓		Maintenance free battery	✓	
CAB			Centralized electrical disconnect switch	✓	
ROPS	✓		LED chassis light, left-hand boom lights, cab lights – 1,800 lumens	✓	
High-resolution 203 mm (8") LCD touchscreen monitor	✓		LED right-hand boom light – 1,800 lumens		✓
Auto bi-level air conditioner	✓		Programmable time-delay LED working lights	✓	
Jog dial and shortcut keys for monitor control	✓		ENGINE		
Keyless push-to-start engine control	✓		Cat® C3.6 single turbo diesel engine	✓	
Height-adjustable console	✓		Two selectable modes: Power, Smart	✓	
Tilt-up left-side console	✓		Automatic engine speed control	✓	
Mechanical-suspension seat	✓		Automatic engine shutdown	✓	
51 mm (2") seat belt	✓		52° C (125° F) high-ambient cooling capacity without derate	✓	
Bluetooth® integrated radio (with USB, auxiliary port or microphone)	✓		–25° C (–13° F) cold start capability	✓	
12V DC outlets	✓		Electric fuel priming pump	✓	
Document storage	✓		Variable speed fan	✓	
Cup and bottle holders	✓		Single fuel filtration system with water separator and indicator	✓	
Openable two-piece front window	✓		Sealed double element air filter with precleaner	✓	
Rear window emergency exit	✓		*Connect subscription only. Additional subscriptions are available. Contact your Cat dealer for availability.		
Upper radial wiper with washer	✓		<i>(continued on next page)</i>		
Openable steel hatch	✓				
LED dome light	✓				
Roller front sunscreen	✓				
Roller rear sunscreen		✓			
Washable floor mat	✓				
Beacon ready	✓				

315 GC Standard and Optional Equipment

Standard and Optional Equipment *(continued)*

Standard and optional equipment may vary. Consult your Cat dealer for details.

	Standard	Optional		Standard	Optional
HYDRAULIC SYSTEM			SERVICE AND MAINTENANCE		
Electronic main control valve	✓		Integrated vehicle health management system	✓	
Single type electronic pump	✓		Grouped engine oil and fuel filters	✓	
Boom and stick regeneration circuits	✓		Lockable disconnect switch	✓	
Automatic two-speed travel	✓		Ground level engine oil dipstick	✓	
Boom and stick drift reduction valve	✓		Scheduled Oil Sampling (S·O·S SM) ports	✓	
Electric boom snubber	✓		UNDERCARRIAGE AND STRUCTURES		
Swing drive, without fine swing control function	✓		500 mm (20") triple grouser track shoes		✓
Medium-pressure line		✓	500 mm (20") triple grouser track shoes with rubber pad		✓
High-pressure line		✓	500 mm (20") rubber shoes		✓
Quick coupler line		✓	600 mm (24") triple grouser track shoes		✓
SAFETY AND SECURITY			600 mm (24") rubber shoes		✓
Rear and right-side-view cameras	✓		700 mm (28") triple grouser track shoes		✓
Ground level engine shutoff switch	✓		2500 mm (8'2") blade		✓
Service platform with anti-skid plate and countersunk bolts	✓		2600 mm (8'6") blade		✓
Signaling/warning horn	✓		2700 mm (8'10") blade		✓
Swing alarm		✓	Grease lubricated track link	✓	
Inspection lighting		✓	Center track guiding guards	✓	
Auto Hammer Stop	✓		Bottom guards	✓	
			Swivel guard	✓	
			Travel motor guards	✓	
			3.83 mt (8,440 lb) counterweight	✓	
			Tie-down points on base frame	✓	

Dealer Installed Kits and Attachments

Attachments may vary. Consult your Cat dealer for details.

CAB

- Radial lower wiper
- Left-hand and right-hand electrical pedal (two-way) for tool control
- Dual exit rear window kit
- Rain protector plus cab light cover
- Polycarbonate roof hatch
- Front windshield laminated glass (P5A glass, EU demolition regulation)
- Key fob (for use with Bluetooth receiver)

SAFETY AND SECURITY

- Bluetooth receiver
- 76 mm (3") retractable seat belt

GUARDS

- OPG (not compatible with cab light cover, rain protector)
- Mesh guard full front (not compatible with cab light cover, rain protector)
- Mesh guard lower half front
- Full protecting vandalism guard

SERVICE AND MAINTENANCE

- Grease gun holder

The following information applies to the machine at the time of final manufacture as configured for sale in the regions covered in this document. The content of this declaration is valid as of the date issued; however, content related to machine features and specifications are subject to change without notice. For additional information, please see the machine's Operation and Maintenance Manual.

For more information on sustainability in action and our progress, please visit <https://www.caterpillar.com/en/company/sustainability>.

Engine

- The Cat® C3.6 engine meets U.S. EPA Tier 4 Final, EU Stage V, and Japan 2014 emission standards.
- Cat diesel engines are required to use ULSD (ultra-low sulfur diesel fuel with 15 ppm of sulfur or less) or ULSD blended with the following lower-carbon intensity fuels** up to:
 - ✓ 20% biodiesel FAME (fatty acid methyl ester)*
 - ✓ 100% renewable diesel, HVO (hydrotreated vegetable oil) and GTL (gas-to-liquid) fuels

Refer to guidelines for successful application. Please consult your Cat dealer or “Caterpillar Machine Fluids Recommendations” (SEBU6250) for details.

**Engines with no aftertreatment devices can use higher blends, up to 100% biodiesel (for use of blends higher than 20% biodiesel, consult your Cat dealer).*

***Tailpipe greenhouse gas emissions from lower-carbon intensity fuels are essentially the same as traditional fuels.*

Air Conditioning System

- The air conditioning system on this machine contains the fluorinated greenhouse gas refrigerant R134a (Global Warming Potential = 1430). The system contains 0.8 kg (1.8 lb) of refrigerant which has a CO₂ equivalent of 1.144 metric tonnes (1.261 tons).

Paint

- Based on best available knowledge, the maximum allowable concentration, measured in parts per million (PPM), of the following heavy metals in paint are:
 - Barium < 0.01%
 - Cadmium < 0.01%
 - Chromium < 0.01%
 - Lead < 0.01%

Sound Performance

ISO 6395:2008 (external)	101 dB(A)
ISO 6396:2008 (inside cab)	71 dB(A)

- Hearing protection may be needed when operating with an open operator station and cab (when not properly maintained or doors/windows open) for extended periods or in a noisy environment.

Oils and Fluids

- Caterpillar factory fills with ethylene glycol coolants. Cat Diesel Engine Antifreeze/Coolant (DEAC) and Cat Extended Life Coolant (ELC) can be recycled. Consult your Cat dealer for more information.
- Cat Bio HYDO™ Advanced is an EU Ecolabel approved biodegradable hydraulic oil.
- Additional fluids are likely to be present, please consult the Operations and Maintenance Manual or the Application and Installation guide for complete fluid recommendations and maintenance intervals.

Features and Technology

- The following features and technology may contribute to fuel savings and/or carbon reduction. Features may vary. Consult your Cat dealer for details.
 - Advanced hydraulic systems balance power and efficiency
 - Smart mode matches machine power to digging requirements automatically
 - Eco mode minimizes fuel consumption for light applications
 - One-touch low idle with automatic engine speed control
 - Cat Grade with 2D improves operator efficiency by up to 45%
 - Cut maintenance costs up to 25% with extended and synchronized intervals
 - Remote Flash and Remote Troubleshoot

Recycling

- The materials included in machines are categorized as below with approximate weight percentage. Because of variations of product configurations, the following values in the table may vary.

Material Type	Weight Percentage
Steel	83.27%
Iron	5.01%
Nonferrous Metal	1.86%
Mixed Metal	0.37%
Mixed-Metal and Nonmetal	2.40%
Plastic	0.08%
Rubber	1.67%
Mixed Nonmetallic	1.45%
Fluid	2.40%
Other	1.49%
Uncategorized	0.00%
Total	100%

- A machine with higher recyclability rate will ensure more efficient usage of valuable natural resources and enhance End-of-Life value of the product. According to ISO 16714:2008 (Earthmoving machinery – Recyclability and recoverability – Terminology and calculation method), recyclability rate is defined as percentage by mass (mass fraction in percent) of the new machine potentially able to be recycled, reused or both.

All parts in the bill of material are first evaluated by component type based on a list of components defined by the ISO 16714:2008 and Japan CEMA (Construction Equipment Manufacturers Association) standards. Remaining parts are further evaluated for recyclability based on material type.

Because of variations of product configurations, the following value in the table may vary.

Recyclability – 95%

For more complete information on Cat products, dealer services, and industry solutions, visit us on the web at www.cat.com

© 2023 Caterpillar
All rights reserved

Materials and specifications are subject to change without notice. Featured machines in photos may include additional equipment. See your Cat dealer for available options.

CAT, CATERPILLAR, LET'S DO THE WORK, their respective logos, "Caterpillar Corporate Yellow," the "Power Edge" and Cat "Modern Hex" trade dress as well as corporate and product identity used herein, are trademarks of Caterpillar and may not be used without permission. VisionLink is a trademark of Caterpillar Inc., registered in the United States and in other countries.

AEXQ3022-03 (12-2023)
Replaces AEXQ3022-02
Build Number: 07E
(N Am)

