

## Introduction

This document provides instructions for installing an accessory on a Cat® Utility Vehicle (CUV). Do not perform any procedure in this document until you have read and understood the information contained in this document and the Operation and Maintenance Manual.

## Safety Section

### WARNING

Do not operate or work on this product unless you have read and understood the instruction and warnings in the relevant Operation and Maintenance Manuals and relevant service literature. Failure to follow the instructions or heed the warnings could result in injury or death. Proper care is your responsibility.

### WARNING

Failure to follow all safety guidelines prescribed in this document and by governing authorities and regulatory agencies may result in severe injury or death of personnel or machine damage.

### WARNING

When removing a major component or attachment, ensure that it is properly blocked or secured before removing mounting hardware. An assembly that is disconnected without proper blocking may shift or fall, resulting in serious injury or death of personnel or machine damage.

### WARNING

Personal injury or death can result from improper maintenance procedures. To avoid injury or death, follow the procedures exactly as stated below.

### WARNING

Personal injury can result from improper handling of chemicals. Make sure you use all the necessary protective equipment required to do the job. Make sure that you read and understand all directions and hazards described on the labels and material safety data sheet of any chemical that is used. Observe all safety precautions recommended by the chemical manufacturer for handling, storage, and disposal of chemicals.

### WARNING

Before servicing/performing maintenance on the machine, electrical power must be physically disconnected; battery cables must be disconnected from the battery. All applicable lock out and tag out procedures must be followed.

### WARNING

Observe the safe working load limits of all lifting and blocking devices and keep a safe distance from suspended/blocked loads. Personnel may be seriously injured or killed by falling loads.

### WARNING

Do not operate the machine if any guards or covers are missing or inadequately secured. Personnel could be seriously injured or machine damage may occur.

# Caterpillar® Installation Instructions Front Headrest Kit (p/n 576-9839)



■ **NOTE:** Read these Installation Instructions thoroughly before beginning the installation process. Retain these Installation Instructions for future reference.

## Kit includes:

QTY	DESCRIPTION
1	Headrest Frame Tube
2	Headrest Bracket
1	Headrest Cover Plate
4	Cap Screw (M6 x 12 mm)
2	Headrest Pad
8	Rivet
2	Shoulder Bolt

## Tools Required:

- Rivet Gun
- T30 Torx Bit
- 16 mm Socket/Wrench
- 18 mm Socket/Wrench
- Torque Wrench

1. Remove the cap screws and nuts securing the seat belts to the rear ROPS. See Fig. 1.

Fig. 1

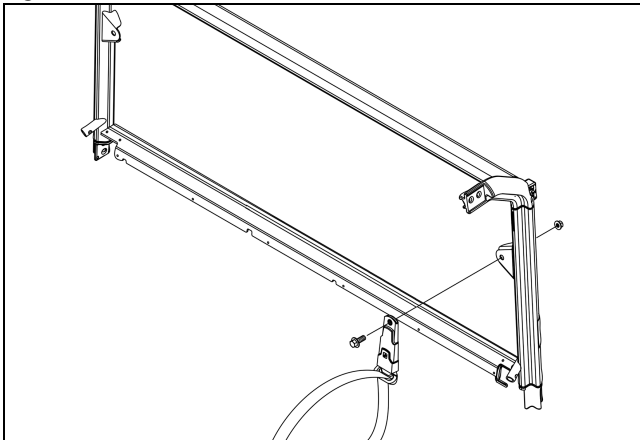

VOR-642

2. Secure the two Headrest Brackets to the bottom side of the frame tube using four Cap Screws M6 x 12 mm). Tighten to 54 in.-lb. See Fig. 2.
3. Secure Headrest Pads to the frame tube and the brackets using eight Rivets. See Fig. 2.

Fig. 2

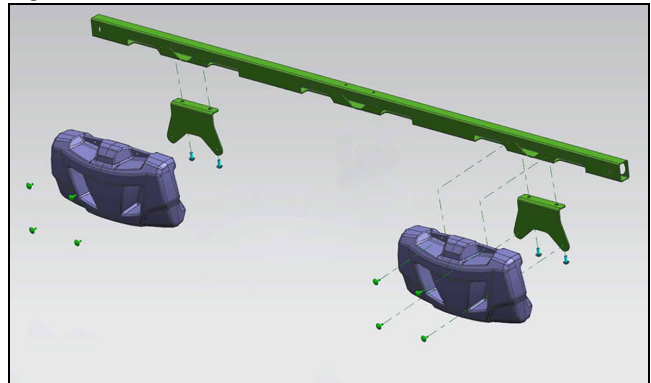

VOR-643

4. Position Headrest Frame Tube on the back side of the ROPS tube aligning with the existing seat belt bracket holes; then secure the seat belts and the headrest frame tube to the ROPS using two new Shoulder Bolts and the existing nuts. Tighten to 35 ft.-lb. See Fig. 3.

Fig. 3

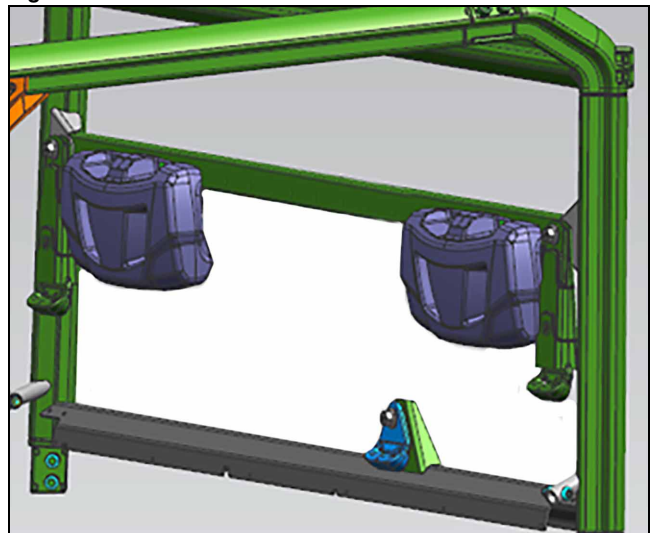

VOR-644