



Cat[®] D3

DOZER

FEATURES:

The new Cat[®] D3 delivers superior performance and the broadest choice of technology features to help you get the most from your dozer. Nimble and responsive, it has power for dozing and finesse for grading. Fully hydrostatic transmission gives you seamless acceleration, so you can get the job done quickly. The load sensing system automatically optimizes ground speed based on load, for the greatest productivity and fuel efficiency.

IMPROVED VISIBILITY

- New sloped hood provides better visibility to the work in front of the blade as well as the overall job site. Better visibility can equal less operator fatigue and more confidence in your work.

ENHANCED TECHNOLOGY

Cat small dozers include a suite of Operator Assist features that work seamlessly to save time, effort, fuel, machine wear and overall costs. Cat Grade with Assist is an optional technology available for small dozers.

- **Steer Assist** automates track steering with light or heavy loads and automates blade tilt steering to help push heavy loads with less effort. This feature helps reduce operator inputs by up to 75% and enhances operator efficiency and productivity. Steer Assist is standard with Assist with Attachment Ready Option (ARO). Steer Assist 3D is standard with Grade 3D with Assist.
- **Stable Blade Lift and Tilt** automatically works behind the scenes to allow operators to create smooth surfaces with less effort using accelerometers on the blade and chassis with an advanced algorithm to make minor blade raise and lower movements. This feature is standard with Assist with ARO and Grade 3D with Assist.
- **Blade Load Monitor** provides real-time feedback of current load vs. target load to fully utilize machine capacity benefiting operators of all skills levels. Automatically compensates for ground conditions. This feature is not available indoors or in areas where a GPS signal is not available. Blade Load Monitor is standard with Assist with ARO and Grade 3D with Assist.
- **Traction Control** prevents excessive track slip to improve machine efficiency and reduce burden on the operator. Feature offers two modes: Normal Mode helps when pushing heavy blade loads by limiting non-productive track slip, recommended for most applications. And Low Slip Mode limits track slip for applications sensitive to slip such as spreading material on top of a liner, select this mode when needed. Traction Control is standard with Assist with ARO and Grade 3D with Assist.

- **AutoCarry™** raises and lowers the blade to maximize pushing capability and prevent excessive track slip when pushing heavy loads. Feature is designed to work in unison with other Operator Assist Features. Not available indoors or in areas where a GPS signal is not available. AutoCarry is standard with Assist with ARO and Grade 3D with Assist.
- **Scalable Grade 2D and 3D with Assist** is an optional feature that makes your job up to 39% faster with up to 82% fewer operator inputs and less rework by maintaining blade angles for better surface quality – even with less experienced operators.

UP TO 10% IMPROVED FUEL ECONOMY

- The D3 features the lowest fuel consumption in this size class with the same great performance you've come to expect. Up to 20% improvement and no performance sacrifice when ECO mode is active.

COMFORTABLE WORK SPACE

- The spacious and comfortable cab features an optional heated and ventilated seat, along with heated joystick controls to make the operator comfortable no matter what the conditions are outside. The seat height and armrests can be easily adjusted to the operator's preference.

BIGGER, BETTER DISPLAY WITH CAMERA

- This new and improved optional 10 in (254 mm) touchscreen, color display is easy to use, with a great view of machine settings, rearview camera and Slope Indicate/Slope Assist screens. The large reversing camera gives the operator better visibility to the job site.

DURABLE UNDERCARRIAGE

- The D3 is available with either a Heavy Duty (HD) or Abrasion undercarriage to best suit your application. The undercarriage has a longer life resulting in less down time. A one piece mainframe/track roller frame design and the large, double reduction planetary final drive allow the machine to push heavy loads.



Specifications

Engine

Engine Model	Cat® C3.6	
Net Power @ 2,200 rpm		
SAE J1349	77.6 kW	104 hp
ISO 9249, 80/1269/EEC	77.6 kW	104 hp
Power Train	Hydrostatic	
Displacement	3.6 L	220 in ³

- Net power is tested per ISO 9249:2007 and SAE J1349:2011 and as advertised is the power available at the flywheel when the engine is equipped with fan, air intake system, exhaust system and alternator.

Weights

Operating Weight	9362 kg	20,640 lb
Operating Weight – LGP	9693 kg	21,369 lb
Operating Weight – LGP, 762 mm/30 in	9893 kg	21,810 lb

- Specifications shown are for machine equipped with dozer blade, Enclosed Roll Over Protective Structure (EROPS) cab, back-up alarm, operator, coolant, lubricants and full fuel tank.
- For machine with ripper, add 554 kg (1,222 lb).

Cab

Rollover Protective Structure (ROPS)	ISO 3471:2008
Falling Object Protective Structure (FOPS)	ISO 3449:2005 Level II

Transmission

Drive Pumps	1	
Track Motors	2	
Relief Valve Settings	48 500 kPa	7,033 psi
Maximum Travel Speed – Forward	9 km/h	5.6 mph
Maximum Travel Speed – Reverse	10 km/h	6.2 mph

Undercarriage

Number of Rollers (each side)	7	
Number of Shoes (each side) – Heavy Duty (HD) Undercarriage	40	
Number of Shoes (each side) – Abrasion Undercarriage	36	
Shoe Width	510 mm	20 in
Shoe Width – LGP	660 mm	26 in
Shoe Width – LGP, 762 mm (30 in)	762 mm	30 in
Length of Track on Ground	2310 mm	91 in
Length of Track on Ground – LGP	2310 mm	91 in
Length of Track on Ground – LGP, 762 mm (30 in)	2310 mm	91 in
Track Gauge	1600 mm	63 in
Track Gauge – LGP	1750 mm	69 in
Track Gauge – LGP, 762 mm (30 in)	1860 mm	73 in
Ground Pressure	38.9 kPa	5.7 psi
Ground Pressure – LGP	31.2 kPa	4.5 psi
Ground Pressure – LGP, 762 mm (30 in)	27.2 kPa	3.9 psi

Service Refill Capacities

Fuel Tank	195 L	51.5 gal
Crankcase and Filter	10.5 L	2.8 gal
Final Drives, (each side)	10 L	2.6 gal
Final Drives, LGP (each side)	10 L	2.6 gal
Cooling System	19 L	5.0 gal
Transmission/Hydraulic Tank	90 L	23.8 gal

Specifications *(continued)*

Hydraulic Controls

Pump Output	65 L/min	17.2 gal/min
Relief Valve Settings	20 600 kPa	2,988 psi

Ripper

Type	Parallelogram	
Number of Shanks	3	
Maximum Digging Depth	337.5 mm	13.3 in
Maximum Reach at Ground Line	766 mm	30.2 in
Maximum Ground Clearance Under Tip	448 mm	17.6 in
Overall Width	1710 mm	67.3 in
Height	165 mm	6.5 in
Weight	554 kg	1,222 lb

High Performance Winch

Weight	610 kg	1,345 lb
Winch Drive	Hydrostatic	
Control	Hydraulic	
Speed	Variable	
Winch Length	705 mm	27.76 in
Overall Width	741 mm	29.2 in
Drum Diameter	254 mm	10 in
Drum Width	274 mm	10.8 in
Throat Clearance	171.5 mm	6.75 in
Rope Diameter – recommended	16 mm	0.63 in
Rope Diameter – optional	19 mm	0.75 in
Drum Capacity – recommended cable	113 m	371 ft
Drum Capacity – optional cable	78 m	256 ft
Maximum Line Pull – bare drum	18 144 kg	40,000 lb
Maximum Line Pull – full drum	11 340 kg	25,000 lb
Maximum Line Speed – bare drum	40 m/min	131 ft/min
Maximum Line Speed – full drum	63 m/min	207 ft/min

Retrieval Winch

Weight	794 kg	1,747 lb
Winch Drive	Hydraulic	
Control	Hydraulic	
Speed	Variable	
Winch Length	905 mm	35.63 in
Overall Width	709 mm	27.91 in
Drum Diameter	203.2 mm	8 in
Drum Width	245 mm	9.65 in
Throat Clearance	141.4 mm	5.6 in
Rope Diameter – recommended	16 mm	5/8 in
Rope Diameter – optional	19 mm	3/4 in
Drum Capacity – recommended cable	84 m	277 ft
Drum Capacity – optional cable	59 m	195 ft
Maximum Line Pull – bare drum	14 583 kg	32,150 lb
Maximum Line Pull – full drum	9231 kg	20,350 lb
Maximum Line Speed – bare drum	15 m/min	50 ft/min
Maximum Line Speed – full drum	24 m/min	79 ft/min

D3 Dozer

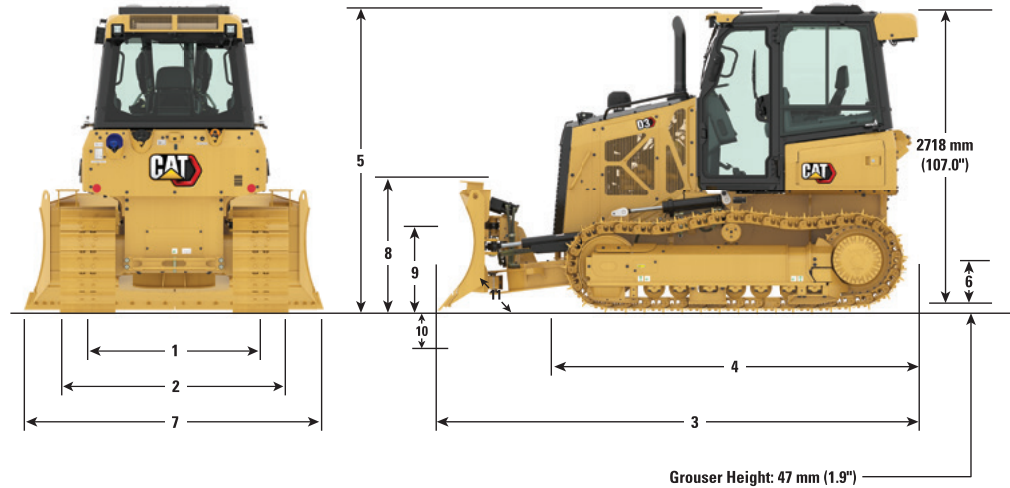

Dimensions*

	Standard		LGP		LGP, 762 mm (30 in)	
1 Track Gauge	1600 mm	63 in	1750 mm	67.9 in	1860 mm	73 in
2 Width of Dozer (standard shoes, no blade)	2110 mm	83 in	2410 mm	94.9 in	2630 mm	103.5 in
3 Overall Length (with blade)	4337 mm	170.7 in	4309 mm	169.6 in	4309 mm	169.6 in
4 Length of Basic Dozer (without blade)	3270 mm	128.7 in	3270 mm	128.7 in	3270 mm	128.7 in
5 Dozer Height	2769 mm	109 in	2769 mm	109 in	2769 mm	109 in
6 Ground Clearance	332 mm	13 in	332 mm	13 in	332 mm	13 in
With Ripper Attachment (add to Length of Basic Dozer)	1177 mm	46.3 in	1177 mm	46.3 in	1177 mm	46.3 in
BLADE	Standard		LGP			
7 Blade Width	2782 mm	109.5 in	3220 mm	126.7 in		
8 Blade Height	1073 mm	42.2 in	1010 mm	39.8 in		
9 Blade Lift Height	767 mm	30.2 in	767 mm	30.2 in		
10 Digging Depth	605 mm	23.8 in	590 mm	23.2 in		
11 Blade Cutting Edge Angle, Adjustable	52° to 58°		52° to 58°			
Maximum Tilt	402 mm	15.8 in	448 mm	17.7 in		
Maximum Angle (either side)	25°		25°			
Blade Width at Maximum Angle	2636 mm	103.8 in	2940 mm	115.8 in		
Blade Capacity (SAE)	2.19 m ³	2.86 yd ³	2.34 m ³	3.06 yd ³		

*Abrasion Undercarriage

Standard and Optional Equipment

Standard and optional equipment may vary. Consult your Cat dealer for details.

	Standard	Optional		Standard	Optional
POWER TRAIN			HYDRAULIC		
Air cleaner with precleaner, automatic dust ejection and underhood intake	✓		Hydraulic pump and oil	✓	
Air cleaner with external precleaner		✓	Four valve for use with ripper		✓
Aluminum bar plate cooling system (radiator, power train)	✓		Four valve for use with winch		✓
Automatic traction control	✓		Single lever, three function control	✓	
Cat C3.6 diesel engine	✓		Three valve hydraulics	✓	
Drive, auxiliary	✓		CAT TECHNOLOGY		
Dual path, closed loop, hydrostatic transmission	✓		Slope Indicate	✓	
Electric fuel pump	✓		Stable Blade – Basic Lift	✓	
Fuel/water separator	✓		Assist with Attachment Ready Option (ARO) includes:		✓
Installation, winch		✓	– Slope Indicate		
Turbocharged aftercooled	✓		– Blade Load Monitor		
ELECTRICAL			– Stable Blade Lift and Tilt		
Alarm, backup	✓		– Slope Assist		
Alternator, 150 amp, heavy duty	✓		– Traction Control		
Batteries, heavy duty, maintenance free, 1,000 CCA	✓		– Steer Assist		
Diagnostic connector	✓		– AutoCarry		
Four integrated front halogen lights, two rear halogen	✓		Grade 3D with Assist includes:		✓
Four integrated front LED lights, two rear LED		✓	– Same Assist with ARO features above		
Horn, electric	✓		– Steer Assist 3D		
Starter, electric, 12 V, heavy duty	✓		– Grade 3D		
UNDERCARRIAGE			Third party 3D grade system compatible	✓	
Heavy Duty (HD) Undercarriage (40 section)	✓		Cat Product Link™ PLE643/PLE743 Cellular	✓	
Abrasion Undercarriage (36 section)		✓	Cat Product Link PLE683/PLE783 Cellular/Satellite		✓
Track Pairs			Full-color 254 mm (10 in) touchscreen grade display		✓
– Track, 510 mm (20 in)		✓			
– Track, 660 mm (26 in)		✓			
– Track, 762 mm (30 in)		✓			
Carrier rollers	✓				
Guards, front/rear guiding	✓				
Seven roller track frame	✓				
Track adjusters, hydraulic	✓				
Track rollers, lifetime lubricated	✓				

(continued on next page)

D3 Dozer

Standard and Optional Equipment *(continued)*

Standard and optional equipment may vary. Consult your Cat dealer for details.

	Standard	Optional		Standard	Optional
OPERATOR ENVIRONMENT			ATTACHMENTS		
Armrests, adjustable	✓		Rigid drawbar	✓	
Cab, with air conditioning		✓	Drawbar, towing		✓
Cab, polycarbonate windows and air conditioning		✓	Front pull device	✓	
Coat hook	✓		Machine security system		✓
Controls, seat mounted, fore/aft adjustment	✓		Mounting, winch		✓
Cup holders	✓		Ripper, parallelogram, includes three shanks and teeth		✓
Eco Mode	✓		Winch, hydraulic, high performance		✓
Electronic Monitoring system with gauge:			Winch, hydraulic, retrieval		✓
– Chassis slope indication	✓		OTHER		
– Engine coolant temperature	✓		Heater, engine, coolant 120 V/240 V		✓
– Fuel level	✓		Starting aid, ether		✓
– Hydraulic oil temperature	✓				
Electronic security system	✓				
Engine air cleaner service indicator	✓				
Engine RPM and gear display	✓				
Floor mat, rubber, heavy duty	✓				
Foot pads, dash	✓				
Hour meter, electronic	✓				
Independent forward/reverse speed settings	✓				
Mirror, rearview, inside	✓				
Power port, 12 volt	✓				
Radio, AM/FM Bluetooth®		✓			
ROPS/FOPS canopy	✓				
Seat, air suspended, cloth or vinyl	✓				
Seat, air suspension, choice of:					
– Vinyl, heated seat with heated controls		✓			
– Cloth, heated seat with heated controls		✓			
– Cloth, heated and ventilated seat with heated controls		✓			
Seatbelt, hi-vis retractable 76 mm (3")	✓				
Seatbelt buckling indicator/reminder	✓				
Single pedal combining decel and brake functions	✓				
Sound suppression		✓			
Speed recall	✓				
Storage compartment	✓				
Throttle switch, rotary	✓				
Travel speed limiter, electronic	✓				

The following information applies to the machine at the time of final manufacture as configured for sale in the regions covered in this document. The content of this declaration is valid as of the date issued; however, content related to machine features and specifications are subject to change without notice. For additional information, please see the machine's Operation and Maintenance Manual.

For more information on sustainability in action and our progress, please visit <https://www.caterpillar.com/en/company/sustainability>.

Engine

- The Cat® C3.6 engine meets Brazil MAR-1 and China Nonroad Stage III, equivalent to U.S. EPA Tier 3/EU Stage IIIA.
- Cat engines are compatible with diesel fuel blended with the following lower-carbon intensity fuels** up to:
 - ✓ 100% biodiesel FAME (fatty acid methyl ester)*
 - ✓ 100% renewable diesel, HVO (hydrotreated vegetable oil) and GTL (gas-to-liquid) fuels

Refer to guidelines for successful application. Please consult your Cat dealer or “Caterpillar Machine Fluids Recommendations” (SEBU6250) for details.

**For use of blends higher than 20% biodiesel, consult your Cat dealer.*

***Tailpipe greenhouse gas emissions from lower-carbon intensity fuels are essentially the same as traditional fuels.*

Air Conditioning System

- The air conditioning system on this machine contains the fluorinated greenhouse gas refrigerant R134a (Global Warming Potential = 1430). The system contains 1.8 kg (4.0 lb) of refrigerant, which has a CO₂ equivalent of 2.574 metric tonnes (2.873 tons).

Paint

- Based on best available knowledge, the maximum allowable concentration, measured in parts per million (PPM), of the following heavy metals in paint are:
 - Barium < 0.01%
 - Cadmium < 0.01%
 - Chromium < 0.01%
 - Lead < 0.01%

Sound Performance

With cooling fan speed at 70% of the maximum value:

Guaranteed Exterior Sound Power (2000/14/EC ISO 6395:2008) – 109 dB(A)

Dynamic Operator Sound Pressure Level (ISO 6396:2008) – 76 dB(A)

- Hearing protection may be needed when operating with an open operator station and cab (when not properly maintained or doors/windows open) for extended periods or in a noisy environment.

Oils and Fluids

- Caterpillar factory fills with ethylene glycol coolants. Cat Diesel Engine Antifreeze/Coolant (DEAC) and Cat Extended Life Coolant (ELC) can be recycled. Consult your Cat dealer for more information.
- Cat Bio HYDO™ Advanced is an EU Ecolabel approved biodegradable hydraulic oil.
- Additional fluids are likely to be present, please consult the Operations and Maintenance Manual or the Application and Installation guide for complete fluid recommendations and maintenance intervals.

Features and Technology

- The following features and technology may contribute to fuel savings and/or carbon reduction. Features may vary. Consult your Cat dealer for details.
 - Eco mode minimizes fuel consumption for light applications
 - Save fuel with efficiency features such as engine idle shutdown
 - Extended maintenance intervals reduce fluid and filter consumption
 - Cut maintenance costs with extended maintenance intervals
 - Boost productivity up to 50% with Cat technologies Slope Indicate, Stable Blade Lift and Tilt, Steer Assist, Blade Load Monitor, Traction Control, AutoCarry and Grade 3D with Assist (features vary based on technology package selected).
 - Remote Flash and Remote Troubleshoot

Recycling

- The materials included in machines are categorized as below with approximate weight percentage. Because of variations of product configurations, the following values in the table may vary.

Material Type	Weight Percentage
Steel	81.19%
Iron	8.48%
Nonferrous Metal	3.29%
Uncategorized	1.87%
Fluid	1.52%
Other	1.36%
Mixed Metal	0.87%
Plastic	0.64%
Mixed-Metal and Nonmetal	0.60%
Rubber	0.18%
Mixed Nonmetallic	0%
Total	100.00%

- A machine with higher recyclability rate will ensure more efficient usage of valuable natural resources and enhance End-of-Life value of the product. According to ISO 16714:2008 (Earth-moving machinery – Recyclability and recoverability – Terminology and calculation method), recyclability rate is defined as percentage by mass (mass fraction in percent) of the new machine potentially able to be recycled, reused or both.

All parts in the bill of material are first evaluated by component type based on a list of components defined by the ISO 16714:2008 and Japan CEMA (Construction Equipment Manufacturers Association) standards. Remaining parts are further evaluated for recyclability based on material type.

Because of variations of product configurations, the following values in the table may vary.

Recyclability – 98%

The data provided above was based on the product configuration as provided by the individual product group.

D3 Dozer



For more complete information on Cat products, dealer services, and industry solutions, visit us on the web at www.cat.com

© 2024 Caterpillar
All rights reserved

Materials and specifications are subject to change without notice. Featured machines in photos may include additional equipment. See your Cat dealer for available options.

CAT, CATERPILLAR, LET'S DO THE WORK, their respective logos, "Caterpillar Corporate Yellow," the "Power Edge" and Cat "Modern Hex" trade dress as well as corporate and product identity used herein, are trademarks of Caterpillar and may not be used without permission.

AEHQ8311-02 (08-2024)
Replaces AEHQ8311-01
Build Number: 12B
(AME, S Am except Chile,
Peru, APD except Japan)

