

D2

DOZER



Net Power (2,200 rpm)

SAE J1349, ISO 9249, 80/1269/EEC 68.8 kW (92 hp)

Operating Weight

D2 8338 kg (18,382 lb)

D2 LGP 8648 kg (19,066 lb)

Cat® C3.6 Engine meets U.S. EPA Tier 4 Final/Japan 2014 (Tier 4 Final)/Korea Stage V/EU Stage V emission standards.



CAT[®] D2

PERFORMANCE AND EFFICIENCY

The **Cat[®] D2** delivers superior performance and the broadest choice of standard and optional features and technology to help you get the most from your dozer. Nimble and responsive, it has power for dozing, finesse for grading and gets any job done quickly and efficiently.



D2 DOZERS

SET THE STANDARD



BUILT FOR MAXIMUM PRODUCTIVITY

- + Fully hydrostatic transmission provides seamless acceleration
- + Load-sensing system automatically optimizes ground speed based on load
- + Improved visibility and a comfortable workspace ensure maximum operator productivity
- + Enhanced technology features work to save time, effort, fuel, machine wear and overall operating costs

UP TO 10% IMPROVED FUEL ECONOMY

- + Lowers operating costs to the customer
- + Lowest fuel consumption in this size class
- + Still same great performance you've come to expect
- + Up to 20% improvement and no performance sacrifice with ECO mode active
- + Engine efficiency enhancements

EASY OPERATION

The hydrostatic transmission provides infinite speed control—just choose the speed and go. The load-sensing system automatically optimizes ground speed based on load for the greatest productivity and fuel efficiency.

OPERATOR STATION

THE COMFORT AND CONTROL FOR A PRODUCTIVE SHIFT



IMPROVED VISIBILITY

The angle of the hood enhances the peripheral vision for the operator. The sloped hood allows for better assessment of the work in front of the blade and jobsite awareness. Better visibility can equal less operator fatigue and more confidence in your work.

WORKSPACE

Regardless of operator stature, step into a spacious and comfortable cab that resets the industry standard. An optional heated and ventilated seat, along with heated joystick controls, make the operator comfortable—no matter what the conditions are outside. The seat height adjustment is now easier to access, and armrests can be quickly adjusted to operator's preference—no tools required!

BIGGER, BETTER DISPLAY WITH CAMERA

Optional 10-inch (254-mm) touchscreen, color display is easy to use, with a great view of machine settings, rearview camera and Slope Indicate/Slope Assist™ screens. The large reversing camera gives the operator better visibility to the jobsite, as well as less fatigue at the end of the day. Additionally, the Key Features button gives the operator an overview of machine features, along with some helpful operating tips.

ENHANCED TECHNOLOGY

MAKES OPERATION EASIER AND MORE EFFICIENT

Operator Assist Technology

STABLE BLADE LIFT AND TILT

Automatically works behind the scenes to allow operators to create smooth surfaces with less effort, using accelerometers on the blade and chassis with an advanced algorithm to make minor blade raise and lower movements.



BLADE LOAD MONITOR

Provides real-time feedback of current load vs. target load to fully utilize machine capacity, benefiting operators of all skills levels. Automatically compensates for ground conditions.

This feature is not available indoors or in areas where a GPS signal is not available.

LOW SLIP TRACTION CONTROL

Prevents excessive track slip to improve machine efficiency and reduce burden on the operator. Feature offers two modes: Normal Mode helps when pushing heavy blade loads by limiting non-productive track slip – recommended for most applications; and Low Slip Mode limits track slip for applications sensitive to slip, such as spreading material on top of a liner.

AUTOCARRY™

Raises and lowers the blade to maximize pushing capability and prevent excessive track slip when pushing heavy loads. Feature is designed to work in unison with other Operator Assist features. Not available indoors or in areas where a GPS signal is not available.

Cat Grade with Slope Assist and Cat Grade with 3D

Cat Grade with Slope Assist makes any dozer job faster and easier by maintaining blade angles so you get better surface quality—even with less experienced operators. No base station or laser needed and no additional hardware, software or equipment to buy. Finish jobs up to 39% faster with fewer passes, up to 82% fewer operator inputs and less rework.

Cat Grade with 3D saves time, improves accuracy and increases productivity up to 50% compared to traditional grading, using a GPS signal to automatically adjust blade movements—both lift and tilt.

Cat Command Remote Control



Cat Command is an optional feature that takes you off the machine and away from hazardous conditions, dust, noise vibration or operating on unstable surfaces. Remote control operation also eliminates risk of injury from climbing on or off the machine. Integrated with dozer systems, Cat Command enables smooth, precise control, with access to all machine functions and advanced features (if equipped) for maximum efficiency and productivity.

Cat Link Technology

Takes the guesswork out of managing your equipment

CAT LINK telematics technology helps take the complexity out of managing your jobsites, by gathering data generated by your equipment, materials and people and serving it up to you in customizable formats.

CAT PRODUCT LINK™

Product Link™ collects data automatically and accurately from your assets—any type and any brand. Information such as location, hours, fuel usage, productivity, idle time, maintenance alerts, diagnostic codes and machine health can be viewed online through web and mobile applications.



VISIONLINK®

Access information anytime, anywhere with VisionLink®—and use it to make informed decisions that boost productivity, lower costs, simplify maintenance and improve safety and security on your jobsite. With different subscription-level options, your Cat dealer can help you configure exactly what you need to connect your fleet and manage your business, without paying for extras you don't want. Subscriptions are available with cellular or satellite reporting or both.



REMOTE SERVICES

The Cat App helps you manage your assets—at any time—right from your smart device. See fleet location and hours, get critical required maintenance alerts and even request service from your local Cat dealer.

- + Remote Flash lets you receive software updates to one or more machines remotely. You just need a designated person close to the machine to initiate/confirm the update.
- + Remote Grade lets you wirelessly manage site plans via Trimble Connect Services.
- + Operator ID lets you track machine operation by individual operator using the main display and Product Link.

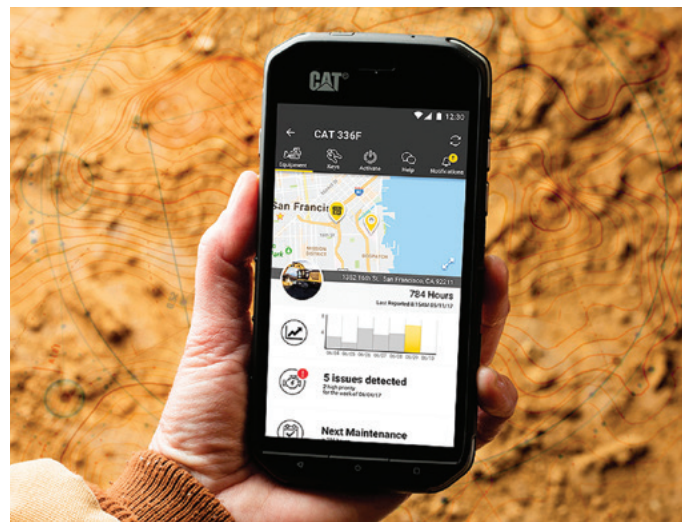

DURABILITY

UNMATCHED POWER WITHOUT COMPRISING MACHINE LONGEVITY

The small dozer final drive provides a large, double-reduction planetary gear set that allows the machine to push heavy loads. The undercarriage has a longer life, less downtime and is standard on all Cat Dozers. A one-piece mainframe/track roller frame design gives the machine the strength to carry pushing loads.

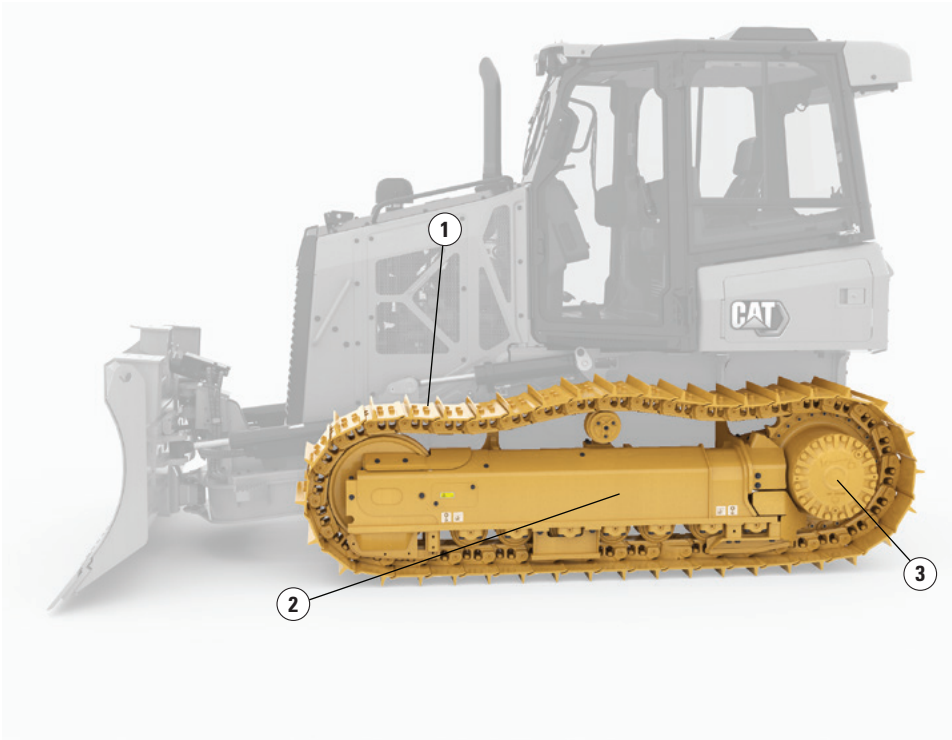

1. Two Track offerings: Sealed and Lubricated Track (SALT)/Abrasion
2. Track Roller Frame
3. Final Drive



FINAL DRIVE

- + Large planetary gear set
- + Heavy pushing load spread over multiple gears
- + Longer life and less downtime
- + Standard on all Cat dozers



SALT

- + Cost-effective
- + Eliminates internal pin and bushing wear
- + Long life
- + Universal applications



ABRASION

- + Longer undercarriage wear life
- + No link-assembly maintenance
- + No downtime for bushing turns
- + Less cost per hour by using full link life without a bushing turn
- + For high-abrasion applications



PUSH MORE. GRADE MORE.
POWER YOU CONTROL.

AUTOMATIC TRACTION CONTROL

Reduces track slippage with no operator interaction, resulting in less ground disturbance and fewer passes.

POWER TURN

Power to each track allows the dozer to carry heavy loads around turns.

COUNTER-ROTATION

Quick and easy spot turns, along with the ability to control dozer direction during heavy side loads.

SMOOTH CONTROLS

Controls with low operator effort provide predictable maneuverability.

VERSATILITY

SOLUTIONS TO SUIT YOUR UNIQUE APPLICATIONS AND WORK

We offer a full lineup of specialty dozer attachments and purpose-built machine configurations for unique applications.

Configure your machine to the application.

FORESTRY

- + Sweeps
- + Screens
- + Hinged radiator grill
- + External pre-cleaner

SPECIALTY APPLICATIONS

- + Fire Suppression Dozer—
firefighting and prevention
- + Shiphold—bulk material handling
operations

WINCH

- + Retrieval—great performance,
easy to install
- + High-performance—maximum
line speed and pull

RIPPER

- + Parallelogram linkage
- + 3-shank



Fire Suppression Dozer



Shiphold



Retrieval Winch

MAINTENANCE

MAKING UPKEEP MANAGEABLE

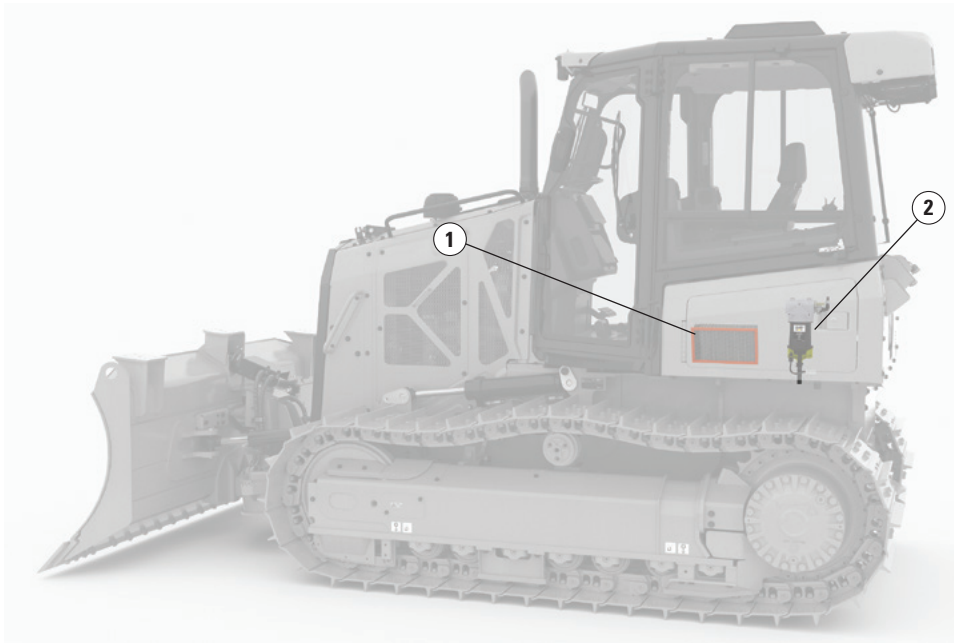

The Next Generation Small Dozers are easier than ever to service, with ground-level access to daily maintenance areas. Additionally, there are new options available to further simplify service, with the turbine-type pre-cleaner, reversing fan and hinged radiator grill.

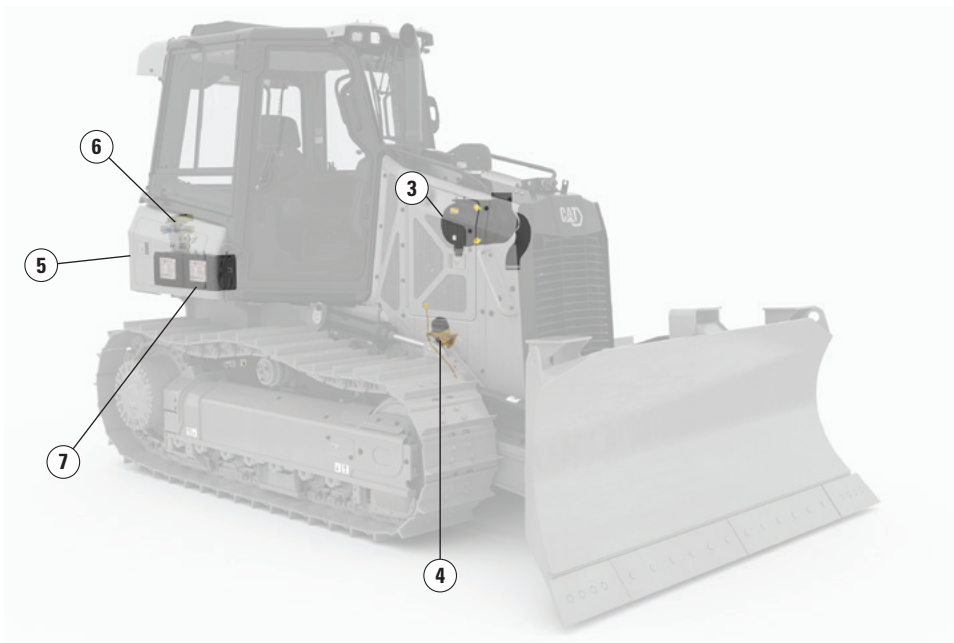

1. Cab air filter
2. Fuel filter
3. Engine air filter
4. Engine oil filter
5. Master disconnect switch
6. Hydraulic oil filter
7. Batteries

CAT AFTERMARKET SOLUTIONS



MAINTENANCE AND CAT PARTS

Get the most out of your investment by maintaining your dozer with genuine Cat parts—the only parts designed specifically for your machine. Increase uptime and ensure optimum performance from your equipment.

CAT UPGRADES AND TECHNOLOGY

Upgrade your machine based on your needs in the field. From improving safety with Cat Command that allows operators to run a dozer remotely, to increasing productivity with dozer grade technology, explore the full range of upgrades for your dozer at your local Cat dealer.

CAT DEALER SERVICE

Cat machine customers are supported by the largest, most experienced dealer network in the industry. When you work with a Cat dealer, you get more than basic maintenance or parts. You get a personal partner who will do whatever it takes to help you succeed.

CAT CUSTOMER VALUE AGREEMENTS

A Customer Value Agreement helps you control ownership costs over the life of your machine and gives you the peace of mind knowing you have access to genuine Cat parts for replacement, helping you reduce downtime and improve productivity.

TECHNICAL SPECIFICATIONS

See *cat.com* for complete specifications.

ENGINE	
Engine Model	Cat C3.6
Emissions	U.S. EPA Tier 4 Final, Japan 2014 (Tier 4 Final), Korea Stage V, EU Stage V
Build Number	12B
Power Train	Hydrostatic
Net Power* – 2,200 rpm	
SAE J1349	68.8 kW 92 hp
ISO 9249, 80/1269/EEC	68.8 kW 92 hp
Displacement	3.6 L 220 in ³
*Net power is tested per ISO 9249:2007 and SAE J1349:2011 and as advertised is the power available at the flywheel when the engine is equipped with fan, air intake system, exhaust system and alternator.	
Cat U.S. EPA Tier 4 Final, EU Stage V, Japan 2014, and Korea Stage V diesel engines are required to use ULSD (ultra-low sulfur diesel fuel with 15 ppm of sulfur or less) or ULSD blended with the following lower-carbon intensity fuels* up to: 20% biodiesel FAME (fatty acid methyl ester) or 100% renewable diesel, HVO (hydrotreated vegetable oil) and GTL (gas-to-liquid) fuels. Please consult your Cat dealer or “Caterpillar Machine Fluids Recommendations” (SEBU6250) for details.	
Diesel Exhaust Fluid (DEF) used in Cat Selective Catalytic Reduction (SCR) systems must meet the requirements outlined in the International Organization for Standardization (ISO) standard 22241.	
The air conditioning system on this machine contains the fluorinated greenhouse gas refrigerant R134a (Global Warming Potential = 1430). The system contains 1.8 kg (4.0 lb) of refrigerant which has a CO ₂ equivalent of 2.574 metric tonnes (2.837 tons).	
* Tailpipe greenhouse gas emissions from lower-carbon intensity fuels are essentially the same as traditional fuels.	

SERVICE REFILL CAPACITIES		
Fuel Tank	195 L	51.5 gal
Crankcase and Filter	10.5 L	2.8 gal
Final Drives (each side)	10 L	2.6 gal
Final Drives, LGP (each side)	10 L	2.6 gal
Cooling System	19 L	5.0 gal
Transmission/Hydraulic Tank	90 L	23.8 gal
Diesel Exhaust Fluid (DEF) Tank	19 L	4.9 gal

	OPERATING WEIGHT	GROUND PRESSURE
Standard	8338 kg 18,382 lb	39.5 kPa 5.7 psi
LGP	8648 kg 19,066 lb	29.7 kPa 4.3 psi
For machine with ripper, add 554 kg/1,222 lb.		
Specifications shown are for machine equipped with dozer blade, Enclosed Roll Over Protective Structure (EROPS) cab, back up alarm, operator, coolant, lubricants and full fuel tank.		

BLADES	CAPACITY	WIDTH
Standard	1.98 m ³ 2.59 yd ³	2782 mm 109.5 in
LGP	1.85 m ³ 2.42 yd ³	3149 mm 124 in

DIMENSIONS*	STANDARD	LGP
Track Gauge	1550 mm (61.0 in)	1725 mm (67.9 in)
Width of Dozer (standard shoe without blade)	2010 mm (79.1 in)	2360 mm (92.9 in)
Dozer Height	2765 mm (108.9 in)	2765 mm (108.9 in)
Overall Length (with blade)	4281 mm (168.5 in)	4272 mm (168.2 in)
Length of Basic Dozer (without blade)	3290 mm (129.5 in)	3290 mm (129.5 in)
with Ripper Attachment (add to length of basic dozer)	1177 mm (46.3 in)	1177 mm (46.3 in)
Ground Clearance	332 mm (13 in)	332 mm (13 in)
*Abrasion Undercarriage		

Configurations and features may vary by region. Please consult your Cat dealer for availability in your area.

STANDARD & OPTIONAL EQUIPMENT

Standard and optional equipment may vary. Consult your Cat dealer for details.

POWER TRAIN	STANDARD	OPTIONAL
Air cleaner with pre-cleaner, automatic dust ejection and underhood intake	•	
Air cleaner with external pre-cleaner		•
Aluminum bar plate cooling system (radiator, power train)	•	
Automatic traction control	•	
Cat C3.6 diesel engine	•	
Drive, auxiliary	•	
Dual path, closed loop, hydrostatic transmission	•	
Electric fuel pump	•	
Fuel/water separator	•	
Installation, winch		•
Turbocharged aftercooled	•	
ELECTRICAL	STANDARD	OPTIONAL
Alarm, backup	•	
Alternator, 150 amp, heavy-duty	•	
Batteries, heavy-duty, maintenance-free, 1,000 CCA	•	
Diagnostic connector	•	
Four integrated front halogen lights, two rear halogen	•	
Four integrated front LED lights, two rear LED		•
Horn, electric	•	
Starter, electric, 12 V, heavy-duty	•	
UNDERCARRIAGE	STANDARD	OPTIONAL
SALT undercarriage (43 section)	•	
Abrasion undercarriage (38 section)		•
Track Pairs		
Track, 460 mm (18 in)		•
Track, 635 mm (25 in)		•
Carrier rollers	•	
Guards, front/rear guiding	•	
Seven roller track frame	•	
Track adjusters, hydraulic	•	
Track rollers, lifetime-lubricated	•	

HYDRAULIC	STANDARD	OPTIONAL
Hydraulic pump and oil	•	
Four-valve for use with ripper		•
Four-valve for use with winch		•
Single-lever, three-function control	•	
Three-valve hydraulics	•	
CAT TECHNOLOGY	STANDARD	OPTIONAL
Low Slip Traction Control	•	
Slope Indicate	•	
Stable Blade Lift and Tilt	•	
Cat GRADE with Slope Assist™		•
Cat GRADE with 3D		•
Blade Load Monitor (included with Cat Grade with 3D)		•
AutoCarry (included with Cat Grade with 3D)		•
Compatibility with radios and base stations from Trimble, Topcon, and Leica	•	
Capability to install 3D grade systems from Trimble, Topcon, and Leica	•	
Cat Product Link PLE643/PLE743 Cellular	•	
Cat Product Link PLE683/PLE783 Cellular/Satellite		•
Full-color 10-in (254 mm) touchscreen grade display		•
Power Pitch		•
Cat Command Console		•
Cat Command Station		•
ATTACHMENTS	STANDARD	OPTIONAL
Rigid drawbar	•	
Drawbar, towing		•
Front pull device	•	
Machine security system		•
Mounting, winch		•
Ripper, parallelogram, includes three shanks and teeth		•
Winch, hydraulic, high-performance		•
Winch, hydraulic, retrieval		•
OTHER	STANDARD	OPTIONAL
Heater, engine, coolant 120 V/240 V		•
Starting aid, ether		•

Not all features are available in all regions. Please check with your local Cat dealer for specific offering availability in your area.

For additional information, refer to the Technical Specifications brochure available at www.cat.com or your Cat dealer.

STANDARD & OPTIONAL EQUIPMENT

Standard and optional equipment may vary. Consult your Cat dealer for details.

OPERATOR ENVIRONMENT	STANDARD	OPTIONAL
Armrests, adjustable	•	
Cab, with air conditioning		•
Cab, polycarbonate windows and air conditioning		•
Coat hook	•	
Controls, seat-mounted, fore/aft adjustment	•	
Cup holders	•	
Eco Mode	•	
Electronic Monitoring system with gauge: <ul style="list-style-type: none"> – Chassis slope indication – Diesel exhaust fluid (DEF) – Engine coolant temperature – Fuel level – Hydraulic oil temperature 	•	
Electronic security system	•	
Engine air cleaner service indicator	•	
Engine RPM and gear display	•	
Floor mat, rubber, heavy-duty	•	
Foot pads, dash	•	
Hour meter, electronic	•	
Independent forward/reverse speed settings	•	
Mirror, rearview, inside	•	
Power pitch		•
Power port, 12 volt	•	
Radio, AM/FM Bluetooth®		•
ROPS/FOPS canopy	•	
Seat, air-suspended, cloth or vinyl	•	
Seat, air suspension, choice of: <ul style="list-style-type: none"> – Vinyl, heated seat with heated controls – Cloth, heated seat with heated controls – Cloth, heated and ventilated seat with heated controls 		•
Seatbelt, hi-vis retractable 76-mm (3")	•	
Seatbelt buckling indicator/reminder	•	
Single pedal combining decel and brake functions	•	
Sound suppression		•
Speed recall	•	
Storage compartment	•	
Throttle switch, rotary	•	
Travel speed limiter, electronic	•	

Not all features are available in all regions. Please check with your local Cat dealer for specific offering availability in your area.

For additional information, refer to the Technical Specifications brochure available at www.cat.com or your Cat dealer.

D2 DOZER

NOTES

For more complete information on Cat products, dealer services and industry solutions, visit us on the web at www.cat.com.

AEHQ8308-02
Build Number: 12B
(N Am, EU, Aus-NZ, Japan)

© 2024 Caterpillar. All Rights Reserved.

VisionLink is a trademark of Caterpillar Inc., registered in the United States and in other countries.

Materials and specifications are subject to change without notice. Featured machines in photos may include additional equipment. See your Cat dealer for available options.

CAT, CATERPILLAR, LET'S DO THE WORK, their respective logos, "Caterpillar Corporate Yellow," the "Power Edge" and Cat "Modern Hex" trade dress, as well as corporate and product identity used herein, are trademarks of Caterpillar and may not be used without permission.
cat.com caterpillar.com

