



MOTOR GRADER RIG OUT CATALOG

AFTERMARKET COMPONENTS AND COMMON MAINTENANCE PARTS

MODELS: 14, 16, 18, 24
SERIES: GC, M, M3, —

LET'S DO THE WORK.™



AFTERMARKET COMPONENTS

FEATURE UPGRADES	3
ADVANCED CONTROL JOYSTICKS.....	3
AUTO SHIFT.....	4
CAT GRADE SOLUTIONS.....	4
AUTO ARTICULATION.....	5
COLD WEATHER PACKAGE.....	5
E-FENCE: BLADE AVOIDANCE.....	6
POWERED CAB AIR SYSTEM.....	6
CAT PRODUCT LINK™.....	7
DIGITAL BLADE SLOPE METER.....	7
CAT PRODUCTION MEASUREMENT SYSTEM.....	7
MACHINE SECURITY SYSTEM.....	7
REMOTE SERVICES.....	8
POWERED ARM PODS.....	8
FIRE SUPPRESSION.....	8
HIGH PERFORMANCE CIRCLE.....	9

ACCESSORIES	10
REAR VISION WITH CAMERA / MIRRORS.....	11
MIRROR EXTENSIONS.....	11
VISIBILITY ARRANGEMENT.....	11
REAR VIEW CAMERA.....	11
STROKE LIMITING COLLAR.....	12
SY-KLONE AIR CLEANER.....	12
AIR HORN.....	12
FAST FILL FUEL.....	12
SERVICE ACCESS PLATFORM.....	13
PLATFORM LADDER (RHS & LHS).....	13
BASIC DUAL ACCESS PLATFORM.....	13
ENHANCED ACCESS PLATFORM.....	13
AUTO LUBE.....	14
OBJECT DETECTION.....	14
MOLDBOARD PIVOT PIN (LUBRICATED).....	14
METALLIC DCM WEAR STRIPS.....	14

TOOL BOX.....	15
SEAT BELT INDICATOR.....	15
JUMP START CABLES.....	15
BLADE EXTENSIONS.....	16
FRONT AXLE STEERING CYLINDER GUARDS.....	16

ATTACHMENTS	17
PUSH BLOCK.....	18
REAR RIPPER.....	18
TRANSMISSION GUARD.....	18
REAR FENDERS.....	19
REAR FENDERS AND GAURDRAIL.....	19

MODEL 14 SPECIFIC PARTS	20
MODEL 16 SPECIFIC PARTS	22
MODEL 16 GC SPECIFIC PARTS	24
MODEL 18 SPECIFIC PARTS	26
MODEL 24 SPECIFIC PARTS	28

COMMON MAINTENANCE PARTS	31
CUSTOMER VALUE AGREEMENT.....	31
PLANNED MAINTENANCE INTERVALS.....	32
WEAR PARTS – 14.....	34
WEAR PARTS – 16 & 18.....	35
WEAR PARTS – 24.....	35
LIGHT EMITTING DIODE (LED) LIGHTS.....	36
GROUND ENGAGING TOOLS – 14FT BLADES.....	37
GROUND ENGAGING TOOLS – 16FT BLADES.....	38
GROUND ENGAGING TOOLS – 18FT BLADES.....	39
GROUND ENGAGING TOOLS – 24FT BLADES.....	40
GROUND ENGAGING TOOLS – 28FT BLADES.....	40
GRADER BIT SYSTEM.....	41
LINKAGE PIN INFORMATION.....	45

PART NUMBER INDEX	51
--------------------------------	-----------





FEATURE UPGRADES »

Start with the best in efficiency, effectiveness and power – and then make it even better with upgrades that enhance our most popular features. From the latest generation of advanced control joysticks to satellite linked telematics, these feature upgrades make the connection between operator and equipment more intuitive, responsive and flexible than ever.

Advanced Control Joysticks

Meet the next generation of joysticks that enable operators to keep their hands on the controls at all points of operation. These joysticks add all-grade control functions and attachment controls to the existing joysticks and can be programmed to control any auxiliary attachments added to the machine.

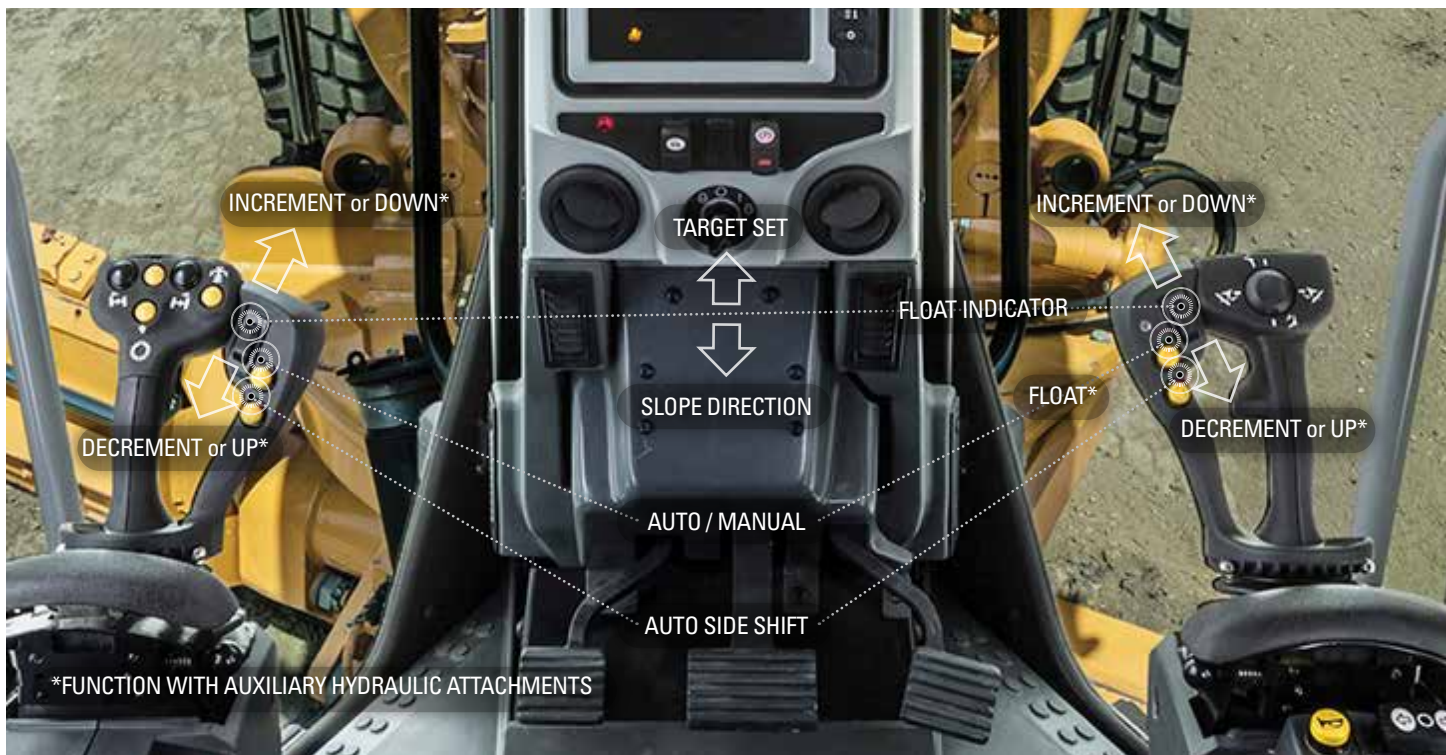

Auto Shift

Automatically shifts the transmission at optimal shift points without operator input.



Cat Grade Solutions

Cat Grade systems are deeply integrated into each machine, so they are easy and intuitive to operate. These productive systems help bring inexperienced operators up to speed quickly, while enabling pro-level operators to perform better than ever.



- **Cat Grade Attachment Ready Option (ARO)**
Ensures the machine is ready for 2D and 3D systems with wiring, sensor mounts and blade/moldboard mast brackets.
- **Cat Grade Cross Slope**
Includes ARO and provides the sensors. The Cat Grade 2D control system brings the customer an increase in productivity by up to 40% while reducing their site costs dramatically. The revolutionary Caterpillar solution is factory integrated, sensor-independent and features a suite of products while includes cross slope, sonic, laser Global Positioning System (GPS), and Advanced Tracking Sensor (ATS) technology.
- **Cat Grade 3D**
Built on top of Cat Grade ARO & Cross Slope, the Cat Grade with 3D is an integrated grade control system that enables operators to improve grading efficiency, accuracy, and productivity in both rough grading and finish grading applications. The integrated design positions low profile antennas on the cab, roof and front frame eliminating conventional blade-mounted masts and related cables.

Auto Articulation

Auto articulation seamlessly adds articulation with steering input to simplify operation, improve maneuverability and reduce the turning radius of the machine.



Cold Weather Package

These kits improve cold weather operation by ensuring machines are able to idle in cold weather for an extended period of time without decreased machine performance.



E-Fence: Blade Avoidance

This is specific to motor graders and when it is activated, it prevents the moldboard from contacting the tires, step ladders, and the circle. This eliminates potential damage to the link bar. Great for new and experienced operators. E-Fence is available when the machine is equipped with the 3D Mastless System.



Powered Cab Air System



BENEFITS »

- Powered HVAC precleaner designed to increase fresh air filter life.
- Includes a precharge fan to improve cab fresh-air filter life.
- Increases the fresh-air flow into the cab, increasing cabin pressure

Cat Product Link™

These cellular and satellite-linked Cat telematic offerings enable accurate monitoring of machine location, fuel status, utilization data and product health information at your fingertips.

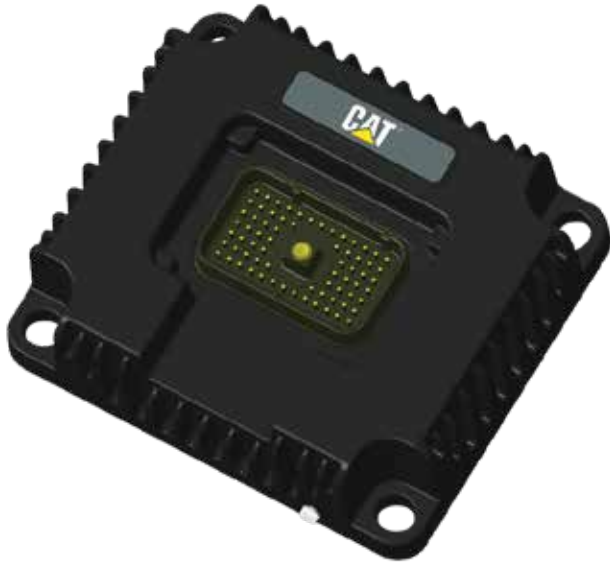

Cat Production Measurement System

Cat Production Measurement (CPM) is built on 2 applications: Efficiency Coach and Application Segmentation. Efficiency coach will save up to 15% fuel. Application segmentation tracks location machine and application of the machine (road, waiting, blading or ripping).

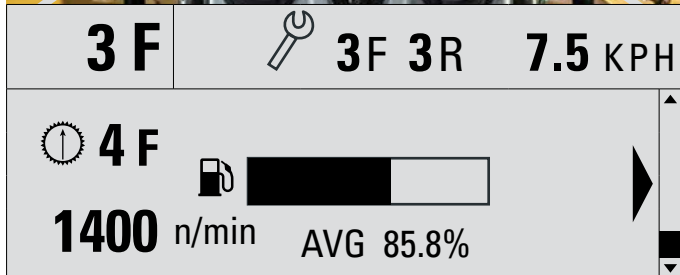

Digital Blade Slope Meter

The digital blade slope meter shows the blade slope angle on the main display. This feature allows the operator to quickly check across slope when the front and rear frame are aligned, and the moldboard is perpendicular to the machine.

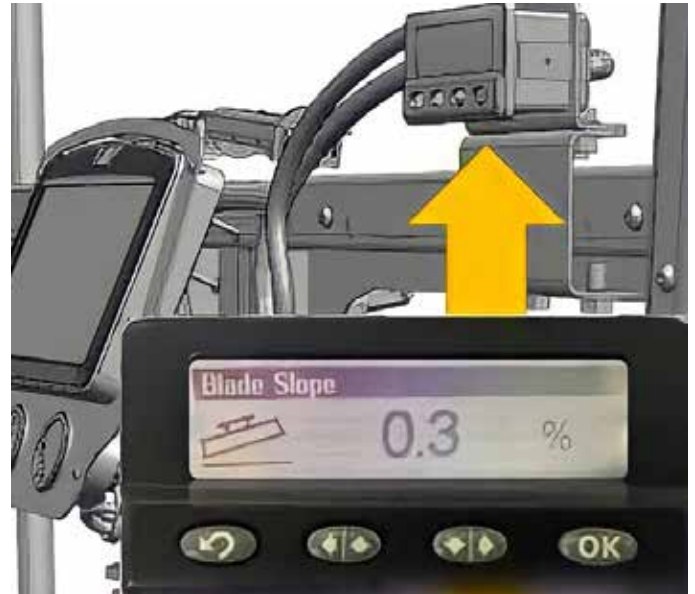

Machine Security System

Machine Security System (MSS) provides a security solution for rental machines, remote worksites, multiple contractor worksites, high theft areas or any situation where limiting machine access is required.



Remote Services

This is a suite of capabilities at your fingertips. This includes remote flash for software updates, remote troubleshooting, and local service using cellular data.



Powered Arm Pods

Powered Arm Pods will provide motorized replacements for adjusting the pod height, allowing the operator to easily change in order to enhance comfort.



Fire Suppression Ready

Enhances machine safety by making it easier for the customer to install and use a fire suppression system. The fire suppression ready system has been developed following major fire suppression providers guidelines and will be able to accommodate most configurations of fire suppression systems recommended for this equipment.



High Performance Circle

Empower your 24 & 24M Motor Grader with the new High Performance Circle, designed to redefine efficiency and precision in grading. Our innovative solution significantly reduces maintenance demands by eliminating wear components, ensuring fewer maintenance touches and extending the life of your circle.

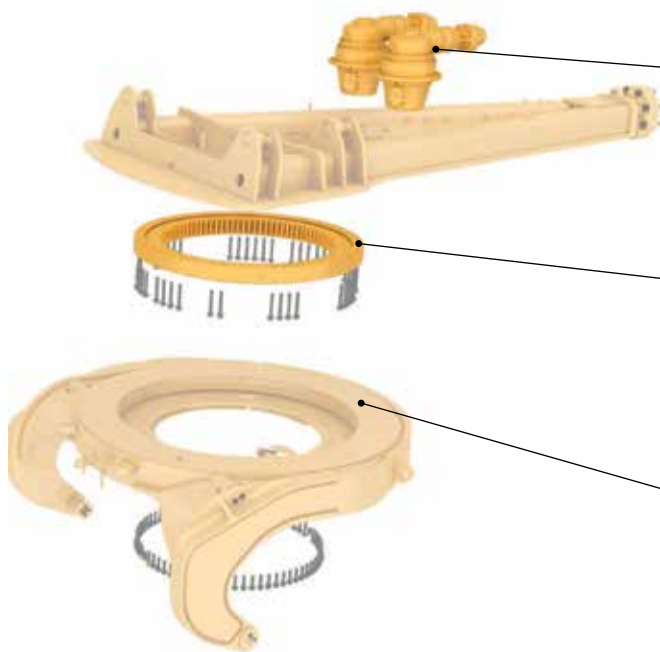

HEAVY DUTY CIRCLE DRIVES WITH SLIP CLUTCH AND BRAKE

- Planetary gear drive (no more brass worm gear)
- 2x life between rebuilds

MAINTENANCE-FREE SWING BEARING

- No adjustments needed and no shims
- Sealed and greased roller bearing
- No brass wear strips
- No more circle segment teeth

FULLY ENCLOSED PINION AND BEARING TEETH

- No debris & elements impacting components
- Greased pinion gear and bearing teeth
- Elimination of circle centering procedure and pinion gear adjustments

ACCESSORIES »

Little things can make a big difference. Sometimes a worn out circle pinion or an iced-over window is all that stands between you and getting a job done. These accessories can give you a little more room in the cab, a better view of what's behind you and the right replacement part at the right time. Best of all, they can give you peace of mind.



Rear Vision with Camera / Mirrors

Provides increased visibility surrounding the machine. Provides a rear vision camera and round convex mirrors that are mounted on outside mirror brackets. *Part of regional arrangement.

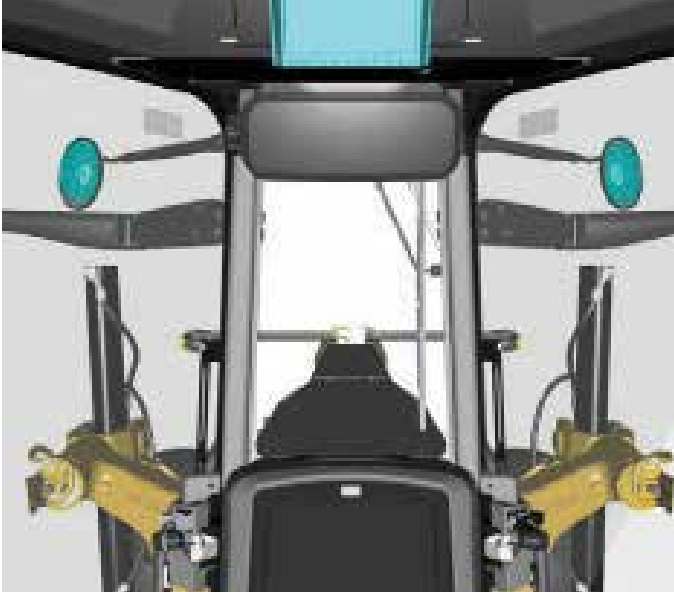

Mirror Extensions

Get the performance of our side mirrors with extensions for expanded visibility. This option is available for standard and heated mirrors.



Visibility Arrangement

Provides two front facing cameras located above the front axle and a cab monitor.



Rear View Camera

The camera is mounted to the rear of the hood and is connected to a dedicated color display mounted in the cab, which shows the view behind the machine. Some come with additional safety features that allow you to always have the display on, or a heated lens on the camera to prevent snow build-up.



Stroke Limiting Collar

The collar reduces the need to repair the frame and drawbar by welding or eventually replacing the drawbar/circle due to damage.



Sy-Klone™ Air Cleaner

You can extend your air filter's life by dramatically reducing the debris that gets through the air intake. That means improved performance and reduced maintenance in heavy snow applications and dusty environments.



Horn, Trumpet

An electronic trumpet horn that can be mounted to the front frame. The electronic trumpet horn has increased sound levels as compared to the standard horn.



Fast Fill Fuel

A fast fill fuel system allows speedy refueling of vehicles and increases operator safety. Fast fill systems in general allow for ground level refueling and automatic shut-off upon a full tank.

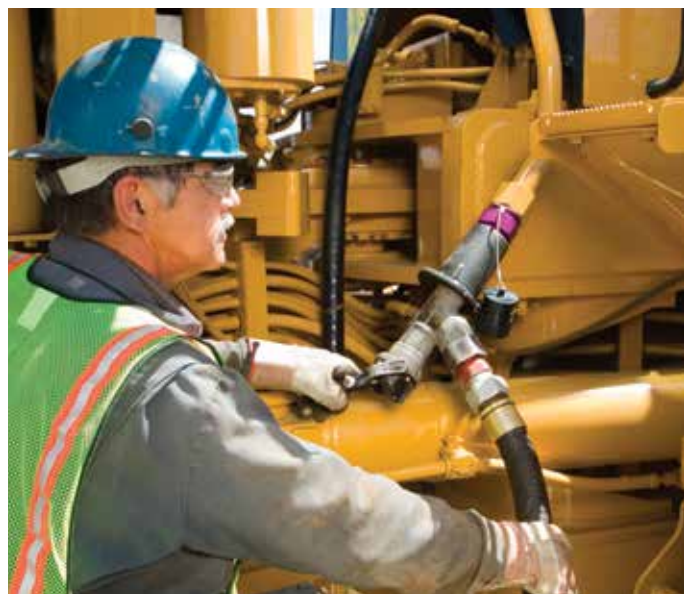

Service Access Platform

The left and right rear enclosure walkways provide access to the rear of the machine and improves visibility.



Platform Ladder

Provides window cleaning platform and two ladders. Ladders are on each side of the cab. Available for right hand side (RHS) and left hand side (LHS).



Basic Dual Access Platform

Provides cab access with LHS/RHS doors, around cab, LHS/RHS platforms and LHS/RHS rear step-up from tandem walkways. Includes emergency egress ladder on LHS platform, movable to RHS platform, as well as front cab window washer platform with bifold guardrail.



Enhanced Access Platform

This optional access platform provides ladder, walkways, handrails and access to the cab from both the left and right side of the machine. This provides a full second access path to the engine compartment and cab of the machine.



Auto Lube

The benefits of automated lubrication include less downtime due to bearing failure, reduced man-hours required for the lubrication task, and increased worker safety, as well as reduced lubricant and cleanup costs.



Object Detection

This is designed to increase safety and visibility during machine startup, initial movement and always in reverse. When radars are active, the system alarms only when the machine is in gear and in the direction of a detected object.



Moldboard Pivot Pin (Lubricated)

Moldboard pivot pin provides this redesign of the moldboard pivot pin. To improve life of our pivot pin and decrease downtime. This new design will keep tolerance tight and prevent premature wear.



Metallic Wear Strips

Drawbar circle moldboard (DCM) Provides metallic wear strips for the circle for severe applications. Includes shimable moldboard wear strip retention system. Recommended for mining application.



Tool Box

The toolbox enhances functionality, enabling operators to carry out a wider range of tasks seamlessly without the need for additional equipment or vehicles. This feature not only maximizes efficiency but also significantly reduces operational costs and downtime.



Seat Belt Indicator

The seat belt indicator ensures safety and compliance for the entire fleet. It uses both audible and visual warnings to remind the operator when the seat belt is not latched.

*Product link compatibility



Jump Start Cables

There are two cables that can be used to provide power to a stalled machine through power receptacles. Select from receptacle to receptacle (machine to machine) or from terminal to receptacle (power pack to machine).



Blade Extensions

Provide up to 20% more productivity with genuine Cat blade extensions.



Front Axle Steering Cylinder Guards

Provides additional protection to the front axle cylinders, lines, and fittings.



ATTACHMENTS »

Cat motor grader attachments are engineered and built for maximum performance. Whatever your business – construction, forestry, landscaping, waste and recycling – the right attachment can help provide a total system solution. From snow plows to blades, Cat attachments maximize the power and productivity of your motor grader.



Rear Ripper

This rear-frame mounted attachment is used for breaking up hard-packed ground or asphalt aggregates in preparation for grading. The ripper shanks are used for heavy ripping; the scarifier shanks are used for light work where maximum surface fracture is desired.



Push Block

The Cat pushblock is mounted to the motor grader nose plate. It acts as both a counterbalance for the rear ripper and as a push point in environments where the motor grader might be used as a push vehicle.



Transmission Guard

Provides a steel guard to protect the transmission from ground debris.

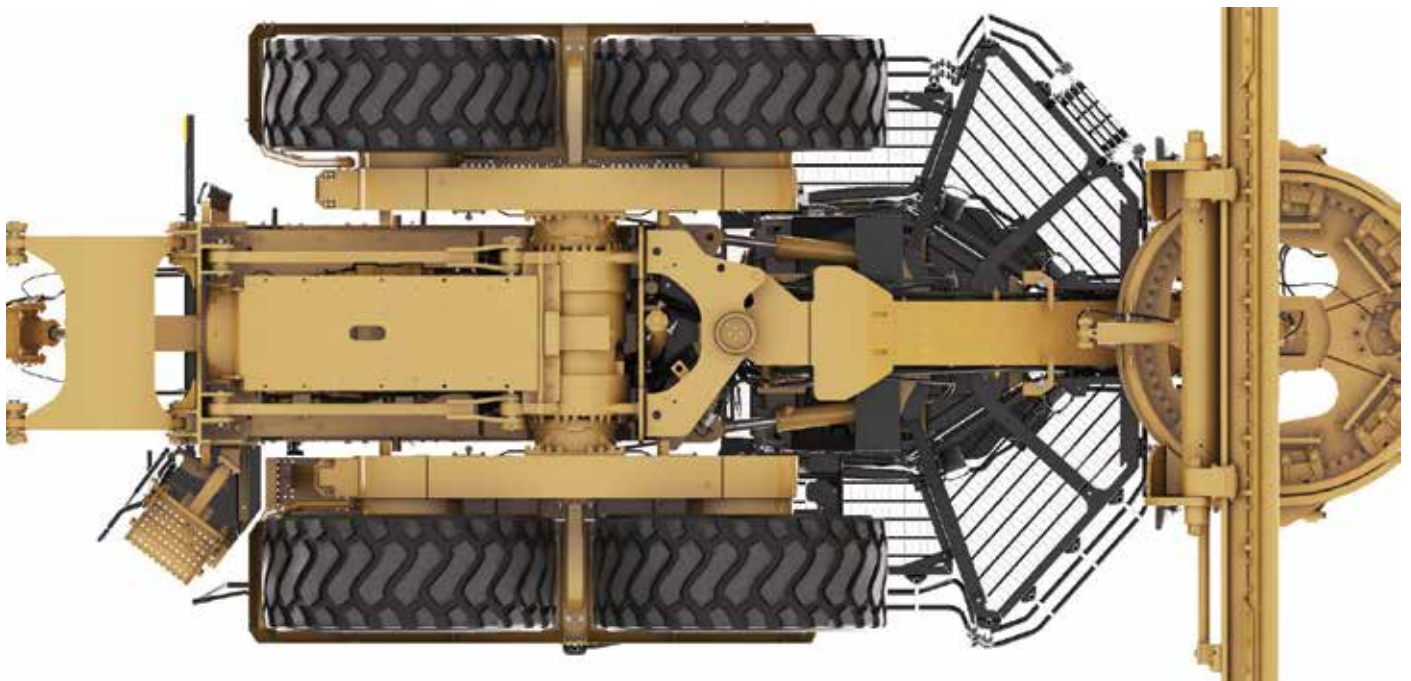

Rear Fenders

Fenders are used to help prevent mud, snow, and debris build up and to protect your equipment. Rear fenders are compatible with all motor grader tire sizes offered by the factory.



Rear Fender and Guardrails

Provides left and right hand tandem fenders with mounted guardrails.



14

MOTOR GRADER

ADDITIONAL UPGRADE OPTIONS



Stable Blade

Stable blade eliminates machine bounce by adjusting the throttle when bounce is detected. This prevents surface damage, improves operator comfort and increases productivity by reducing rework passes.

Heated Cab Glass

Optional heated cab glass makes operation during inclement weather safer and easier.



High Speed Oil Drain

High speed oil drain (HSO) requires pump at service location to be attached to coupling receiver for high speed flow. HSO drain can also manual/gravity drain.

Debris Guard

Provides a shield designed to minimize debris from entering the cooling package. Use in conditions where there would be debris that could enter the engine enclosure compartment and build-up on the cooling package.

16

MOTOR GRADER

ADDITIONAL UPGRADE OPTIONS



Steering Upgrade

Reliability and uptime are improved with these parts required to upgrade the steering group.

Compression Brake

Improves the life of 16 motor grader service brakes operating in extended downhill applications. It will enhance the braking capacity of the machine, reduce the overheating of brake pads, reduce owning and operating costs, and improve machine uptime.



Debris Guard

Provides a shield designed to minimize debris from entering the cooling package. Use in conditions where there would be debris that could enter the engine enclosure compartment and build-up on the cooling package.

Heated Cab Glass

Optional heated cab glass makes operation during inclement weather safer and easier.

16GC

MOTOR GRADER

ADDITIONAL UPGRADE OPTIONS



Auto Lube

The benefits of automated lubrication include less downtime due to bearing failure, reduced man-hours required for the lubrication task, and increased worker safety, as well as reduced lubricant and cleanup costs.

High Speed Oil Drain

High Speed Oil (HSO) Drain requires pump at service location to be attached to coupling receiver for highspeed flow. HSO drain can also manual/gravity drain.



Snow Cover

Recommended for machines operating in extreme Arctic and dry snow conditions. A cover group is provided to help with machines running extended idle times in sub-zero temperatures. An underhood air intake is provided to assist machines operating in heavy snow areas with large amounts of blowing snow.

18

MOTOR GRADER

ADDITIONAL UPGRADE OPTIONS



CPM Application Segmentation

Records on a map when the unit is Blading, Ripping, Roothing, and Waiting.

CPM Efficiency Coach

Displays an icon to the operator when to gear up to maximize fuel efficiency. Fuel savings up to 15% while maintaining load and machine productivity.



Advanced Control Joystick

Improves operational efficiency when utilizing ACCUGRADE or GRADE CONTROL X SLOPE.

Machine Security System (MSS)

Provides a programmable system to manage access to the machine using special MSS keys. Deters theft, vandalism, and unauthorized use.

24

MOTOR GRADER

ADDITIONAL UPGRADE OPTIONS



Transmission Upgrade

This upgrade provides quicker engine response at low idle when using multiple hydraulic functions. The upgrade also provides smoother and quicker shifting uphill and under load while maintaining the original travel speeds.

Steering Upgrade

This upgrade improves the reliability and uptime of the steering system by reducing nuisance faults with improved components.

Radiator Upgrade

This update provides the parts required to upgrade the radiator to Mesabi radiator. This upgrade will provide easier cleanout of the radiator as well as easier repair of the radiator.

Hydraulic Fluid Monitoring

This upgrade detects hydraulic leaks sooner reducing the likelihood of major hydraulic component.



Solar Glass

Cab solar glass will absorb the infrared rays and help in lowering the internal cab temperature, so improving the operator comfort.

Scarifier Bit- Board System

Mounts into the existing ripper shank pockets on all 24 motor graders. This expands machine versatility, without sacrificing the productivity and improves the conditions of your haul roads.

28 ft Moldboard

The new 24's increased power and more robust structures pair perfectly with a longer 28' moldboard. A longer moldboard is ideal for wide haul roads with long passes where machines are assigned for haul road maintenance. The circle drives are protected by the slip clutch independent of moldboard length.

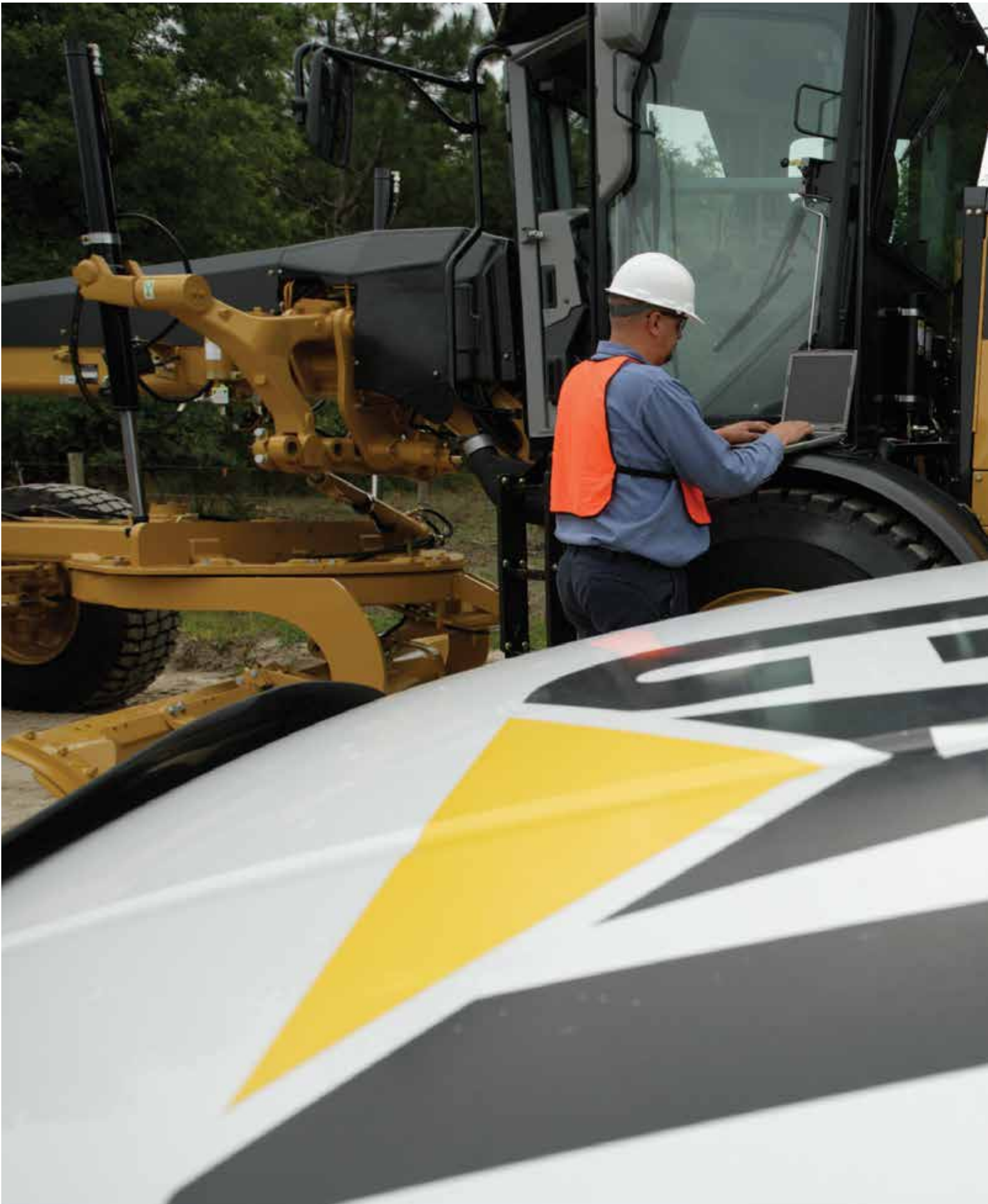



Customer Value Agreements

Every piece of Cat equipment is designed and built to provide maximum productivity and operating economy throughout its working life. Your Cat dealer can help you maintain that built-in value through a Customer Value Agreement (CVA).

What is a Customer Value Agreement?

A CVA is any arrangement between you and your Cat dealer that helps you lower your cost per unit of production. Agreements are tailored to fit your business needs and can range from simple Preventive Maintenance Kits to sophisticated Total Cost Performance Guarantees. No matter which option you choose, you can be assured that your Cat dealer will provide you with careful planning and ongoing attention that will help you succeed.

When you have a CVA with your Cat dealer, you have more time to do what you do best – run your business. Trained dealer technicians assist you by maintaining your equipment and driving down operating costs. In the end, everyone's goal is the same: helping you get more work done at a lower cost.

Perhaps the Most Important Feature of Any CVA is Flexibility.

There are no pre-set requirements or specific products and services that you must agree to buy. In every case and with every piece of equipment, a CVA is an individualized plan. Depending on your needs, your costs can be a flat rate monthly fee or some other arrangement based on actual production hours. Your agreement may include as few or as many pieces of equipment as you wish. You can cover individual systems, single pieces of equipment or entire fleets. Your Cat dealer will work with you to determine the best strategies to maximize productivity and minimize costs for both your Cat equipment and competitive equipment.

Customer Value Agreements are not just for large pieces of equipment, and they are not just for new equipment, either. The need to get more work done at a lower cost is the same, regardless of age or application.

A Partnership That Gets More Done.

In the end, a CVA is a partnership between you and your Cat dealer that will help you succeed by leveraging the equipment management expertise of Caterpillar. When you and your Cat dealer team up with a CVA, you get more than just a piece of Cat iron, you get the company.

PLANNED MAINTENANCE INTERVALS

MOTOR GRADER

		Engine Oil Filter	Air Filter		Fuel Filter Change			Transmission / Lower Power Train	
Sales Model	Serial Number Prefix	Filter Element	Primary Element	Secondary Element	Primary Element	Secondary Element	Tertiary Element	Tandem Breather	Filler Tube Breather
14M	B9J, R9J	1R-1808	380-8941	380-8942	326-1644	1R-0762	1R-0762	4H-6112 (2)	9G-5127
14M3	N9S	1R-1808* 500-0483	386-2099	331-8108	326-1643* 436-7077	1R-0749* 500-0480	1R-0749* 500-0480	4H-6112 (2)	183-3873
	E9S	1R-1808* 500-0483	6I-2505	6I-2506	326-1643* 436-7077	1R-0749* 500-0480	1R-0749* 500-0480	4H-6112 (2)	183-3873
14	NN4,	500-0483	6I-2505	6I-2506	436-7077	500-0480	500-0480	4H-6112 (2)	183-3873
	EN4	500-0483	386-2099	331-8108	436-7077	500-0480	500-0480	4H-6112 (2)	183-3873
	F58	500-0483	386-2099	331-8108	436-7077	500-0480	500-0480	4H-6112 (2)	183-3873
16M	B9H	1R-1808	245-3818	245-3819	326-1644	1R-0762	–	4H-6112 (2)	9G-5127
	R9H	1R-1808	245-3818	245-3819	326-1644	1R-0762	–	4H-6112 (2)	9G-5127
16M3	E9Y	1R-1808* 500-0483	6I-2509	6I-2510	326-1643* 436-7077	1R-0749* 500-0480	1R-0749* 500-0480	4H-6112 (2)	9G-5127
	N9Y	1R-1808* 500-0483	6I-2505	6I-2506	326-1643* 436-7077	1R-0749* 500-0480	1R-0749* 500-0480	4H-6112 (2)	9G-5127
16GC	EB9	500-0483	6I-2509	6I-2510	436-7077	570-1623	570-1623	4H-6112 (2)	183-3873
16	EN5	500-0483	6I-2505	6I-2506	436-7077	500-0480	500-0480	4H-6112 (2)	9G-5127
	NN5	500-0483	6I-2509	6I-2510	436-7077	500-0480	500-0480	4H-6112 (2)	9G-5127
18M3	E9W	1R-1808* 500-0483	6I-2509	6I-2510	326-1643* 436-7077"	1R-0749* 500-0480	1R-0749* 500-0480	4H-6112 (2)	9G-5127
	N9A	1R-1808* 500-0483"	6I-2505	6I-2506	326-1643* 436-7077	1R-0749* 500-0480	1R-0749* 500-0480	4H-6112 (2)	9G-5127
18	EN6	500-0483	6I-2505	6I-2506	436-7077	500-0480	500-0480	4H-6112 (2)	9G-5127
	NN6	500-0483	6I-2509	6I-2510	436-7077	500-0480	500-0480	4H-6112 (2)	9G-5127
24M	B93	1R-1808	380-8941	380-8942	326-1644	1R-0762	–	9T-1119 (2)	4H-6112
	B9K	1R-1808	380-8941	380-8942	326-1644	1R-0762	–	9T-1119 (2)	4H-6112
24	E9Z	1R-1808 (2)	106-3973 (2)	132-7168 (2)	438-5385	1R-0755	1R-0755	9T-1119 (2)	258-2829
	N9Z	1R-1808 (2)	106-3973 (2)	132-7168 (2)	438-5385	1R-0755	1R-0755	9T-1119 (2)	258-2829

*Part number denotes a canister style filter to be used on equipment currently outfitted with canister style filters

**Diesel Particulate Filter

Take care of your motor grader, and it'll take care of you. The list below details your machine's maintenance MAINTENANCE needs, so you can stay current and minimize downtime. It also lists Cat replacement part numbers organized INTERVALS by hour interval — so you'll know what you'll need and when you'll need it.



	Cabin Air		Hydraulic Oil/Filter Change			Engine Crankcase	Diesel Exhaust Fluid			Diesel
Filter Element	Fresh Air Element	Recirculating Element	Filter Element	Pilot Filter	Tank Breather Element	Breather Element	DEF Filter Element	In Tank Filter	Manifold Assembly	***DPF Group
328-3655	149-1912	211-2660	338-3540	1G-8878	9R-9925	9Y-4357	–	–	–	–
328-3655	149-1912	211-2660	338-3540	389-1076	9R-9925	290-8568	378-3187	453-1606	506-5818	390-0679
328-3655	149-1912	211-2660	338-3540	389-1076	9R-9925	290-8568	–	–	–	–
328-3655	149-1912	211-2660	338-3540	389-1076	9R-9925	290-8568	–	–	–	–
328-3655	149-1912	211-2660	338-3540	389-1076	9R-9925	290-8568	378-3187	453-1606	506-5818	535-7853
328-3655	149-1912	211-2660	338-3540	389-1076	9R-9925	290-8568	378-3187	453-1606	506-5818	535-7853
328-3655	149-1912	211-2660	338-3540	1G-8878	9R-9925	9Y-4357	–	–	–	–
328-3655	149-1912	211-2660	338-3540	1G-8878	9R-9925	9Y-4357	–	–	–	–
328-3655	149-1912	211-2660	338-3540	389-1076	9R-9925	290-8568	–	–	–	–
328-3655	149-1912	211-2660	338-3540	389-1076	9R-9925	290-8568	378-3187	453-1604	506-5818	425-0385
328-3655	231-4487 (4)	7T-7358	519-9926		346-8340	290-8568	–	–	–	–
328-3655	149-1912	211-2660	338-3540	389-1076	9R-9925	290-8568	378-3187	453-1604	506-5818	535-7857
328-3655	149-1912	211-2660	338-3540	389-1076	9R-9925	290-8568	–	–	–	–
328-3655	149-1912	211-2660	338-3540	389-1076	9R-9925	290-8568	–	–	–	–
328-3655	149-1912	211-2660	338-3540	389-1076	9R-9925	290-8568	378-3187	453-1604	506-5818	425-0385
328-3655	149-1912	211-2660	338-3540	389-1076	9R-9925	290-8568	378-3187	453-1604	506-5818	535-7858
328-3655	149-1912	211-2660	338-3540	389-1076	9R-9925	290-8568	–	–	–	–
328-3655	231-0167	7T-7358	338-3540	1G-8878	–	455-3837	–	–	–	–
328-3655	231-0167	7T-7358	338-3540	1G-8878	–	455-3837	–	–	–	354-1292
337-5270	457-2836	7T-7358	338-3540	389-1079	507-0644	4W-3027 (2)				
337-5270	457-2836	7T-7358	338-3540	389-1079	507-0644	4W-3027 (2)				

WEAR PARTS »

When machines work as hard as Cat motor graders do, there's going to be wear and tear. Replacing and maintaining certain smaller parts can protect and preserve more critical components. Spares for these parts are good to have around, because fixing little problems before they become big ones keeps costs down and productivity up.

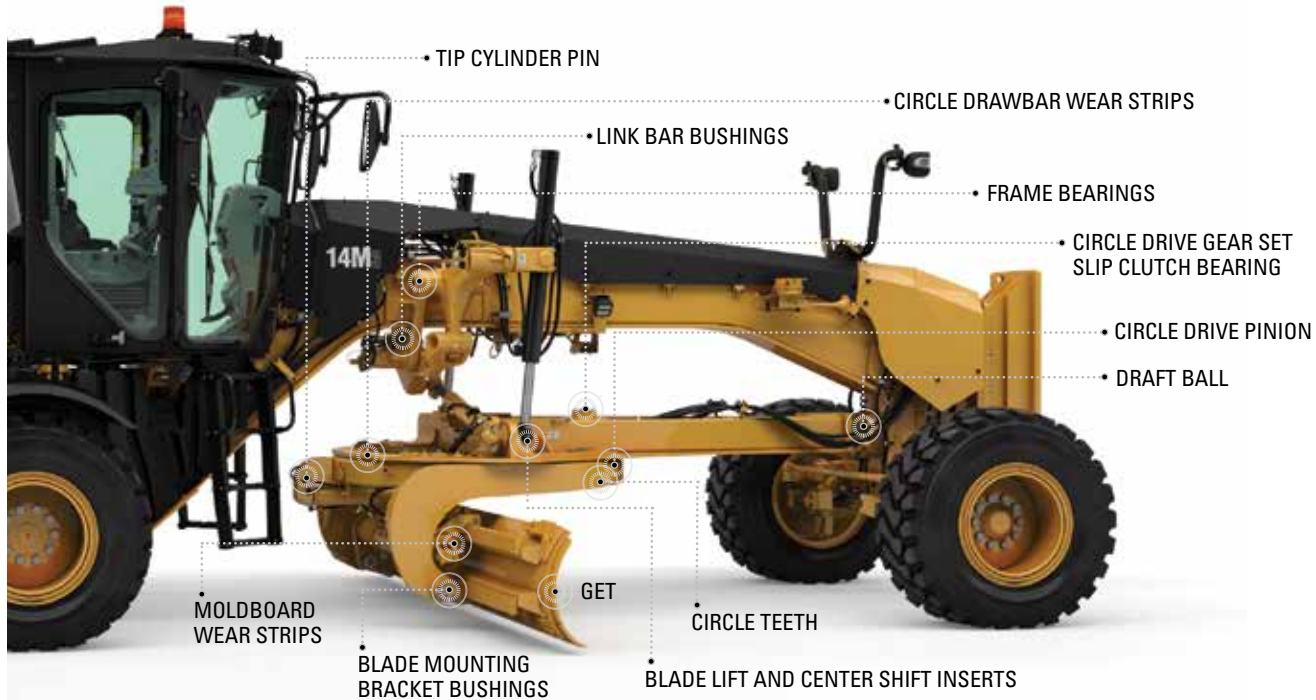

MODEL	DESCRIPTION	QTY	PART NUMBER	PART DESCRIPTION
14	Blade Lift Inserts	4	308-0541	Standard: Blade Lift Inserts
		4	385-6139	General Duty: Blade Lift Inserts
		4	575-5623	Long Life: Blade Lift Inserts
		8	308-0540	Blade Lift Shims (.5mm)
	Circle	6	302-6331	Non Metallic: Wear Strip (top of circle)
		6	352-1002	Metallic: Wear Strip (top of circle)
		42	185-7115	Shim (.5mm)
		12	257-4932	Shim (0.25 mm)
		6	302-6333	Shim (5 mm)
		6	302-6332	Shim (10 mm)
		6	308-6303	Non Metallic: Circle shoe wear strip
		6	6G-4372	Metallic: Circle shoe wear strip
		6	380-7416	General Duty: Circle shoe wear strip
		4	8W-4167	Standard: Bushing
		4	574-2091	Long Life: Bushing
		Moldboard Adjustment Components	4	269-8248
	4		253-4629	End Plates (Lower) (2 Bolt)
	16		8C-6854	Wear Strip Retainer Bolts (2 Bolt)
	16		285-6124	Wear Strip Retainer Washers (2 Bolt)
	4		449-1750	End Plates (Upper) (3 Bolt)
	4		449-1751	End Plates (Upper) (3 Bolt)
	12		7X-0481	Wear Strip Retainer Bolts (3 Bolt)
	24		8T-4223	Wear Strip Retainer Washers (3 Bolt)
12	9X-0941	Wear Strip Retainer Lock Nuts (3 Bolt)		

MODEL	DESCRIPTION	QTY	PART NUMBER	PART DESCRIPTION
14	Moldboard Wear Strips (MWS)	2	253-4627	Standard: MWS - Upper (2 Bolt)
		2	253-4628	Standard: MWS - Upper (2 Bolt)
		2	446-1523	Standard: MWS - Lower (2 Bolt)
		2	565-6898	Long Life: MWS - Lower (2 Bolt)
		4	446-1523	Standard: MWS - Upper/Lower (3 Bolt)
		4	565-6898	Long Life: MWS - Upper/Lower (3 Bolt)
		4	642-7008	Long Life: MWS - Upper/Lower (3 Bolt)
		4	642-7009	Long Life: MWS - Upper/Lower (3 Bolt)
16 & 18	Blade Lift Inserts	4	310-5480	Standard: Blade Lift Inserts
		4	580-1081	Long Life: Blade Lift Inserts
		8	310-5479	Blade Lift Shims (.5mm)
	Circle	8	352-1002	Metallic: Wear Strip (top of circle)
		72	185-7115	Shim (.5mm)
		16	257-4932	Shim (0.25 mm)
		8	302-6333	Shim (5 mm)
		8	302-6343	Shim (14 mm)
		6	6G-4372	Metallic: Circle Shoe Wear Strip
		6	380-7416	General Duty: Circle Shoe Wear Strip
		6	8W-4167	Standard: Bushing
		8	361-1694	General Duty: 8W5388 – Oversize OD (4.125mm)
		8	574-2091	Long Life: Bushing
	Moldboard Adjustment Components	4	449-1750	End Plates (Upper)
		4	449-1751	End Plates (Upper)
		12	7X-0481	Wear Strip Retainer Bolts
		24	8T-4223	Wear Strip Retainer Washers
		12	9X-0941	Wear Strip Retainer Lock Nuts
	Moldboard Wear Strips (MWS)	4	2G-2946	Upper Shim (0.76 mm)
		4	2G-2945	Lower Shim (1.52 mm)
4		446-1523	Standard: Upper/Lower Wear Strip	
4		565-6898	Long Life: Upper/Lower Wear Strip	
24	Blade Lift Inserts	22	3G-0911	Blade Lift Shims (0.8mm)
	Circle	16	6G-4524	Wear Strip (top of circle)
		16	380-7417	General Duty: Wear Strip (top of circle)
		32	468-4106	Shim (0.25 mm)
		136	468-4105	Shim (0.8mm)
		8	117-2244	Circle shoe Wear Strip
		2	087-5379	Bushing
	Moldboard Adjustment Components	4	140-8453	End Plates (Upper)
		4	140-8452	End Plates (Lower)
		4	8T-4139	Wear Strip Retainer Bolts
		12	8T-4223	Wear Strip Retainer Washers
	Moldboard Wear Strips (MWS)	6	140-8455	MWS - Upper Shim (0.76 mm)
		6	140-8454	MWS - Lower Shim (1.52 mm)
		2	443-6839	Standard: Wear strip -Upper
		2	565-6899	Long Life: Wear strip -Upper
		2	443-6838	Standard: Wear strip -Upper
2		565-6900	Long Life: Wear strip -Upper	

LED LIGHTS »

Shutting down a machine to change a light bulb may not seem like a big deal, but unexpected downtime is never a good thing. Cat LED work lights don't have filaments that burn out or bulbs that need to be replaced. With more than 40,000 hours of expected life, you can count on them for bright light and increased productivity.

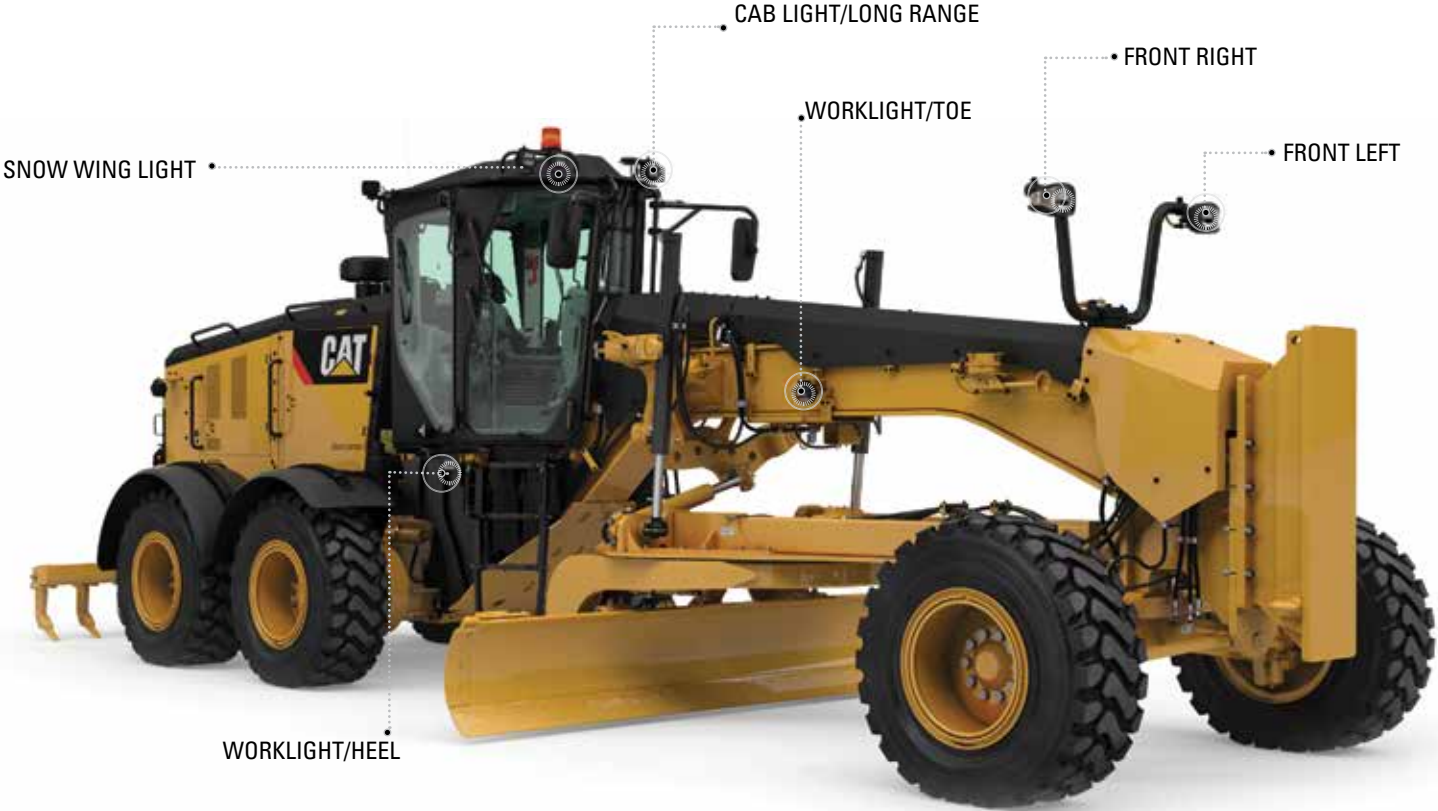

14' Blades

3/4" Bolt Holes

Moldboard Cutting Edges													
Profile	Type	Width Tooth X Gap (mm)	Length	Qty	Hardware	Thickness				End Bits	Hard- ware	Overlay	Hardware
						16mm	19mm	25mm	35mm				
Curved	Standard	6"	7'	2	15	9J-3658				8E-5529	5	6Y-2805	4
		8"				7D-1158	7D-1577	4T-2233					
	Yellowmark™	6"					4Z-8785						
		8"				7T-1626	7T-1624	7T-1625					
	Serrated	8" - 36X25					283-1068	311-7674					
		8" - 51X26					350-7200						
Flat	Standard	8"	7'	2	15	4T-2970	4T-3032	7T-3494		5	N/A	N/A	
		10"					4T-6508	4T-8316					
	11"					140-6790							
	Serrated	8" - 51X26					350-0180						
		10" - 56X33						4Z-8055	4Z-8346				

Carbide Edges													
Type	Width	Length	Qty	Hard- ware	Adapter Board	Bits per Board	Shank Size	Bits	Notes				
Curved	Tungsten Carbide	4.75"	2'	4	5				8E-5529	5	135-9369	4	
		3'	2	7		208-8863							
	6.75"	3'	2	7		217-4698							
	4'	2	9		217-4699								
Tung. Carbide Serrated	6.75" - 62X40	2'	4	5				208-8865			135-9370	4	
	6.75" - 62X40	3'	2	7				217-4697					
Flat	Carbide Insert	6"	3'	5	6			330-9491					
			4'	2				286-3148					

Specialty													
Type	Width	Length	Qty	Hard- ware	Adapter Board	Bits per Board	Shank Size	Bits	Notes				
Rotating Bit	5.9"	3'	2	7	307-2613	21			571-0532	1"	571-0533		
		4'	2	9	307-2615	28	7/8"						
	7.2"	3'	2	7	323-1251	21							
		4'	2	9	321-4272	28							

GraderBit2™ System														
Type	Part Number	Name	Length	Hardware	Bits per Board	Adapters per Moldboard	Bit Part Number	Bit Part Name	Width (mm)	Notes				
GraderBit2™	552-8520	Left Hand Adapter Board	2'	5	10	2	552-8524	Penetration Bit	15		552-8524	552-8525	552-8526	552-8527
							552-8525	Sharp Bit	20					
							552-8526	Standard Bit	30					
	552-8527	Wide Bit	60											
	552-8522	3' Center Adapter Board	3'	6	15	2	552-8528	Standard Mining Bit	30					
							552-8529	Wide Mining Bit	60					
552-8523	Right Hand Adapter Board	2'	4	10	2	560-8840	SnowBit	60		552-8528	552-8529	560-8840	563-1186	
609-2917	Universal Adapter Board	2'	Various	10		563-1186	BoreSaver	-						

Auxiliary Blade Cutting Edges													
Profile	Type	Width	Length	Qty	Hardware	Thickness				Notes			
						13mm	16mm	19mm	25mm				
Front Mount Blades	9 ft Blade	8"	26"	2	4					uses 3/4" bolts			
			56"	1	9								
	8 ft Blade	18.2"	2	3					4T-3010				
61.3"		1	10					169-4089					
9'7" Foldable	8"	18.2"	2	3				4T-8353					
		78.8"	1	13				4T-2315					
2' Extension	Curved	6"	24"	1	4			3G-2166	3G-2165		LH: 265-6743 RH: 265-6744		





Rippers / Scarifiers													
Adapter Size	Shanks		Quantity	Bolts	Nuts	Washers	Pin	Retainer	Misc				
	Type	Part Number											
Rear Mount R300	Straight	9J-6586	30	5J-4773	2J-3506	5P-8248	136-8308	114-0359	Repair Nose 8E-7300				
	Curved	9J-8913											
Scarifier V-Block ⁴	Standard	195-7218	8	5F-8933	5K-1459	5K-1458	5K-1458	Tip Removal Tool 6B-3260					
	Long	7D-4501											
Scarifier Straight Block ⁵	Standard	195-7219	4	5J-4773	2J-3506	5P-8248	5K-1459	5K-1458	Tip Removal Tool 6B-3260				
	Long												

Hardware and Wear Protection													
Type	Application	Hardware	Quantity	Bolts	Nuts	Washers	Notes						
Hardware	Standard Edges	Bolts	3/4-10 x 2-1/2	30	5J-4773	2J-3506	5P-8248						
	Specialty	Bolts	3/4-10 x 2-3/4	30	5J-4771								
	End Bits	Bolts	3/4-10 x 2-1/2	10	5J-4773								
	Overlays	Bolts	3/4-10 x 3-3/4	8	5F-8933								
	Front Blade	Bolts	3/4-10 x 2-1/4	see above	4F-7827								
	Extension	Bolts	3/4-10 x 2-1/4	4	5J-4773								
Wear Protection	Moldboard Plate	13.5" Radius	4D-5821	2									Inspect moldboard for excess wear. Ensure moldboard and new edges are free from paint and debris. Torque 3/4" Nuts to 350 +/- 45 ft. lb.
		16.25" Radius	8W-5266	2									

⁴Front Notched ⁵Rear Notched *ARM -Abrasion Resistant Material **MAO -Made as Ordered

16' Blades

3/4" Bolt Holes

Moldboard Cutting Edges																											
Profile	Type	Width Tooth X Gap (mm)	Length	Qty	Hardware	Thickness				End Bits	Hard- ware	Overlay	Hardware														
						19mm	25mm	35mm	45mm																		
Curved	Standard	8"	8'	2	17	7D-1949	4T-2236			16mm 8E-5529 ³	5	6Y-2805	4														
	Std. A.R.M.						375-9887																				
	Yellowmark™						489-6705																				
	Serrated	8" - 50X26 8" - 36X25 8" - 62X40				350-7202 217-4821 217-4834																					
Flat	Standard	8"	8'	2	17	4T-3037	7T-3495				5	N/A	N/A														
		10"					4T-6511	4T-8317	104-3628																		
		11"					140-6832 ²	132-1086																			
		12"						4Z-9188	128-2577																		
	Std. A.R.M.	10"			195-7177				554-0845																		
		13"			489-6706				554-0846																		
	Serrated	10" - 57X33 10" - 62X41 10" - 58X51 10" - 60X60 10" - 78X69 10" - 102X77 10" - 130X57	8'	2	17	17	4Z-8056	100-4581 253-0198 350-0182 350-0183 350-0184	104-3631 552-8124					357-3123	5	N/A	N/A	N/A									
																			13" - 90X38.5	8'	2	17			134-1778		
																			10" - 60X60	8'	2	17			554-0848		
																			Carbide Edges								
Curved										Tungsten Carbide	4.75"	2'	8						5	208-8863				16mm 8E-5529 ³	5	135-9369	4
											6.75"	4'	4						9	208-8866							
Flat	Tung. Carbide Serrated	6.75" - 62X40	2'	8	5	208-8865				19mm 8E-5530 ⁴	5	N/A	N/A														
														Flat	Carbide Insert	6"	4'	4	6	286-3148					N/A	N/A	
Specialty																											
Type	Width	Length	Qty	Hard- ware	Adapter Board	Bits per Board	Shank Size	Bits	Notes																		
Rotating Bit	5.9"	4'	4	9	307-2615	28	7/8"	571-0532																			
	7.2"	4'	4	9	321-4272	28	1"	571-0533																			
GraderBit2™ System																											
Type	Part Number	Name	Length	Hardware	Bits per Board	Adapters per Moldboard	Bit Part Number	Bit Part Name	Width (mm)	Notes																	
GraderBit2™	552-8520	Left Hand Adapter Board	2'	5	10	2	552-8524	Penetration Bit	15		552-8524	552-8525	552-8526	552-8527													
							552-8525	Sharp Bit	20																		
							552-8526	Standard Bit	30																		
							552-8527	Wide Bit	60																		
	552-8521	2' Center Adapter Board	2'	4	10	4	552-8528	Standard Mining Bit	30																		
							552-8529	Wide Mining Bit	60																		
	552-8523	Right Hand Adapter Board	2'	4	10	2	560-8840	SnowBit	60																		
							563-1186	BoreSaver	-						552-8528	552-8529	560-8840	563-1186									
609-2917	Universal Adapter Board	2'	Various	10																							
Type	Part Number	Angle	Length	Quantity																							
Angling Plate	552-9410	0°	1'	16																							
	552-9411	5°																									
	552-9412	10°																									
	552-9413	15°																									
	552-9414	20°																									
	552-9415	25°																									
	552-9416	30°																									
Auxiliary Blade Cutting Edges																											
Profile	Type	Width	Length	Qty	Hardware	Thickness				Notes																	
Front Mount Blades	9 ft. Blade	8"	26" 56"	2 1	4 9	13mm	16mm	19mm	25mm	uses 3/4" bolts 																	
	8 ft. Blade	8"	18.2"	2	3																						
			61.3"	1	10																						
2' Extension ¹	Curved	8"	18.2" 78.8"	2 1	3 13					LH: 281-9455 RH: 456-4448																	
			24"	1	4			3G-2166	3G-2165																		
Hardware and Wear Protection																											
Type	Application	Hardware	Quantity	Bolts	Nuts	Washers	Notes																				
Hardware	Standard Edges ²	160H/M, 14H/M	3/4-10 x 2-1/2	34	5J-4773	2J-3506	5P-8248	Inspect moldboard for excess wear Ensure moldboard and new edges are free from paint and debris. Torque 3/4" Nuts to 350 +/- 45 ft. lb.																			
	Specialty ³		3/4-10 x 2-3/4	34	5J-4771																						
	End Bits ²		3/4-10 x 2-1/2	10	5J-4773																						
	Standard Edges & Specialty ⁴	16H/M	3/4-10 x 3-1/8	20	1J-6762																						
			3/4-10 x 3-3/4	14	5F-8933																						
	End Bits ⁴	160H/M, 14H/M	3/4-10 x 3-1/8	4	1J-6762																						
			3/4-10 x 3-3/4	6	5F-8933																						
	Overlays		3/4-10 x 3-3/4	8	5F-8933																						
	Front Blade		3/4-10 x 2-1/4	see above	4F-7827																						
	Extension		3/4-10 x 2-1/4	4	5J-4773																						
Wear Protection	Moldboard Plate	16.25" Radius	385-6748	2																							

*ARM -Abrasion Resistant Material **MAO -Made as Ordered

¹Used on 160H, 160M

²Used on 160H, 160M, 14H, 14M

³Used on 16H, 16M



⁴Front Notched

⁵Rear Notched

⁶Single Bev

18' Blades

3/4" Bolt Holes

Moldboard Cutting Edges														
Profile	Type	Width Tooth X Gap (mm)	Length	Qty	Hardware	Thickness				End Bits	Hard- ware	Overlay	Hardware	
						19mm	25mm	35mm	45mm					
Curved	Standard	8"	6'	3	13		4T-2231				5	6Y-2805	4	
	Std. A.R.M.	8"	6'	3	13		554-0852							
	Serrated	8" - 62X40	6'	3	13		521-2870							
	Serr. A.R.M.	8" - 62X40	6'	3	13		554-0853							
Flat	Standard	8"	6'	3	13		7T-3493				5	N/A	N/A	
		10"					4T-6502	440-5352	521-2871					
	Std. A.R.M.	13"	6'	3	13			521-2872	521-2873					
		Serrated	10" - 62X40	6'	3	13			554-0847					
		Serr. A.R.M.	10" - 62X40	6'	3	13			521-2874					521-2875
		Serr. A.R.M.	10" - 62X40	6'	3	13			554-0850					

Carbide Edges													
Curved	Tungsten Carbide	4.75"	2'	6	5	208-8863					5	135-9369	4
			3'	4	7	217-4698							
		6.75"	2'	6	5	195-7266						135-9370	4
			3'	4	7	195-7267							
	Tung. Carbide Serrated	6.75" - 62X40	2'	6	5		208-8865					N/A	N/A
			3'	4	7		217-4697						
Flat	Tung. Carbide	6"	3'	4	5	330-9491							

Specialty										Notes
Type	Width	Length	Qty	Hard- ware	Adapter Board	Bits per Board	Shank Size	Bits		
Rotating Bit	5.9"	3'	6	7	307-2613	21	7/8"	571-0532		
	7.2"	3'	6	7	323-1251	21	1"	571-0533		

GraderBit2™ System										
Type	Part Number	Name	Length	Hardware	Bits per Board	Adapters per Moldboard	Bit Part Number	Bit Part Name	Width (mm)	Notes
GraderBit2™	552-8520	Left Hand Adapter Board	2'	5	10	3	552-8524	Penetration Bit	15	
							552-8525	Sharp Bit	20	
							552-8526	Standard Bit	30	
							552-8527	Wide Bit	60	
	552-8521	2' Center Adapter Board	2'	4	10	3	552-8528	Standard Mining Bit	30	
							552-8529	Wide Mining Bit	60	
	552-8523	Right Hand Adapter Board	2'	4	10	3	560-8840	SnowBit	60	
							563-1186	BoreSaver	-	
	609-2917	Universal Adapter Board	2'	Various	10					

Auxiliary Blade Cutting Edges										
Profile	Type	Width	Length	Qty	Hardware	Thickness				Notes
						13mm	16mm	19mm	25mm	
Front Mount Blades	9 ft Blade	8"	26"	2	4			4T-3010		uses 3/4" bolts 
			56"	1	9			169-4089		
	8 ft Blade	8"	18.2"	2	3			4T-8353		
			61.3"	1	10			4T-2315		
9'7" Foldable	8"	18.2"	2	3			4T-8353			
		78.8"	1	13			4T-8378			

Hardware and Wear Protection										
Type	Application	Hardware	Quantity	Bolts	Nuts	Washers	Notes			
Hardware	Standard Edges ¹	Bolts	3/4-10 x 3-1/8	21	1J-6762	2J-3506	5P-8248	Inspect moldboard for excess wear Ensure moldboard and new edges are free from paint and debris. Torque 3/4" Nuts to 350 +/- 45 ft. lb.		
	Specialty		3/4-10 x 3-3/4	18	5F-8933					
	End Bits ²		3/4-10 x 3-3/4	36	5F-8933					
	Overlays		3/4-10 x 3-1/8	4	1J-6762					
			3/4-10 x 3-3/4	6	5F-8933					
Wear Protection	Moldboard Plate	16.7" Radius	136-2541	1						

¹The middle 21 bolt holes use bolt 1J-6762 the outside 9 on each side of the moldboard use bolts 5F-8933

²The top two bolt holes of each end bit use bolt 1J-6762 the bottom three bolt holes of each end bit use bolt 5F8933

³Multiple tooth spacing options available

*ARM -Abrasion Resistant Material **MAO -Made as Ordered

24' Blades

1" Bolt Holes

Moldboard Cutting Edges													
Profile	Type	Width Tooth X Gap (mm)	Length	Qty	Hardware	Thickness				End Bits	Hardware	Overlay	Hardware
						28mm	45mm	60mm	75mm				
Flat	Standard	13"	4'	6	9	109-3117	109-3116	132-1019			6	N/A	N/A
		16"		3		17	135-9690	138-6440	135-9349				
	Std. A.R.M.	13'	4'	6	9			484-2302					
		16"	4'	6	9			559-1162					
	Serrated	13" - 61X40	4'	6	9			438-1337	286-2022				
		16" - 61X41					138-6542	132-4753					
		16" - 83X51						135-9796	135-9797				
		16" - 101.6X51						356-0889					
		16" - 140X64						365-5079					
	Serr. A.R.M.	16" - 95X57	8'	3	18				424-7737				
16" - 101.6X51		4'	6	9			365-5083						
Specialty													
Type	Bit Spacing	Width	Length	Qty	Hardware	Adapter Board	Bits per Board	Bits 40mm	Notes				
Mining Bit	Wide Gap	7.75"	3'	8	7	178-4095	10	357-9643					
Rippers / Scarifiers													
Adapter Size	Shanks		Protectors	Tips			Pin	Retainer	Misc.				
	Type	Part Number	Standard	Type	Std	A.R.M.							
Rear Mount R350	Straight	484-8282	138-0796	Pin-On	Penetration	6Y-0359	159-0356	114-0358	114-0359	Repair Nose 8E-7350			
					Centerline	6Y-0352	159-0355						
					Penetration	472-0825	-	473-3816	-				
					Centerline	472-0824	-		-				
Hardware and Wear Protection													
Type	Application	Hardware	Quantity	Bolts	Nuts	Washers	Notes						
Hardware	Edges	Bolts	1-8 x 4-1/2	10	1J-3527		Torque 1" nuts to 850 +/- 110 ft. lb.						
	End Bits	Bolts	1-8 x 3-1/4	44	4J-9058	2J-3507							5P-8250
	Specialty	Bolts	1-8 x 4-1/2	12	1J-3527								
Wear Protection	Moldboard Plate	21.65" Radius	139-2404	1	1J-3527								

28' Blades

1" Bolt Holes

Moldboard Cutting Edges													
Profile	Type	Width Tooth X Gap (mm)	Length	Qty	Hardware	Thickness				End Bits	Hardware	Overlay	Hardware
						28mm	45mm	60mm	75mm				
Flat	Standard	13"	4'	7	9	109-3117	109-3116	132-1019			6	N/A	N/A
		16"		3		17	135-9690	138-6440	135-9349				
	Std. A.R.M.	13'	4'	7	9			559-1162					
		16"	4'	7	9			438-1337	286-2022				
	Serrated	13" - 61X40	4'	7	9			438-1337	286-2022				
		16" - 61X41					138-6542	132-4753					
		16" - 83X51						135-9796	135-9797				
		16" - 101.6X51						356-0889					
		16" - 140X64						365-5079					
	Serr. A.R.M.	16" - 101.6X51	4'	7	9			365-5083					
Rippers / Scarifiers													
Adapter Size	Shanks		Protectors	Tips			Pin	Retainer	Misc.				
	Type	Part Number	Standard	Type	Std	A.R.M.							
Rear Mount R350	Straight	484-8282	138-0796	Pin-On	Penetration	6Y-0359	159-0356	114-0358	114-0359	Repair Nose 8E-7350			
					Centerline	6Y-0352	159-0355						
					Penetration	472-0825	-	473-3816	-				
					Centerline	472-0824	-		-				
Hardware and Wear Protection													
Type	Application	Hardware	Quantity	Bolts	Nuts	Washers	Notes						
Hardware	Edges	Bolts	1-8 x 4-1/2	63	1J-3527	2J-3507	5P-8250	Torque 1" nuts to 850 +/- 110 ft. lb.					
	End Bits	Bolts	1-8 x 4-1/2	12	1J-3527	2J-3507	5P-8250						
	Specialty	Bolts	1-8 x 4-1/2	63	1J-3527	2J-3507	5P-8250						
Wear Protection	Moldboard Plate	21.65" Radius	568-5679	2									

GRADERBIT2™ SYSTEM »

GraderBit2 System is ideal for finish grading, maintaining roadways or reconditioning haul roads. Tungsten carbide cutting bits deliver up to 20x wear life of through-hardened cutting edges. 7 different bit designs can form a continuous edge or 10 serration patterns that allow pass-through of 15 to 60mm aggregate.

CAT GRADERBIT2™ SYSTEM CONFIGURATOR					
PART #	PART NAME	LENGTH	14' MOLDBOARD	16' MOLDBOARD	18' MOLDBOARD
552-8520	Left Hand Adapter Board	2'	2	2	3
552-8521	2' Center Adapter Board	2'	0	4	3
552-8522	3' Center Adapter Board	3'	2	0	0
552-8523	Right Hand Adapter Board	2'	2	2	3
Number of Angling Plates Needed			14	16	18
Number of Bits Needed			60	70	80

Bit boards that are built to perform in your application

Grooves cast into the boards accept weld overlay or material packing in order to extend board wear life, while installing and removing the boards is made easier through pre-drilled lifting eye holes. Adaptor boards feature an off-set design that ensures optimal bolted joint strength and consistent bit placement.



GRADERBIT2™ SYSTEM »

Bits are installed effortlessly with no tools thanks to pull-ring pin that inserts into the bit shaft and locks over the bit. Bit Life is optimized at any cast angle thanks to Angling plates that always keep the bits facing the direction of travel.

ANGLING PLATES			
PART #	DESCRIPTION	ANGLE	LENGTH
552-9410	Angling Plate	0°	1'
552-9411	Angling Plate	5°	1'
552-9412	Angling Plate	10°	1'
552-9413	Angling Plate	15°	1'
552-9414	Angling Plate	20°	1'
552-9415	Angling Plate	25°	1'
552-9416	Angling Plate	30°	1'

ANGLING PLATES	
PART #	DESCRIPTION
132-3812*	Pull Ring
562-9545	Bearing Sleeve

*For service replacement only. Pull rings are included with bits.

Retention that installs without tools and adjusts to your grading conditions



- Bushings reduce board damage during extreme operations and can be replaced to extend board life
- The bit shaft fits into the angling plate to prevent bits from rotating. 7 plate options allow for a 0 to 30 Blade cast angle in 5 increments.
- The pull-ring pin makes bit installation / removal easy without the need for tools.
- Angle plates keep the carbide facing direction of travel to reduce erosion of the bit body, which can reduce bit life.



7 different bit designs can form a continuous edge or 10 serration patterns that allow pass-through of 15 to 60mm aggregate. Serration patterns remove holes and ridges from compacted surfaces. Wide or SnowBit™ create a continuous edge the system can be used for finish grading.



WIDE

At 63mm wide this bit can be configured as a continuous edge or placed in every other hole for a 2.5" serration pattern.



WIDE MINING

63mm wide & 12mm taller. Imbedded carbide layer adds 72% more carbide to extends bit life.



STANDARD

30mm, this bit offers a serration pattern that will allow aggregate up to 30mm to pass through.



STANDARD MINING

30mm wide & 12mm taller. Imbedded carbide layer adds 72% more carbide to extends bit life.



SHARP

23mm wide, this bit will help break into hard ground while allowing aggregate size to 37mm to pass through.



SNOW BIT™

63mm wide bull nose carbide insert & steel face. This continuous edge system is impact resistant & designed for paved road snow removal.



PENETRATION

Specially design carbide shape that comes to point and a width of 15mm this bit will help break into any surface.



BORE SAVER™

Used to protect adapter board bore holes when not in use.

GRADERBIT2™ SYSTEM »

SERRATION PATTERNS		
AGGREGATE (MM) PASS-THROUGH	BIT CONFIGURATION	BIT WIDTH
0 in / 0 mm	Wide bits across the board	63 mm
0.6 in / 15 mm	Alternate Wide and Standard bits	63 / 30 mm
0.8 in / 20 mm	Alternate Wide and Sharp bits	63 / 23 mm
1 in / 25 mm	Alternate Wide and Penetration bits	63 / 15.5 mm
1.25 in / 32 mm	Standard bits across the board	30 mm
1.35 in / 34 mm	Alternated Standard and Sharp bit	63 / 23 mm
1.5 in / 38 mm	Sharp bits across the board	23 mm
1.5 in / 38 mm	Alternate Standard and Penetration	30 / 15.5 mm
1.65 in / 42 mm	Alternate Sharp and Penetration bits	23 / 15.5 mm
1.8 in / 46 mm	Penetration bits across the board	15.5 mm
1.2 in / 64 mm	Wide bit every other space	63 mm

WIDE - 64 mm SERRATION



SHARP - 38 mm SERRATION



WIDE/PENETRATION - 25 mm SERRATION



WIDE - CONTINUOUS EDGE



SNOWBIT - CONTINUOUS EDGE



LINKAGE PINS »

Motor graders clear the way for machines and vehicles in all kinds of conditions. From grading dirt and gravel to snow removal, components take on tough materials. That's why inspection and maintenance are so important. It's no secret that the longer parts last, the stronger your bottom line. That's why regular inspections, maintenance and proper replacement are critically important. You may not see it, but you could be ruining your pins. Poor maintenance can cost machine downtime for services that could have been avoided. Cat® linkage pins and bearings are designed to meet strict standards and are quality tested to ensure more time between replacements, which means less downtime and more savings in the long run.

Front Axle Pins

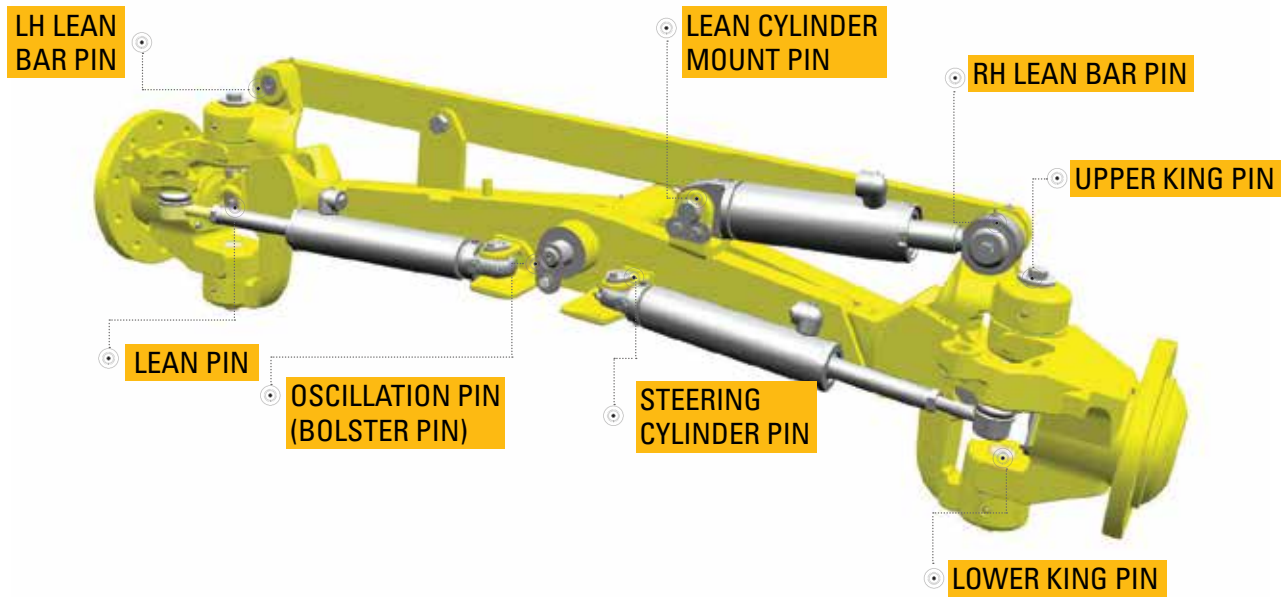

FRONT AXLE PINS																								
SALES MODEL	LH Lean Bar Pin			Lean Cylinder Mount Pin			RH Lean Bar Pin			Upper King Pin			Lower King Pin			Oscillation Pin (Bolster Pin)			Lean Pin		Steering Cylinder Pin			
	QTY	Part Number	Part Description	QTY	Part Number	Part Description	QTY	Part Number	Part Description	QTY	Part Number	Part Description	QTY	Part Number	Part Description	QTY	Part Number	Part Description	QTY	Part Number	Part Description			
14M	1	257-9796	Pin	1	264-9726	Pin	1	257-9795	Pin	2	257-9799	Pin	2	257-9799	Pin	1	257-2291	Pin As	2	258-8739	Pin	2	257-2758	Pin As
	1	2G-8631	Bushing	1	2G-8631	Bushing	2	2G-8631	Bushing (Bar As & Rod End)	2	2G-7387	Bushing	2	2G-7388	Bushing	2	257-2289	Bushing	4	2G-8793	Bearing	2	2D-8652	Bearing
	2	7K-9202	Seal	2	7K-9202	Seal	4	7K-9202	Seal	2	2G-8777	Seal	2	2G-8777	Seal	2	5P-8847	Seal	4	5P-8843	Seal	-	-	-
	1	2G-5667	Retainer	1	6G-7187	Lock	2	2G-5667	Retainer	2	9M-2092	Seal-o-Ring	2	5P-8890	Seal	2	2G-5668	Washer	4	8T-4137	Bolt	2	258-9981	Spacer
	1	198-4768	Washer	2	5P-8245	Washer	2	198-4768	Washer	2	2G-8626	Washer	2	9M-2092	Seal-o-Ring	2	2G-5669	Washer	4	7X-7729	Washer	2	8T-4121	Washer
	1	6V-5844	Bolt	2	6V-3668	Bolt	2	6V-5844	Bolt	2	2G-8741	Ring	2	2G-8741	Ring	1	8T-4139	Bolt	4	259-2622	Washer	2	8T-4137	Bolt
	-	-	-	-	-	-	-	-	-	2	2G-8741	Washer	2	7X-2561	Bolt	1	5P-1076	Washer	-	-	-	-	-	-
	-	-	-	-	-	-	-	-	-	2	7X-2561	Bolt	-	-	-	1	9G-5211	Spacer	-	-	-	-	-	-
14M3	1	257-9796	Pin	1	264-9726	Pin	1	257-9795	Pin	2	257-9799	Pin	2	257-9799	Pin	1	378-3737	Pin As	2	258-8739	Pin	2	391-0217	Pin As
	1	2G-8631	Bushing	1	2G-8631	Bushing	2	2G-8631	Bushing (Bar As & Rod End)	2	2G-7387	Bushing	2	2G-7388	Bushing	2	257-2289	Bushing	4	2G-8793	Bearing	2	2D-8652	Bearing
	2	7K-9202	Seal	2	7K-9202	Seal	4	7K-9202	Seal	2	2G-8777	Seal	2	2G-8777	Seal	2	5P-8847	Seal	4	7K-9203	Seal	-	-	-
	1	2G-5667	Retainer	1	6G-7187	Lock	2	2G-5667	Retainer	2	9M-2092	Seal-o-Ring	2	5P-8890	Seal	2	2G-5668	Washer	4	8T-4137	Bolt	2	8T-4121	Washer
	1	198-4768	Washer	2	5P-8245	Washer	2	198-4768	Washer	2	2G-8626	Washer	2	9M-2092	Seal-o-Ring	2	2G-5669	Washer	4	7X-7729	Washer	2	8T-4196	Bolt
	1	6V-5844	Bolt	2	6V-3668	Bolt	2	6V-5844	Bolt	2	2G-8741	Ring	2	2G-8741	Ring	1	8T-4956	Bolt	4	259-2622	Washer	2	7X-0632	Washer
	-	-	-	-	-	-	-	-	-	2	266-7315	Washer	2	7X-2561	Bolt	1	7X-0618	Washer	-	-	-	2	5T-9400	Spacer
	-	-	-	-	-	-	-	-	-	2	7X-2561	Bolt	-	-	-	1	106-1242	Spacer	-	-	-	2	258-9981	Spacer
14	1	257-9796	Pin	1	264-9726	Pin	1	257-9795	Pin	2	257-9799	Pin	2	257-9799	Pin	1	378-3737	Pin As	2	258-8739	Pin	2	391-0217	Pin As
	1	2G-8631	Bushing	1	2G-8631	Bushing	2	2G-8631	Bushing (Bar As & Rod End)	2	2G-7387	Bushing	2	2G-7388	Bushing	2	257-2289	Bushing	4	2G-8793	Bearing	2	2D-8652	Bearing
	2	7K-9202	Seal	2	7K-9202	Seal	4	7K-9202	Seal	2	2G-8777	Seal	2	2G-8777	Seal	2	5P-8847	Seal	4	7K-9203	Seal	-	-	-
	1	2G-5667	Retainer	1	6G-7187	Lock	2	2G-5667	Retainer	2	9M-2092	Seal-o-Ring	2	5P-8890	Seal	2	2G-5668	Washer	4	8T-4137	Bolt	2	8T-4121	Washer
	1	198-4768	Washer	2	5P-8245	Washer	2	198-4768	Washer	2	2G-8626	Washer	2	9M-2092	Seal-o-Ring	2	2G-5669	Washer	4	7X-7729	Washer	2	8T-4196	Bolt
	1	6V-5844	Bolt	2	6V-3668	Bolt	2	6V-5844	Bolt	2	2G-8741	Ring	2	2G-8741	Ring	1	8T-4956	Bolt	4	259-2622	Washer	2	7X-0632	Washer
	-	-	-	-	-	-	-	-	-	2	266-7315	Washer	2	7X-2561	Bolt	1	7X-0618	Washer	-	-	-	2	5T-9400	Spacer
	-	-	-	-	-	-	-	-	-	2	7X-2561	Bolt	-	-	-	1	106-1242	Spacer	-	-	-	2	258-9981	Spacer

Front Axle Pins Cont'd

FRONT AXLE PINS																								
SALES MODEL	LH Lean Bar Pin			Lean Cylinder Mount Pin			RH Lean Bar Pin			Upper King Pin			Lower King Pin			Oscillation Pin (Bolster Pin)			Lean Pin			Steering Cylinder Pin		
	QTY	Part Number	Part Description	QTY	Part Number	Part Description	QTY	Part Number	Part Description	QTY	Part Number	Part Description	QTY	Part Number	Part Description	QTY	Part Number	Part Description	QTY	Part Number	Part Description	QTY	Part Number	Part Description
16GC	1	264-1152	Pin	1	2G-8611	Pin	1	264-1155	Pin	2	264-1167	Pin	2	257-9799	Pin	1	365-8210	Pin As-Rear	2	264-1168	Pin	2	426-4335	Pin
	1	2G-8635	Bushing	1	2G-8635	Bushing	2	2G-8635	Bushing (Bar As & Rod End)	2	2G-7106	Bushing	2	2G-8738	Bushing	1	365-8211	Pin As-Front	4	8J-5778	Bushing	4	438-1542	Spacer
	2	7K-9203	Seal	2	5P8843	Seal	2	7K-9203	Seal	2	2G-8741	Seal	2	2G-8741	Seal	2	2G-8668	Washer	4	7K-9206	Seal	2	198-4777	Washer
	1	2G-5667	Retainer	1	6G-7187	Lock	2	2G-5667	Retainer	4	2G-8615	Washer	2	5P-8890	Seal	2	2G-5669	Washer	4	4I-5480	Washer	2	7X-0632	Washer
	1	198-4768	Washer	1	5P-8245	Washer	2	198-4768	Washer	2	2G-8626	Washer	2	3B-8489	Adapter	2	287-5718	Washer	4	7X-7729	Washer	2	8T-4121	Washer
	1	6V-5844	Bolt	1	6V-3668	Bolt	2	6V-5844	Bolt	2	266-7315	Washer	2	7X-2561	Bolt	2	8T-4123	Washer	4	8T-4137	Bolt	2	291-5203	Bolt
	-	-	-	-	-	-	-	-	-	2	7X-2561	Bolt	-	-	-	2	8T-6430	Bolt	-	-	-	-	-	-
	-	-	-	-	-	-	-	-	-	-	-	-	-	-	-	2	219-5757	Boss	-	-	-	-	-	-
	-	-	-	-	-	-	-	-	-	-	-	-	-	-	2	3B-8489	Adapter	-	-	-	-	-	-	-
	-	-	-	-	-	-	-	-	-	-	-	-	-	-	-	-	-	-	-	-	-	-	-	-
16M	1	264-1152	Pin	1	2G-8611	Pin	1	264-1155	Pin	2	264-1167	Pin	2	257-9799	Pin	1	110-7721	Pin-Rear	2	264-1168	Pin	2	391-0217	Pin As
	1	2G-8635	Bushing	1	2G-8635	Bushing	2	2G-8635	Bushing (Bar As & Rod End)	2	2G-7106	Bushing	2	2G-8738	Bushing	1	110-7722	Pin-Front	4	8J-5778	Bushing	2	2D-8652	Bearing
	2	7K-9203	Seal	2	5P8843	Seal	2	7K-9203	Seal	2	2G-8777	Seal	2	2G-8777	Seal	4	2G-8607	Bushing	4	7K-9206	Seal	-	-	-
	1	2G-5667	Retainer	1	6G-7187	Lock	2	2G-5667	Retainer	2	9M-2092	Seal-o-Ring	2	5P-8890	Seal	4	5P-8847	Seal	4	4I-5480	Washer	2	258-9981	Spacer
	1	198-4768	Washer	1	5P-8245	Washer	2	198-4768	Washer	2	2G-8626	Washer	2	9M-2092	Seal-o-Ring	2	2G-5668	Washer	4	7X-7729	Washer	2	8T-4121	Washer
	1	6V-5844	Bolt	1	6V-3668	Bolt	2	6V-5844	Bolt	2	2G-8741	Bolt	2	2G-8741	Ring	2	2G-5669	Washer	4	8T-4137	Bolt	2	7X-0632	Washer
	-	-	-	-	-	-	-	-	-	2	266-7315	Washer	2	7X-2561	Bolt	2	250-0492	Bolt	-	-	-	2	5T-9400	Spacer
	-	-	-	-	-	-	-	-	-	2	7X-2561	Bolt	-	-	-	2	6V-7687	Lock Nut	-	-	-	2	6V-5842	Bolt
	-	-	-	-	-	-	-	-	-	4	2G-8615	Washer	-	-	-	-	-	-	-	-	-	-	-	-
	-	-	-	-	-	-	-	-	-	-	-	-	-	-	-	-	-	-	-	-	-	-	-	-
16M3	1	264-1152	Pin	1	2G-8611	Pin	1	264-1155	Pin	2	264-1167	Pin	2	257-9799	Pin	1	365-8211	Pin As-Front	2	264-1168	Pin	2	426-4335	Pin As
	1	2G-8635	Bushing	1	2G-8635	Bushing	2	2G-8635	Bushing (Bar As & Rod End)	2	2G-7106	Bushing	2	2G-8738	Bushing	1	365-8210	Pin As-Rear	4	8J-5778	Bushing	2	4D-0298	Bearing
	2	7K-9203	Seal	2	5P8843	Seal	2	7K-9203	Seal	2	2G-8777	Seal	2	2G-8777	Seal	4	2G-8607	Bushing	4	7K-9206	Seal	-	-	-
	1	2G-5667	Retainer	1	6G-7187	Lock	2	2G-5667	Retainer	2	9M-2092	Seal-o-Ring	2	5P-8890	Seal	4	5P-8847	Seal	4	4I-5480	Washer	6	438-1542	Spacer
	1	198-4768	Washer	1	5P-8245	Washer	2	198-4768	Washer	2	2G-8626	Washer	2	9M-2092	Seal-o-Ring	2	2G-5668	Washer	4	7X-7729	Washer	2	124-6524	Spacer
	1	6V-5844	Bolt	1	6V-3668	Bolt	2	6V-5844	Bolt	2	2G-8741	Bolt	2	2G-8741	Ring	2	2G-5669	Washer	4	8T-4137	Bolt	2	6V-5842	Bolt
	-	-	-	-	-	-	-	-	-	2	266-7315	Washer	2	7X-2561	Bolt	2	287-5718	Washer	-	-	-	2	7X-0632	Washer
	-	-	-	-	-	-	-	-	-	2	7X-2561	Bolt	-	-	-	2	8T-4123	Washer	-	-	-	2	8T-4121	Washer
	-	-	-	-	-	-	-	-	-	4	2G-8615	Washer	-	-	-	2	8T-6430	Bolt	-	-	-	-	-	-
	-	-	-	-	-	-	-	-	-	-	-	-	-	-	-	-	-	-	-	-	-	-	-	-
16	1	264-1152	Pin	1	2G-8611	Pin	1	264-1155	Pin	2	264-1167	Pin	2	257-9799	Pin	1	365-8211	Pin As-Front	2	264-1168	Pin	2	426-4335	Pin As
	1	2G-8635	Bushing	1	2G-8635	Bushing	2	2G-8635	Bushing (Bar As & Rod End)	2	2G-7106	Bushing	2	2G-8738	Bushing	1	365-8210	Pin As-Rear	4	8J-5778	Bushing	2	4D-0298	Bearing
	2	7K-9203	Seal	2	5P8843	Seal	2	7K-9203	Seal	2	2G-8777	Seal	2	2G-8777	Seal	4	2G-8607	Bushing	4	7K-9206	Seal	-	-	-
	1	2G-5667	Retainer	1	6G-7187	Lock	2	2G-5667	Retainer	2	9M-2092	Seal-o-Ring	2	5P-8890	Seal	4	5P-8847	Seal	4	4I-5480	Washer	6	438-1542	Spacer
	1	198-4768	Washer	1	5P-8245	Washer	2	198-4768	Washer	2	2G-8626	Washer	2	9M-2092	Seal-o-Ring	2	2G-5668	Washer	4	7X-7729	Washer	2	124-6524	Spacer
	1	6V-5844	Bolt	1	6V-3668	Bolt	2	6V-5844	Bolt	2	2G-8741	Bolt	2	2G-8741	Ring	2	2G-5669	Washer	4	8T-4137	Bolt	2	6V-5842	Bolt
	-	-	-	-	-	-	-	-	-	2	266-7315	Washer	2	7X-2561	Bolt	2	287-5718	Washer	-	-	-	2	7X-0632	Washer
	-	-	-	-	-	-	-	-	-	2	7X-2561	Bolt	-	-	-	2	8T-4123	Washer	-	-	-	2	8T-4121	Washer
	-	-	-	-	-	-	-	-	-	4	2G-8615	Washer	-	-	-	2	8T-6430	Bolt	-	-	-	-	-	-
	-	-	-	-	-	-	-	-	-	-	-	-	-	-	-	-	-	-	-	-	-	-	-	-
18M3	1	264-1152	Pin	1	2G-8611	Pin	1	264-1155	Pin	2	264-1167	Pin	2	257-9799	Pin	1	365-8211	Pin As-Front	2	264-1168	Pin	2	426-4335	Pin As
	1	2G-8635	Bushing	1	2G-8635	Bushing	2	2G-8635	Bushing (Bar As & Rod End)	2	2G-7106	Bushing	2	2G-8738	Bushing	1	365-8210	Pin As-Rear	4	8J-5778	Bushing	2	4D-0298	Bearing
	2	7K-9203	Seal	2	5P8843	Seal	2	7K-9203	Seal	2	2G-8777	Seal	2	2G-8777	Seal	4	2G-8607	Bushing	4	7K-9206	Seal	-	-	-
	1	2G-5667	Retainer	1	6G-7187	Lock	2	2G-5667	Retainer	2	9M-2092	Seal-o-Ring	2	5P-8890	Seal	4	5P-8847	Seal	4	4I-5480	Washer	6	438-1542	Spacer
	1	198-4768	Washer	1	5P-8245	Washer	2	198-4768	Washer	2	2G-8626	Washer	2	9M-2092	Seal-o-Ring	2	2G-5668	Washer	4	7X-7729	Washer	2	124-6524	Spacer
	1	6V-5844	Bolt	1	6V-3668	Bolt	2	6V-5844	Bolt	2	2G-8741	Bolt	2	2G-8741	Ring	2	2G-5669	Washer	4	8T-4137	Bolt	2	6V-5842	Bolt
	-	-	-	-	-	-	-	-	-	2	266-7315	Washer	2	7X-2561	Bolt	2	287-5718	Washer	-	-	-	2	7X-0632	Washer
	-	-	-	-	-	-	-	-	-	2	7X-2561	Bolt	-	-	-	2	8T-4123	Washer	-	-	-	2	8T-4121	Washer
	-	-	-	-	-	-	-	-	-	4	2G-8615	Washer	-	-	-	2	8T-6430	Bolt	-	-	-	-	-	-
	-	-	-	-	-	-	-	-	-	-	-	-	-	-	-	-	-	-	-	-	-	-	-	-
18	1	264-1152	Pin	1	2G-8611	Pin	1	264-1155	Pin	2	264-1167	Pin	2	257-9799	Pin	1	365-8211	Pin As-Front	2	264-1168	Pin	2	426-4335	Pin As
	1	2G-8635	Bushing	1	2G-8635	Bushing	2	2G-8635	Bushing (Bar As & Rod End)	2	2G-7106	Bushing	2	2G-8738	Bushing	1	365-8210	Pin As-Rear	4	8J-5778	Bushing	2	4D-0298	Bearing
	2	7K-9203	Seal	2	5P8843	Seal	2	7K-9203	Seal	2	2G-8777	Seal	2	2G-8777	Seal	4	2G-8607	Bushing	4	7K-9206	Seal	-	-	-
	1	2G-5667	Retainer	1	6G-7187	Lock	2	2G-5667	Retainer	2	9M-2092	Seal-o-Ring	2	5P-8890	Seal	4	5P-8847	Seal	4	4I-5480	Washer	6	438-1542	Spacer
	1	198-4768	Washer	1	5P-8245	Washer	2	198-4768	Washer	2	2G-8626	Washer	2	9M-2092	Seal-o-Ring	2	2G-5668	Washer	4	7X-7729	Washer	2	124-6524	Spacer
	1	6V-5844	Bolt	1	6V-3668	Bolt	2	6V-5844	Bolt	2	2G-8741	Bolt	2	2G-8741	Ring	2	2G-5669	Washer	4	8T-4137	Bolt	2	6V-5842	Bolt
	-	-	-	-	-	-	-	-	-	2	266-7315	Washer	2	7X-2561	Bolt	2	287-5718	Washer	-	-	-	2	7X-0632	

Circle Pins

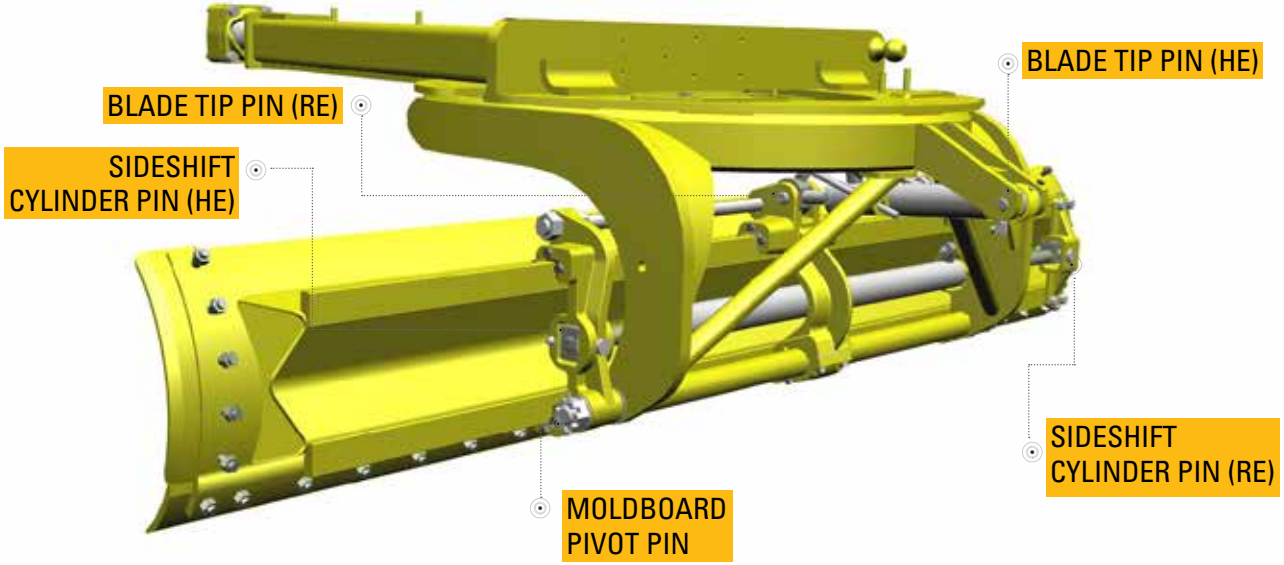

PINES CIRCULARES																		
SALES MODEL	Blade Tip Pin (HE)			Blade Tip Pin (RE)			Sideshift Cylinder Pin (RE)			Sideshift Cylinder Pin (HE)			Moldboard Pivot Pin			Lubricated Moldboard Pivot Pin		
	QTY	Part Number	Part Description	QTY	Part Number	Part Description	QTY	Part Number	Part Description	QTY	Part Number	Part Description	QTY	Part Number	Part Description	QTY	Part Number	Part Description
14M	1	364-1374	Pin As	1	364-1374	Pin As	1	1H-4478	Pin	1	312-6156	Pin	2	6G-4831	Shaft	-	-	-
	1	170-3093	Bushing	1	170-3093	Bushing	1	3B-4647	Cotter	1	3B-4647	Cotter	4	8W-4167	Bushing	-	-	-
	1	4D-0298	Bearing	1	4D-0298	Bearing	-	-	-	2	9R-0109	Washer	4	4J-1888	Cotter	-	-	-
	2	248-9337	Spacer	1	7X-0618	Washer	-	-	-	-	-	-	4	5F-3715	Nut	-	-	-
	1	7X-0618	Washer	1	8T-4183	Bolt	-	-	-	-	-	-	8	7Y-0725	Washer	-	-	-
	1	8T-4183	Bolt	-	-	-	-	-	-	-	-	-	-	-	-	-	-	-
14M3	1	364-1374	Pin As	1	364-1374	Pin As	1	1H-4478	Pin	1	312-6156	Pin	-	-	-	2	567-7552	Pin
	1	170-3093	Bushing	1	170-3093	Bushing	1	3B-4647	Cotter	1	3B-4647	Cotter	-	-	-	4	8W-4167	Bushing
	1	4D-0298	Bearing	1	4D-0298	Bearing	-	-	-	2	9R-0109	Washer	-	-	-	26	253-4643	Shim
	2	248-9337	Spacer	1	7X-0618	Washer	-	-	-	-	-	-	-	-	-	2	567-7553	Collar
	1	7X-0618	Washer	1	8T-4183	Bolt	-	-	-	-	-	-	-	-	-	2	8T-4173	Bolt
	1	8T-4183	Bolt	-	-	-	-	-	-	-	-	-	-	-	-	-	-	-
14	1	364-1374	Pin As	1	364-1374	Pin As	1	1H-4478	Pin	1	312-6156	Pin	-	-	-	2	567-7552	Pin
	1	170-3093	Bushing	1	170-3093	Bushing	1	3B-4647	Cotter	1	3B-4647	Cotter	-	-	-	4	8W-4167	Bushing
	1	4D-0298	Bearing	1	4D-0298	Bearing	-	-	-	2	9R-0109	Washer	-	-	-	26	253-4643	Shim
	2	248-9337	Spacer	1	7X-0618	Washer	-	-	-	-	-	-	-	-	-	2	567-7553	Collar
	1	7X-0618	Washer	1	8T-4183	Bolt	-	-	-	-	-	-	-	-	-	2	8T-4173	Bolt
	1	8T-4183	Bolt	-	-	-	-	-	-	-	-	-	-	-	-	-	-	-
16GC	1	364-1374	Pin As	1	364-1374	Pin As	1	1H-4478	Pin	1	312-6156	Pin	-	-	-	2	567-755	Pin
	1	170-3093	Bushing	1	170-3093	Bushing	1	3B-4647	Cotter	1	3B-4647	Cotter	-	-	-	8	8W-4167	Bushing
	2	248-9337	Spacer	1	3B-8485	Bearing	-	-	-	2	9R-0109	Washer	-	-	-	22	253-4643	Shim
	1	3B-8485	Elbow	1	7X-0618	Washer	-	-	-	-	-	-	-	-	-	4	7X-0515	Washer
	1	7X-0618	Washer	1	8T-4183	Bolt	-	-	-	-	-	-	-	-	-	2	3B-8489	Adapter
	1	8T-4183	Bolt	-	-	-	-	-	-	-	-	-	-	-	-	2	8T-4778	Locknut
16M	1	364-1374	Pin As	1	364-1374	Pin As	1	1H-4478	Pin	1	312-6156	Pin	2	6G-4831	Shaft	-	-	-
	1	170-3093	Bushing	1	170-3093	Bushing	1	3B-4647	Cotter	1	3B-4647	Cotter	4	8W-4167	Bushing	-	-	-
	1	4D-0298	Bearing	1	4D-0298	Bearing	-	-	-	2	9R-0109	Washer	4	4J-1888	Cotter	-	-	-
	2	248-9337	Spacer	1	7X-0618	Washer	-	-	-	-	-	-	4	5F-3715	Nut	-	-	-
	1	7X-0618	Washer	1	8T-4183	Bolt	-	-	-	-	-	-	8	7Y-0725	Washer	-	-	-
	1	8T-4183	Bolt	-	-	-	-	-	-	-	-	-	-	-	-	-	-	-
16M3	1	364-1374	Pin As	1	364-1374	Pin As	1	1H-4478	Pin	1	312-6156	Pin	-	-	-	2	567-7552	Pin
	1	170-3093	Bushing	1	170-3093	Bushing	1	3B-4647	Cotter	1	3B-4647	Cotter	-	-	-	4	8W-4167	Bushing
	1	4D-0298	Bearing	1	4D-0298	Bearing	-	-	-	2	9R-0109	Washer	-	-	-	26	253-4643	Shim
	2	248-9337	Spacer	1	7X-0618	Washer	-	-	-	-	-	-	-	-	-	2	567-7553	Collar
	1	7X-0618	Washer	1	8T-4183	Bolt	-	-	-	-	-	-	-	-	-	2	8T-4173	Bolt
	1	8T-4183	Bolt	-	-	-	-	-	-	-	-	-	-	-	-	-	-	-
16	1	364-1374	Pin As	1	364-1374	Pin As	1	1H-4478	Pin	1	312-6156	Pin	-	-	-	2	567-7552	Pin
	1	170-3093	Bushing	1	170-3093	Bushing	1	3B-4647	Cotter	1	3B-4647	Cotter	-	-	-	4	8W-4167	Bushing
	1	4D-0298	Bearing	1	4D-0298	Bearing	-	-	-	2	9R-0109	Washer	-	-	-	26	253-4643	Shim
	2	248-9337	Spacer	1	7X-0618	Washer	-	-	-	-	-	-	-	-	-	2	567-7553	Collar
	1	7X-0618	Washer	1	8T-4183	Bolt	-	-	-	-	-	-	-	-	-	2	8T-4173	Bolt
	1	8T-4183	Bolt	-	-	-	-	-	-	-	-	-	-	-	-	-	-	-
18M3	1	364-1374	Pin As	1	364-1374	Pin As	1	1H-4478	Pin	1	312-6156	Pin	-	-	-	2	567-7552	Pin
	1	170-3093	Bushing	1	170-3093	Bushing	1	3B-4647	Cotter	1	3B-4647	Cotter	-	-	-	4	8W-4167	Bushing
	1	4D-0298	Bearing	1	4D-0298	Bearing	-	-	-	2	9R-0109	Washer	-	-	-	26	253-4643	Shim
	2	248-9337	Spacer	1	7X-0618	Washer	-	-	-	-	-	-	-	-	-	2	567-7553	Collar
	1	7X-0618	Washer	1	8T-4183	Bolt	-	-	-	-	-	-	-	-	-	2	8T-4173	Bolt
	1	8T-4183	Bolt	-	-	-	-	-	-	-	-	-	-	-	-	-	-	-
18	1	364-1374	Pin As	1	364-1374	Pin As	1	1H-4478	Pin	1	312-6156	Pin	-	-	-	2	567-7552	Pin
	1	170-3093	Bushing	1	170-3093	Bushing	-	-	-	2	9R-0109	Washer	-	-	-	4	8W-4167	Bushing
	1	4D-0298	Bearing	1	4D-0298	Bearing	-	-	-	-	-	-	-	-	-	26	253-4643	Shim
	2	248-9337	Spacer	1	7X-0618	Washer	-	-	-	-	-	-	-	-	-	2	567-7553	Collar
	1	7X-0618	Washer	1	8T-4183	Bolt	-	-	-	-	-	-	-	-	-	2	8T-4173	Bolt
	1	8T-4183	Bolt	-	-	-	-	-	-	-	-	-	-	-	-	-	-	-
24M	2	194-6555	Pin As	2	5G-8574	Pin As	1	138-7426	Pin	1	8G-0876	Pin As	-	-	-	2	194-3857	Pin
	2	118-2289	Bushing	2	118-2289	Bushing	1	5J-1446	Bearing	1	7X-0515	Washer	-	-	-	2	087-5379	Bearing
	2	9V-4924	Spacer	2	9V-4924	Spacer	1	117-2190	Plate-Retainer	1	7X-2553	Bolt	-	-	-	4	9X-4597	Seal
	2	7X-0590	Washer	2	7X-0590	Washer	2	8T-4192	Bolt	1	8S-1069	Washer	-	-	-	1	7X-0515	Washer
	2	8T-4956	Bolt	2	8T-4956	Bolt	2	8T-4223	Washer	-	-	-	-	-	-	1	7X-2553	Bolt
	-	-	-	-	-	-	-	-	-	-	-	-	-	-	-	1	8S-1069	Washer
24	2	194-6555	Pin As	2	5G-8574	Pin As	1	138-7426	Pin	1	8G-0876	Pin As	-	-	-	2	470-0337	Pin
	2	118-2289	Bushing	2	118-2289	Bushing	1	5J-1446	Bearing	1	7X-0515	Washer	-	-	-	2	474-9320	Bearing
	2	10-3833	Spacer	2	9V-4924	Spacer	1	117-2190	Plate-Retainer	1	7X-2553	Bolt	-	-	-	4	9X-4598	Seal
	2	7X-0590	Washer	2	7X-0590	Washer	2	8T-4192	Bolt	1	8S-1069	Washer	-	-	-	4	140-8448	Plate
	2	8T-4956	Bolt	2	8T-4956	Bolt	2	8T-4223	Washer	-	-	-	-	-	-	2	138-7435	Spacer
	-	-	-	-	-	-	-	-	-	-	-	-	-	-	-	2	138-7436	Shim
-	-	-	-	-	-	-	-	-	-	-	-	-	-	-	16	8T-4140	Bolt	
-	-	-	-	-	-	-	-	-	-	-	-	-	-	-	16	198-4780	Washer	

Articulation Pins

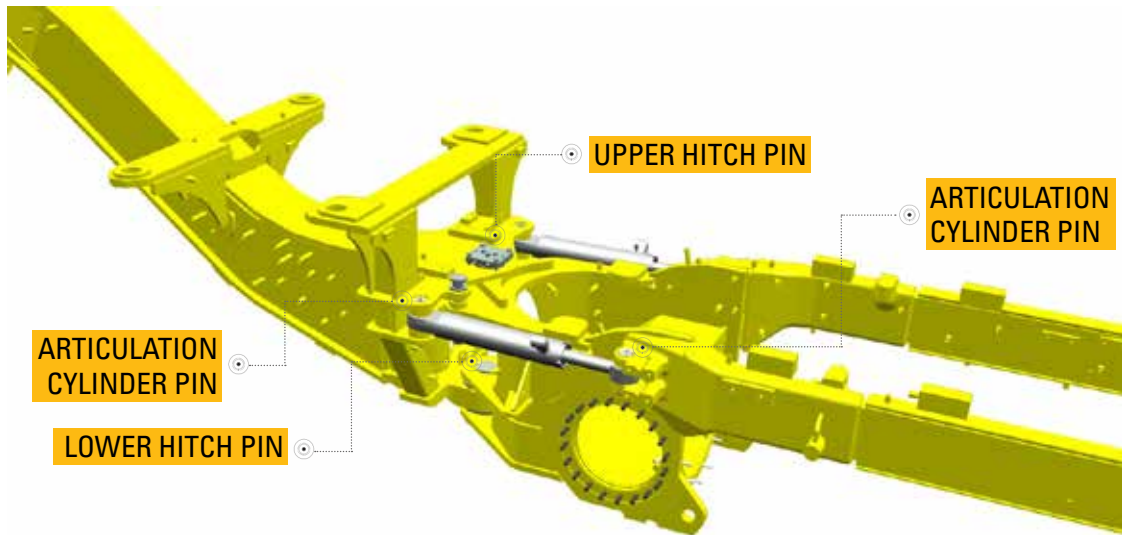

ARTICULATION PINS												
SALES MODEL	Upper Hitch Pin			Lower Hitch Pin			Articulation Cylinder Pins (HE)			Articulation Cylinder Pins (RE)		
	QTY	Part Number	Part Description	QTY	Part Number	Part Description	QTY	Part Number	Part Description	QTY	Part Number	Part Description
14M	1	252-1824	Pin	1	252-0980	Pin	2	388-9436	Pin As	2	388-9435	Pin As
	1	4K-8734	Bearing	1	4K-7467	Bearing As-Roller	2	8X-5021	Bearing	2	8D-7685	Bearing
	1	252-0990	Bushing	1	4K-7461	Seal	4	7K-9203	Seal	4	7K-9203	Seal
	2	4K-7463	Seal	1	4K-7462	Seal	8	2K-4160	Washer	8	2K-4160	Washer
	2	319-6699	Bolt	4	8T-4140	Bolt	2	3B-5316	Pin-Cotter	2	3B-5316	Pin-Cotter
	2	8T-4223	Washer	4	9X-8257	Washer	2	5P-1076	Washer	2	5P-1076	Washer
	1	2V-4332	Collar	1	252-0989	Spacer	2	8T-4956	Bolt	2	8T-4956	Bolt
	1	259-9283	Cover	4	4K-6781	Spacer	2	170-3093	Bushing	2	170-3093	Bushing
	4	8T-4223	Washer	4	4K-7464	Shim	-	-	-	-	-	-
	4	288-0735	Bolt	6	096-9986	Bolt	-	-	-	-	-	-
	-	-	-	6	8T-4223	Washer	-	-	-	-	-	-
	-	-	-	4	4K-7465	Shim	-	-	-	-	-	-
	-	-	-	1	373-2437	Plate As	-	-	-	-	-	-
	14M3	1	481-3159	Pin	1	370-3220	Pin As	2	384-4456	Pin	2	504-8259
1		4K-7467	Bearing As-Roller	2	582-9201	Bearing	2	500-2893	Bearing	2	500-2892	Bearing
2		4K-7463	Seal	1	252-0990	Bushing	4	7K-9203	Seal	4	7K-9203	Seal
4		8T-4194	Bolt	2	4K-7463	Seal	2	6G-7187	Lock	8	506-6677	Shim
4		8T-4184	Bolt	2	8T-4121	Washer	18	506-6677	Shim	2	3B-5317	Cotter
8		8T-4223	Washer	2	8T-4195	Bolt	4	039-8557	Washer	2	1S-4305	Spacer
1		370-3214	Shim	1	389-9730	Retainer Plate	4	8T-4139	Bolt	2	7X-0590	Washer
1		370-3215	Shim	-	-	-	-	-	-	2	8T-4183	Bolt
1		370-3217	Spacer	-	-	-	-	-	-	-	-	-
10		8T-4194	Bolt	-	-	-	-	-	-	-	-	-
10		8T-4223	Washer	-	-	-	-	-	-	-	-	-
1		370-3216	Plate	-	-	-	-	-	-	-	-	-
1		370-3213	Plate	-	-	-	-	-	-	-	-	-
14		1	481-3159	Pin	1	370-3220	Pin As	2	384-4456	Pin	2	504-8259
	1	4K-7467	Bearing As-Roller	2	582-9201	Bearing	2	500-2893	Bearing	2	500-2892	Bearing
	2	4K-7463	Seal	1	252-0990	Bushing	4	7K-9203	Seal	4	7K-9203	Seal
	4	8T-4194	Bolt	2	4K-7463	Seal	2	6G-7187	Lock	8	506-6677	Shim
	4	8T-4184	Bolt	2	8T-4121	Washer	18	506-6677	Shim	2	3B-5317	Cotter
	8	8T-4223	Washer	2	8T-4195	Bolt	4	039-8557	Washer	2	1S-4305	Spacer
	1	370-3214	Shim	1	389-9730	Retainer Plate	4	8T-4139	Bolt	2	7X-0590	Washer
	1	370-3215	Shim	-	-	-	-	-	-	2	8T-4183	Bolt
	1	370-3217	Spacer	-	-	-	-	-	-	-	-	-
	10	8T-4194	Bolt	-	-	-	-	-	-	-	-	-
	10	8T-4223	Washer	-	-	-	-	-	-	-	-	-
	1	370-3216	Plate	-	-	-	-	-	-	-	-	-
	1	370-3213	Plate	-	-	-	-	-	-	-	-	-
	16GC	1	589-3762	Pin As	1	626-8087	Pin	2	629-8620	Pin	2	585-4223
1		5K-3496	Bushing	1	627-1659	Washer	4	7K-9204	Seal	2	1S-4305	Spacer
2		1J-2150	Seal	1	5K-3496	Bushing	4	039-8557	Washer	2	7X-0590	Washer
1		122-4026	Spacer	1	1J-2150	Seal	7	506-6677	Shim	2	8T-4183	Bolt
1		7X-0590	Washer	1	166-1498	Seal	4	8T-4139	Bolt	7	506-6677	Shim
1		8T-4194	Bolt	1	627-1163	Boss	2	8T-4139	Plate	-	-	-
-		-	-	1	111-7077	Disc-Thrust	-	-	-	-	-	-
-		-	-	1	627-1656	Spacer	-	-	-	-	-	-
-		-	-	1	630-5469	Ring	-	-	-	-	-	-
-		-	-	4	479-2171	Bolt As	-	-	-	-	-	-
-		-	-	1	627-1660	Cover	-	-	-	-	-	-
-		-	-	1	5P-5072	Ring-Retaining	-	-	-	-	-	-

Articulation Pins Con't

ARTICULATION PINS												
SALES MODEL	Upper Hitch Pin			Lower Hitch Pin			Articulation Cylinder Pins (HE)			Articulation Cylinder Pins (RE)		
	QTY	Part Number	Part Description	QTY	Part Number	Part Description	QTY	Part Number	Part Description	QTY	Part Number	Part Description
16M	1	419-0985	Pin As	1	276-2633	Pin	2	277-8758	Pin As	1	316-6136	Pin As (LH)
	1	5K-3494	Bushing	1	5K-3929	Bearing As	2	277-5435	Bearing	1	316-6137	Pin As (RH)
	1	5K-3496	Bushing	2	3K-6454	Seal	4	9D-6584	Seal	2	3G-2582	Bearing
	2	1J-2150	Seal	1	5K-3490	Spacer	8	1K-7081	Washer	8	1K-7081	Washer
	4	141-8390	Bolt	1	5K-3491	Spacer	2	5P-1076	Washer	2	3B-5317	Pin-Cotter
	4	9X-8257	Washer	1	5K-3489	Shim	2	8T-4139	Bolt	2	7X-0515	Washer
	1	5K-3495	Collar	4	8T-4140	Bolt	2	170-3093	Bushing	2	7X-2553	Bolt
	-	-	-	4	9X-8257	Washer	-	-	-	2	4T-3658	Tube
	-	-	-	1	373-2439	Plate As	-	-	-	4	7K-9204	Seal
	-	-	-	8	96-9986	Bolt	-	-	-	-	-	-
	-	-	-	8	8T-4223	Washer	-	-	-	-	-	-
	16M3	1	483-3845	Pin	1	472-0422	Pin As	2	509-7379	Pin As	2	386-7411
1		5K-3929	Bearing As-Roller	2	5K-3494	Bushing	2	391-4387	Bushing	2	8D-8168	Bearing
2		3K-6454	Seal	1	5K-3496	Bushing	4	3P-1461	Seal	4	7K-9205	Seal
8		8T-4193	Bolt	2	3E-6757	Seal	2	267-8821	Washer	2	151-5520	Washer
8		9X-8257	Washer	2	8T-4121	Washer	2	3V-9244	Washer	2	267-8821	Washer
1		370-3209	Shim	2	8T-4195	Bolt	2	8T-7338	Bolt	2	3B-5317	Cotter
1		370-3208	Shim	1	389-9730	Retainer Plate	16	9R-8390	Spacer	2	8T-4140	Bolt
1		370-3226	Spacer	-	-	-	2	9X-8257	Washer	34	9R-8291	Spacer
1		370-3225	Plate	-	-	-	-	-	-	2	9X-8257	Washer
1		370-3207	Plate	-	-	-	-	-	-	-	-	
10		8T-4184	Bolt	-	-	-	-	-	-	-	-	
10		8T-4223	Washer	-	-	-	-	-	-	-	-	
16	1	483-3845	Pin	1	472-0422	Pin As	2	509-7379	Pin As	2	386-7411	Pin As
	1	5K-3929	Bearing As-Roller	2	5K-3494	Bushing	2	391-4387	Bushing	2	8D-8168	Bearing
	2	3K-6454	Seal	1	5K-3496	Bushing	4	3P-1461	Seal	4	7K-9205	Seal
	8	8T-4193	Bolt	2	3E-6757	Seal	2	267-8821	Washer	2	151-5520	Washer
	8	9X-8257	Washer	2	8T-4121	Washer	2	3V-9244	Washer	2	267-8821	Washer
	1	370-3209	Shim	2	8T-4195	Bolt	2	8T-7338	Bolt	2	3B-5317	Cotter
	1	370-3208	Shim	1	389-9730	Retainer Plate	16	9R-8390	Spacer	2	8T-4140	Bolt
	1	370-3226	Spacer	-	-	-	2	9X-8257	Washer	34	9R-8291	Spacer
	1	370-3225	Plate	-	-	-	-	-	-	2	9X-8257	Washer
	1	370-3207	Plate	-	-	-	-	-	-	-	-	
	10	8T-4184	Bolt	-	-	-	-	-	-	-	-	
	10	8T-4223	Washer	-	-	-	-	-	-	-	-	
16M3	1	483-3845	Pin	1	472-0422	Pin As	2	509-7379	Pin As	2	386-7411	Pin As
	1	5K-3929	Bearing As-Roller	2	5K-3494	Bushing	2	391-4387	Bushing	2	8D-8168	Bearing
	2	3K-6454	Seal	1	5K-3496	Bushing	4	3P-1461	Seal	4	7K-9205	Seal
	8	8T-4193	Bolt	2	3E-6757	Seal	2	267-8821	Washer	2	151-5520	Washer
	8	9X-8257	Washer	2	8T-4121	Washer	2	3V-9244	Washer	2	267-8821	Washer
	1	370-3209	Shim	2	8T-4195	Bolt	2	8T-7338	Bolt	2	3B-5317	Cotter
	1	370-3208	Shim	1	389-9730	Retainer Plate	16	9R-8390	Spacer	2	8T-4140	Bolt
	1	370-3226	Spacer	-	-	-	2	9X-8257	Washer	34	9R-8291	Spacer
	1	370-3225	Plate	-	-	-	-	-	-	2	9X-8257	Washer
	1	370-3207	Plate	-	-	-	-	-	-	-	-	
	10	8T-4184	Bolt	-	-	-	-	-	-	-	-	
	10	8T-4223	Washer	-	-	-	-	-	-	-	-	
18	1	483-3845	Pin	1	472-0422	Pin As	2	509-7379	Pin As	2	386-7411	Pin As
	1	5K-3929	Bearing As-Roller	2	5K-3494	Bushing	2	391-4387	Bushing	2	8D-8168	Bearing
	2	3K-6454	Seal	1	5K-3496	Bushing	4	3P-1461	Seal	4	7K-9205	Seal
	8	8T-4193	Bolt	2	3E-6757	Seal	2	267-8821	Washer	2	151-5520	Washer
	8	9X-8257	Washer	2	8T-4121	Washer	2	3V-9244	Washer	2	267-8821	Washer
	1	370-3209	Shim	2	8T-4195	Bolt	2	8T-7338	Bolt	2	3B-5317	Cotter
	1	370-3208	Shim	1	389-9730	Retainer Plate	16	9R-8390	Spacer	2	8T-4140	Bolt
	1	370-3226	Spacer	-	-	-	2	9X-8257	Washer	34	9R-8291	Spacer
	1	370-3225	Plate	-	-	-	-	-	-	2	9X-8257	Washer
	1	370-3207	Plate	-	-	-	-	-	-	-	-	
	10	8T-4184	Bolt	-	-	-	-	-	-	-	-	
	10	8T-4223	Washer	-	-	-	-	-	-	-	-	
24M	1	488-2148	Pin	1	488-2153	Pin As	2	360-2870	Pin As	2	360-2870	Pin As
	1	486-1264	Bearing	1	494-0536	Bearing	2	3G-2791	Bushing	2	3G-2791	Bushing
	1	5P-2673	Seal	1	166-1497	Seal	4	7K-9205	Seal	4	7K-9205	Seal
	1	9X-7699	Seal	1	7K-9212	Seal	6	5V-0353	Washer	6	5V-0353	Washer
	1	117-2026	Shim	4	8T-4193	Bolt	4	5V-0354	Washer	4	5V-0354	Washer
	8	7X-2563	Bolt	4	9X-8257	Washer	2	7X-0590	Washer	2	7X-0590	Washer
	8	8T-4123	Washer	4	8G-5258	Spacer	2	8T-4183	Bolt	2	8T-4183	Bolt
	1	488-2152	Spacer	1	178-9481	Plate As.	2	9V-4924	Spacer	2	9V-4924	Spacer
	1	117-2022	Plate	4	7X-0583	Washer	-	-	-	-	-	
	1	117-2024	Plate	4	8T-4140	Bolt	-	-	-	-	-	
	8	8T-4140	Bolt	-	-	-	-	-	-	-	-	
	8	9X-8257	Washer	-	-	-	-	-	-	-	-	
24	1	510-9294	Pin	1	510-9295	Pin	2	360-2870	Pin As	2	360-2870	Pin As
	1	486-1264	Bearing	1	486-1264	Bearing	2	3G-2791	Bushing	2	3G-2791	Bushing
	1	9X-4601	Seal	2	166-1498	Seal	4	7K-9205	Seal	4	7K-9205	Seal
	1	9X-7700	Seal	1	514-5361	Ring Retaining	6	5V-0353	Washer	6	5V-0353	Washer
	1	117-2026	Shim	1	514-5362	Ring Retaining	4	5V-0354	Washer	4	5V-0354	Washer
	1	510-9297	Ring	-	-	-	2	7X-0590	Washer	2	7X-0590	Washer
	4	106-4175	Bolt	-	-	-	2	8T-4183	Bolt	2	8T-4183	Bolt
	4	8T-4123	Washer	-	-	-	2	9V-4924	Spacer	2	9V-4924	Spacer
	1	149-9433	Spacer	-	-	-	-	-	-	-	-	
	1	117-2024	Plate	-	-	-	-	-	-	-	-	
	2	510-9296	Plate	-	-	-	-	-	-	-	-	
	8	8T-4140	Bolt	-	-	-	-	-	-	-	-	
8	9X-8257	Washer	-	-	-	-	-	-	-	-		

Ripper Pins

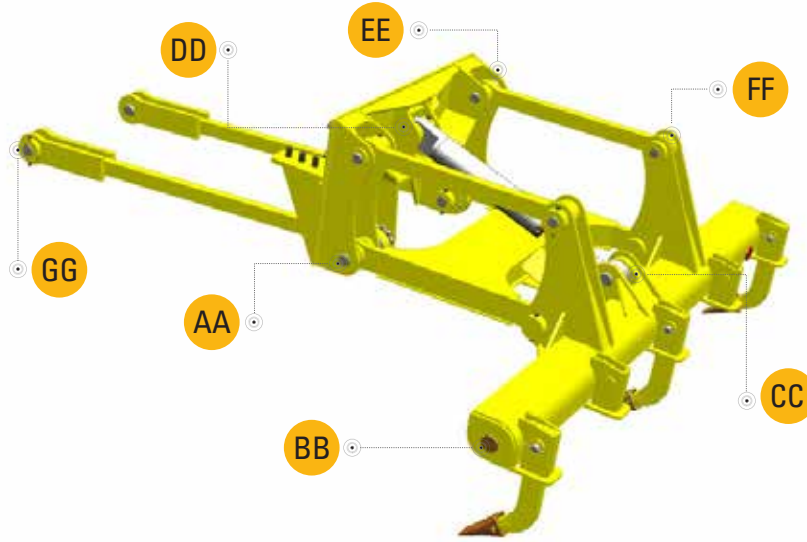

RIPPER PINS																					
SALES MODEL	AA			BB			CC			DD			EE			FF			GG		
	QTY	Part Number	Part Description	QTY	Part Number	Part Description	QTY	Part Number	Part Description	QTY	Part Number	Part Description	QTY	Part Number	Part Description	QTY	Part Number	Part Description	QTY	Part Number	Part Description
14M	2	8J-9092	Pin	2	8J-9607	Pin	1	3K-8510	Pin	-	-	-	2	8J-9608	Pin	2	8J-9608	Pin	2	6K-0715	Pin
	2	3G-2580	Bearing	2	3G-2580	Bearing	1	2K-4507	Bushing	2	4K-3004	Bearing-Trunnion	2	3G-2582	Bearing	2	3G-2582	Bearing	-	-	-
	4	9D-6585	Seal	4	9D-6585	Seal	-	-	-	2	4K-3128	Bushing	4	9D-6584	Seal	4	9D-6584	Seal	-	-	-
	2	8T-4778	Lock Nut	2	8T-4778	Lock Nut	1	2K-0703	Bar	8	6V-7687	Lock Nut	2	7X-2557	Bolt	2	7X-0358	Bolt	2	1K-6872	Lock Nut
14M3	2	7X-2558	Bolt	2	8T-6385	Bolt	2	8T-4139	Bolt	8	8T-4910	Bolt	2	8T-4778	Lock Nut	2	3K-2889	Lock Nut	2	7X-0338	Bolt
	2	8J-9092	Pin	2	8J-9607	Pin	1	3K-8510	Pin	-	-	-	2	8J-9608	Pin	2	8J-9608	Pin	2	6K-0715	Pin
	2	3G-2580	Bearing	2	350-9370	Bearing	1	2K-4507	Bushing	2	4K-3004	Bearing-Trunnion	2	3G-2582	Bearing	2	3G-2582	Bearing	-	-	-
	4	7K-9205	Seal	4	7K-9205	Seal	-	-	-	2	4K-3128	Bushing	4	7K-9204	Seal	4	7K-9204	Seal	-	-	-
14	2	8T-4778	Lock Nut	2	8T-4778	Lock Nut	1	2K-0703	Bar	8	6V-7687	Lock Nut	2	7X-2557	Bolt	2	7X-2557	Bolt	2	129-3180	Lock Nut
	2	7X-2558	Bolt	2	8T-6385	Bolt	2	8T-4192	Bolt	8	8T-4910	Bolt	2	8T-4778	Lock Nut	2	8T-4778	Lock Nut	2	8T-5092	Bolt
	6	9N-4449	Spacer	6	9N-4449	Spacer	-	-	-	-	-	-	-	-	-	-	-	-	-	-	-
	9	9N-4450	Spacer	4	9N-4450	Spacer	1	3K-8510	Pin	-	-	-	-	-	-	-	-	-	-	-	-
16GC	2	8J-9092	Pin	2	8J-9607	Pin	1	2K-4507	Bushing	-	-	-	2	8J-9608	Pin	2	8J-9608	Pin	2	6K-0715	Pin
	2	3G-2580	Bearing	2	350-9370	Bearing	-	-	-	2	4K-3004	Bearing-Trunnion	2	3G-2582	Bearing	2	3G-2582	Bearing	-	-	-
	4	7K-9205	Seal	4	7K-9205	Seal	1	2K-0703	Bar	2	4K-3128	Bushing	4	7K-9204	Seal	4	7K-9204	Seal	-	-	-
	2	8T-4778	Lock Nut	2	8T-4778	Lock Nut	2	8T-4192	Bolt	8	6V-7687	Lock Nut	2	7X-2557	Bolt	2	7X-2557	Bolt	2	129-3180	Lock Nut
16M	2	7X-2558	Bolt	2	8T-6385	Bolt	-	-	-	8	8T-4910	Bolt	2	8T-4778	Lock Nut	2	8T-4778	Lock Nut	2	8T-5092	Bolt
	6	9N-4449	Spacer	6	9N-4449	Spacer	-	-	-	-	-	-	-	-	-	-	-	-	-	-	-
	9	9N-4450	Spacer	4	9N-4450	Spacer	-	-	-	-	-	-	-	-	-	-	-	-	-	-	-
	2	8J-9607	Pin	2	8J-9607	Pin	1	3K-8510	Pin	2	4K-3004	Bearing-Trunnion	2	8J-9608	Pin	2	8J-9608	Pin	2	6K-0715	Pin
16M3	2	3G-2580	Bearing	4	3G-2580	Bearing	3	3B-8489	Adapter	8	6V-7687	Lock Nut	2	3G-2582	Bearing	-	-	-	-	-	-
	4	9D-6585	Seal	8	7K-9205	Seal	1	623-2566	Bar	8	8T-4910	Bolt	4	7K-9204	Seal	-	-	-	-	-	
	2	7X-2557	Bolt	2	8T-6385	Bolt	2	8T-4192	Bolt	3	3B-8489	Adapter	2	7X-2557	Bolt	4	8T-4778	Lock Nut	2	6V-7687	Lock Nut
	2	176-5311	Lock Nut	4	8T-4778	Lock Nut	1	3K-8510	Pin	-	-	-	2	176-5311	Lock Nut	2	7X-2557	Bolt	2	8T-5092	Bolt
18	2	8J-9607	Pin	2	8J-9607	Pin	1	2K-4507	Bushing	-	-	-	2	8J-9608	Pin	2	8J-9608	Pin	2	6K-0715	Pin
	2	3G-2580	Bearing	2	3G-2580	Bearing	-	-	-	2	4K-3004	Bearing-Trunnion	2	3G-2582	Bearing	2	3G-2582	Bearing	-	-	-
	4	9D-6585	Seal	4	9D-6585	Seal	-	-	-	2	4K-3128	Bushing	4	9D-6584	Seal	4	7K-9204	Seal	-	-	-
	2	8T-4778	Lock Nut	2	8T-4778	Lock Nut	2	8T-4139	Bolt	8	8T-4910	Bolt	2	176-5311	Lock Nut	2	8T-4778	Lock Nut	2	8T-5092	Bolt
18M3	2	8J-9607	Pin	2	8J-9607	Pin	1	3K-8510	Pin	-	-	-	2	8J-9608	Pin	2	8J-9608	Pin	2	6K-0715	Pin
	2	3G-2580	Bearing	2	3G-2580	Bearing	1	2K-4507	Bushing	2	4K-3004	Bearing-Trunnion	2	3G-2582	Bearing	2	3G-2582	Bearing	-	-	-
	4	9D-6585	Seal	4	9D-6585	Seal	-	-	-	2	4K-3128	Bushing	4	9D-6584	Seal	4	7K-9204	Seal	-	-	-
	2	7X-2557	Bolt	2	8T-6385	Bolt	1	2K-0703	Bar	8	6V-7687	Lock Nut	2	7X-2557	Bolt	2	7X-2557	Bolt	2	6V-7687	Lock Nut
24M	2	176-5311	Lock Nut	2	8T-4778	Lock Nut	2	8T-4139	Bolt	8	8T-4910	Bolt	2	176-5311	Lock Nut	2	8T-4778	Lock Nut	2	8T-5092	Bolt
	2	8J-9607	Pin	2	8J-9607	Pin	1	3K-8510	Pin	-	-	-	2	8J-9608	Pin	2	8J-9608	Pin	2	6K-0715	Pin
	2	3G-2580	Bearing	2	3G-2580	Bearing	1	2K-4507	Bushing	2	4K-3004	Bearing-Trunnion	2	3G-2582	Bearing	2	3G-2582	Bearing	-	-	-
	4	9D-6585	Seal	4	9D-6585	Seal	-	-	-	2	4K-3128	Bushing	4	9D-6584	Seal	4	7K-9204	Seal	-	-	-
24	2	7X-2557	Bolt	2	8T-6385	Bolt	2	2K-0703	Bar	16	6V-7687	Lock Nut	2	8T-4174	Bolt	2	8T-4174	Bolt	2	3R-3602	Spacer
	2	8T-4778	Lock Nut	2	8T-4778	Lock Nut	4	8T-4192	Bolt	16	8T-4910	Bolt	2	8T-4778	Lock Nut	2	8T-4778	Lock Nut	2	6V-7687	Lock Nut
	-	-	-	-	-	-	-	-	-	-	-	-	-	-	-	-	-	-	-	-	-
	2	473-9735	Pin	2	473-9739	Pin	1	3K-8510	Pin	2	4K-3004	Bearing-Trunnion	2	473-9737	Pin	2	473-9743	Pin	2	270-3844	Pin
24	-	-	-	2	474-1036	Bearing	1	2K-4507	Bushing	2	4K-3128	Bearing	-	-	-	2	474-1035	Bearing	-	-	-
	-	-	-	4	235-7679	Seal	-	-	-	-	-	-	-	-	-	4	235-7679	Seal	-	-	-
	4	468-7855	Shim	4	468-7855	Shim	1	2K-0703	Bar	8	6V-7687	Lock Nut	2	7X-2557	Bolt	2	7X-2557	Bolt	2	6V-7687	Lock Nut
	24	474-5633	Shim	16	474-5633	Shim	2	2x 8T-4139	Bolt	8	8T-4910	Bolt	2	8T-4778	Lock Nut	2	8T-4778	Lock Nut	2	8T-5041	Bolt

PART NUMBER INDEX

FEATURE UPGRADES	PAGE #	MODEL	SERIES*	REFERENCE PART #
Advanced Control Joysticks	3	16 / 18 / 24	M / M3	463-6258
Advanced Control Joysticks	3	14	M / M3 / —	458-8701
Auto Shift	4	14 / 16 / 18	GC / M / M3 / —	Contact Cat Dealer
Cat® Grade Solutions ARO, Cross Slope, Cat Grade 3D	4	14 / 16 / 18 / 24	M / M3 / —	Contact Cat Dealer
Auto Articulation	5	14 / 16 / 18 / 24	GC / M / M3 / —	Contact Cat Dealer
Cold Weather Package	5	14 / 16 / 18 / 24	M / M3 / —	Contact Cat Dealer
E-Fence: Blade Avoidance	6	ALL	ALL	Contact Cat Dealer
Cab Powered Air System	6	24	M	615-8190
Cat Product Link™ - Cellular	7	14 / 16 / 18 / 24	GC / M / M3 / —	Contact Cat Dealer
Cat Product Link™ - Dual	7	14 / 16 / 18 / 24	GC / M / M3 / —	Contact Cat Dealer
Cat Production Measurement System	7	14 / 16	M3 / —	568-7127
Cat Production Measurement System	7	14/16/18	—	616-4319
Machine Security System (HRC)	7	14 / 16 / 18	M3 / —	393-6335
Machine Security System (LRC)	7	14 / 16 / 18	M3 / —	393-6336
Machine Security System - ALL	7	14 / 16 / 18	M3 / —	Contact Cat Dealer
Digital Blade Slope Meter	7	16	GC	592-9305
Remote Services	8	ALL	ALL	Contact Cat Dealer
Fire Suppression	8	16/18/24	M3	Contact Cat Dealer
Fire Suppression	8	16	GC	590-9256
High Performance Circle	9	24	M	626-0204
High Performance Circle	9	24	—	626-0205
ACCESSORIES	PAGE #	MODEL	SERIES	REFERENCE PART #
Mirror Extensions - Standard	11	14 / 16 / 18 / 24	M / M3 / —	466-5255
Mirror Extensions - Heated	11	14 / 16 / 18 / 24	M / M3 / —	466-5233
Forwarding Vision Cameras	11	24	—	536-0780
Rear View Camera	11	14	M	391-4396
Rear View Camera	11	16	M	425-3416
Rear View Camera	11	14 / 16 / 18	M3 / —	447-2229
Rear View Camera	11	24	—	536-8812
Rear View Camera (Requires Product Link)	11	16	GC	590-9236
Rear View Camera (Does Not Requires Product Link)	11	16	GC	590-9235
Rear Vision with Camera / Mirrors - Part of Regional Arrangement	11	14	M3 / —	536-9906
High Visibility Mirrors	11	16 / 18	M / M3 / —	351-4490
Visibility Arrangement	11	24	—	536-0780
Air Horn	12	14	M	355-1048
Air Horn	12	14 / 16	M3 / —	370-8465
Air Horn	12	16	M	300-1275
Air Horn	12	24	—	490-6423
Air Horn	12	16	GC	594-1463
Fast Fill Fuel	12	14	M	355-3348
Fast Fill Fuel	12	14	M3 / —	490-4792
Fast Fill Fuel	12	16	GC	594-0397
Sy-Klone Air Cleaner - Pre Cleaner	12	14	M	388-1718
Sy-Klone Air Cleaner - Pre Cleaner	12	14	M3 / —	368-2226
Sy-Klone Air Cleaner - Pre Cleaner	12	24	—	421-9581
Stroke Limiting Collar	12	16 / 18	M / M3 / —	519-2824
Stroke Limiting Collar	12	24	M / —	519-2825
Basic Dual Access Platform	13	24	—	469-9265
Enhanced Access Platform	13	16	M	425-5708
Enhanced Access Platform	13	16 / 18	M3 / —	375-3407
Platform Ladder (RHS & LHS)	13	16	M	425-5710

* — New nomenclature for MG Series

RHS - Right Hand Side

LHS - Left Hand Side

PART NUMBER INDEX

ACCESSORIES (CONTINUED)	PAGE #	MODEL	SERIES	REFERENCE PART #
Platform Ladder (RHS & LHS)	13	16 / 18	M3 / —	375-3406
Service Access Platform	13	16 / 18	M3 / —	462-6400
Door - Heated Glass (Enhanced Platform)	13	16 / 18 Specific	M3 / —	442-8722
Door - Heated Glass (Standard Ladder)	13	16 / 18 Specific	M3 / —	386-1311
Auto Lube	14	16	M	389-6066
Auto Lube	14	16 / 18	M3 / —	385-7552
Auto Lube	14	18	M3 / —	479-1625
Auto Lube	14	16	GC	590-9245
Object Detection	14	14 / 16 / 18 / 24	M / M3 / —	Contact Cat Dealer
Metallic DCM Wear Strips - Circle	14	14 / 16 / 18	M / M3 / —	352-1002
Metallic DCM Wear Strips - Moldboard	14	14 / 16 / 18	M / M3 / —	446-1523
Metallic DCM - Cylinder Insert	14	14	M / M3 / —	575-5623
Metallic DCM Wear Strips - Top	14	24	M / —	443-6839
Metallic DCM Wear Strips - Bottom	14	24	M / —	443-6838
Moldboard Pivot Pin (Lubricated)	14	14 / 16 / 18	M / M3 / —	567-7552
Jump Start Cables	15	ALL	ALL	8S-2632, 9S-3664
Tool Box	15	16	GC	590-2640
Seat Belt Indicator	15	ALL	ALL	513-5984
Seat Belt Monitoring	15	ALL	ALL	Contact Cat Dealer
Front Axle Steering Cylinder Guards	16	16	M / —	475-7639
Front Axle Steering Cylinder Guards	16	14	M3 / —	424-8974
Front Axle Steering Cylinder Guards	16	16 / 18	GC / M3	480-6660
Front Axle Steering Cylinder Guards	16	24	—	442-1960
Front Axle Steering Cylinder Guards HD	16	14	M / M3 / —	488-1611
Blade Extensions	16	14 / 16 / 18 / 24	M / M3 / —	Contact Cat Dealer
ATTACHMENTS	PAGE #	MODEL	SERIES	REFERENCE PART #
Rear Ripper	18	14	M	257-3574
Rear Ripper	18	14	M3 / —	521-9214
Rear Ripper	18	16 / 18	M3 / —	372-7830
Rear Ripper	18	16	M	264-3058
Transmission Guard	18	14	M / M3 / —	425-6468
Transmission Guard	18	16	M	365-6666
Transmission Guard	18	16 / 18	M3 / —	375-3408
Transmission Guard	18	24	M	306-8083
Transmission Guard	18	24	—	471-9755
Transmission Guard	18	16	GC	581-8964
Push Block / Counterweight	18	14	M3 / —	420-4809
Push Block / Counterweight	18	14 / 16	M	265-6737
Push Block / Counterweight	18	16 / 18	M3 / —	441-4488
Push Block / Counterweight	18	24	M	135-8283
Push Block / Counterweight - 24ft Moldboard	18	24	—	528-4874
Push Block / Counterweight - 28ft Moldboard	18	24	—	589-8577
Rear Fender and Guardrails	19	16 / 18	M3 / —	375-3402
Rear Fender and Guardrails	19	24	M	266-2418
Rear Fender and Guardrails	19	24	—	541-5159
Rear Fenders	19	14	M / M3 / —	255-5090
Rear Fenders	19	16	M	250-0166
Rear Fenders	19	16 / 18	M3 / —	375-3402
Rear Fenders	19	16	GC	596-9491
Heated Front Glass	20	16	M / M3	441-4489
Heated Right Side Glass	20	16 / 18	M / M3	380-3889
Stable Blade	20	14 Specific	M / M3 / —	Contact Cat Dealer
Compression Brake	22	16 Specific	M	Contact Cat Dealer
Steering Upgrade	22	16 Specific	M	494-9355
Steering Upgrade	22	24 Specific	M	435-4711

* — New nomenclature for MG Series

RHS - Right Hand Side

LHS - Left Hand Side

PART NUMBER INDEX

ATTACHMENTS (CONTINUED)	PAGE #	MODEL	SERIES*	REFERENCE PART #
Debris Guard	23	16 / 18 Specific	M3 / —	375-3404
High Speed Oil Drain	24	14 Specific	M3 / —	501-1165
High Speed Oil Drain	24	16	GC	595-4329
Engine Upgrade	—	24 Specific	M	435-4709
Engine Upgrade - Alternator & Air Conditioner Compressor	—	24 Specific	M	435-4710
Cat Detect Generic: Smart / Surround / Rear Camera System	—	ALL	ALL	Contact Cat Dealer
Circle Saver	—	14 Specific	M / M3 / —	488-2192
Circle Saver	—	16	GC	594-7179
Wheel Chocks	—	24 Specific	—	538-9643, 615-8193
Snow Cover	25	16 GC	M / M3 / —	611-7620
Hydraulic Fluid Monitoring	28	24 Specific	M	466-0822
Radiator Upgrade	28	24 Specific	M	453-3122
Transmission Upgrade	28	24 Specific	M	435-4712
Ripper Mounted Scarifier Board	29	24 Specific	M/ —	522-6224
Ripper Mounted Scarifier Board	29	16	M	522-6216
Solar Glass	29	24	M / —	Contact Cat Dealer
LIGHT EMITTING DIODE (LED) LIGHTS	PAGE #	MODEL	SERIES*	REFERENCE PART #
Dome	36	14 / 16 / 18	GC / M / M3 / —	375-1478
Dome	36	24	M / M3 / —	375-1478
Flood – Front & Rear Working	36	14	M3 / —	550-2445
Flood – Front & Rear Working	36	14 / 16	M / M3 / —	386-1722
Flood – Front & Rear Working	36	16	—	383-8634
Flood – Front & Rear Working	36	16	M	353-9420
Flood – Front & Rear Working	36	18	M3 / —	541-6340
Flood – Front & Rear Working	36	24	M	353-9420
Flood – Front & Rear Working	36	24	—	441-0314
Flood – Front & Rear Working	36	16	GC	589-0465
Flood - Front & Rear Working (narrow)	36	16	GC / M3 / —	589-0465
Headlight RH	36	14 / 16 / 18	GC / M3 / —	525-5297
Headlight LH	36	14 / 16 / 18	GC / M3 / —	525-5298
Headlight - High Beam	36	24	M	366-7803
Headlight - High Beam	36	24	—	441-0315
Headlight - Low Beam	36	24	M	381-8979
Headlight - Low Beam	36	24	—	451-2535
Rear Turn Signal	36	14 / 16	M	201-5464
Rear Turn Signal	36	14 / 16	GC / —	379-3416
Rear Turn Signal	36	14 / 16 / 18 / 24	M3 / —	395-2113
Rear Turn Signal	36	24	M	334-5410
Stop & Tail	36	14 / 16 / 24	M	334-8049
Stop & Tail	36	14 / 24	M3 / —	395-2113
Stop & Tail	36	14 / 16 / 18	M3 / —	259-8450
Warning Beacon Mounting	36	14 / 16	M	361-3137
Warning Beacon Mounting	36	14 / 16 / 18	M3 / —	421-7812
Warning Beacon Mounting	36	24	M	323-1692
Cab	36	14	M3 / —	550-2446
Cab	36	14 / 16	M	386-1722, 386-1723
Cab	36	16 / 18	M3 / —	386-1717
Cab	36	24	M	441-0314
Reverse Lamp	36	24	GC / —	379-3416
Turn Signal	36	24	M	201-5464 334-5410

* — New nomenclature for MG Series

RHS - Right Hand Side

LHS - Left Hand Side

NOTES

THANK YOU FOR CHOOSING A CAT[®] MOTOR GRADER.

Cat[®] Motor Graders offer world-class cab design, easy-to-use controls and advanced electronics and hydraulics to give you optimum productivity for any application. This guide will provide you with a quick reference for the available aftermarket components and the common maintenance parts you need to keep your Motor Grader working hard for you.

AFTERMARKET COMPONENTS

Customize your Cat Motor Grader to fit your needs with a variety of specialized products designed for your industry and application. These features, accessories and attachments help optimize and maintain your machine, so you can get the most out of every use.

COMMON MAINTENANCE PARTS

Preventive maintenance helps extend the life of your machine and protect your investment. Only Cat Parts are made to match your machine's specific filtration needs, lubrication requirements and exact maintenance cycles. That's why our parts kits make it easier to maintain your machine and keep it running at peak performance.

LET'S DO THE WORK.™

PEBJ0159-02
January
2024

© 2024 Caterpillar. All Rights Reserved. CAT, CATERPILLAR, LET'S DO THE WORK, their respective logos, "Caterpillar Corporate Yellow", the "Power Edge" and Cat "Modern Hex" trade dress as well as corporate and product identity used herein, are trademarks of Caterpillar and may not be used without permission. VisionLink is a trademark of Trimble Navigation Limited, registered in the United States and in other countries.

