



## 125 ekW – 200 ekW

### 60 Hz

Standby	Prime
125 ekW	114 ekW
150 ekW	135 ekW
175 ekW	158 ekW
200 ekW	-

*Image shown may not reflect actual configuration*

## BENEFITS & FEATURES

### CAT® GENERATOR SET PACKAGE

Cat generator set packages have been fully prototype tested and certified torsional vibration analysis reports are available. The packages are designed to meet the NFPA 110 requirement for loading, conform to the ISO 8528-5 steady state and fill transient response requirements.

### CAT DIESEL ENGINES

The four-cycle Cat diesel engine combines consistent performance with excellent fuel economy and transient response that meets or exceeds ISO 8528-5. The engines feature a reliable, rugged, and durable design that has been field proven in thousands of applications worldwide in emergency standby installations.

### COOLING SYSTEM

The cooling system has been designed and tested to ensure proper generator set cooling, and includes the radiator, fan, belts, and all guarding installed as standard. Contact your Cat dealer for specific ambient and altitude capabilities.

### GENERATORS

The generators used on Cat packages have been designed and tested to work with the Cat engine. The generators are built with robust Class H insulation and provide industry-leading motor starting capability and altitude capabilities.

### EMCP CONTROL PANELS

The EMCP controller features the reliability and durability you have to come to expect from your Cat equipment. The EMCP 4 is a scalable control platform designed to ensure reliable generator set operation, providing extensive information about power output and engine operation. EMCP 4 systems can be further customized to meet your needs through programming and expansion modules.

## SPECIFICATIONS

### ENGINE SPECIFICATIONS

Engine Model	Cat® C7.1 ACERT In-line 6, 4-cycle diesel
Bore x Stroke	105mm x 127mm (4.1in x 5.0 in)
Displacement	7.01 L (428 in <sup>3</sup> )
Compression Ratio	16.7:1
Aspiration	Turbocharged Air-to-Air-Aftercooled
Fuel Injection System	Electronic, Common Rail
Governor	Electronic ADEM™ A4
Emission Certifications	US EPA TIER III Non-Road

### GENERATOR SET SPECIFICATIONS

Alternator Design	Brushless Single Bearing, 4 Pole
Stator	2/3 Pitch
No. of Leads	12
Available Voltage Options	600/480/440/240/220V
Frequency	60Hz
Alternator Voltage	12V
Alternator Insulation & IP	Class H; IP23
Standard Temperature Rise	125/130 Deg C
Available Excitation Options	Self-Excited, AREP
Voltage Regulation, Steady State+/-	≤1%

## STANDARD EQUIPMENT

Air inlet system	Aftercooler core Turbocharger
Control panels	EMCP4.2 control panel
Cooling system	Radiator and cooling fan complete with protective guards Standard ambient temperatures up to 50degC (122degF) 50% coolant antifreeze/corrosion inhibitor Coolant Reservoir
Fuel system	Primary & secondary fuel filters Fuel priming pump Flexible fuel lines
Generators and generator attachments	Brushless, self-excited 2/3 pitch, random wound IP23 Protection Insulation Class H and temperature rise Integrated Voltage Regulator
Governing system	Cat Electronic Governor (ADEM A4)
Protection System	Safety Shutoff – Low Oil Pressure Safety Shutoff – Overspeed Coolant Level Sensor
Starting/charging system	12-Volt Electric Starting Motor Batteries with rack & cables
General	Paint – Caterpillar Yellow except rails and radiators gloss black

## OPTIONAL EQUIPMENT

Air inlet system	Single Element air filter Cartridge type air filter
Exhaust	Industrial, residential, critical mufflers
Control panels	Remote Annunciators Discrete I/O Module Earth (Ground) Fault Relay
Circuit Breakers	3-Pole 100% Rated – Single & Dual breaker combination
Enclosures	Sound Attenuated (SA) – Level 1 & Level 2 Weather Protective Aluminum Enclosure
Cooling system	Radiator Stone guards
Mufflers	Industrial grade (10 dBA) Residential and Critical grade (25 dBA) & 35 dBA mufflers
Fuel System	Sub Tank Bases: 408, 777 Gal
Generators and generator attachments	Excitation – Self Excitation –PMG Oversize
Starting/charging system	Standard Battery Set
Certifications	UL2200 Listed Certification of Compliance – IBC Seismic
General	Tool Set

## WEIGHTS & DIMENSIONS

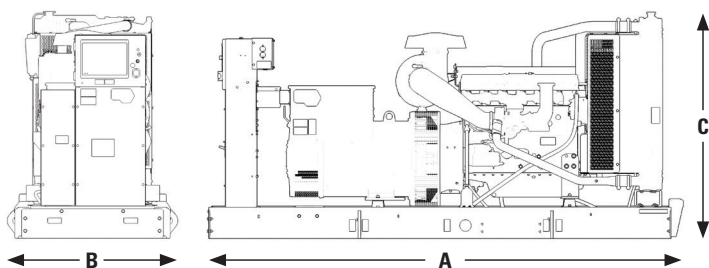

**Note:** General configuration not to be used for installation.  
See general dimension drawings for detail.

Standby Ratings	Dim "A" mm (in)	Dim "B" mm (in)	Dim "C" mm (in)	Generator Set Weight kg (lb)
<b>125 ekW</b>	3039 (120)	1110 (44)	1476 (58)	1500 (3307)
<b>150 ekW</b>	3039 (120)	1110 (44)	1476 (58)	1500 (3307)
<b>175 ekW</b>	3039 (120)	1110 (44)	1476 (58)	1500 (3307)
<b>200 ekW</b>	3039 (120)	1110 (44)	1476 (58)	1500 (3307)



*Image shown may not reflect actual configuration*

## Integral and Sub Base Fuel Tanks

### Features

- UL Listed for United States (UL 142) and Canada (CAN/ULC S601)
- Facilitate compliance with NFPA 30 code, NFPA 37 and 110 standards and CSA C282 code and B139-09 standard
- Welded, heavy steel gauge construction with a containment basin sized as a minimum 110% of the tank
- Gloss black polyester triglycidyl isocyanurate
- (TGIC) powder coating
- Dedicated external customer interface area with access to the 4" (101.6 mm) fuel fill, visual level gauge, normal and emergency vents
- Rear electrical stub-up area with removable access panel
- Removable engine supply and return dip tubes
- Two additional 1" (25.4 mm) ports for customer use
- Tanks are rated to safely support the weight of the generator
- 8 gal (30.3 L) drip pan for oil and coolant (for generator sets up to 60 ekW only)
- Standard NPT tank fittings
- UL listed emergency vents sized as per UL standards 3" (76.2 mm), 4" (101.6 mm), and 5" (127 mm) NPT
- Normal atmospheric vent 1-1/4" (31.75 mm)
- Top-mounted fuel level sensor with control panel alarms
- Top-mounted leak detection switch
- Lockable fuel fill cap, 4" (101.6 mm) NPT

### Description

- Dual wall, secondary containment
- Pressure tested to UL requirements
- Fuel tank mounts directly below generator skid base
- Modular tank design is compatible with all factory units open and enclosed

### Options

- Emergency vent and normal vent extension kits 12' (3.66 m)
- 5 gal (18.9 L) spill containment
- Overfill prevention valve
- Tank riser to allow for visual secondary containment leak inspection
- Drop tube

## Sub-Base Fuel Tank Capacities with Fuel Tank Dimensions

Engine Model	Tank Feature Code	Generator Set Rating kW	Est. Run Time hrs	Fillable Capacity		Usable Capacity		Vent in	Length 'L'		Width 'W'		Height 'H'		Weight (Dry)	
				L	gal	L	gal		in	mm	in	mm	in	mm	in	kg
C7.1	FSBTI24	125	40	1520	402	1495	395	4	4035	158.9	100	39.4	647	25.5	720	1587
		150	35													
		175	29													
		200	27													
	FSBTJ48	125	78	2940	777	2918	771	5	5035	198.2	100	39.4	933	36.7	1145	2524
		150	68													
		175	57													
		200	52													

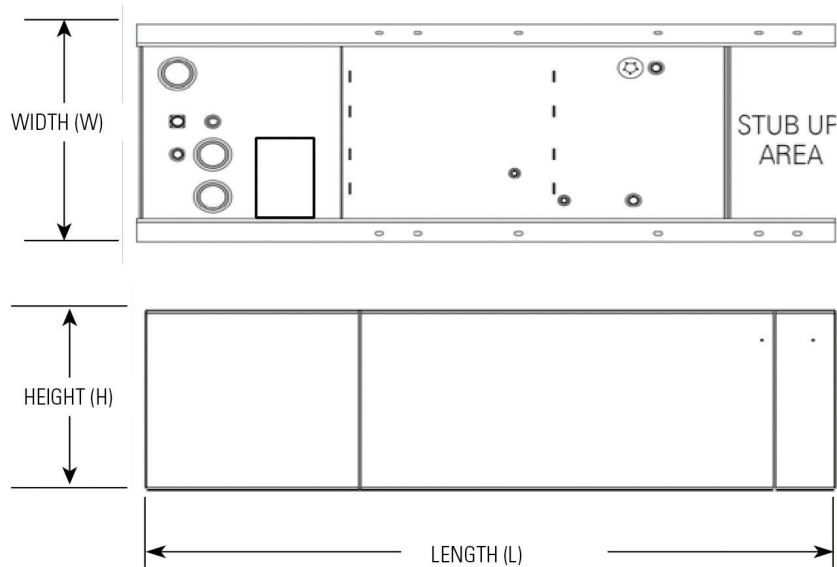

Tanks are UL Listed and constructed in accordance with UL Standard for Safety UL 142, Steel Aboveground Tanks for Flammable and Combustible Liquids and Canada CAN/ULC Fabricated Steel above ground Horizontal Tanks for Flammable and Combustible Liquids

Fuel tanks facilitate compliance with the following United States NFPA Code and Standards:

N FPA 30: Flammable and Combustible Liquids code

NFPA 37: Standard for the Installation and Use of Stationary Combustion Engines and Gas Turbines

NFPA 110: Standard for Emergency and Standby Power Systems

Fuel tanks facilitate compliance with the following Canadian Standard and Code:

CSA C282 – Emergency Electrical Power Supply for Buildings

CSA B139-09 – Installation Code for Oil-Burning Equipment



*Image shown may not reflect actual configuration*

## Weather Protective and Sound Attenuated Enclosures

60Hz

### Features

#### Robust/Highly Corrosion Resistant Construction

- Stainless steel flush fitting latches and hinges tested and proven to withstand extreme conditions of corrosion
- Zinc plated or stainless steel fastener

#### Excellent Access

- Single side access for service and controls
- All non-service sides have removable doors and/or panels
- Radiator fill access
- Lube oil and coolant drains piped to the exterior of the enclosure base
- Large cable entry area for installation ease
- Double doors on both sides
- Vertically hinged doors with solid bar door stays to hold doors in place when open

#### Security and Safety

- Lockable access doors which give full access to control panel and breaker
- Cooling fan and battery charging alternator fully guarded
- Fuel fill, oil fill, and battery can only be reached via lockable access
- Stub-up area is rodent proof.

#### Transportability

- These enclosures are of extremely rugged construction to withstand outdoor exposure and rough handling common on many construction sites. The sound deadening material is of a self-extinguishing design
- This range of enclosures are designed on modular principles with many interchangeable components permitting on site repair

### Options

- Weather Protective – constructed with 16 gauge steel; industrial silencer mounted within the main enclosure body.
- Sound Attenuated Level 1 – constructed with 16 gauge steel; weather protective with critical silencer - silencer mounted in separate upward discharging radiator hood.
- Sound Attenuated Level 2 – constructed with 16 gauge steel; weather protective with critical silencer and 100% lined with sound deadening material – silencer mounted in separate upward discharging radiator hood.
- Sound Attenuated Aluminum constructed with 14 gauge Aluminum 5052 grade. Weather protective with critical silencer and 100% lined with sound deadening material – silencer mounted in separate upward discharging radiator hood.
- Caterpillar Yellow\* or white paint.
- UL Listed sub base tanks.
- Externally mounted emergency stop button.
- Seismic certification per applicable building codes: IBC 2000, IBC 2003, IBC 2006, IBC 2009, IBC 2012, CBC 2007, CBC 2010.
- IBC certification for 180 mph wind loading

\*Not available with Aluminium enclosures

## Enclosure Sound Pressure Levels (SPL) at 100%

Weather Protective Enclosure		Cooling Air Flow Rate		SPL @7m (23ft)
Model	Standby ekW	m <sup>3</sup> /s	cfm	dBA
D125-8	125	4.6	9676	78
D150-10	150	4.6	9676	79
D175-4	175	5.9	12431	84
D200-2	200	5.9	12431	89
SA Level 1 Enclosure				
Model	Standby ekW	m <sup>3</sup> /s	cfm	dBA
D125-8	125	4.2	8899	74
D150-10	150	4.2	8899	74
D175-4	175	5.6	11830	78
D200-2	200	5.5	11654	81
SA Level 2 Enclosure				
Model	Standby ekW	m <sup>3</sup> /s	cfm	dBA
D125-8	125	4.2	8899	74
D150-10	150	4.2	8899	74
D175-4	175	5.2	11018	74
D200-2	200	5.1	10806	75
SA Aluminium Enclosure				
Model	Standby ekW	m <sup>3</sup> /s	cfm	dBA
D125-8	125	4.2	8899	74
D150-10	150	4.2	8899	75
D175-4	175	5.2	11018	75
D200-2	200	5.1	10806	75

**Note:** The sound pressure level data shown above is quoted as free field and is for guidance only. Actual levels produced may vary according to site conditions

## Enclosure Weights

Model	Standby ekW	WP Industrial		SA Level 1		SA Level 2		SA Aluminium	
		kg	lb	kg	lb	kg	lb	kg	lb
D125-8	125	348	768	393	867	406	896	176	387
D150-10	150								
D175-4	175								
D200-2	200								

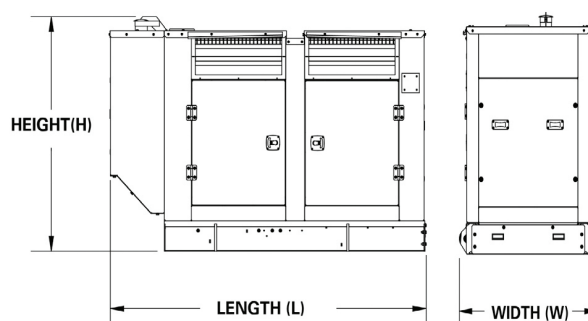

## Enclosure Dimensions: Skid Bases

Engine Model	Generator Set Rating ekW	Enclosure	Width 'W'		Length 'L'		Height 'H'	
			mm	in	mm	in	mm	in
C7.1	125	WP	1110	43.7	3204	126.1	1773	69.8
	150							
	175							
	200							
	125	SA Level 1, SA Level 2 and SA Aluminium	1110	43.7	3659	144.1	1852	72.9
	150							
	175							
	200							

## Enclosure Dimensions: UL Listed Sub Tank Base

Engine Model	Generator Set Rating ekW	Enclosure	402 Gallon Sub Base Tank				777 Gallon Sub Base Tank			
			Length 'L'		Height 'H'		Length 'L'		Height 'H'	
			mm	in	mm	in	mm	in	mm	in
C7.1	125	WP	4035	158.9	2420	95.3	5035	198.2	2706	106.5
	150									
	175									
	200									
	125	SA Level 1, SA Level 2 and SA Aluminium	4035	158.9	2499	98.4	5035	198.2	2785	106.5
	150									
	175									
	200									

**Note:** Weight includes oil and coolant but not fuel

**Ref:** WP1A, WP1B, WP1C, SATCBA, SATCBB, SAT, CBC, SATFBA, SATFBB, SATFBC, ENCAL02, ENCAL03, ENCAL04.

## EMCP 4 CONTROL KEY FEATURES

### EMCP 4 control features

- Run/Auto/Stop Control
- Speed and Voltage Adjust
- Engine Cycle Crank
- 24-volt DC operation
- Environmental sealed front face
- Text alarm/event descriptions

### Digital indication for:

- RPM
- DC volts
- Operating hours
- Oil pressure (psi, kPa or bar)
- Coolant temperature
- Volts (L-L & L-N), frequency (Hz)
- Amps (per phase & average)
- ekW, kVA, kVAR, kW-hr, %kW, PF (4.2 only)

### Warning/shutdown with common LED indication of:

- Low oil pressure
- High coolant temperature
- Overspeed
- Emergency Stop
- Failure to start (overcrank)
- Low coolant temperature
- Low coolant level



### Programmable protective relaying functions:

- Generator phase sequence
- Over/Under voltage (27/59)
- Over/Under Frequency (81 o/u)
- Reverse Power (kW) (32) (4.2 only)
- Reverse reactive power (kVAr) (32RV)
- Overcurrent (50/51)

### Communications:

- 4 digital inputs & 4 relay outputs (4.1)
- 6 digital inputs & 8 relay outputs (4.2)
- 12 digital inputs & 8 relay outputs (4.4)
- Customer data link (Modbus RTU) (4.2 only)
- Accessory module data link (4.2 only)
- Serial annunciator module data link (4.2 only)
- Emergency stop pushbutton

### Compatible with the following:

- Digital I/O module
- Local Annunciator
- Remote CAN annunciator
- Remote serial annunciator

## FINANCING

Caterpillar offers an array of financial products to help you succeed through financial service excellence. Options include loans, finance lease, operating lease, working capital, and revolving line of credit. Contact your local Cat dealer for availability in your region.

## WORLDWIDE PRODUCT SUPPORT

Cat dealers provide extensive post-sale support including maintenance and repair agreements. Cat dealers have over 1,800 dealer branch stores operating in 200 countries. The Caterpillar<sup>®</sup> SOS<sup>SM</sup> program effectively detects internal engine component condition, even the presence of unwanted fluids and combustion by-products.

# LET'S DO THE WORK.™