



Image shown may not reflect actual configuration.

200 ekW – 300 ekW

60 Hz

	Standby	Prime
DE200SE0	200 ekW	180 ekW
DE250SE0	250 ekW	225 ekW
DE275SE0	275 ekW	250 ekW
DE300SE0, E3	300 ekW	270 ekW

BENEFITS & FEATURES

CAT® GENERATOR SET PACKAGE

Cat generator set packages have been fully prototype tested and certified torsional vibration analysis reports are available. The packages are designed to meet the NFPA 110 requirement for loading, conform to the ISO 8528-5 steady state and fill transient response requirements.

CAT DIESEL ENGINES

The four-cycle Cat diesel engine combines consistent performance with excellent fuel economy and transient response that meets or exceeds ISO 8528-5. The engines feature a reliable, rugged, and durable design that has been field proven in thousands of applications worldwide in emergency standby installations.

COOLING SYSTEM

The generators used on Cat packages have been designed and tested to work with the Cat engine. The generators are built with robust Class H insulation and provide industry-leading motor starting capability and altitude capabilities.

GENERATORS

The generators used on Cat packages have been designed and tested to work with the Cat engine. The generators are built with robust Class H insulation and provide industry-leading motor starting capability and altitude capabilities.

GCCP CONTROL PANELS

The GCCP controller features the reliability and durability you have to come to expect from your Cat equipment. Monitoring an extensive number of engine parameters, the controller will display warnings, shutdown and engine status information on the back-lit LCD screen, illuminated LEDs and remote PC. The controllers offer extensive number of flexible inputs, outputs and extensive engine protections so the system can be easily adapted to meet the most demanding industry requirements.

SPECIFICATIONS

ENGINE SPECIFICATIONS

Engine Model	Cat® C9 In-line 6, 4-cycle diesel
Bore x Stroke	112 mm x 149 mm (4.4 in x 5.9 in)
Displacement	8.8 L (538 in ³)
Compression Ratio	16.1:1
Aspiration	Turbocharged Air-to-Air Aftercooled
Fuel Injection System	MEUI
Governor	Electronic ADEM™ A4
Emission Certifications Options	Non-Regulated & EU IIIA

GENERATOR SET SPECIFICATIONS

Alternator Design	Brushless Single Bearing, 4 Pole
Stator	2/3 Pitch
Available Voltage Options	220V/240V/380V/440V/480V
Frequency	60 Hz
Engine Alternator Voltage	24V
Alternator Insulation & IP	Class H; IP21; IP23(Optional)
Standard Temperature Rise	125 Deg C
Available Excitation Options	Self-Excited, PMG
Voltage Regulation, Steady State+/-	≤1%

STANDARD EQUIPMENT

Air inlet system	Air cleaner Light duty with disposable paper filter
Control panels	GCCP1.3 control panel
Cooling system	Radiator and cooling fan with guard Coolant drain line with valve Fan drive, battery charging alternator drive – Caterpillar extended life coolant
Telematics	PL444 4G LTE
Exhaust system	Stainless steel exhaust flex, gaskets, rain cap & SAE exhaust flange
Fuel system	Standard open set fuel tank/base supplied Base, formed steel with single wall integral 8-hour fuel tank
Generators and generator attachments	IP23 protection Voltage regulator (single phase sensing) Power center, IP22 Segregated low voltage (AC/DC) wiring panel Mandatory option circuit breaker, IEC, 3 pole, mounted in Power-center
Governing system	Cat electronic governor (ADEM A4)
Lube system	Oil cooler Lubricating oil Oil drain valves
Starting/charging system	24V battery with rack and cables
General	Engine and alternator pre-paint, Caterpillar Yellow

OPTIONAL EQUIPMENT

Air inlet system	Single element air cleaner Dual element air cleaner
Control panels	GCCP1.4 control panel Local & remote annunciator
Telematics	PLG601, PLG641
Circuit breakers	3-Pole 100% rated – Single (manual & motorised) 4-Pole 100% rated – Single (manual & motorised)
Enclosures	Sound attenuated level 1 & level 2 High ambient enclosures
Cooling system	Stone guards
Radiator	High ambient radiator
Fuel storage	8 Hr single & dual wall 8 Hr dual wall – heavy duty 24 Hr dual wall – heavy duty
Generators and generator attachments	Space heater control Permanent magnet generator Ingress protection R-Frame auxiliary winding LC & A-Frame coastal insulation protection Optional LC-Frame
Mounting system	Captive linear vibration isolators
Starting/charging system	Battery chargers Jacket water heater
General	Tool set

WEIGHTS & DIMENSIONS

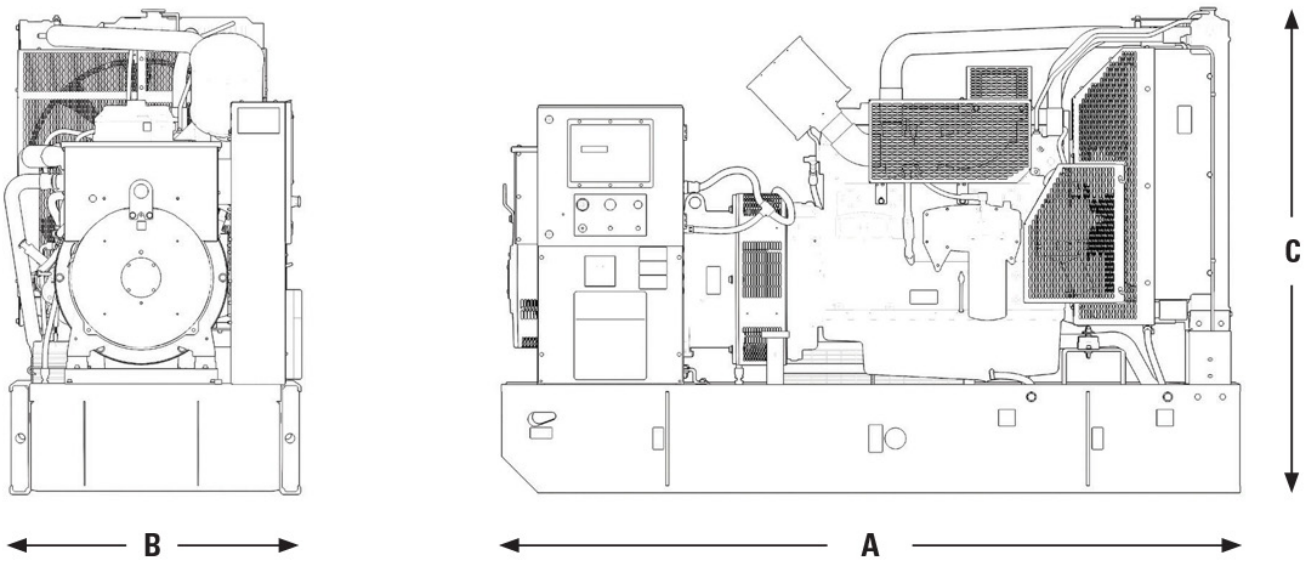

Note: General configuration not to be used for installation. See general dimension drawings for detail.

Genset Package		Length "A" mm (in)	Width "B" mm (in)	Height "C" mm (in)	Open Std. Generator Set Weight (Dry) Kg (lb)	Enclosed Generator Set Weight (Dry) Kg (lb)
Standby	Prime					
200 ekW	180 ekW	2662 (104.8)	1030 (40.5)	1754 (69)	2096 (4620.8)	3385 (7462.6)
250 ekW	225 ekW	2662 (104.8)	1030 (40.5)	1754 (69)	2096 (4620.8)	3385 (7462.6)
275 ekW	250 ekW	2662 (104.8)	1030 (40.5)	1754 (69)	2110 (4651.7)	3429 (7559.6)
300 ekW	275 ekW	2662 (104.8)	1030 (40.5)	1754 (69)	2261 (4984.6)	3429 (7559.6)

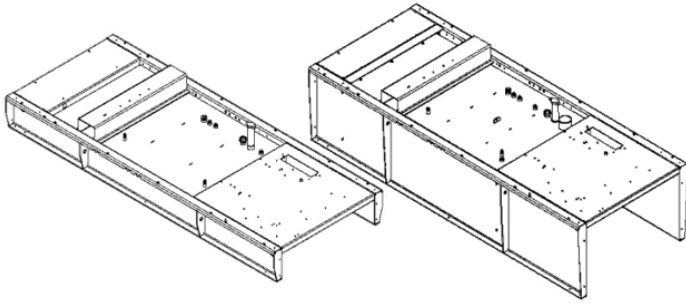

Image shown may not reflect actual configuration.

Integral Fuel Tank Bases

230 – 330 kVA 50 Hz

180 – 300 kW 60 Hz

FEATURES

- 8 Hour Fuel tank design provides capacity for thermal expansion of fuel.
- Integral diesel fuel tank is incorporated into the generator set base frame.
- Direct reading fuel level gauge.
- Fuel supply dip tubes positioned so as not to pick up fuel sediment.
- Fuel return and supply dip tubes are separated by an internal baffle to prevent recirculation of heated return fuel.
- Raised Fuel fill neck for easy access 50.8 mm (2 in)
- Tanks designed with a Max pressure head of 1.4m above tank top.
- Heavy gauge steel 4point lifting gussets suitable for easy lifting of Genset package
- Polyester powder coating – Gloss black textured finish
- Primary tanks are equipped with customer connections for remote fuel transfer in (1”), return (1.5”) and vent (1”)
- Right side stub-up.

SINGLE WALL TANKS

A. Standard Duty Narrow and Wide Base options

- Construction: 4 mm (0.16 in) steel plate side channels and 3 mm (0.12 in) sheet steel tank design
- Standard offering for open and Level 1 & 2, Level 1HA enclosed generator sets.

B. Heavy Duty wide base option (FTSW001)

- Construction: 6 mm (0.24 in) steel plate side channels with end plates and 3 mm (0.12 in) sheet steel tank design
- Available for Level 2, Level 1HA enclosed generator sets

DUAL WALL TANKS

- Secondary containment – closed top design
- Welded steel basin designed to contain a minimum of 110% of primary tank capacity (total fluid containment)
- Sloped top tank plate to front to contain accidental coolant, oil and fuel spillages with front ½” closed drain sockets and 4” open rear access drain socket. Multi containment setup. Auto drain with drip tray for service, with separate full fuel containment or Full containment of all fluids by removing ½” front drain plugs.
- Available for Level 2, Level 1HA enclosed generator sets.

FTBDW20 Standard Duty Dual Wall

- Construction: 4 mm (0.16 in) steel plate side channels and 3 mm (0.12 in) sheet steel tank design.

FTBDWH1 Heavy Duty Dual Wall

- Heavy construction 6 mm (0.24 in) steel plate side channels with End plates and 4mm (0.16 in) sheet steel tank design.

FTBDWH2 24-Hr Heavy Duty Dual Wall

- Heavy construction 6 mm (0.24 in) steel plate side channels with End plates and 4mm (0.16 in) sheet steel tank design

OPTIONS

- Low fuel level alarm
- Low fuel level shutdown
- High fuel level alarm

PACKAGE DIMENSIONS & CAPACITIES

250-275 kVA 180-300 kW OPEN	Single/ Dual Wall	Fillable Capacity		Usable Capacity		Dry Weight [#]		Width [†]		Length		Height		Package Height [*]	
		L	gal	L	gal	kg	lb	mm	in	mm	in	mm	in	mm	in
Standard Tank	Single	528	140	503	133	277	611	1030	40.6	2662	104.8	425	16.7	1818	72
MTSK001	Single	N.A	-	N.A	-	153	337	1030	40.6	2662	104.8	250	16.7	1643	65
SA L1 Enclosure															
Standard Tank	Single	473	125	438	116	316	697	1200	47.2	3483	137.2	350	13.8	1867	73.5
SA L2 & L1 High Ambient Enclosures															
Standard Tank	Single	542	143	508	134	388	855	1400	55.1	3498	137.7	350	13.8	2032	80
Standard Duty Dual Wall	Dual	530	140	501	132	568	1252	1400	55.1	3498	137.7	450	17.7	2132	84
Heavy Duty Wide Base	Single	542	143	508	134	454	1001	1410	55.5	3498	137.7	450	17.7	2032	80
Heavy Duty Dual Wall	Dual	530	140	501	132	647	1427	1410	55.5	3498	137.7	450	17.7	2132	84
Heavy Duty Dual Wall (24 hr)	Dual	1381	365	1250	330	945	2083	1400	55.1	3498	137.7	830	32.7	2512	99

Notes:

*The heights listed above do not include lumber used during manufacturing and shipping.

[#]Dry weight is for tank only. Does not include additions or removals required by price list.

All fuel tanks are shipped "installed."

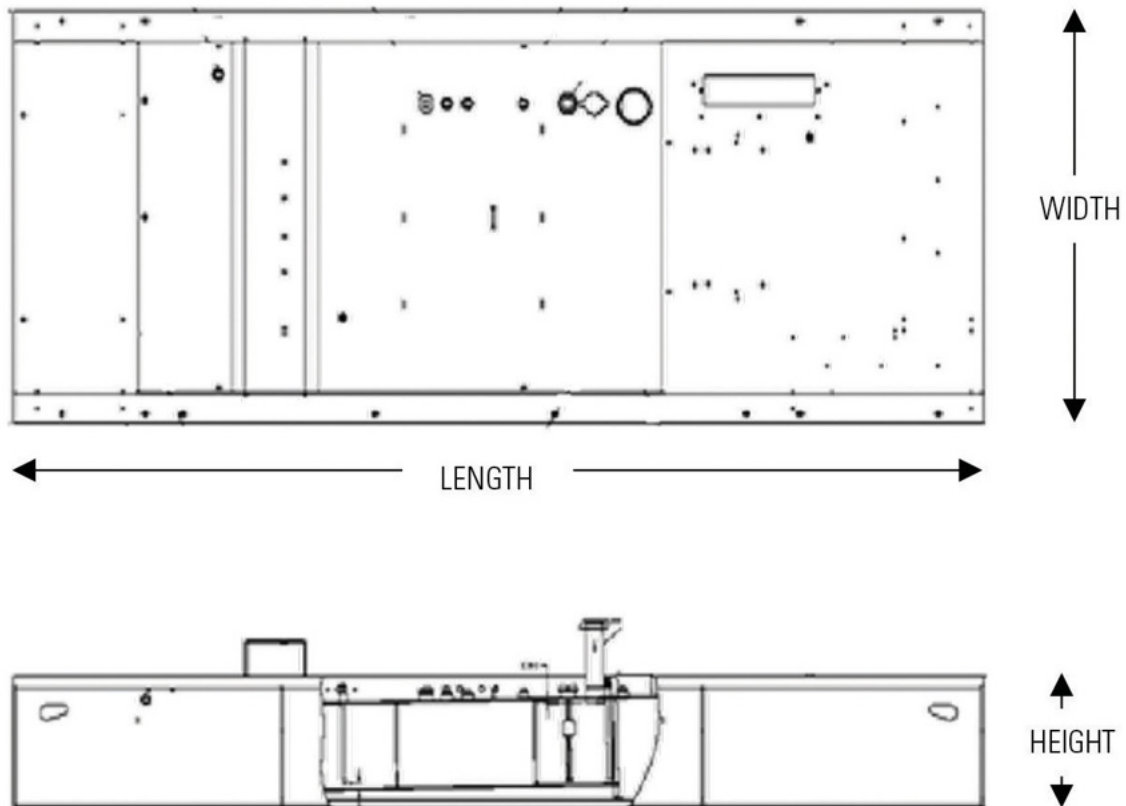



SOUND ATTENUATED & HIGH AMBIENT ENCLOSURES

Image shown may not reflect actual configuration.

FEATURES

Robust/Highly Corrosion Resistant Construction

- Galvanized steel construction
- Galvanized steel construction level 2 enclosure meeting EU noise levels
- Enclosures Designed for 43°C Ambient Capability
- Factory installed Standard Fabricated 4 mm steel base frame with integral fuel tank
- Environmentally friendly, polyester powder baked paint
- Compression door latches giving solid door seal
- Zinc-plated or black-coated stainless steel fasteners
- Internally-mounted critical exhaust silencing system

Excellent Access

- Large cable entry area for installation ease
- Accommodates side mounted breaker and control panel
- Vertically-hinged double doors on both sides
- Removable ducts providing maintenance access with enclosure in place
- Lube oil and coolant drains piped to base frame side rail, on exterior
- Radiator fill cover

Security and Safety

- Lockable access doors which give full access to control panel and breaker
- Cooling fan and battery charging alternator fully guarded
- Fuel fill, oil fill, and battery can only be reached via lockable access
- Externally-mounted emergency stop button
- Designed for spreader-bar lifting to ensure safety
- Control panel viewing window
- Stub-up area is rodent proof

Options

- Caterpillar yellow or white paint
- Heavy Duty Fabricated 6 mm Steel base frame

ENCLOSURE PACKAGE OPERATING CHARACTERISTICS

A. Sound Attenuated – Level 1

Model	Hz	kVA	SB/PP	Sound Pressure Levels dBA				Air Flow Rate		Ambient Capability @100% Load	
				1m (3.3 ft)		7m (23 ft)		m³/s	cfm	°C	°F
				75% Load	100% Load	75% Load	100% Load				
DE250E0	50	250	SB	83	84	73	74	4.5	9535	47	117
	50	230	PP	83	84	73	74	4.5	9535	50	122
DE275E0	50	275	SB	83	84	73	74	4.5	9535	44	111
	50	250	PP	83	84	73	74	4.5	9535	47	117
DE200SE0	60	250	SB	88	88	78	79	6.0	12173	52	125
	60	225	PP	88	88	78	79	6.0	12173	55	131
DE250SE0	60	313	SB	88	89	79	79	6.0	12173	45	112
	60	281	PP	88	89	78	79	6.0	12173	48	119

B. Sound Attenuated – Level 2

Model	Hz	kVA	SB/PP	Sound Pressure Levels dBA				Air Flow Rate		Ambient Capability @100% Load	
				1m (3.3 ft)		7m (23 ft)		m³/s	cfm	°C	°F
				75% Load	100% Load	75% Load	100% Load				
DE250E0	50	250	SB	75.2	76.0	67.3	68.5	4.6	9747	49	121
	50	230	PP	75.0	75.8	67.1	68.1	4.6	9747	52	125
DE275E0	50	275	SB	75.5	76.3	67.7	68.9	4.6	9747	47	116
	50	250	PP	75.2	76.0	67.3	68.5	4.6	9747	49	121
DE275E3	50	275	SB	75.0	76.6	67.6	69.3	4.6	9747	49	120
	50	250	PP	74.7	76.0	67.1	68.7	4.6	9747	52	126
DE300E0	50	300	SB	75.7	76.6	68.0	69.3	4.6	9747	44	111
	50	275	PP	75.5	76.3	67.7	68.9	4.6	9747	47	116
DE300E3	50	300	SB	75.4	77.2	68.1	70.0	4.6	9747	46	114
	50	275	PP	75.0	76.6	67.6	69.3	4.6	9747	49	120
DE330E0	50	330	SB	76.0	76.9	68.4	69.7	4.6	9747	40	104
	50	300	PP	75.7	76.6	68.0	69.3	4.6	9747	44	111
DE300SE3	60	375	SB	79.7	81.3	72.0	74.2	5.5	11654	44	111
	60	338	PP	79.2	80.6	71.3	73.3	5.5	11654	48	118

C. High Ambient – Level 1

Model	Hz	kVA	SB/PP	Sound Pressure Levels dBA				Air Flow Rate		Ambient Capability @100% Load	
				1m (3.3 ft)		7m (23 ft)		m ³ /s	cfm	°C	°F
				75% Load	100% Load	75% Load	100% Load				
DE250E0	50	250	SB	75.2	76	67.3	68.5	5.5	11654	61	143
	50	230	PP	75	75.8	67.1	68.1	5.5	11654	63	146
DE275E0	50	275	SB	75.5	76.3	67.7	68.9	5.5	11654	59	138
	50	250	PP	75.2	76	67.3	68.5	5.5	11654	61	143
DE275E3	50	275	SB	75	76.6	67.6	69.3	5.5	11654	60	140
	50	250	PP	74.7	76	67.1	68.7	5.5	11654	63	145
DE300E0	50	300	SB	75.7	76.6	68	69.3	5.5	11654	57	134
	50	275	PP	75.5	76.3	67.7	68.9	5.5	11654	59	138
DE300E3	50	300	SB	75.4	77.2	68.1	70	5.5	11654	57	135
	50	275	PP	75	76.6	67.6	69.3	5.5	11654	60	140
DE330E0	50	330	SB	76	76.9	68.4	69.7	5.5	11654	54	129
	50	300	PP	75.7	76.6	68	69.3	5.5	11654	57	134
DE330SE3	60	375	SB	79.7	81.3	72	74.2	6.7	14197	51	124
	60	338	PP	79.2	80.6	71.3	73.3	6.7	14197	55	131

Note: Sound level measurements are subject to instrumentation, installation and manufacturing variability, as well as ambient site conditions.

WEIGHTS & DIMENSIONS

A. Level 1

Model	Weight		Genset Overall Size (mm)		
	kg	lb	Length	Width	Height
DE250E0, DE275E0, DE250SE0	2447	5395	3988	1208	1779
DE300E3, DE300E0	3276	7222	3985	1410	2165
DE330E0	3396	7487	3985	1410	2165
DE275SE0, DE300SE0, DE300SE3	3276	7222	3988	1208	1779

B. Level 2

Model	Weight		Genset Overall Size (mm)		
	kg	lb	Length	Width	Height
DE250E0, DE275E0	2859	6303	3981	1410	2032
DE275E3, DE300E3, DE300E0	3404	7505	3981	1410	2032
DE330E0	3524	7769	3981	1410	2032
DE300SE0	3404	7769	3981	1410	2032

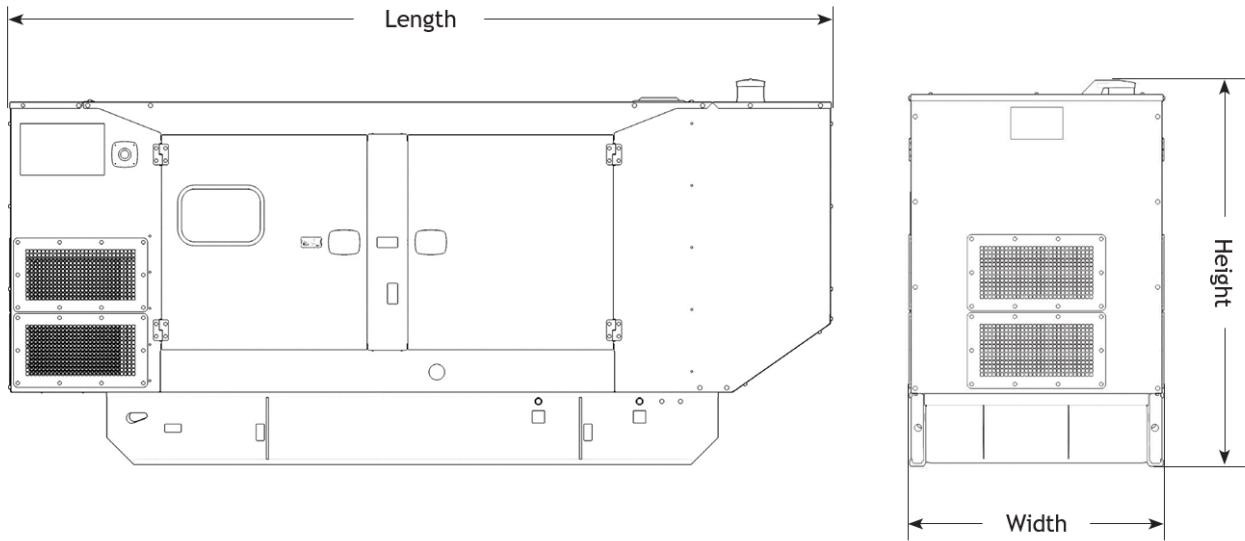



Image shown may not reflect actual configuration.

GCCP 1.3 – Control Panel

GCCP 1.3 Control Module is suitable for a wide variety of generator set applications. It controls operation of the generator, monitors an extensive number of engine parameters, and displays warnings, shutdown, and engine status information on the back-lit LCD screen, illuminated LEDs and remote PC, if desired

KEY FEATURES

- 4-line back-lit LCD text display
- Multiple display languages
- Five-key menu navigation
- LCD alarm indication
- Customisable power-up text and images
- Data logging facility
- Internal PLC editor
- Protections disable feature
- Fully configurable via PC using USB & RS485 communication
- Front panel configuration with PIN protection
- Power save mode
- 3-phase generator sensing and protection
- 3-phase mains (utility) sensing and protection (Optional)
- Automatic load transfer control (optional)
- Auto Mains (Utility) Failure capable (optional)
- Mains (utility) current and power monitoring (kW, kvar, kVA, pf) (Optional)
- Generator current and power monitoring (kW, kvar, kVA, pf)
- kW and kvar overload and reverse power alarms
- Over current protection
- Unbalanced load protection
- Breaker control via fascia buttons
- Fuel and start outputs configurable when using CAN
- Support for 0 V to 10 V & 4 mA to 20 mA sensors
- 8 configurable digital inputs (3 available for Customer use)
- 8 configurable digital outputs (5 available for Customer use)
- 4 configurable analogue outputs (3 available for Customer Use)
- CAN, MPU and alternator frequency speed sensing in one variant
- Real time clock
- Engine pre-heat and post-heat functions
- Engine run-time scheduler
- Engine idle control for starting & stopping
- Fuel usage monitor and low fuel level alarms
- 3 configurable maintenance alarms

BENEFITS

- Hours counter provides accurate information for monitoring and maintenance periods
- User-friendly set-up and button layout for ease of use
- Multiple parameters are monitored & displayed simultaneously for full visibility
- The module can be configured to suit a wide range of applications for user flexibility
- PLC editor allows user configurable functions to meet user specific application requirements.
- RS485 Communication port can be used for the Remote Monitoring Communication (Compatible with Cat PLG)

SPECIFICATION

DC SUPPLY

CONTINUOUS VOLTAGE RATING

8V to 35V Continuous
5V for upto 1 minute

CRANKING CROPOUTS

Able to survive 0V for 100mS, providing supply was at least 10V before dropout and supply recovers to 5V. This is achieved without the need for internal batteries.

LEDs and backlight will not be maintained during cranking.

MAXIMUM OPERATING CURRENT

260 mA at 12V, 150 mA at 24V

MAXIMUM STANDBY CURRENT

145 mA at 12V, 85 mA at 24V

CHARGE FAIL/EXCITATION RANGE

0V to 35V

GENERATOR & MAINS (UTILITY) VOLTAGE RANGE

15V to 415V AC (Ph to N)
26V to 719V AC (Ph to Ph)

FREQUENCY RANGE

3.5 Hz to 75 Hz

MAGNETIC PICKUP VOLTAGE RANGE

+/-0.5V TO 70V

FREQUENCY RANGE

10,000 Hz (max)

INPUTS

DIGITAL INPUTS A TO H

Negative switching

ANALOGUE INPUTS A & D

Configurable as:

Negative switching digital input 0V to 10V sensor
4 mA 20 mA sensor resistive sensor

ANALOGUE INPUTS B & C

Configurable as:

Negative switching digital input resistive sensor

OUTPUTS

OUTPUT A 7B (FUEL & START)

15A DC at supply voltage

AUXILIARY OUTPUTS C, D, E, F, G & H

2A DC at supply voltage

DIMENSIONS OVERALL

216 mm x 158 mm x 43 mm
8.5" x 6.2" x 1.5"

PANEL CUT-OUT

184 mm x 137 mm
7.2" x 5.3"

MAXIMUM PANEL THICKNESS

8 mm
0.3"

STORAGE TEMPERATURE RANGE

-40°C TO +85°C
-40°F TO 185°F

OPERATING TEMPERATURE RANGE

-30°C to +70°C
-22°F to +158°F

LET'S DO THE WORK.™

www.cat.com/electricpower

©2023 Caterpillar
All rights reserved.

Materials and specifications are subject to change without notice.

The International System of Units (SI) is used in this publication. CAT, CATERPILLAR, LET'S DO THE WORK, their respective logos, "Caterpillar Corporate Yellow", the "Power Edge" and Cat "Modern Hex" trade dress as well as corporate and product identity used herein, are trademarks of Caterpillar and may not be used without permission.