

Standby & Prime: 50 Hz



Image shown might not reflect actual configuration

Engine Model	Cat® C7.1 In-line 4-stroke Diesel
Bore x Stroke	105.0mm x 135.0mm (4.1in x 5.3 in)
Displacement	7.0 L (427.8 in³)
Compression Ratio	16.0:1
Aspiration	Turbocharged Air To Air Charge Cooled
Fuel Injection System	Inline
Governor	Mechanical

Model	Standby	Prime	Emission Strategy
DE200E0	50 Hz	50 Hz	Low BSFC
	200.0 kVA (160.0 kW)	180.0 kVA (144.0 kW)	

PACKAGE PERFORMANCE

Performance	Standby 50 Hz	Prime 50 Hz
Frequency	50 Hz	50 Hz
Genset Power Rating	200.0 kVA	180.0 kVA
Genset power rating with fan @ 0.8 power factor	160.0 kW	144.0 kW
Emissions	Low BSFC	
Performance Number	P4196A	P4196A
Fuel Consumption		
Fuel Tank Capacity, litres (US gal)	394 (104.1)	
100% load with fan, L/hr (gal/hr)	43.8 (11.6)	40.2 (10.6)
75% load with fan, L/hr (gal/hr)	34.2 (9.0)	30.9 (8.2)
50% load with fan, L/hr (gal/hr)	22.3 (5.9)	19.7 (5.2)
Cooling System¹		
Radiator air flow, m³/min (cfm)	307.2 (10849)	307.2 (10849)
Total coolant capacity, L (gal)	27.0 (7.1)	
Inlet Air		
Max. Combustion Air Intake Restriction, kPa (in H2O)	3.0 (12.0)	
Combustion air inlet flow rate, m³/min (cfm)	13.9 (490)	13.0 (457)
Max. Allowable Combustion Air Inlet Temp, °C (°F)	50 (122)	
Exhaust System		
Exhaust stack gas temperature, °C (°F)	538 (1000)	538 (1000)
Exhaust gas flow rate, m³/min (cfm)	33.9 (1195)	31.6 (1114)
Exhaust system backpressure (maximum allowable), kPa (in. water)	6.0 (1.8)	
Heat Rejection		
Heat rejection to jacket water, kW (Btu/min)	76.4 (4345)	74.2 (4220)
Heat rejection to alternator, kW (Btu/min)	13.2 (751)	13.2 (751)
Heat rejection to atmosphere from engine, kW (Btu/min)	25.6 (1456)	22.7 (1291)

Alternator ³	50 Hz		
Voltages	415V	400V	380V
Motor starting capability @ 30% Voltage Dip, skVA	328	307	280
Current, amps	278	288	303
Temperature Rise, °C	105/40		
Frame Size	M2294L4		

WEIGHTS & DIMENSIONS

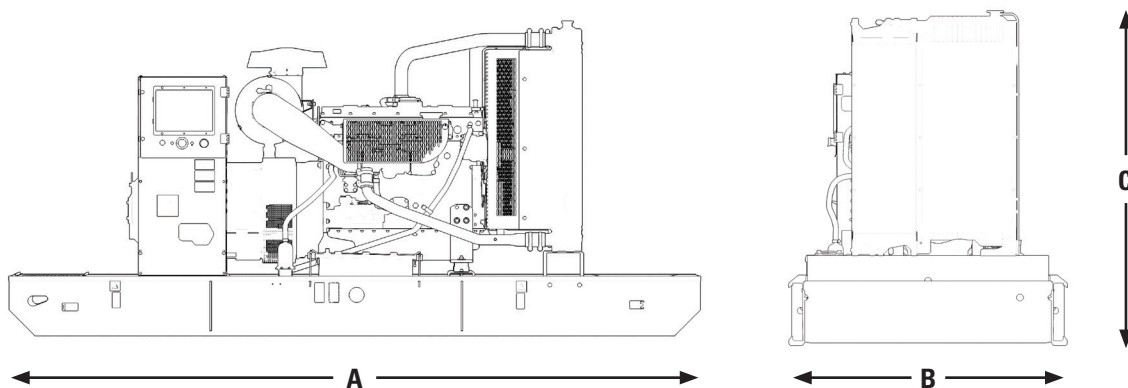

Note: General configuration not to be used for installation. See general dimension drawings for detail.

Dim "A" mm (in)	Dim "B" mm (in)	Dim "C" mm (in)	Dry Weight kg (lb)
2510 (98.8)	1010 (39.8)	1640 (64.6)	1532 (3377)

APPLICABLE CODES AND STANDARDS:

AS1359, CSA C22.2 No100-04, UL142, UL489, UL869, UL2200, NFPA37, NFPA70, NFPA99, NFPA110, IBC, IEC60034-1, ISO3046, ISO8528, NEMA MG1-22, NEMA MG1-33, 2006/95/EC, 2006/42/EC, 2004/108/EC.

Note: Codes may not be available in all model configurations. Please consult your local Cat Dealer representative for availability.

STANDBY: Output available with varying load for the duration of the interruption of the normal source power. Average power output is 70% of the standby power rating. Typical operation is 200 hours per year, with maximum expected usage of 500 hours per year.

PRIME: Output available with varying load for an unlimited time. Average power output is 70% of the prime power rating. Typical peak demand is 100% of prime rated kW with 10% overload capability for emergency use for a maximum of 1 hour in 12. Overload operation cannot exceed 25 hours per year

RATINGS: Ratings are based on SAE J1349 standard conditions. These ratings also apply at ISO3046 standard conditions.

DEFINITIONS AND CONDITIONS

¹ For ambient and altitude capabilities consult your Cat dealer. Air flow restriction (system) is added to existing restriction from factory.

² Emissions data measurement procedures are consistent with those described in EPA CFR 40 Part 89, Subpart D & E and ISO8178-1 for measuring HC, CO, PM, NOx. Data shown is based on steady state operating conditions of 77° F, 28.42 in HG and number 2 diesel fuel with 35° API and LHV of 18,390 BTU/lb. The nominal emissions data shown is subject to instrumentation, measurement, facility and engine to engine variations. Emissions data is based on 100% load and thus cannot be used to compare to EPA regulations which use values based on a weighted cycle.

³ UL 2200 Listed packages may have oversized generators with a different temperature rise and motor starting characteristics. Generator temperature rise is based on a 40° C ambient per NEMA MG1-32.

LET'S DO THE WORK.™