



# Cat<sup>®</sup> Tilt Rotate Systems

## MINI HYDRAULIC EXCAVATORS

Cat<sup>®</sup> Tilt Rotate Systems are an industry-first with fully integrated superior technology into your Next Generation 306 CR, 307.5, 308, 308.5, 309 or 310 Mini Hydraulic Excavator. Tiltrotators will help you get the job done faster with the quality you expect from Caterpillar. Tilt and rotate to reach at any angle without the need to reposition your machine. Tiltrotators are productive, easy-to-use, and provide a versatile solution to your operation.

### Features:

#### Applications

- Road Work and Railroads – Building angled dikes, trenches and drainage. Manipulating beams and poles or special tools for railroad repair.
- Earthmoving or General Construction – Grading, digging, trenching and pipe positioning, digging under square pipes, restoration or backfilling, landscape, foundation work, digging in corners.
- Maintenance – Sweeping, tree felling, pick and sort material.

#### Intuitive

- When compared to others, installation is also an industry-first with 100% integration in as little as 3 to 4 hours.
- Both the left and righthand joysticks control all machine and tiltrotator functionalities.
- Joysticks and display monitor work together.
- A single grease point provides grease to all joints requiring lubrication.
- Compatible with most grade control systems.

#### Versatile

- 360 degrees of continuous rotation and tilt up to 40 degrees left or right.
- From bucket to grapple from digging into front shovel mode.
- Capability to run hydro-mechanical tools, such as hammers, augers, cold planers, etc.
- Available with or without grapple.

#### Technology

- Fully integrated software.
- Automatically spread material evenly and quickly with the Bucket Shake function.
- Return the tiltrotator to a user-defined position with the press of a button using the Home function.
- Triangular movement control lets you tilt, rotate and use auxiliary hydraulics.
- Reliable locking control system provides audible signals and visual in-cab indicators to confirm the bottom coupler is engaged.
- Optional positioning software informs operator of attachment's position by standard equipped monitoring sensors.

# Cat® Tilt Rotate Systems

## Compatibility

Model	Machines
TRS6	306 CR
TRS8	307.5, 308, 309, 310

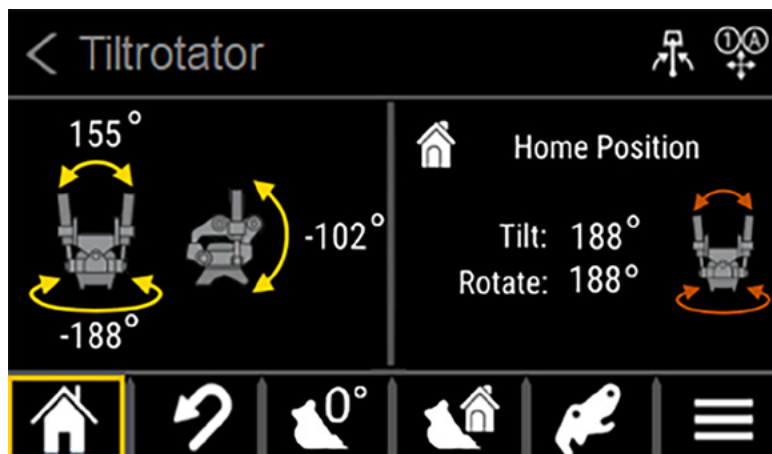
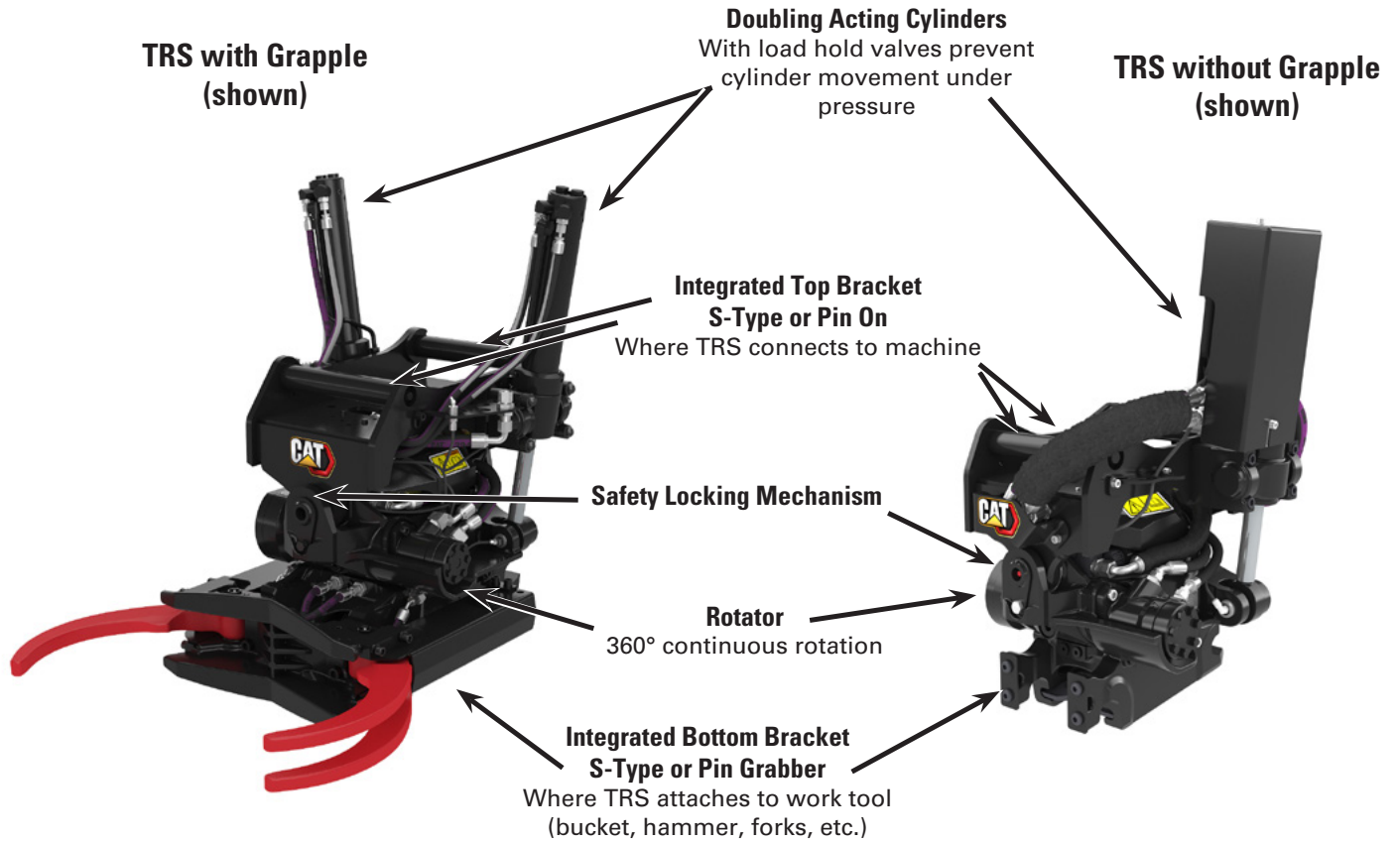

**Integrated Machine Display Screens**  
TRS Tilt, Rotation, Curl Position

## Specifications

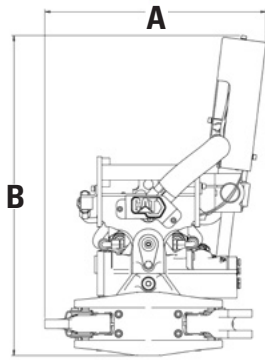

**TRS6 with Grapple**

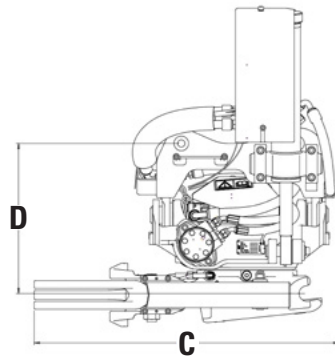

**TRS6 without Grapple**

Model	TRS6		
	with Grapple	without Grapple	
Top Interface	S-Type or Pin On		
Bottom Interface	S-Type		
<b>A</b> Width	mm (in)	574 (22.6)	490 (19.3)
<b>B</b> Height	mm (in)	819 (32.2)	819 (32.2)
<b>C</b> Length	mm (in)	609 (24)	526 (20.7)
<b>D</b> Pin to Pin Distance	mm (in)	S-Type – 389 (15.3) Pin On – 419 (16.5)	S-Type – 389 (15.3) Pin On – 419 (16.5)
Weight	kg (lb)	245 (540)	210 (463)
Machine Class		6 Ton	
Standard Bucket Size	m <sup>3</sup> (ft <sup>3</sup> )	0.25 (8.8)	
Maximum Bucket Width	mm (in)	1200 (47)	
Maximum Break Out Force	kN (lbf)	50 (11,240)	
Tilt Angle (Left / Right)		40 degrees	
Rotation Speed – 7sec for 1 Full Rotation at flow		30 L/min (8 gpm)	
Working Pressure	kPa (psi)	25 000 (3,626)	
Optimal Hydraulic Flow	L/min (gpm)	45-80 (12-21)	
Lubrication Points		1	
Turning Torque		3900 N-m at 25 000 kPa 2,876 lb-ft at 3,626 psi	
Tilting Torque	kN-m (lb-ft)	14.4 (10,627)	

# Cat® Tilt Rotate Systems

## Specifications

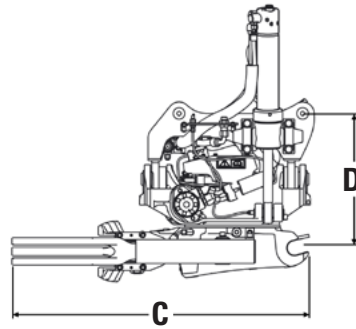
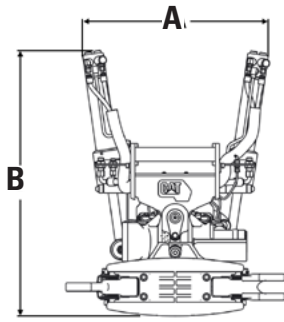

TRS8 with Grapple

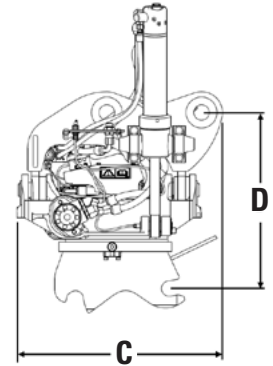
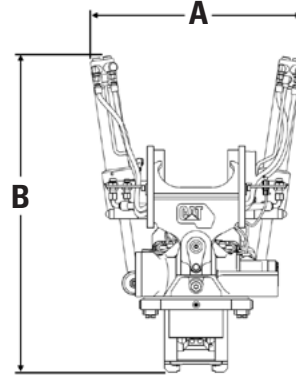

TRS8 without Grapple

Model	TRS8				
	with Grapple		without Grapple		
Top Interface	S-Type		S-Type	Pin On	Pin On
Bottom Interface	S-Type		S-Type	Pin Grabber	Pin Grabber
<b>A</b> Width	mm (in)	678 (26.4)	678 (26.4)	678 (26.4)	678 (26.4)
<b>B</b> Height	mm (in)	958 (37.7)	945 (37.2)	1001 (39.4)	1044 (41.1)
<b>C</b> Length	mm (in)	1053 (41.5)	608 (23.9)	665 (26.2)	665 (26.2)
<b>D</b> Pin to Pin Distance	mm (in)	467 (18.4)	467 (18.4)	570 (22.4)	594 (23.4)
Machine Class		7 – 10 Ton	7 – 10 Ton	8 Ton	10 Ton
Weight	kg (lb)	360 (764)	310 (683)	310 (683)	310 (683)
Standard Bucket Size	m <sup>3</sup> (ft <sup>3</sup> )	0.5 (17.7)			
Maximum Bucket Width	mm (in)	1500 (59)			
Maximum Break Out Force	kN (lbf)	78 (17,535)			
Tilt Angle (Left / Right)		40 degrees			
Rotation Speed – 7sec for 1 Full Rotation at flow		50 L/min (13 gpm)			
Working Pressure	kPa (psi)	25 000 (3,626)			
Optimal Hydraulic Flow	L/min (gpm)	45-75 (12-20)			
Lubrication Points		1			
Turning Torque		6600 N-m at 25 000 kPa 4,868 lb-ft at 3,626 psi			
Tilting Torque	kN-m (lb-ft)	26.5 (19,545)			

For more complete information on Cat products, dealer services, and industry solutions, visit us on the web at [www.cat.com](http://www.cat.com)

AEHQ8295 (06-2020)  
(Global)

© 2020 Caterpillar  
All rights reserved

Materials and specifications are subject to change without notice. Featured machines in photos may include additional equipment. See your Cat dealer for available options.

CAT, CATERPILLAR, LET'S DO THE WORK, their respective logos, "Caterpillar Corporate Yellow," the "Power Edge" and Cat "Modern Hex" trade dress as well as corporate and product identity used herein, are trademarks of Caterpillar and may not be used without permission.

