

# 4016-61TRG Electric Power Engines

**Power range 1500 rpm 1269-2183 kWm** (engine gross power)

**Emissions Fuel optimised**

The Perkins® 4000 Series family of 6, 8, 12 and 16 cylinder diesel engines was designed in advance of today's uncompromising demands within the power generation industry and includes superior performance and reliability.

The 4016-61TRG are turbocharged, air-to-water chargecooled, 16 cylinder diesel engines.

Its premium design and specification features provide economic and durable operation as well as exceptional power to weight ratio, improved serviceability, low gaseous emissions, overall performance and reliability essential to the power generation market. The 4016-61TRG are specially tuned for improved load acceptance response in standby duty.

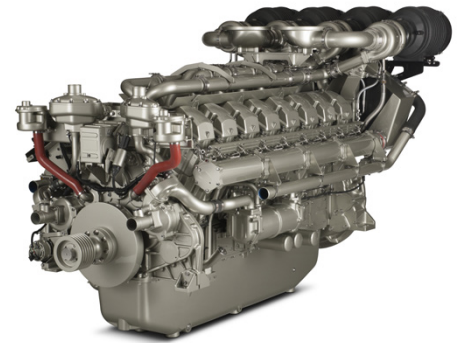

## Features and benefits

- Individual 4 valve cylinder heads giving optimised gas flows and unit fuel injectors ensure ultra fine fuel atomisation and hence controlled rapid combustion **maximising productivity**.
- Commonality of components with other engines in the 4000 Series family for reduced stocking levels and **ease of integration**.
- Designed to provide **low cost of ownership**, simple maintenance and reduced downtime.
- Perkins engines are designed and developed with our customer in mind. Keeping service cost to a minimum ensures **low periodic running costs**. This is achieved through 500 hour service intervals for oil and fuel as standard under all operating conditions.
- The **long productive life** of our products is supported through the Perkins 12 month warranty as standard for prime power applications. For further peace of mind, there is also the option to purchase Extended Service Contracts through **Perkins Platinum Protection**. Contact your local distributor or visit [www.perkins.com/en\\_GB/aftermarket/perkins-platinum-protection](http://www.perkins.com/en_GB/aftermarket/perkins-platinum-protection).
- Perkins takes pride in manufacturing all products globally to the same **high quality standard**. All of our products are manufactured in world class facilities to ensure highest quality for your peace of mind.

# 4016-61TRG Electric Power Engines

**Power range 1500 rpm 1269-2183 kWm** (engine gross power)

**Emissions Fuel optimised**

## Specification

	Model		
	4016-61TRG1	4016-61TRG2	4016-61TRG3
Configuration	ElectropaK		
Cylinders	16 60° vee		
Displacement, litres (in <sup>3</sup> )	61.1 (3722)		
Aspiration	Quad turbocharged, air-to-water chargecooled		
Bore and stroke, mm (in)	160 x 190 (6.3 x 7.5)		
Combustion system	Direct injection		
Compression ratio	13:1		
Exhaust aftertreatment	N/A		
Rotation (viewed from flywheel)	Anti-clockwise, viewed from flywheel end		
Total lubricating oil capacity, litres (US gal)	237 (63)		
Cooling system	Watercooled		
Total coolant capacity, litres (US gal)	270 (71)		

## Technical information

Model	Speed rpm	Type of Operation	Engine Power		Typical Generator Output* (Net)		Prime Fuel Consumption				
			Gross	Net			110%	100%	Baseload	75%	50%
			kWm (hp)	kWm (hp)	kVA	kWe	g/kWh	g/kWh	g/kWh	g/kWh	g/kWh
4016-61TRG1	1500	Baseload	1269 (1700)	1179 (1579)	1400	1120	195	194	192	192	186
		Prime	1648 (2208)	1558 (2088)	1850	1480					
		Standby	1774 (2377)	1684 (2257)	2000	1600					
4016-61TRG2	1500	Baseload	1437 (1926)	1347 (1805)	1600	1280	201	197	195	195	192
		Prime	1774 (2377)	1684 (2257)	2000	1600					
		Standby	1985 (2659)	1895 (2538)	2250	1800					
4016-61TRG3	1500	Baseload	1600 (2144)	1500 (2010)	1800	1440	209	205	200	200	204
		Prime	1975 (2647)	1875 (2513)	2250	1800					
		Standby	2183 (2925)	2083 (2791)	2500	2000					

\*Generator powers are typical and based on typical alternator efficiencies and a power factor (cos  $\theta$ ) or 0.8.

# 4016-61TRG Electric Power Engines

**Power range 1500 rpm 1269-2183 kWm** (engine gross power)

**Emissions**

**Fuel optimised**

## Standard equipment

	Model		
	4016-61TRG1	4016-61TRG2	4016-61TRG3
Electro unit or electropaK	ElectropaK	ElectropaK	ElectropaK
Radiator fitted	✓	✓	✓
Fuel filter, engine mounted	✓	✓	✓
Water separator	✓	✓	✓
Fuel priming pump (manual/electric)	Manual	Manual	Manual
Fuel cooler	✓	✓	✓
Air filter, engine mounted	✓	✓	✓
Engine ECM, engine mounted	N/A	N/A	N/A
Wiring harness to ECM	N/A	N/A	N/A
Wiring harness (all connectors to single customer interface)	N/A	N/A	N/A
Starter motor	✓	✓	✓
Battery charging alternator	✓	✓	✓
Flywheel housing	✓	✓	✓
Flywheel	✓	✓	✓
Fan	✓	✓	✓
Fan guard	✓	✓	✓
Temp and oil pressure for automatic stop/alarm configurable	✓	✓	✓

Photographs are for illustrative purposes only and may not reflect final specification.  
 All information in this document is substantially correct at time of printing and may be altered subsequently.  
 Final weight and dimensions will depend on completed specification.  
 Information subject to selected configuration, and subject to change without notice.

# 4016-61TRG Electric Power Engines

**Power range 1500 rpm 1269-2183 kWm (engine gross power)**

**Emissions Fuel optimised**

## Engine package weights and dimensions

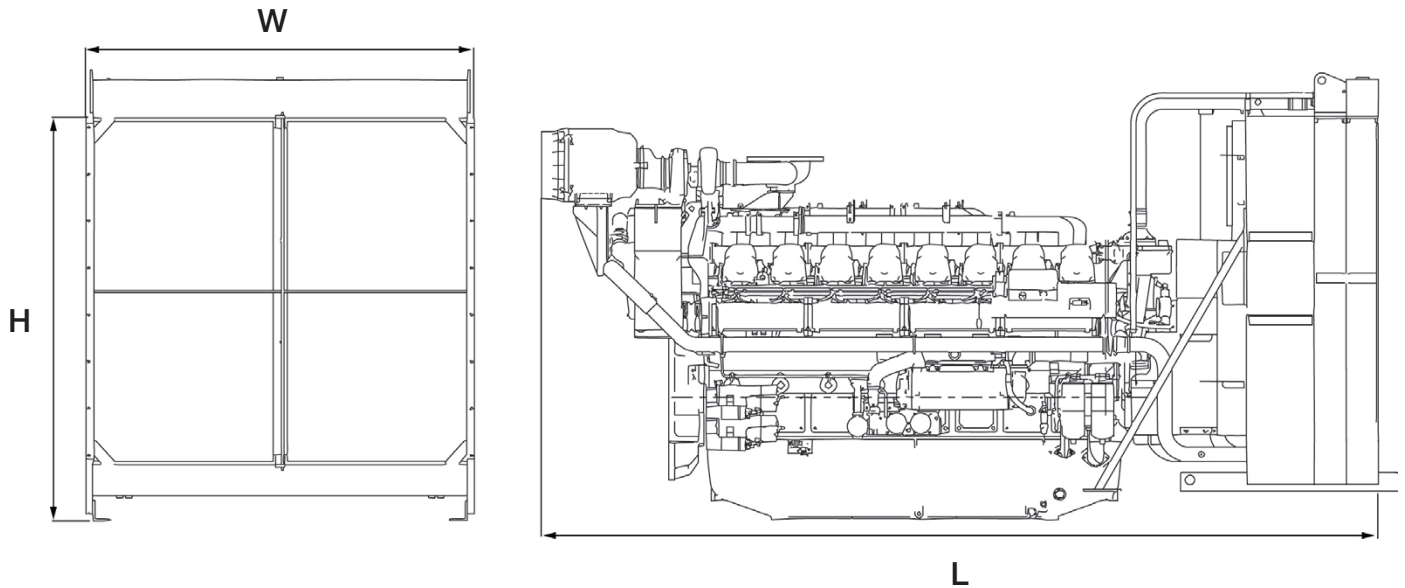

	Model		
	4016-61TRG1	4016-61TRG2	4016-61TRG3
Configuration	ElectropaK	ElectropaK	ElectropaK
Temperate dimensions, H x L x W, mm (in)	2128 x 3302 x 1723 (84 x 130 x 68)	2366 x 4542 x 2185 (93 x 179 x 86)	3175 x 4542 x 2185 (125 x 179 x 86)
Temperate dry weight, kg (lb)	5570 (12280)		
Tropical dimensions, H x L x W, mm (in)	2128 x 3302 x 1723 (84 x 130 x 68)	3175 x 4542 x 2185 (125 x 179 x 86)	3736 x 4562 x 2185 (147 x 180 x 86)
Tropical dry weight, kg (lb)	5570 (12280)		

Baseload power: Power available for continuous full load operation. No overload is permitted.

Prime power: Power available at variable load in lieu of a main power network. Overload of 10% is permitted for 1 hour in every 12 hours of operation.

Standby (maximum): Power available at variable load in the event of a main power network failure. No overload is permitted.

Photographs are for illustrative purposes only and may not reflect final specification.  
 All information in this document is substantially correct at time of printing and may be altered subsequently.  
 Final weight and dimensions will depend on completed specification.  
 Information subject to selected configuration, and subject to change without notice.