



# Cat<sup>®</sup> 415 IL

## INDUSTRIAL LOADER

The Cat<sup>®</sup> 415 IL Industrial Loader delivers great performance, improved fuel efficiency, and a superior hydraulic system. The 415 IL features the following:

- **Ergonomic Operator Station** – Ample legroom inside the cab makes rotating the seat simple. The Adjustable Mechanical Suspension seat provides comfort to the operator while loading.
- **Complete Machine Control** – The Cat Industrial Loader offers dual differential lock control. In adverse conditions, the operator has the option of engaging the differential lock from the floor mounted pedal or by using the push button on the loader joystick.
- **Superior Blade Controls** – The Cat Industrial Loader offers finger lever pilot controls that require less operator effort. The 415 IL comes standard with a five function hydraulic valve for increased versatility.
- **Machine Performance** – The proven Cat C3.6 engine delivers solid performance, meets U.S. EPA Tier 4 Final/EU Stage V emission standards, and requires no diesel exhaust fluid (DEF).
- **Machine Versatility** – The all new Integrated Tool Carrier (IT Coupler) for Single Tilt Loader Arm configurations are available from the factory or for simple field installation. The Cat Industrial Loader with Integrated Tool Carrier (IT Coupler) will be the most versatile machine on the job site providing quick connection to a variety of Cat Attachments.
- **Cat Attachments** – A large portfolio of Attachments, including but not limited to assorted Buckets, Brooms, Snow Pushes and Brooms are for field installation.

## Specifications

### Engine

Engine Model	Cat C3.6	
Gross Power		
SAE J1995	56 kW	75 hp
ISO 14396	55 kW	74 hp
Rated Net Power @ 2,200 rpm		
SAE J1349	52 kW	69 hp
ISO 9249	51 kW	69 hp
Net Peak Power @ 2,200 rpm		
SAE J1349	52 kW	69 hp
ISO 9249	51 kW	69 hp
Bore	98 mm	3.86 in
Stroke	120 mm	4.72 in
Displacement	3.6 L	220 in <sup>3</sup>
Net Torque Rise @ 1,200 rpm	86%	
Net Peak Torque SAE J1349	418 N·m	308 lbf-ft

- Engine meets U.S. EPA Tier 4 Final emission standards.
- No derating required up to 2286 m (7,500 ft).

### Weights\*

Operating Weight		
Minimum	6366 kg	14,035 lb
Maximum (ROPS Capacity)	8000 kg	17,637 lb
Cab, ROPS/FOPS	163 kg	359 lb
Air Conditioning	46 kg	101 lb
MP Bucket (0.96 m <sup>3</sup> /1.25 yd <sup>3</sup> )		
With Fold-over Forks	915 kg	2,017 lb
Without Fold-over Forks	745 kg	1,642 lb
Front Counterweight		
Counterweights (Option 1)	115 kg	255 lb
Counterweights (Option 2)	240 kg	530 lb
Counterweights (Option 3)	460 kg	1,015 lb
Rear Counterweight	90 kg	198 lb

\*Specifications shown are for machine equipped with 0.76 m<sup>3</sup> (1.0 yd<sup>3</sup>) general purpose loader bucket, 115 kg (255 lb) front counterweight, 80 kg (176 lb) operator, all wheel drive and full fuel tank.



# 415 IL Industrial Loader

## Transmission

### Power Shuttle Transmission – Standard

Forward – 1st	5.4 km/h	3.4 mph
2nd	8.9 km/h	5.5 mph
3rd	20 km/h	13 mph
4th	36 km/h	23 mph
Reverse – 1st	5.4 km/h	3.4 mph
2nd	8.9 km/h	5.5 mph
3rd	20 km/h	13 mph
4th	36 km/h	23 mph

## Axle Ratings

### Front Axle, 4WD

Static	12 000 kg	26,455 lb
Dynamic	6000 kg	13,228 lb

### Rear Axle

Static	22 964 kg	50,582 lb
Dynamic	9186 kg	20,233 lb

## Hydraulic System

Type	Closed Center	
Pump Type	Variable Flow, Axial Piston	
Pump Capacity @ 2,200 rpm	125 L/min	33.0 gal/min
System Pressure – Hitch/Box Scraper	20 500 kPa	2,973 psi
System Pressure – Loader	20 500 kPa	2,973 psi

## Steering

Type	Front Wheel	
Power Steering	Hydrostatic	
Bore	65 mm	2.6 in
Stroke	106 mm	4.2 in
Rod Diameter	40 mm	1.6 in
Axle Oscillation	11°	
Turning Circle – 2WD/4WD (inner wheel not braked)		
Outside, Front Wheels	8.18 m	26'10"
Outside, Widest Loading Bucket	10.97 m	36'0"

## Service Refill Capacities

Cooling System with Air Conditioning	16.5 L	4.4 gal
Fuel Tank	160 L	42 gal
Engine Oil with Filter	8.8 L	2.3 gal
Transmission – Power Shuttle		
2WD	15 L	4.0 gal
4WD	15 L	4.0 gal
Rear Axle	16.5 L	4.4 gal
Planetaries	1.7 L	0.4 gal
Front Axle (4WD)	11.0 L	2.9 gal
Planetaries	0.7 L	0.2 gal
Hydraulic System	90.0 L	23.8 gal
Hydraulic Tank	40 L	10.6 gal

- Requires ultra-low sulfur fuel  $\leq$  15 ppm fuel sulfur

## Tires

Standard configuration of front/rear tires:

- Front: 12.5 80/16.9; Rear: 16.9-24

## Counterweights – Front

(minimum counterweight recommendations)

### Standard Stick

Loader Bucket	Power Train		
GP	4WD	116 kg	255 lb
MP	4WD	no counterweight	

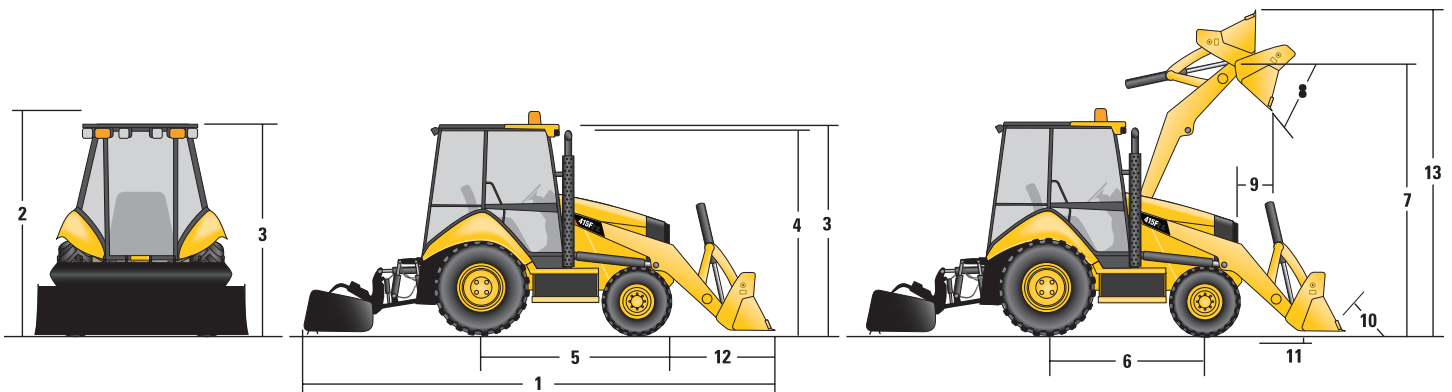

## Dimensions

	Single Tilt Loader							
	0.76 m <sup>3</sup> (1.0 yd <sup>3</sup> ) GP Bucket		0.96 m <sup>3</sup> (1.25 yd <sup>3</sup> ) GP Bucket		1.0 m <sup>3</sup> (1.31 yd <sup>3</sup> ) MP Bucket		1.0 m <sup>3</sup> (1.31 yd <sup>3</sup> ) MP Bucket with Forks	
<b>1</b> Overall Length (Loader on Ground) – with Box Blade	6256 mm	20'6"	6368 mm	20'11"	6286 mm	20'7"	6286 mm	20'7"
Overall Length (Loader on Ground) – Hitch Only	5146 mm	16'11"	5259 mm	17'3"	5177 mm	17'0"	5177 mm	17'0"
Overall Transport Length – with Box Blade	6314 mm	20'9"	6397 mm	21'0"	6360 mm	20'10"	6360 mm	20'10"
Overall Transport Length – Hitch Only	5158 mm	16'11"	5241 mm	17'2"	5205 mm	17'1"	5205 mm	17'1"
<b>2</b> Overall Transport Height	3577 mm	11'9"	3577 mm	11'9"	3577 mm	11'9"	3577 mm	11'9"
Overall Width	2322 mm	7'7"	2322 mm	7'7"	2322 mm	7'7"	2322 mm	7'7"
<b>3</b> Height to Top of Cab/Canopy	2819 mm	9'3"	2819 mm	9'3"	2819 mm	9'3"	2819 mm	9'3"
<b>4</b> Height to Top of Exhaust Stack	2744 mm	9'0"	2744 mm	9'0"	2744 mm	9'0"	2744 mm	9'0"
Height to Loader Hinge Pin (transport)	381 mm	1'3"	381 mm	1'3"	432 mm	1'5"	432 mm	1'5"
Ground Clearance (left hand step)	294 mm	1'0"	294 mm	1'0"	294 mm	1'0"	294 mm	1'0"
Ground Clearance (AWD guard)	294 mm	1'0"	294 mm	1'0"	294 mm	1'0"	294 mm	1'0"
Ground Clearance (460 kg/1,015 lb counterweight)	274 mm	0'11"	274 mm	0'11"	274 mm	0'11"	274 mm	0'11"
<b>5</b> Rear Axle Centerline to Front Grill	2705 mm	8'10"	2705 mm	8'10"	2705 mm	8'10"	2705 mm	8'10"
Front Wheel Tread Gauge	1895 mm	6'3"	1895 mm	6'3"	1895 mm	6'3"	1895 mm	6'3"
Rear Wheel Tread Gauge	1714 mm	5'7"	1714 mm	5'7"	1714 mm	5'7"	1714 mm	5'7"
<b>6</b> Wheelbase 4WD	2200 mm	7'3"	2200 mm	7'3"	2200 mm	7'3"	2200 mm	7'3"

## Loader Bucket Dimensions and Performance

	Single Tilt Loader							
	0.76 m <sup>3</sup> (1.0 yd <sup>3</sup> ) GP Bucket		0.96 m <sup>3</sup> (1.25 yd <sup>3</sup> ) GP Bucket		1.0 m <sup>3</sup> (1.31 yd <sup>3</sup> ) MP Bucket		1.0 m <sup>3</sup> (1.31 yd <sup>3</sup> ) MP Bucket with Forks	
Capacity (SAE Rated)	0.76 m <sup>3</sup>	1.0 yd <sup>3</sup>	0.96 m <sup>3</sup>	1.25 yd <sup>3</sup>	1.0 m <sup>3</sup>	1.31 yd <sup>3</sup>	1.0 m <sup>3</sup>	1.31 yd <sup>3</sup>
Overall Bucket Width	2262 mm	89 in	2262 mm	89 in	2279 mm	90 in	2279 mm	90 in
Lift Capacity at Maximum Height	2660 kg	5,864 lb	2566 kg	5,657 lb	2363 kg	5,209 lb	2248 kg	4,955 lb
Breakout Force	42 076 N	9,459 lbf	39 722 N	8,929 lbf	38 609 N	8,679 lbf	37 120 N	8,345 lbf
Tipping Load at Breakout Point	5496 kg	12,117 lb	5103 kg	11,250 lb	5116 kg	11,279 lb	4974 kg	10,965 lb
<b>7</b> Maximum Hinge Pin Height	3474 mm	11'5"	3474 mm	11'5"	3474 mm	11'5"	3474 mm	11'5"
<b>8</b> Dump Angle at Full Height	44°		44°		44°		44°	
Dump Height at Maximum Angle	2824 mm	9'3"	2746 mm	9'0"	2798 mm	9'2"	2798 mm	9'2"
<b>9</b> Dump Reach at Maximum Angle	733 mm	2'5"	814 mm	2'8"	722 mm	2'4"	722 mm	2'4"
<b>10</b> Maximum Bucket Rollback at Ground Level	37°		37°		38°		38°	
<b>11</b> Digging Depth	83 mm	3"	83 mm	3"	110 mm	4"	110 mm	4"
Maximum Grading Angle	116°		112°		116°		116°	
Width of Dozer Cutting Edge	N/A		N/A		2262 mm	7'5"	2262 mm	7'5"
<b>12</b> Grill to Bucket Cutting Edge, Carry Position	1405 mm	4'7"	1488 mm	4'11"	1451 mm	4'9"	1451 mm	4'9"
<b>13</b> Maximum Operating Height	4206 mm	13'10"	4355 mm	14'3"	4404 mm	14'5"	4878 mm	16'0"
Jaw Opening Maximum	N/A		N/A		790 mm	2'7"	790 mm	2'7"
Bucket Jaw Clamping Force	N/A		N/A		50 600 N	11,375 lbf	50 600 N	11,375 lbf
Weight (does not include teeth or forks)	384 kg	847 lb	451 kg	994 lb	745 kg	1,642 lb	915 kg	2,017 lb

Dimensions and performance specifications shown are for machines equipped with 12.5/80-18 front tires, 16.9L-24 rear tires, ROPS canopy, 0.76 m<sup>3</sup> (1.00 yd<sup>3</sup>) loader bucket and standard equipment unless otherwise specified.

# 415 IL Industrial Loader

## STANDARD EQUIPMENT

- Air cleaner
- Alarm, back-up
- Audible system fault alarm
- Box Blade Controls, finger lever pilot
- Battery, maintenance-free, 880 CCA
- Battery disconnect switch
- Brace, lift cylinder
- Brake, secondary parking
- Brakes, hydraulically boosted, oil disc, dual pedals, interlocking
- Bucket level indicator
- Canopy, ROPS/FOPS
- Coat restraint
- Coolant/antifreeze, extended life
- Counterweight, bumper
- Dome light (cab only)
- Diagnostic port for engine
- Differential lock, floor mounted
- Differential lock, loader joystick
- Drink holders, two
- Engine, Cat C3.6, meets Tier 4 Final emission standards, diesel particulate filter
- Engine enclosure, sound suppression removal panels
- Face seals, O-ring
- Fan, suction and guard
- Fast reversing shuttle, all gears
- Fenders, rear
- Filters, spin-on: fuel, engine oil, transmission oil, water separator
- Filters, bowl and cartridge: hydraulic fluid
- Flashing hazards/signal lights
- Floor mat
- Fuel tank, fully enclosed
- Fully hinged front grill for cooling package cleaning access
- Gauge cluster: coolant temperature, fuel level, torque converter temperature, battery voltage
- Ground level fuel fill
- High ambient cooling package
- Hitch, rear 3-point
- Hood lock, inside cab
- Hydraulic hose, Cat XT™-3
- Hydraulic oil cooler
- Hydraulic oil level sight gauge
- Hydraulic valve, hydrostatic steering
- Hydraulic valves, loader 3 function
- Hydraulic valves, rear 5 function
- Hydraulics, load sensing with variable displacement piston pump
- Indicator lights and LCD warnings for system status
- Instrument panel lights
- Key start/stop system
- LCD screen with machine system information
- Lights, working (2 front, 2 rear)
- Loader, self-leveling, return-to-dig and transmission disconnect switch
- Loader, single tilt
- Mirror, rearview
- Open circuit breather
- Power receptacle, 12 volt, 2 internal, 2 external roof mounted
- Power steering, hydrostatic
- Seat belt, retractable, 75 mm (3 in)
- Steering knob
- Seat, mechanical suspension, fabric or vinyl cover, with armrest
- Starting system, glow plugs
- Steering, hydrostatic
- Storage compartment, lockable
- Storage tray
- Stop and tail lights
- Tires, 12.5/80-18 front, 16.9-24 rear
- Toolbox, external, lockable
- Torque converter
- Throttle, foot, electronic
- Transmission, four speed, synchromesh
- Transmission neutralizer switch
- Transport tie-downs
- Four Wheel Drive
- Warning horn, electric
- Product Link™, cellular, PLE643
- Product Link, dual mode, PLE683

## OPTIONAL EQUIPMENT

- Battery, additional, 880 CCA
- Box, blade/scarifier
- Cab, standard with air conditioning
- Cold weather fuel (-30° C/-22° F)
- Cold weather package, including additional battery, engine block heater, radiator antifreeze (-50° C/-58° F), cold weather fuel (-30° C/-22° F) and mounting for an ether bottle
- Counterweights, 115 kg (255 lb), 240 kg (530 lb) or 460 kg (1,015 lb)
- Counterweight, rear 90 kg (198 lb)
- Dual tilt rear hitch
- Face fan
- Fenders, front with integral steps
- Radio and CD player, Bluetooth
- Ride Control
- Rotating beacon, magnetic mount
- Security system keypad
- Vandalism protection, gauge cover
- Work Tool Attachments such as buckets, forks, and material handling arms. See your Cat dealer for more information.
- LED lights, working (2 front, 2 rear)
- Security system, Bluetooth®
- Security System, operator display
- Side mirrors, cab, external
- Single Tilt Loader Coupler, Integrated Tool Carrier (IT) Interface

For more complete information on Cat products, dealer services, and industry solutions, visit us on the web at [www.cat.com](http://www.cat.com)

© 2020 Caterpillar  
All rights reserved

Materials and specifications are subject to change without notice. Featured machines in photos may include additional equipment. See your Cat dealer for available options.

CAT, CATERPILLAR, LET'S DO THE WORK, their respective logos, "Caterpillar Corporate Yellow," the "Power Edge" and Cat "Modern Hex" trade dress as well as corporate and product identity used herein, are trademarks of Caterpillar and may not be used without permission.

AEHQ8266 (04-2020)  
Build Number: 07A  
(Am N)

