



Cat[®] PM310

Cold Planer

The Cat[®] PM310 cold planer delivers efficient production and advanced cutting capabilities, with Cat GRADE with Grade and Slope technology to increase cutting precision. Simple controls and an improved operator work environment make operation comfortable, while long service intervals and easy access to critical components simplifies service. Many options are available to enhance machine versatility when optimum maneuverability or high production capabilities are required.

Not all features available in all regions. Consult your Cat dealer for specific configurations available in your region.

Efficient Performance

- Cat[®] C9.3 engine meets regional emission standards
- Smooth and efficient operation with Automatic Idle Control and multiple rotor speeds optimize output and demand on the engine
- High capacity cooling system keeps engine at ideal temperatures for optimal fuel efficiency and lower emissions
- Automatic load sensing on the rotor adjusts milling speed to prevent stalls and optimize production

Optimal Maneuverability and Control

- Robust propel system features dual displacement planetary motors at each leg post, utilizing a cross-drive pattern for additional traction in straight cuts
- Automatic traction control maintains consistent speed in the most challenging applications
- Articulating right rear leg maximizes stability and traction in demanding cuts while enhancing flush cutting capability when needed
- Optional ballast weight kit available to increase productivity in specific applications
- Wheel or track undercarriage options offer a balance of traction, speed and maneuverability
- Reliable track undercarriage option leverages proven designs from Cat dozers and an automatic tensioning system to ensure consistent performance and longer track life
- Ability to electronically switch between rotor speeds during operation

Comfortable Work Environment

- Operate in comfort with a standard suspension seat, adjustable right arm console and intuitive, ergonomic controls
- A sliding operator station extends up to 215 mm (8.5 in) to provide improved visibility to the cutting edge
- Work day or night with backlit keypads and well-lit work areas
- Touchscreen displays provide access to gauge cluster, operating information, remote camera feeds, machine controls and diagnostics
- Optional remote cameras enhance visibility to the cutting edges, conveyor, and rear of the machine
- Cut closer to obstacles on the right side using an optional remote camera above the cutter box with an adjustable on-screen guidance line
- Optional windscreens can be added for increased comfort
- Maximize dust removal from the working areas with the optional dust abatement system



Cat® PM310 Cold Planer

Durable and Dependable Cutting System

- The rotor drive system features a heavy-duty dry clutch, dual stage belt drive and automatic belt-tensioning to prevent slippage
- Reinforced cutting chamber offers enhanced durability
- Hardened full length side plate skis and anti-slab shoes reduce wear and maintenance

Boost Precision with Integrated Cat Technology

- Achieve accurate, repeatable and automatic cutting precision with the integrated Cat GRADE with Grade and Slope system
- The optional grade control box can be positioned in the operator station or on the back of the machine to enable interaction with the grade system from the ground level
- Obtain full control of grade and slope from any control box
- Seamlessly switch between multiple grade sensors for uninterrupted accuracy during milling
- Adjust the speed at which the rotor drops into the cut for optimal machine control
- Set and automate transitions in/out of cuts and save settings for future jobs
- Clear obstacles in the cutting path with ease using the obstacle jump feature
- Enhance for full 3D milling operation (additional hardware required)

High Production System K Rotors Optimize Cutting Capability

- Cat System K rotors feature efficient material flow with an excellent cutting pattern for numerous applications
- A tapered dual-retention design secures toolholders in place without a retaining pin, bolt or setscrew, speeding up replacement and eliminating the need for fasteners or torquing
- Reversible paddles and high strength alloys reduce wear and abrasion to extend rotor life
- Optional diamond bits can extend replacement intervals up to 80 times longer than conventional carbide bits

Simplified Service

- Maintenance is easier with large service doors for access to critical components
- Maintenance-free track components and easy to replace track pads lower service costs
- Standard ground-level controls and an optional hydraulically-operated rotor turning device simplify bit removal and replacement
- Operate select machine functions during maintenance and service with the accessory drive system
- Electrical system wiring is color-coded and numbered for easy identification and wrapped in a protective, abrasion-resistant nylon braid for longer life
- Extended hydraulic oil service intervals: 3000 hours without oil sampling, 6000 hours with oil sampling
- Track scheduled maintenance with Cat Product Link™ telematics services
- Electronic Control Modules (ECMs) monitor machine systems to alert the operator of performance issues and can be paired with Product Link options to enable additional remote services with your local Cat dealer
- Multi-piece, cartridge-style engine filters are environmentally friendly, reducing waste and lowering replacement costs
- Convenient parts availability, dealer locations and service repair kits simplify ordering of high wear components

Standard and Optional Equipment

Standard and optional equipment may vary. Consult your Cat dealer for details.

	Standard	Optional		Standard	Optional
OPERATOR ENVIRONMENT			POWERTRAIN		
Sliding operator station	✓		Auto engine idle control	✓	
Suspension seat	✓		High capacity cooling system	✓	
Ground control keypad	✓		Automatic load control	✓	
Single high-resolution LCD touchscreen display	✓		Wheel undercarriage	✓	
12-volt power receptacle	✓		Track undercarriage		✓
Additional high-resolution LCD touchscreen display		✓	CE certificate		✓
Powered canopy		✓	HYDRAULIC SYSTEM		
Windscreens		✓	Traction control	✓	
Remote camera with cut edge guidance		✓	SERVICE AND MAINTENANCE		
CAT CONNECT TECHNOLOGY			Ports for Scheduled Oil Sampling (S·O·S SM)	✓	
Remote Troubleshoot capability	✓		Platform-level engine oil dipsticks	✓	
Cat Product Link	✓		1260 L (333 gal) onboard water tank	✓	
Cat GRADE	✓		Side water fill valve	✓	
Sonic sensor (averaging or string line)		✓	Water spray system	✓	
Ground level grade controls		✓	Air compressor		✓
CONVEYOR			Accessory drive system		✓
Material removal boost feature	✓		High pressure washdown		✓
Dust abatement system		✓	Low pressure washdown		✓
Hydraulic folding conveyor		✓	Additional water spray system		✓
Remote camera (loading conveyor)		✓	Remote Flash		✓
ROTOR SYSTEM			SAFETY AND SECURITY		
Automatic plunge-cut	✓		Platform handrails	✓	
Automatic transition feature	✓		Signaling/warning horn	✓	
Obstacle jump	✓		Halogen work lighting	✓	
Three cutting speeds	✓		LED work lighting (fixed, pole mounted, magnetic)		✓
System K Rotor - Standard (15 mm)	✓		Warning beacon (fixed)		✓
System K Rotor - Course (18 mm)		✓	Roading lights		✓
System K Rotor - Fine (8 mm)		✓	Truck signal lights		✓
Diamond bits		✓	Remote cameras (rear, front, cutting edges)		✓
Pneumatic bit removal tool		✓			
Tool holder extractor		✓			
Rotor turning device		✓			
Ballast kit		✓			

Cat® PM310 Cold Planer

Technical Specifications

Engine			
Engine Model	Cat C9.3		
Gross Engine Power – SAE J1995 U.S. EPA Tier 4 Final, EU Stage V, Korea Tier 4 Final	251 kW	336.6 hp	
Gross Engine Power – SAE J1995 Brazil MAR-1, equivalent to U.S. EPA Tier 3 and EU Stage IIIA	246 kW	330 hp	
Operating Speed	33 m/min	108 ft/min	
Maximum Travel Speed - Track	5.5 km/h	3.4 mph	
Maximum Travel Speed - Wheel	7.5 km/h	4.7 mph	

Cutting System			
Milling Width	1000 mm	39.4 in	
Number of Bits (15 mm spacing)	91		
Maximum Cutting Depth	330 mm	13.0 in	
Rotor Speeds	97 / 109 / 121 rpm		
Minimum Left Cutting Radius – Track	4.14 m	13.58 ft	
Minimum Left Cutting Radius – Wheel	4.23 m	13.88 ft	
Minimum Right Cutting Radius – Track	1.92 m	6.30 ft	
Minimum Right Cutting Radius – Wheel	2.00 m	6.56 ft	

Machine Weight			
Operating Weight – Track	21 780 kg	48,016 lbs	
Operating Weight – Wheel	21 080 kg	46,473 lbs	
Transport Weight – Track	20 168 kg	44,463 lbs	
Transport Weight – Wheel	19 468 kg	42,920 lbs	

Weights shown are approximate and include:

- Operating weights include coolants, lubricants, full fuel tank, full water tank and 75 kg (165 lb) operator.
- Transport weights include coolants, lubricants, 50% full fuel tank and empty water tank.

Service Refill Capacities			
Fuel Tank	600 L	158.5 gal	
Diesel Exhaust Fluid (DEF) Tank	22 L	5.8 gal	
Cooling System	62 L	16.4 gal	
Engine Oil	30 L	7.9 gal	
Hydraulic Oil	59 L	15.6 gal	
Water Tank	1260 L	332.9 gal	

Operating Dimensions			
A Overall Length (conveyor raised)	11.11 m	36.45 ft	
B Machine Width (leg in)	2.18 m	7.15 ft	
B' Machine Width (leg out)	2.54 m	8.33 ft	
C Maximum Height (conveyor raised)	5.15 m	16.90 ft	
D Height to Optional Canopy	3.75 m	12.30 ft	
E Maximum Truck Clearance	4.70 m	15.42 ft	
F Conveyor Length	7.08 m	23.23 ft	
G Conveyor Swing	±60° from center		

Shipping Dimensions			
H Transport Length	9.32 m	30.58 ft	
B' Transport Width (leg out)	2.54 m	8.33 ft	
D' Transport Height (canopy lowered)	3.00 m	9.84 ft	
I Length (track to track)	4.26 m	13.98 ft	
J Length of Machine (rear to front track)	5.04 m	16.54 ft	
K Length of Base Machine	5.90 m	19.36 ft	

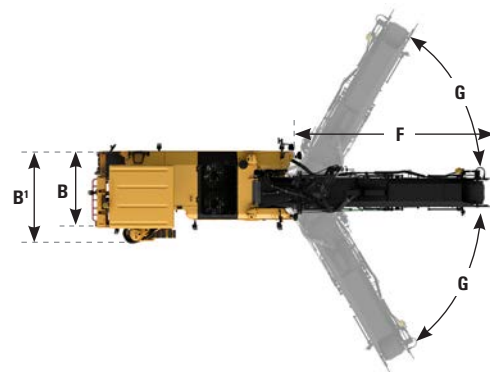
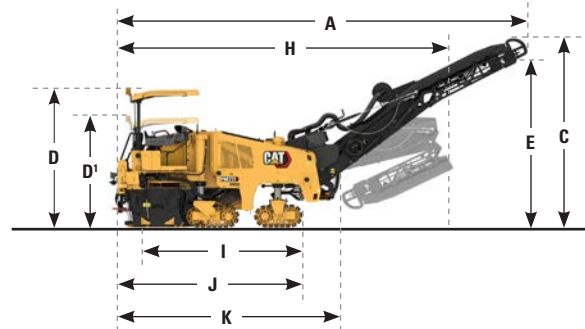

For more complete information on Cat products, dealer services, and industry solutions, visit us on the web at www.cat.com

© 2020 Caterpillar
All rights reserved

Materials and specifications are subject to change without notice. Featured machines in photos may include additional equipment. See your Cat dealer for available options.

CAT, CATERPILLAR, LET'S DO THE WORK, their respective logos, "Caterpillar Corporate Yellow," the "Power Edge" and Cat "Modern Hex" trade dress as well as corporate and product identity used herein, are trademarks of Caterpillar and may not be used without permission.

VisionLink is a trademark of Trimble Navigation Limited, registered in the United States and in other countries.

QEHQ2539-01 (06-2020)

Build Number: 02B
(Global)

