



M314

Wheeled Excavator

Technical Specifications

Configurations and features may vary by region. Please consult your Cat® dealer for availability in your area.

Table of Contents

Specifications	2
Engine	2
Transmission	2
Service Refill Capacities	2
Swing Mechanism	2
Undercarriage	2
Operating Weights	2
Major Component Weights	3
Hydraulic System	3
Dozer Blade	4
Emissions and Safety	4
Standards	4
Sound Performance	4
Air Conditioning System	4
Dimensions	5
Undercarriage Dimensions	7
Working Ranges	8
Bucket Specifications and Compatibility:	
North America	11
Europe	12
Australia and New Zealand	18
South Korea	20
Attachments Offering Guide:	
North America	22
Europe	26
Australia New Zealand	43
South Korea	46
Lift Capacities:	
Variable Adjustable Boom (5028 mm), 2200 mm Stick	47
Variable Adjustable Boom (5028 mm), 2500 mm Stick	49
Variable Adjustable Boom (5028 mm), 2900 mm Industrial Stick ..	51
One-Piece Boom (4650 mm), 2200 mm Stick	53
One-Piece Boom (4650 mm), 2500 mm Stick	55
One-Piece Boom (4650 mm), 2900 mm Industrial Stick	57
One-Piece Boom (4400 mm), 2200 mm Stick	59
One-Piece Boom (4400 mm), 2500 mm Stick	60
Standard and Optional Equipment	61
Dealer Installed Kits and Attachments	63
M314 Cab Options	64
M314 Environmental Declaration	65

M314 Wheeled Excavator Specifications

Engine

Engine Model	Cat® C3.6	
Engine Power		
ISO 14396:2002	100 kW	134 hp
ISO 14396:2002 (metric)	136 hp (PS)	
Net Power		
ISO 9249:2007	95 kW	127 hp
ISO 9249:2007 (metric)	129 hp (PS)	
Bore	98 mm	3.9 in
Stroke	120 mm	5 in
Displacement	3.6 L	221 in ³
Biodiesel Capability	Up to B20 ⁽¹⁾	
Number of Cylinders	4	

- Meets U.S. EPA Tier 4 Final, EU Stage V, and Korea Tier 5 emission standards.
- Net power advertised is the power available at the flywheel when engine is equipped with fan, air cleaner, CEM exhaust gas aftertreatment, alternator, and cooling fan running at intermediate speed.
- Rated speed 2,000 rpm.

⁽¹⁾Cat diesel engines are required to use ULSD (ultra-low sulfur diesel fuel with 15 ppm of sulfur or less) or ULSD blended with the following lower-carbon intensity fuels** up to:

- ✓ 20% biodiesel FAME (fatty acid methyl ester)*
- ✓ 100% renewable diesel, HVO (hydrotreated vegetable oil) and GTL (gas-to-liquid) fuels

Refer to guidelines for successful application. Please consult your Cat dealer or “Caterpillar Machine Fluids Recommendations” (SEBU6250) for details.

**Engines with no aftertreatment devices can use higher blends, up to 100% biodiesel (for use of blends higher than 20% biodiesel, consult your Cat dealer).*

***Tailpipe greenhouse gas emissions from lower-carbon intensity fuels are essentially the same as traditional fuels.*

Transmission

Forward/Reverse		
1st Gear	9 km/h	5.6 mph
2nd Gear	37 km/h	23 mph
Creeper Speed		
1st Gear	5 km/h	3.1 mph
2nd Gear	15 km/h	9.3 mph
Drawbar Pull	73 kN	16,411 lbf
Maximum Gradeability (15 000 kg/33,070 lb)	52.5%	

Service Refill Capacities

Fuel Tank (total capacity)	295 L	77.9 gal
Diesel Exhaust Fluid (DEF) Tank	20 L	5.3 gal
Cooling System	20 L	5.3 gal
Engine Oil	9 L	2.4 gal
Hydraulic Tank	90 L	23.8 gal
Hydraulic System (including tank)	220 L	58.1 gal
Rear Axle Housing (differential)	11.2 L	3 gal
Front Steering Axle (differential)	9 L	2.4 gal
Final Drive (each)	2.4 L	0.6 gal
Powershift Transmission	2.5 L	0.7 gal

Swing Mechanism

Maximum Swing Speed	9.1 rpm	
Maximum Swing Torque	41.3 kN·m	30,461 lbf-ft

Undercarriage

Ground Clearance	335 mm	1'1"
Maximum Steering Angle	35°	
Oscillation Axle Angle	8.5 ±°	
Minimum Turning Radius		
Outside of Tire	6250 mm	20'6"
Outside of Tire (plastic fender)	7450 mm	24'5"
End of VA Boom	7000 mm	23'0"
End of One-Piece Boom 4650 mm (15'3")	8000 mm	26'3"
End of One-Piece Boom 4400 mm (14'5")	6700 mm	22'0"

Operating Weights*

Minimum	14 600 kg	32,190 lb
Maximum	18 000 kg	39,680 lb
Typical Configurations		
Variable Adjustable Boom**		
Rear Blade Only	15 250 kg	33,620 lb
Rear Blade/Bucket Rest Front	15 550 kg	34,280 lb
Rear Outrigger/Front Blade	16 200 kg	35,710 lb
Front and Rear Outriggers	16 500 kg	36,380 lb
One-Piece Boom**		
Rear Blade Only	14 800 kg	32,630 lb
Rear Blade/Bucket Rest Front	15 100 kg	33,290 lb
Rear Outrigger/Front Blade	15 750 kg	34,720 lb
Front and Rear Outriggers	16 050 kg	35,380 lb

*Operating weight includes full fuel tank, operator, 500 kg (1,102 lb) bucket and dual pneumatic tires. Weight varies depending on configuration.

**Typical configurations include a 2200 mm (7'3") stick and a 210 kg (463 lb) quick coupler.

M314 Wheeled Excavator Specifications

Major Component Weights

Booms (including VA and stick cylinder, pins and standard hydraulic lines)		
Variable Adjustable Boom 5028 mm (16'6")	1860 kg	4,100 lb
One-Piece Boom 4650 mm (15'3")	1410 kg	3,110 lb
One-Piece Boom 4400 mm (14'5") ¹	1400 kg	3,090 lb
Sticks (including cylinder, bucket linkage, pins and standard hydraulic lines)		
Stick 2200 mm (7'3")	630 kg	1,390 lb
Stick 2500 mm (8'2")	620 kg	1,370 lb
Drop Nose Stick (no bucket linkage) 2900 mm (9'6")	380 kg	840 lb
Counterweight	3300 kg	7,280 lb
Undercarriage (including axles, standard tires and steps)		
Rear Blade	4100 kg	9,040 lb
Rear Blade/Bucket Rest Front	4400 kg	9,700 lb
Rear Blade/Front Outrigger	5050 kg	11,130 lb
Rear Blade Parallel	4500 kg	9,921 lb
Rear Blade Parallel with trailer	4565 kg	10,064 lb
Rear Outrigger/Front Blade	5050 kg	11,130 lb
Rear Outrigger/Front Outrigger	5350 kg	11,790 lb
Buckets (without linkage)		
CW Bucket GD 1200 mm (47"), 0.76 m ³ (0.99 yd ³), Advansys™	510 kg	1,120 lb
Pin-On Bucket GD 1200 mm (47"), 0.76 m ³ (0.99 yd ³), Advansys	500 kg	1,100 lb
Quick Couplers		
CW20	210 kg	460 lb
Pin Grabber	190 kg	420 lb

¹South Korea Only

Hydraulic System

Maximum Pressure – Implement Circuit		
Normal	35 000 kPa	5,076 psi
Heavy Lift	37 000 kPa	5,366 psi
Travel Circuit	35 000 kPa	5,076 psi
Maximum Pressure – Auxiliary Circuit		
High Pressure	35 000 kPa	5,076 psi
Medium Pressure	17 000 kPa	2,466 psi
Swing Mechanism	35 500 kPa	5,149 psi
Maximum Flow		
Implements	270 L/min	71.3 gal/min
Travel Circuit	200 L/min	52.8 gal/min
Auxiliary Circuit		
High Pressure	250 L/min	66.0 gal/min
Medium Pressure	62 L/min	16.4 gal/min
Swing Mechanism	83 L/min	21.9 gal/min
Cylinders		
Boom Cylinder (VA) – Bore	105 mm	4"
Boom Cylinder (VA) – Stroke	906 mm	3'0"
VAB Cylinder – Bore	130 mm	5"
VAB Cylinder – Stroke	753 mm	2'6"
Boom Cylinder (one-piece) – Bore	105 mm	4"
Boom Cylinder (one-piece) – Stroke	932 mm	3'1"
Stick Cylinder – Bore	110 mm	4"
Stick Cylinder – Stroke	1147 mm	3'9"
Bucket Cylinder – Bore	95 mm	4"
Bucket Cylinder – Stroke	939 mm	3'1"

M314 Wheeled Excavator Specifications

Dozer Blade

Blade Type	Radial	
Width	2540 mm	8'4"
Blade Roll-Over Height	540 mm	1'9"
Blade Total Height	580 mm	1'11"
Maximum Lowering Depth from Ground	120 mm	5"
Maximum Raising Height above Ground	475 mm	1'7"

Emissions and Safety

Engine Emissions	Tier 4 Final and Stage V	
Vibration Levels		
Maximum Hand/Arm (ISO 5349-2001)	<2.5 m/s ²	<8.2
Maximum Whole Body (ISO/TR 25398:2006)	<0.5 m/s ²	<1.6
Seat Transmissibility Factor (ISO 7096:2020-spectral class EM6)	<0.7	

Standards

Brakes	ISO 3450:2011
Cab Rollover Protective Structure (ROPS)	ISO 12117-2:2008
Operator Protective Guard (OPG) (optional top/front guards)	ISO 10262:1998 Level II
Cab/Sound Levels	Meets appropriate standards as listed below

Sound Performance

ISO 6396:2008 internal – 70 dB(A)
ISO 6395:2008 external – 100 dB(A)

- External Sound – The labelled spectator sound power level represents the Guaranteed Value per 2000/14/EC amended by 2005/88/EC, when properly equipped, and is measured according to the test procedures and conditions specified in ISO 6395:2008. The measurements were conducted at 70% of the maximum engine cooling fan speed.
- Internal Sound – The operator sound pressure level is measured according to the test procedures and conditions specified in ISO 6396:2008 for a cab offered by Caterpillar, when properly installed and maintained and tested with the door and windows closed. The measurements were conducted at 70% of the maximum engine cooling fan speed.
- Blue Angel Certified

Air Conditioning System

The air conditioning system on this machine contains the fluorinated greenhouse gas refrigerant R134a (Global Warming Potential = 1430). The system contains 0.8 kg of refrigerant, which has a CO₂ equivalent of 1.144 metric tonnes.

M314 Wheeled Excavator Specifications

Dimensions

All dimensions are approximate. Values are with 10.00-20 dual pneumatic tires.

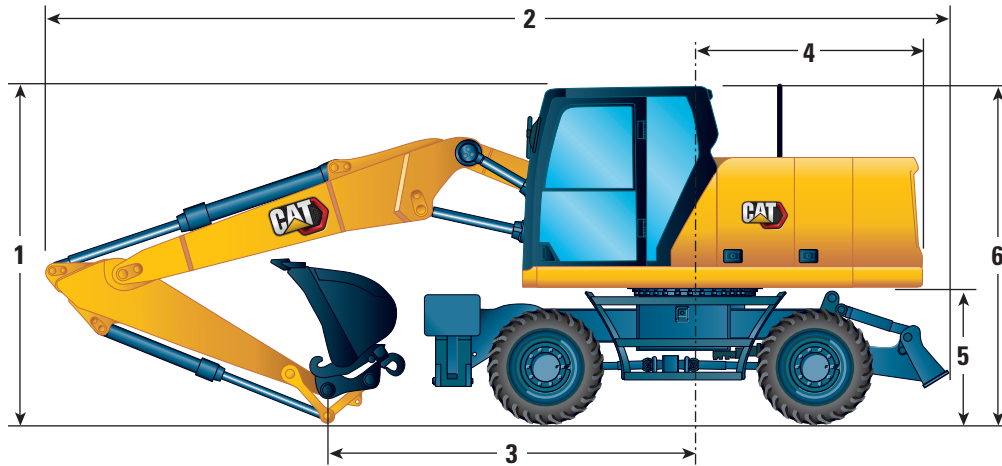

Boom Options	Variable Adjustable Boom 5028 mm (16'6")		
	Bucket Linkage 2200 mm (7'3")	Bucket Linkage 2500 mm (8'2")	Drop Nose* 2900 mm (9'6")
Stick Options			
1 Shipping Height with Operator Protective Guard (OPG) and Handrails Lowered (highest point between Boom and Cab)	3315 mm (10'11")	3315 mm (10'11")	3315 mm (10'11")
Shipping Height without OPG	2990 mm (9'10")	3080 mm (10'1")	3280 mm (10'9")
2 Shipping Length	8210 mm (26'11")	8210 mm (26'11")	8190 mm (26'10")
3 Support Point	3450 mm (11'4")	3280 mm (10'9")	3545 mm (11'8")
4 Tail Swing Radius	2150 mm (7'1")	2150 mm (7'1")	2150 mm (7'1")
5 Counterweight Clearance	1260 mm (4'2")	1260 mm (4'2")	1260 mm (4'2")
6 Cab Height			
No OPG, Handrails Lowered	3153 mm (10'4")	3153 mm (10'4")	3153 mm (10'4")
With OPG	3315 mm (10'11")	3315 mm (10'11")	3315 mm (10'11")
Overall Machine Width			
Width with Outriggers on Ground	3680 mm (12'1")	3680 mm (12'1")	3680 mm (12'1")
Width with Outriggers Up	2540 mm (8'4")	2540 mm (8'4")	2540 mm (8'4")
Width with Blade	2540 mm (8'4")	2540 mm (8'4")	2540 mm (8'4")
7 Width with Outriggers Fully Down	3645 mm (12'0")	3645 mm (12'0")	3645 mm (12'0")
8 Upperframe Width	2480 mm (8'2")	2480 mm (8'2")	2480 mm (8'2")
Roading Position			
9 Steering Wheel to Linkage in Roading Position	2630 mm (8'8")	2600 mm (8'6")	—
10 Height in Roading Position	3980 mm (13'1")	3980 mm (13'1")	—

*Without bucket linkage.

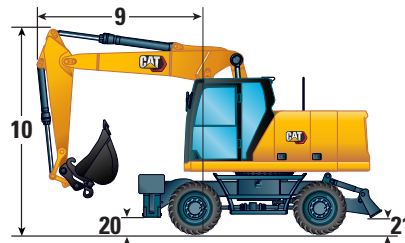
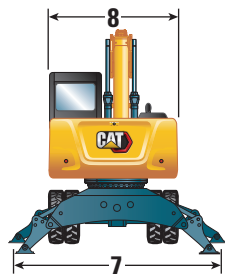

M314 Wheeled Excavator Specifications

Dimensions

All dimensions are approximate. Values are with 10.00-20 dual pneumatic tires.

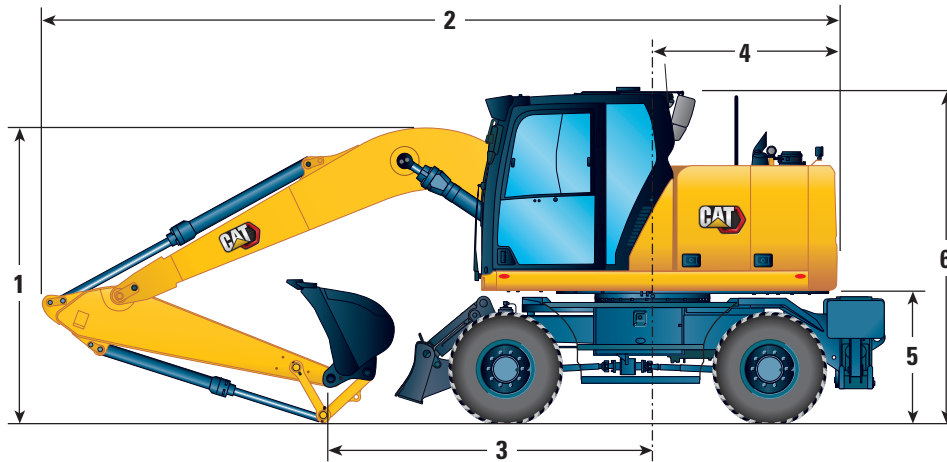

Boom Options	One-Piece Boom 4650 mm (15'3")			One-Piece Boom 4400 (14'5")		
	Stick Options	Bucket Linkage 2200 mm (7'3")	Bucket Linkage 2500 mm (8'2")	Drop Nose* 2900 mm (9'6")	Bucket Linkage 2200 mm (7'3")	2500 mm (8'2")
1 Shipping Height with Operator Protective Guard (OPG) and Handrails Lowered (highest point between Boom and Cab)		3315 mm (10'11")	3315 mm (10'11")	3315 mm (10'11")	3315 mm (10'11")	3315 mm (10'11")
Shipping Height without OPG		2850 mm (9'4")	2930 mm (9'7")	3060 mm (10'0")	2730 mm (8'11")	2800 mm (9'2")
2 Shipping Length		7770 mm (25'6")	7800 mm (25'7")	7890 mm (25'11")	7470 mm (24'6")	7500 mm (24'7")
3 Support Point		2800 mm (9'2")	2590 mm (8'6")	2870 mm (9'5")	2420 mm (7'11")	2180 mm (7'2")
4 Tail Swing Radius		2150 mm (7'1")	2150 mm (7'1")	2150 mm (7'1")	2150 mm (7'1")	2150 mm (7'1")
5 Counterweight Clearance		1260 mm (4'2")	1260 mm (4'2")	1260 mm (4'2")	1260 mm (4'2")	1260 mm (4'2")
6 Cab Height						
No OPG, Handrails Lowered		3153 mm (10'4")	3153 mm (10'4")	3153 mm (10'4")	3153 mm (10'4")	3153 mm (10'4")
With OPG		3315 mm (10'11")	3315 mm (10'11")	3315 mm (10'11")	3315 mm (10'11")	3315 mm (10'11")
Overall Machine Width						
Width with Outriggers on Ground		3680 mm (12'1")	3680 mm (12'1")	3680 mm (12'1")	3680 mm (12'1")	3680 mm (12'1")
Width with Outriggers Up		2540 mm (8'4")	2540 mm (8'4")	2540 mm (8'4")	2540 mm (8'4")	2540 mm (8'4")
Width with Blade		2540 mm (8'4")	2540 mm (8'4")	2540 mm (8'4")	2540 mm (8'4")	2540 mm (8'4")
7 Width with Outriggers Fully Down		3645 mm (12'0")	3645 mm (12'0")	3645 mm (12'0")	3645 mm (12'0")	3645 mm (12'0")
8 Upperframe Width		2480 mm (8'2")	2480 mm (8'2")	2480 mm (8'2")	2480 mm (8'2")	2480 mm (8'2")

*Without bucket linkage.

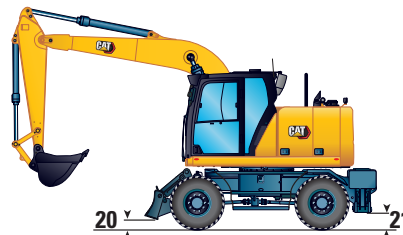

M314 Wheeled Excavator Specifications

Undercarriage Dimensions

All dimensions are approximate. Values are with 10.00-20 dual pneumatic tires.

Undercarriage	Rear Blade	Rear Blade/ Front Outrigger	Rear Outrigger/ Front Blade	Rear Outrigger/ Front Outrigger	Rear Blade/ Front Bucket Rest ¹
11 Overall Undercarriage Length	4310 mm (14'2")	4920 mm (16'2")	4920 mm (16'2")	4755 mm (15'7")	4545 mm (14'11")
12 Wheel Base	2500 mm (8'2")	2500 mm (8'2")	2500 mm (8'2")	2500 mm (8'2")	2800 mm (9'2")
13 Swing to Rear Axle	1100 mm (3'7")	1100 mm (3'7")	1100 mm (3'7")	1100 mm (3'7")	1100 mm (3'7")
14 Swing to Front Axle	1400 mm (4'7")	1400 mm (4'7")	1400 mm (4'7")	1400 mm (4'7")	1700 mm (5'7")
15 Rear Axle to Rear Outrigger (mid)	—	—	830 mm (2'9")	830 mm (2'9")	—
16 Front Axle to Front Outrigger (mid)	—	875 mm (2'10")	—	875 mm (2'10")	—
17 Rear Axle to Blade (end)	1270 mm (4'2")	1270 mm (4'2")	—	—	1270 mm (4'2")
Front Axle to Blade (end)	—	—	1270 mm (4'2")	—	—
18 Maximum Outrigger Depth	—	110 mm (4")	110 mm (4")	110 mm (4")	—
19 Blade Width	2540 mm (8'4")	2540 mm (8'4")	2540 mm (8'4")	—	2540 mm (8'4")
Maximum Blade Depth	120 mm (5")	120 mm (5")	120 mm (5")	—	120 mm (5")
Ground Clearance					
20 Outrigger Clearance	—	335 mm (1'1")	335 mm (1'1")	335 mm (1'1")	335 mm (1'1")
21 Blade Clearance	475 mm (1'7")	475 mm (1'7")	475 mm (1'7")	475 mm (1'7")	475 mm (1'7")
22 Axle Clearance	360 mm (1'2")	360 mm (1'2")	360 mm (1'2")	360 mm (1'2")	360 mm (1'2")

¹South Korea Only

*Maximum tire clearance
with outrigger fully down

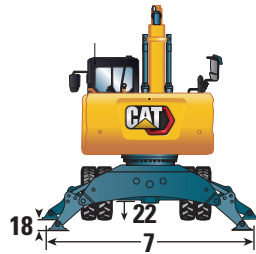

Undercarriage with dozer only

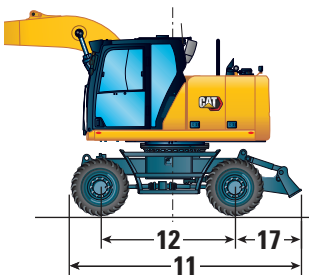

Undercarriage with 2 sets of outriggers

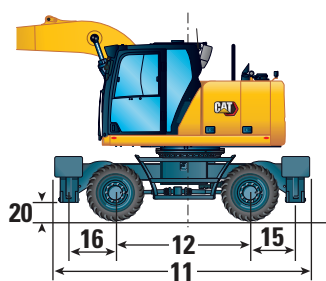

Undercarriage with 1 set of outriggers and dozer

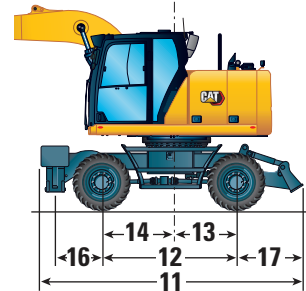

M314 Wheeled Excavator Specifications

Working Ranges

All dimensions are approximate. Values are with 10.00-20 dual pneumatic tires.

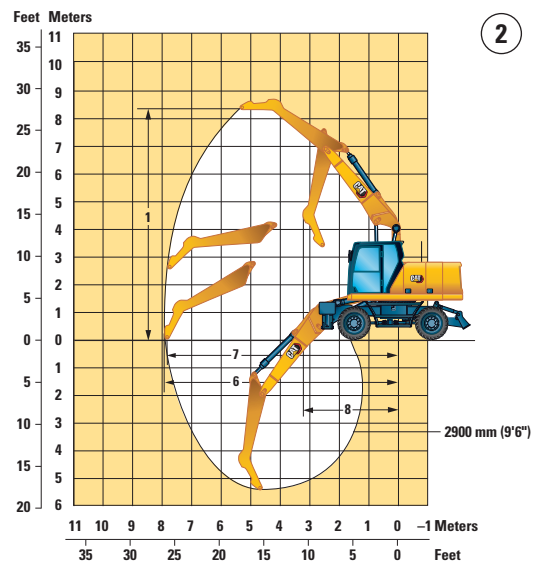
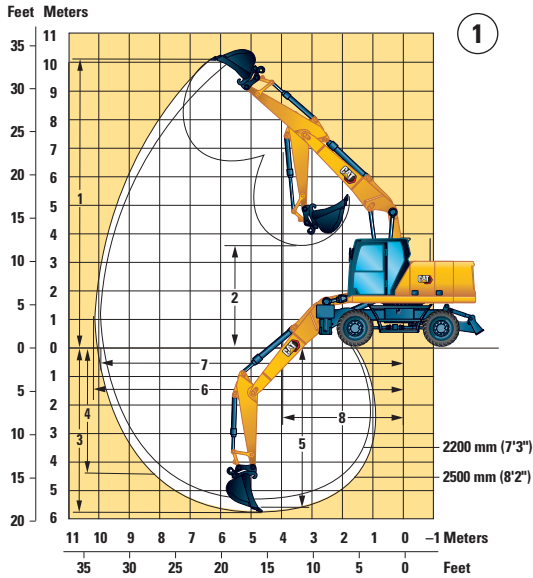

Boom Option

Variable Adjustable Boom 5028 mm (16'6")

Stick Options	Variable Adjustable Boom 5028 mm (16'6")		
	① Bucket Linkage 2200 mm (7'3")	② Bucket Linkage 2500 mm (8'2")	③ Drop Nose 2900 mm (9'6")
1 Digging Height	9780 mm (32'1")	10 020 mm (32'10")	8530 mm (28'0")
2 Dump Height	7010 mm (23'0")	7240 mm (23'9")	—
3 Digging Depth	5290 mm (17'4")	5580 mm (18'4")	4510 mm (14'9")
4 Vertical Wall Digging Depth	4250 mm (13'11")	4580 mm (15'0")	—
5 Depth 2.5 m (8'2") in Straight Clean-Up	5170 mm (17'0")	5480 mm (18'0")	—
6 Reach	8830 mm (29'0")	9120 mm (29'11")	7920 mm (26'0")
7 Reach at Ground Level	8650 mm (28'5")	8940 mm (29'4")	7720 mm (25'4")
8 Minimum Front Linkage Radius	2600 mm (8'6")	2700 mm (8'10")	3450 mm (11'4")
Bucket Forces (ISO)	105 kN (23,605 lbf)	105 kN (23,605 lbf)	—
Stick Forces (ISO)	71 kN (15,961 lbf)	65 kN (14,613 lbf)	—
Bucket Type	GD	GD	—
Bucket Capacity	0.76 m ³ (0.99 yd ³)	0.76 m ³ (0.99 yd ³)	—
Bucket Tip Radius (Pin-On)	1224 mm (4'0")	1224 mm (4'0")	—
Bucket Tip Radius (QC)	1387 mm (4'7")	1387 mm (4'7")	—

Range values are with dual pneumatic tires (10.00-20).

A drop nose stick has no bucket linkage and working range dimensions refer to the stick nose pin.

Range values are calculated with a GD bucket (CW-S) and CW-20S-D.4.N quick coupler with a tip radius of 1387 mm (4'7").

Force values are calculated with heavy lift on, a GD bucket (pin-on) and a tip radius of 1224 mm (4'0").

M314 Wheeled Excavator Specifications

Working Ranges

All dimensions are approximate. Values are with 10.00-20 dual pneumatic tires.

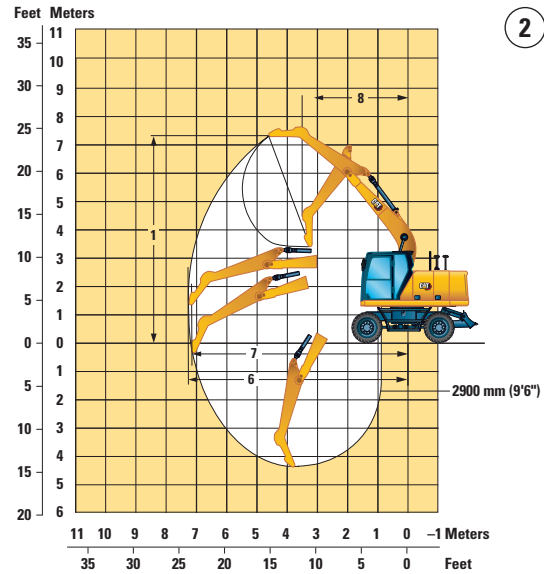
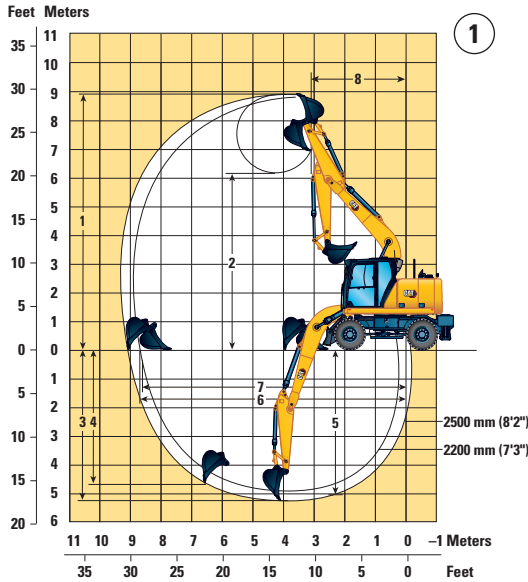

Boom Option

One-Piece Boom 4650 mm (14'5")

Stick Options	①		②
	Bucket Linkage 2200 mm (7'3")	Bucket Linkage 2500 mm (8'2")	Drop Nose 2900 mm (9'6")
1 Digging Height	8760 mm (28'9")	8940 mm (29'4")	7320 mm (24'0")
2 Dump Height	6030 mm (19'9")	6210 mm (20'4")	—
3 Digging Depth	4950 mm (16'3")	5250 mm (17'3")	—
4 Vertical Wall Digging Depth	4290 mm (14'1")	4650 mm (15'3")	—
5 Depth 2.5 m (8'2") in Straight Clean-Up	4730 mm (15'6")	5050 mm (16'7")	—
6 Reach	8380 mm (27'6")	8660 mm (28'5")	7410 mm (24'4")
7 Reach at Ground Level	8190 mm (26'10")	8470 mm (27'9")	7200 mm (23'7")
8 Minimum Front Linkage Radius	2710 mm (8'11")	2670 mm (8'9")	3560 mm (11'8")
Bucket Forces (ISO)	105 kN (23,605 lbf)	105 kN (23,605 lbf)	—
Stick Forces (ISO)	71 kN (15,961 lbf)	65 kN (14,613 lbf)	—
Bucket Type	GD	GD	—
Bucket Capacity	0.76 m ³ (0.99 yd ³)	0.76 m ³ (0.99 yd ³)	—
Bucket Tip Radius (Pin-On)	1224 mm (4'0")	1224 mm (4'0")	—
Bucket Tip Radius (QC)	1387 mm (4'7")	1387 mm (4'7")	—

Range values are with dual pneumatic tires (10.00-20).

A drop nose stick has no bucket linkage and working range dimensions refer to the stick nose pin.

Range values are calculated with a GD bucket (CW-S) and CW-20S-D.4.N quick coupler with a tip radius of 1387 mm (4'7").

Force values are calculated with heavy lift on, a GD bucket (pin-on) and a tip radius of 1224 mm (4'0").

M314 Wheeled Excavator Specifications

Working Ranges

All dimensions are approximate. Values are with 10.00-20 dual pneumatic tires.

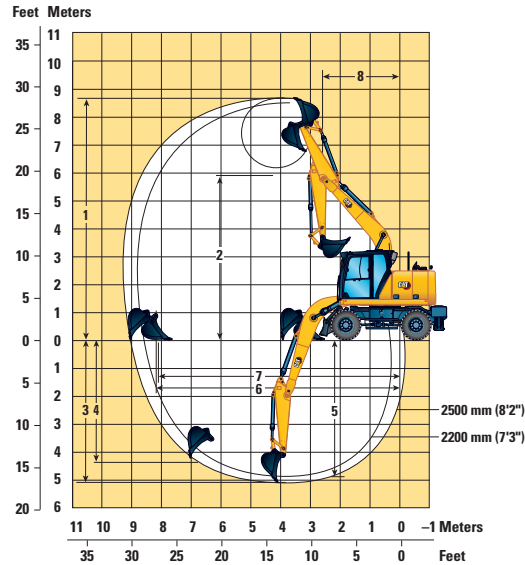

Boom Option

One-Piece Boom
4400 mm (14'5")¹

Stick Options

Bucket Linkage 2200 mm (7'3")

Bucket Linkage 2500 mm (8'2")

1 Digging Height	8430 mm (27'8")	8610 mm (28'3")
2 Dump Height	5720 mm (18'9")	5900 mm (19'4")
3 Digging Depth	4780 mm (15'8")	5090 mm (16'8")
4 Vertical Wall Digging Depth	3980 mm (13'1")	4340 mm (14'3")
5 Depth 2.5 m (8'2") in Straight Clean-Up	4560 mm (15'0")	4880 mm (16'0")
6 Reach	8100 mm (26'7")	8380 mm (27'6")
7 Reach at Ground Level	7900 mm (25'11")	8190 mm (26'10")
8 Minimum Front Linkage Radius	2610 mm (8'7")	2570 mm (8'5")
Bucket Forces (ISO)	105 kN (23,605 lbf)	105 mm (23,605 lbf)
Stick Forces (ISO)	71 kN (15,961 lbf)	65 kN (14,613 lbf)
Bucket Type	GD	GD
Bucket Capacity	0.76 m ³ (0.99 yd ³)	0.76 m ³ (0.99 yd ³)
Bucket Tip Radius (Pin-On)	1224 mm (4'0")	1224 mm (4'0")
Bucket Tip Radius (QC)	1387 mm (4'7")	1387 mm (4'7")

¹South Korea Only

Range values are with dual pneumatic tires (10.00-20).

A drop nose stick has no bucket linkage and working range dimensions refer to the stick nose pin.

Range values are calculated with a GD bucket (CW-S) and CW-20S-D.4.N quick coupler with a tip radius of 1387 mm (4'7").

Force values are calculated with heavy lift on, a GD bucket (pin-on) and a tip radius of 1224 mm (4'0").

M314 Wheeled Excavator Specifications

Bucket Specifications and Compatibility – North America

Contact your Cat dealer for special bucket requirements.

Linkage	Width		Capacity		Weight		Fill	3300 kg (7,280 lb) Counterweight										
								Variable Adjustable Boom										
								2200 mm (7'3") Stick				2500 mm (8'2") Stick						
								Free on wheels	Rear dozer blade lowered	Front dozer and rear stabilizer lowered	Four stabilizers lowered	Free on wheels	Rear dozer blade lowered	Front dozer and rear stabilizer lowered	Four stabilizers lowered			
Pin-On (No Quick Coupler)																		
General Duty (GD)	312	450	18	0.20	0.27	278	614	100	●	●	●	●	●	●	●	●	●	
	312	600	24	0.31	0.40	320	706	100	●	●	●	●	●	●	●	●	●	
	312	750	30	0.41	0.54	369	815	100	●	●	●	●	●	●	●	●	●	
	312	900	36	0.53	0.69	425	936	100	⊙	●	●	●	⊙	●	●	●	●	
	312	1050	42	0.65	0.84	468	1,031	100	⊖	⊙	●	●	⊖	⊙	●	●	●	
General Duty (GD) – Wide Tip	312	1200	48	0.76	1.00	508	1,119	100	○	⊖	●	●	○	⊖	●	●	●	
	312	450	18	0.27	0.36	317	700	100	●	●	●	●	●	●	●	●	●	
	312	600	24	0.41	0.53	372	821	100	●	●	●	●	●	●	●	●	●	
	312	900	36	0.71	0.92	478	1,053	100	○	⊙	●	●	○	⊖	●	●	●	
Severe Duty (SD)	312	1050	42	0.86	1.13	530	1,168	100	◇	○	●	●	◇	○	●	●	●	
	312	600	24	0.31	0.40	374	825	90	●	●	●	●	●	●	●	●	●	
	312	750	30	0.41	0.54	434	957	90	●	●	●	●	●	●	●	●	●	
	312	900	36	0.53	0.69	495	1,091	90	●	●	●	●	⊙	●	●	●	●	
Ditch Cleaning (DC)	312	1050	42	0.65	0.84	541	1,192	90	⊖	⊙	●	●	⊖	⊙	●	●	●	
	312	1200	48	0.74	0.74	388	855	100	⊙	●	●	●	⊙	●	●	●	●	
	312	1500	60	0.74	0.97	455	1,003	100	○	⊖	●	●	○	⊖	●	●	●	
Ditch Cleaning Tilt (DCT)	312	1200	48	0.48	0.63	563	1,240	100	⊙	●	●	●	⊙	●	●	●	●	
	312	1500	60	0.57	0.75	646	1,424	100	⊖	⊙	●	●	○	⊖	●	●	●	
Maximum load with pin-on (payload + bucket)								kg	1468	1696	2826	3465	1396	1612	2679	3280		
								lb	3,237	3,740	6,230	7,638	3,077	3,554	5,906	7,230		
With Cat Pin Grabber Coupler																		
General Duty (GD)	312	450	18	0.20	0.27	278	614	100	●	●	●	●	●	●	●	●	●	
	312	600	24	0.31	0.40	320	706	100	●	●	●	●	●	●	●	●	●	
	312	750	30	0.41	0.54	369	815	100	●	●	●	●	●	●	●	●	●	
	312	900	36	0.53	0.69	425	936	100	⊙	●	●	●	⊙	●	●	●	●	
	312	1050	42	0.65	0.84	468	1,031	100	⊖	⊙	●	●	⊖	⊙	●	●	●	
General Duty (GD) – Wide Tip	312	1200	48	0.76	1.00	508	1,119	100	○	⊖	●	●	○	⊖	●	●	●	
	312	450	18	0.27	0.36	317	700	100	●	●	●	●	●	●	●	●	●	
	312	600	24	0.41	0.53	372	821	100	●	●	●	●	●	●	●	●	●	
	312	750	30	0.55	0.72	425	936	100	⊙	●	●	●	⊙	●	●	●	●	
Severe Duty (SD)	312	900	36	0.71	0.92	478	1,053	100	○	⊙	●	●	○	⊖	●	●	●	
	312	1050	42	0.86	1.13	530	1,168	100	◇	○	●	●	◇	○	●	●	●	
	312	600	24	0.31	0.40	374	825	90	●	●	●	●	●	●	●	●	●	
	312	750	30	0.41	0.54	434	957	90	●	●	●	●	●	●	●	●	●	
Ditch Cleaning (DC)	312	900	36	0.53	0.69	495	1,091	90	●	●	●	●	⊙	●	●	●	●	
	312	1050	42	0.65	0.84	541	1,192	90	⊖	⊙	●	●	⊖	⊙	●	●	●	
	312	1200	48	0.57	0.74	388	855	100	⊙	●	●	●	⊙	●	●	●	●	
Ditch Cleaning Tilt (DCT)	312	1500	60	0.74	0.97	455	1,003	100	○	⊖	●	●	○	⊖	●	●	●	
	312	1200	48	0.48	0.63	563	1,240	100	⊙	●	●	●	⊙	●	●	●	●	
Ditch Cleaning Tilt (DCT)	312	1500	60	0.57	0.75	646	1,424	100	⊖	⊙	●	●	○	⊖	●	●	●	
	Maximum load with coupler (payload + bucket)								kg	1268	1497	2626	3265	1196	1412	2479	3080	
								lb	2,796	3,299	5,790	7,198	2,637	3,113	5,466	6,790		

Maximum Material Density:

- 2100 kg/m³ (3,500 lb/yd³)
- ⊙ 1800 kg/m³ (3,000 lb/yd³)
- ⊖ 1500 kg/m³ (2,500 lb/yd³)
- 1200 kg/m³ (2,000 lb/yd³)
- ◇ 900 kg/m³ (1,500 lb/yd³)
- X Not Recommended

The above loads are in compliance with hydraulic excavator standard EN474-5:2006+A3:2013, they do not exceed 87% of hydraulic lifting capacity or 75% of tipping capacity with front linkage fully extended at ground line with bucket curled. Capacity based on ISO 7451:2007.

Caterpillar recommends using appropriate work tools to maximize the value customers receive from our products. Use of work tools, including buckets, which are outside of Caterpillar's recommendations or specifications for weight, dimensions, flows, pressures, etc. may result in less-than-optimal performance, including but not limited to reductions in production, stability, reliability, and component durability. Improper use of a work tool resulting in sweeping, prying, twisting and/or catching of heavy loads will reduce the life of the boom and stick.

M314 Wheeled Excavator Specifications

Bucket Specifications and Compatibility – Europe

Contact your Cat dealer for special bucket requirements.

Linkage	Width		Capacity		Weight		Fill	3300 kg (7,280 lb) Counterweight										
								Variable Adjustable Boom										
								2200 mm (7'3") Stick				2500 mm (8'2") Stick						
								Free on wheels	Rear dozer blade lowered	Front dozer and rear stabilizer lowered	Four stabilizers lowered	Free on wheels	Rear dozer blade lowered	Front dozer and rear stabilizer lowered	Four stabilizers lowered			
Pin-On (No Quick Coupler)																		
Utility Duty (UD)	312	600	24	0.31	0.40	327	722	100	●	●	●	●	●	●	●	●	●	
	312	1200	48	0.76	1.00	515	1,134	100	○	⊖	●	●	○	⊖	●	●		
General Duty (GD)	312	600	24	0.31	0.40	317	699	100	●	●	●	●	●	●	●	●		
	312	1000	39	0.60	0.78	439	969	100	⊙	●	●	●	⊖	⊙	●	●		
General Duty (GD) (No Adjuster)	312	1100	43	0.68	0.89	474	1,046	100	⊖	⊙	●	●	○	⊖	●	●		
	312	450	18	0.20	0.26	267	589	100	●	●	●	●	●	●	●	●		
	312	500	20	0.24	0.31	287	633	100	●	●	●	●	●	●	●	●		
	312	750	30	0.41	0.54	358	790	100	●	●	●	●	●	●	●	●		
	312	900	36	0.53	0.69	426	939	100	⊙	●	●	●	⊙	●	●	●		
	312	1050	42	0.65	0.84	479	1,055	100	⊖	⊙	●	●	○	⊙	●	●		
Heavy Duty (HD)	312	1200	48	0.76	1.00	519	1,143	100	○	⊖	●	●	○	⊖	●	●		
	312	450	18	0.20	0.27	289	637	100	●	●	●	●	●	●	●	●		
	312	1200	48	0.76	0.99	533	1,174	100	○	⊖	●	●	◇	○	●	●		
Severe Duty (SD)	312	900	36	0.53	0.69	475	1,047	90	●	●	●	●	⊙	●	●	●		
Ditch Cleaning (DC)	312	1800	72	0.68	0.89	540	1,191	100	○	⊖	●	●	○	⊖	●	●		
	312	1800	71	0.57	0.74	421	928	100	⊙	●	●	●	⊙	●	●	●		
Ditch Cleaning Tilt (DCT)	312	1800	72	0.60	0.78	724	1,597	100	○	⊖	●	●	◇	⊖	●	●		
Maximum load with pin-on (payload + bucket)								kg	1468	1696	2826	3465	1396	1612	2679	3280		
								lb	3,237	3,740	6,230	7,638	3,077	3,554	5,906	7,230		
With Cat Pin Grabber Coupler																		
Utility Duty (UD)	312	600	24	0.31	0.40	327	722	100	●	●	●	●	●	●	●	●		
	312	1200	48	0.76	1.00	515	1,134	100	○	⊖	●	●	○	⊖	●	●		
General Duty (GD)	312	600	24	0.31	0.40	317	699	100	●	●	●	●	●	●	●	●		
	312	1000	39	0.60	0.78	439	969	100	⊙	●	●	●	⊖	⊙	●	●		
General Duty (GD) (No Adjuster)	312	1100	43	0.68	0.89	474	1,046	100	⊖	⊙	●	●	○	⊖	●	●		
	312	450	18	0.20	0.26	267	589	100	●	●	●	●	●	●	●	●		
	312	500	20	0.24	0.31	287	633	100	●	●	●	●	●	●	●	●		
	312	750	30	0.41	0.54	358	790	100	●	●	●	●	●	●	●	●		
	312	900	36	0.53	0.69	426	939	100	⊙	●	●	●	⊙	●	●	●		
	312	1050	42	0.65	0.84	479	1,055	100	⊖	⊙	●	●	○	⊙	●	●		
Heavy Duty (HD)	312	1200	48	0.76	1.00	519	1,143	100	○	⊖	●	●	○	⊖	●	●		
	312	450	18	0.20	0.27	289	637	100	●	●	●	●	●	●	●	●		
312	1200	48	0.76	0.99	533	1,174	100	○	⊖	●	●	◇	○	●	●			
Severe Duty (SD)	312	900	36	0.53	0.69	475	1,047	90	●	●	●	●	⊙	●	●	●		
Ditch Cleaning (DC)	312	1800	72	0.68	0.89	540	1,191	100	○	⊖	●	●	○	⊖	●	●		
	312	1800	71	0.57	0.74	421	928	100	⊙	●	●	●	⊙	●	●	●		
Maximum load with coupler (payload + bucket)								kg	1268	1497	2626	3265	1196	1412	2479	3080		
								lb	2,796	3,299	5,790	7,198	2,637	3,113	5,466	6,790		

Maximum Material Density:

- 2100 kg/m³ (3,500 lb/yd³)
- ⊙ 1800 kg/m³ (3,000 lb/yd³)
- ⊖ 1500 kg/m³ (2,500 lb/yd³)
- 1200 kg/m³ (2,000 lb/yd³)
- ◇ 900 kg/m³ (1,500 lb/yd³)

The above loads are in compliance with hydraulic excavator standard EN474-5:2006+A3:2013, they do not exceed 87% of hydraulic lifting capacity or 75% of tipping capacity with front linkage fully extended at ground line with bucket curled. Capacity based on ISO 7451:2007.

Caterpillar recommends using appropriate work tools to maximize the value customers receive from our products. Use of work tools, including buckets, which are outside of Caterpillar's recommendations or specifications for weight, dimensions, flows, pressures, etc. may result in less-than-optimal performance, including but not limited to reductions in production, stability, reliability, and component durability. Improper use of a work tool resulting in sweeping, prying, twisting and/or catching of heavy loads will reduce the life of the boom and stick.

(continued on next page)

M314 Wheeled Excavator Specifications

Bucket Specifications and Compatibility – Europe (continued)

Contact your Cat dealer for special bucket requirements.

	Linkage	Width		Capacity		Weight		Fill	3300 kg (7,280 lb) Counterweight									
		Variable Adjustable Boom								2200 mm (7'3") Stick				2500 mm (8'2") Stick				
		mm	in	m ³	yd ³	kg	lb		%	Free on wheels	Rear dozer blade lowered	Front dozer and rear stabilizer lowered	Four stabilizers lowered	Free on wheels	Rear dozer blade lowered	Front dozer and rear stabilizer lowered	Four stabilizers lowered	
With CW20 Coupler																		
General Duty (GD)	CW20	600	24	0.31	0.40	344	758	100	●	●	●	●	●	●	●			
	CW20	900	36	0.53	0.69	426	940	100	⊖	●	●	●	⊖	⊙	●	●		
	CW20	1100	43	0.68	0.89	487	1,073	100	○	⊖	●	●	⊖	○	●	●		
Heavy Duty (HD)	CW20	1200	48	0.76	1.00	526	1,159	100	◇	○	●	●	◇	○	●	●		
General Duty (GD) Leveling Edge	CW20	690	27	0.40	0.52	410	904	100	●	●	●	●	⊙	●	●	●		
	CW20	790	31	0.47	0.61	452	997	100	⊙	●	●	●	⊖	●	●	●		
	CW20	996	39	0.63	0.83	515	1,135	100	○	⊖	●	●	○	○	●	●		
	CW20	1184	47	0.80	1.05	601	1,324	100	X	◇	●	●	X	◇	●	●		
Ditch Cleaning (DC)	CW20	1800	72	0.68	0.89	516	1,138	100	◇	⊖	●	●	◇	○	●	●		
	CW20	1800	72	0.90	1.18	554	1,221	100	X	◇	●	●	X	◇	●	●		
Maximum load with coupler (payload + bucket)								kg	1263	1491	2621	3260	1191	1407	2474	3075		
								lb	2,785	3,288	5,778	7,186	2,626	3,102	5,454	6,778		
With CW20S Coupler																		
General Duty (GD)	CW20S	450	18	0.20	0.26	302	666	100	●	●	●	●	●	●	●	●		
	CW20S	500	20	0.24	0.31	311	686	100	●	●	●	●	●	●	●	●		
	CW20S	600	24	0.31	0.40	330	728	100	●	●	●	●	●	●	●	●		
	CW20S	750	30	0.41	0.54	377	832	100	●	●	●	●	●	●	●	●		
	CW20S	900	36	0.53	0.69	426	940	100	⊖	●	●	●	⊖	⊙	●	●		
	CW20S	1000	39	0.60	0.78	451	995	100	○	⊙	●	●	○	⊖	●	●		
	CW20S	1100	43	0.68	0.89	487	1,073	100	○	⊖	●	●	◇	○	●	●		
Heavy Duty (HD)	CW20S	1200	48	0.76	1.00	516	1,137	100	◇	○	●	●	◇	○	●	●		
	CW20S	500	20	0.24	0.31	321	708	100	●	●	●	●	●	●	●	●		
Ditch Cleaning (DC)	CW20S	1200	48	0.76	1.00	526	1,160	100	◇	○	●	●	◇	○	●	●		
Ditch Cleaning (DCT)	CW20S	1800	72	0.68	0.89	457	1,008	100	○	⊖	●	●	◇	⊖	●	●		
Ditch Cleaning Tilt (DCT)	CW20S	1800	72	0.60	0.78	732	1,614	100	◇	○	●	●	X	○	●	●		
Maximum load with coupler (payload + bucket)								kg	1285	1513	2643	3282	1213	1429	2496	3097		
								lb	2,833	3,336	5,827	7,235	2,674	3,150	5,503	6,827		
Pin-On, TRS10 CW20																		
Grading – General Duty	312	1600	63	0.76	0.99	571	1,259	100	X	X	●	●	X	X	●	●		
Maximum load with pin-on (payload + bucket)								kg	923	1151	2281	2920	851	1067	2134	2735		
								lb	2,035	2,538	5,029	6,437	1,876	2,352	4,704	6,029		

Maximum Material Density:

- 2100 kg/m³ (3,500 lb/yd³)
- ⊙ 1800 kg/m³ (3,000 lb/yd³)
- ⊖ 1500 kg/m³ (2,500 lb/yd³)
- 1200 kg/m³ (2,000 lb/yd³)
- ◇ 900 kg/m³ (1,500 lb/yd³)
- X Not Recommended

The above loads are in compliance with hydraulic excavator standard EN474-5:2006+A3:2013, they do not exceed 87% of hydraulic lifting capacity or 75% of tipping capacity with front linkage fully extended at ground line with bucket curled. Capacity based on ISO 7451:2007.

Caterpillar recommends using appropriate work tools to maximize the value customers receive from our products. Use of work tools, including buckets, which are outside of Caterpillar's recommendations or specifications for weight, dimensions, flows, pressures, etc. may result in less-than-optimal performance, including but not limited to reductions in production, stability, reliability, and component durability. Improper use of a work tool resulting in sweeping, prying, twisting and/or catching of heavy loads will reduce the life of the boom and stick.

(continued on next page)

M314 Wheeled Excavator Specifications

Bucket Specifications and Compatibility – Europe (continued)

Contact your Cat dealer for special bucket requirements.

	Linkage	Width		Capacity		Weight		Fill	3300 kg (7,280 lb) Counterweight								
		Variable Adjustable Boom							2200 mm (7'3") Stick				2500 mm (8'2") Stick				
		mm	in	m ³	yd ³	kg	lb		%	Free on wheels	Rear dozer blade lowered	Front dozer and rear stabilizer lowered	Four stabilizers lowered	Free on wheels	Rear dozer blade lowered	Front dozer and rear stabilizer lowered	Four stabilizers lowered
Pin-On, TRS10 CW20S																	
Grading – General Duty	312	1500	59	0.65	0.85	528	1,164	100	X	◇	●	●	X	X	●	●	
Trenching – General Duty	312	540	21	0.37	0.48	336	740	100	⊖	●	●	●	○	⊙	●	●	
								kg	912	1140	2270	2909	840	1056	2123	2724	
								lb	2,011	2,514	5,004	6,413	1,852	2,328	4,680	6,004	
Pin-On, TRS10 S60																	
Grading – Heavy Duty	312	1500	59	0.52	0.68	511	1,127	100	◇	⊖	●	●	◇	○	●	●	
	312	1500	59	0.65	0.85	535	1,179	100	X	◇	●	●	X	◇	●	●	
	312	1600	63	0.75	0.98	576	1,270	100	X	◇	●	●	X	X	●	●	
Trenching – Heavy Duty	312	540	21	0.33	0.43	320	706	100	●	●	●	●	⊙	●	●	●	
								kg	1041	1269	2399	3038	969	1185	2252	2853	
								lb	2,295	2,798	5,289	6,697	2,136	2,612	4,965	6,289	
With CW20S, TRS10 CW20S																	
Grading – Heavy Duty	312	1500	59	0.65	0.85	528	1,164	100	X	X	●	●	X	X	●	●	
Trenching – Heavy Duty	312	540	21	0.37	0.48	336	740	100	◇	⊖	●	●	X	⊖	●	●	
								kg	719	947	2077	2716	647	863	1930	2531	
								lb	1,585	2,089	4,579	5,987	1,426	1,903	4,255	5,579	
With S60, TRS10 S60																	
Grading – Heavy Duty	312	1500	59	0.52	0.68	511	1,127	100	X	○	●	●	X	◇	●	●	
	312	1500	59	0.65	0.85	535	1,179	100	X	◇	●	●	X	X	●	●	
	312	1600	63	0.75	0.98	576	1,270	100	X	X	●	●	X	X	●	●	
Trenching – Heavy Duty	312	540	21	0.33	0.43	320	706	100	⊖	●	●	●	⊖	●	●	●	
								kg	881	1109	2239	2878	809	1025	2092	2693	
								lb	1,942	2,446	4,936	6,344	1,783	2,260	4,612	5,936	

Maximum Material Density:

- 2100 kg/m³ (3,500 lb/yd³)
- ⊙ 1800 kg/m³ (3,000 lb/yd³)
- ⊖ 1500 kg/m³ (2,500 lb/yd³)
- 1200 kg/m³ (2,000 lb/yd³)
- ◇ 900 kg/m³ (1,500 lb/yd³)
- X Not Recommended

The above loads are in compliance with hydraulic excavator standard EN474-5:2006+A3:2013, they do not exceed 87% of hydraulic lifting capacity or 75% of tipping capacity with front linkage fully extended at ground line with bucket curled.

Capacity based on ISO 7451:2007.

Caterpillar recommends using appropriate work tools to maximize the value customers receive from our products. Use of work tools, including buckets, which are outside of Caterpillar's recommendations or specifications for weight, dimensions, flows, pressures, etc. may result in less-than-optimal performance, including but not limited to reductions in production, stability, reliability, and component durability. Improper use of a work tool resulting in sweeping, prying, twisting and/or catching of heavy loads will reduce the life of the boom and stick.

(continued on next page)

M314 Wheeled Excavator Specifications

Bucket Specifications and Compatibility – Europe (continued)

Contact your Cat dealer for special bucket requirements.

	Linkage	Width		Capacity		Weight		Fill %	3300 kg (7,280 lb) Counterweight 4650 mm (15'3") One-Piece Boom											
		mm	in	m ³	yd ³	kg	lb		2200 mm (7'3") Stick				2500 mm (8'2") Stick							
									Free on wheels	Rear dozer blade lowered	Front dozer and rear stabilizer lowered	Four stabilizers lowered	Free on wheels	Rear dozer blade lowered	Front dozer and rear stabilizer lowered	Four stabilizers lowered				
											●	⊙	●	●	●	⊙	●	●	●	●
Pin-On (No Quick Coupler)																				
Utility Duty (UD)	312	600	24	0.31	0.40	327	722	100	●	●	●	●	●	●	●	●	●	●	●	
	312	1200	48	0.76	1.00	515	1,134	100	⊖	⊙	●	●	⊖	⊙	●	●	●	●	●	
General Duty (GD)	312	600	24	0.31	0.40	317	699	100	●	●	●	●	●	●	●	●	●	●	●	
	312	1000	39	0.60	0.78	439	969	100	●	●	●	●	●	●	●	●	●	●	●	
	312	1100	43	0.68	0.89	474	1,046	100	⊙	●	●	●	⊙	●	●	●	●	●	●	
	312	450	18	0.20	0.26	267	589	100	●	●	●	●	●	●	●	●	●	●	●	
	312	500	20	0.24	0.31	287	633	100	●	●	●	●	●	●	●	●	●	●	●	
	312	750	30	0.41	0.54	358	790	100	●	●	●	●	●	●	●	●	●	●	●	●
	312	900	36	0.53	0.69	426	939	100	●	●	●	●	●	●	●	●	●	●	●	●
	312	1050	42	0.65	0.84	479	1,055	100	⊙	●	●	●	⊙	●	●	●	●	●	●	●
	312	1200	48	0.76	1.00	519	1,143	100	⊖	⊙	●	●	⊖	⊙	●	●	●	●	●	●
Heavy Duty (HD)	312	450	18	0.20	0.27	289	637	100	●	●	●	●	●	●	●	●	●	●	●	
	312	1200	1071	0.76	0.99	533	1,174	100	⊖	⊙	●	●	⊖	⊙	●	●	●	●	●	
Severe Duty (SD)	312	900	36	0.53	0.69	475	1,047	90	●	●	●	●	●	●	●	●	●	●	●	
Ditch Cleaning (DC)	312	1800	72	0.68	0.89	540	1,191	100	⊙	●	●	●	⊖	⊙	●	●	●	●	●	
	312	1800	71	0.57	0.74	421	928	100	●	●	●	●	●	●	●	●	●	●	●	
Ditch Cleaning Tilt (DCT)	312	1800	72	0.60	0.78	724	1,597	100	⊖	●	●	●	⊖	⊙	●	●	●	●	●	
Maximum load with pin-on (payload + bucket)									kg	1747	1993	3226	3931	1657	1889	3048	3707			
									lb	3,851	4,393	7,113	8,666	3,653	4,165	6,721	8,172			
With Cat Pin Grabber Coupler																				
Utility Duty (UD)	312	600	24	0.31	0.40	327	722	100	●	●	●	●	●	●	●	●	●	●	●	
	312	1200	48	0.76	1.00	515	1,134	100	⊖	⊙	●	●	⊖	⊙	●	●	●	●	●	
General Duty (GD)	312	600	24	0.31	0.40	317	699	100	●	●	●	●	●	●	●	●	●	●	●	
	312	1000	39	0.60	0.78	439	969	100	●	●	●	●	●	●	●	●	●	●	●	
	312	1100	43	0.68	0.89	474	1,046	100	⊙	●	●	●	⊙	●	●	●	●	●	●	
General Duty (GD) – ANZ	312	450	18	0.20	0.26	267	589	100	●	●	●	●	●	●	●	●	●	●	●	
	312	500	20	0.24	0.31	287	633	100	●	●	●	●	●	●	●	●	●	●	●	
	312	750	30	0.41	0.54	358	790	100	●	●	●	●	●	●	●	●	●	●	●	
	312	900	36	0.53	0.69	426	939	100	●	●	●	●	●	●	●	●	●	●	●	
	312	1050	42	0.65	0.84	479	1,055	100	⊙	●	●	●	⊙	●	●	●	●	●	●	
	312	1200	48	0.76	1.00	519	1,143	100	⊖	⊙	●	●	⊖	⊙	●	●	●	●	●	
Heavy Duty (HD)	312	450	18	0.20	0.27	289	637	100	●	●	●	●	●	●	●	●	●	●	●	
	312	1200	1071	0.76	0.99	533	1,174	100	⊖	⊙	●	●	⊖	⊙	●	●	●	●	●	
Severe Duty (SD)	312	900	36	0.53	0.69	475	1,047	90	●	●	●	●	●	●	●	●	●	●	●	
Ditch Cleaning (DC)	312	1800	72	0.68	0.89	540	1,191	100	⊙	●	●	●	⊖	⊙	●	●	●	●	●	
	312	1800	71	0.57	0.74	421	928	100	●	●	●	●	●	●	●	●	●	●	●	
Maximum load with coupler (payload + bucket)									kg	1547	1793	3027	3731	1457	1689	2849	3507			
									lb	3,411	3,953	6,673	8,225	3,213	3,724	6,280	7,732			

The above loads are in compliance with hydraulic excavator standard EN474-5:2006+A3:2013, they do not exceed 87% of hydraulic lifting capacity or 75% of tipping capacity with front linkage fully extended at ground line with bucket curled. Capacity based on ISO 7451:2007.

Maximum Material Density:

- 2100 kg/m³ (3,500 lb/yd³)
- ⊙ 1800 kg/m³ (3,000 lb/yd³)
- ⊖ 1500 kg/m³ (2,500 lb/yd³)

Caterpillar recommends using appropriate work tools to maximize the value customers receive from our products. Use of work tools, including buckets, which are outside of Caterpillar's recommendations or specifications for weight, dimensions, flows, pressures, etc. may result in less-than-optimal performance, including but not limited to reductions in production, stability, reliability, and component durability. Improper use of a work tool resulting in sweeping, prying, twisting and/or catching of heavy loads will reduce the life of the boom and stick.

(continued on next page)

M314 Wheeled Excavator Specifications

Bucket Specifications and Compatibility – Europe (continued)

Contact your Cat dealer for special bucket requirements.

	Linkage	Width		Capacity		Weight		Fill	3300 kg (7,280 lb) Counterweight									
		4650 mm (15'3") One-Piece Boom								2200 mm (7'3") Stick				2500 mm (8'2") Stick				
		mm	in	m ³	yd ³	kg	lb		%	Free on wheels	Rear dozer blade lowered	Front dozer and rear stabilizer lowered	Four stabilizers lowered	Free on wheels	Rear dozer blade lowered	Front dozer and rear stabilizer lowered	Four stabilizers lowered	
With CW20 Coupler																		
General Duty (GD)	CW20	600	24	0.31	0.40	344	758	100	●	●	●	●	●	●	●	●	●	
	CW20	900	36	0.53	0.69	426	940	100	●	●	●	●	⊙	●	●	●	●	
	CW20	1100	43	0.68	0.89	487	1,073	100	⊖	⊙	●	●	⊖	⊙	●	●	●	
Heavy Duty (HD)	CW20	1200	48	0.76	1.00	526	1,159	100	○	⊖	●	●	○	⊖	●	●	●	
General Duty (GD) Leveling Edge	CW20	690	27	0.40	0.52	410	904	100	●	●	●	●	●	●	●	●	●	
	CW20	790	31	0.47	0.61	452	997	100	●	●	●	●	●	●	●	●	●	
	CW20	996	39	0.63	0.83	515	1,135	100	⊖	●	●	●	⊖	⊙	●	●	●	
	CW20	1184	47	0.80	1.05	601	1,324	100	○	⊖	●	●	◇	○	●	●	●	
Ditch Cleaning (DC)	CW20	1800	72	0.68	0.89	516	1,138	100	⊖	⊙	●	●	○	⊙	●	●	●	
	CW20	1800	72	0.90	1.18	554	1,221	100	◇	○	●	●	◇	○	●	●	●	
Maximum load with coupler (payload + bucket)									kg	1542	1788	3021	3726	1452	1684	2843	3502	
									lb	3,399	3,942	6,661	8,214	3,201	3,713	6,269	7,720	
With CW20S Coupler																		
General Duty (GD)	CW20S	450	18	0.20	0.26	302	666	100	●	●	●	●	●	●	●	●	●	
	CW20S	500	20	0.24	0.31	311	686	100	●	●	●	●	●	●	●	●	●	
	CW20S	600	24	0.31	0.40	330	728	100	●	●	●	●	●	●	●	●	●	
	CW20S	750	30	0.41	0.54	377	832	100	●	●	●	●	●	●	●	●	●	
	CW20S	900	36	0.53	0.69	426	940	100	●	●	●	●	⊙	●	●	●	●	
	CW20S	1000	39	0.60	0.78	451	995	100	⊙	●	●	●	⊖	●	●	●	●	
	CW20S	1100	43	0.68	0.89	487	1,073	100	⊖	⊙	●	●	⊖	⊙	●	●	●	
Heavy Duty (HD)	CW20S	1200	48	0.76	1.00	516	1,137	100	○	⊖	●	●	○	⊖	●	●	●	
	CW20S	500	20	0.24	0.31	321	708	100	●	●	●	●	●	●	●	●	●	
Ditch Cleaning (DC)	CW20S	1200	48	0.76	1.00	526	1,160	100	○	⊖	●	●	○	⊖	●	●	●	
	CW20S	1800	72	0.68	0.89	457	1,008	100	⊖	⊙	●	●	⊖	⊙	●	●	●	
Ditch Cleaning Tilt (DCT)	CW20S	2000	78	1.00	1.31	531	1,171	100	◇	○	●	●	◇	○	●	●	●	
	CW20S	1800	72	0.60	0.78	732	1,614	100	○	⊙	●	●	○	⊖	●	●	●	
Maximum load with coupler (payload + bucket)									kg	1564	1810	3043	3748	1474	1706	2865	3524	
									lb	3,448	3,990	6,710	8,262	3,250	3,761	6,317	7,769	
Pin-On, TRS10 CW20																		
Grading – General Duty	312	1600	63	0.76	0.99	571	1,259	100	X	○	●	●	X	◇	●	●	●	
Maximum load with pin-on (payload + bucket)									kg	1202	1448	2681	3386	1112	1344	2503	3162	
									lb	2,650	3,192	5,912	7,464	2,452	2,963	5,519	6,971	

Maximum Material Density:

- 2100 kg/m³ (3,500 lb/yd³)
- ⊙ 1800 kg/m³ (3,000 lb/yd³)
- ⊖ 1500 kg/m³ (2,500 lb/yd³)
- 1200 kg/m³ (2,000 lb/yd³)
- ◇ 900 kg/m³ (1,500 lb/yd³)
- X Not Recommended

The above loads are in compliance with hydraulic excavator standard EN474-5:2006+A3:2013, they do not exceed 87% of hydraulic lifting capacity or 75% of tipping capacity with front linkage fully extended at ground line with bucket curled. Capacity based on ISO 7451:2007.

Caterpillar recommends using appropriate work tools to maximize the value customers receive from our products. Use of work tools, including buckets, which are outside of Caterpillar's recommendations or specifications for weight, dimensions, flows, pressures, etc. may result in less-than-optimal performance, including but not limited to reductions in production, stability, reliability, and component durability. Improper use of a work tool resulting in sweeping, prying, twisting and/or catching of heavy loads will reduce the life of the boom and stick.

(continued on next page)

M314 Wheeled Excavator Specifications

Bucket Specifications and Compatibility – Europe (continued)

Contact your Cat dealer for special bucket requirements.

	Linkage	Width		Capacity		Weight		Fill	3300 kg (7,280 lb) Counterweight							
									4650 mm (15'3") One-Piece Boom							
									2200 mm (7'3") Stick				2500 mm (8'2") Stick			
		mm	in	m ³	yd ³	kg	lb		Free on wheels	Rear dozer blade lowered	Front dozer and rear stabilizer lowered	Four stabilizers lowered	Free on wheels	Rear dozer blade lowered	Front dozer and rear stabilizer lowered	Four stabilizers lowered
Pin-On, TRS10 CW20S																
Grading – General Duty	312	1500	59	0.65	0.85	528	1,164	100	◇	○	●	●	◇	○	●	●
Trenching – General Duty	312	540	21	0.37	0.48	336	740	100	●	●	●	●	●	●	●	●
								kg	1191	1437	2670	3375	1101	1333	2492	3151
								lb	2,625	3,168	5,887	7,440	2,428	2,939	5,495	6,946
Pin-On, TRS10 S60																
Grading – Heavy Duty	312	1500	59	0.52	0.68	511	1,127	100	⊖	●	●	●	○	⊕	●	●
	312	1500	59	0.65	0.85	535	1,179	100	○	⊖	●	●	◇	⊖	●	●
	312	1600	63	0.75	0.98	576	1,270	100	◇	○	●	●	◇	○	●	●
Trenching – Heavy Duty	312	540	21	0.33	0.43	320	706	100	●	●	●	●	●	●	●	●
								kg	1320	1566	2799	3504	1230	1462	2621	3280
								lb	2,910	3,452	6,172	7,724	2,712	3,223	5,779	7,231
With CW20S, TRS10 CW20S																
Grading – Heavy Duty	312	1500	59	0.65	0.85	528	1,164	100	X	◇	●	●	X	◇	●	●
Trenching – Heavy Duty	312	540	21	0.37	0.48	336	740	100	⊕	●	●	●	⊖	●	●	●
								kg	998	1244	2477	3182	908	1140	2299	2958
								lb	2,200	2,742	5,462	7,014	2,002	2,513	5,069	6,521
With S60, TRS10 S60																
Grading – Heavy Duty	312	1500	59	0.52	0.68	511	1,127	100	○	⊕	●	●	◇	⊖	●	●
	312	1500	59	0.65	0.85	535	1,179	100	◇	○	●	●	X	○	●	●
	312	1600	63	0.75	0.98	576	1,270	100	X	◇	●	●	X	◇	●	●
Trenching – Heavy Duty	312	540	21	0.33	0.43	320	706	100	●	●	●	●	●	●	●	●
								kg	1160	1406	2639	3344	1070	1302	2461	3120
								lb	2,557	3,099	5,819	7,371	2,359	2,871	5,427	6,878

Maximum Material Density:

- 2100 kg/m³ (3,500 lb/yd³)
- ⊕ 1800 kg/m³ (3,000 lb/yd³)
- ⊖ 1500 kg/m³ (2,500 lb/yd³)
- 1200 kg/m³ (2,000 lb/yd³)
- ◇ 900 kg/m³ (1,500 lb/yd³)
- X Not Recommended

The above loads are in compliance with hydraulic excavator standard EN474-5:2006+A3:2013, they do not exceed 87% of hydraulic lifting capacity or 75% of tipping capacity with front linkage fully extended at ground line with bucket curled.

Capacity based on ISO 7451:2007.

Caterpillar recommends using appropriate work tools to maximize the value customers receive from our products. Use of work tools, including buckets, which are outside of Caterpillar's recommendations or specifications for weight, dimensions, flows, pressures, etc. may result in less-than-optimal performance, including but not limited to reductions in production, stability, reliability, and component durability. Improper use of a work tool resulting in sweeping, prying, twisting and/or catching of heavy loads will reduce the life of the boom and stick.

M314 Wheeled Excavator Specifications

Bucket Specifications and Compatibility – Australia and New Zealand

Contact your Cat dealer for special bucket requirements.

Linkage	Width		Capacity		Weight		Fill	3300 kg (7,280 lb) Counterweight											
								Variable Adjustable Boom											
								2200 mm (7'3") Stick				2500 mm (8'2") Stick							
								Free on wheels	Rear dozer blade lowered	Front dozer and rear stabilizer lowered	Four stabilizers lowered	Free on wheels	Rear dozer blade lowered	Front dozer and rear stabilizer lowered	Four stabilizers lowered				
Pin-On (No Quick Coupler)																			
General Duty (GD) (No Adjuster)	312	450	18	0.20	0.26	267	589	100	●	●	●	●	●	●	●	●	●		
	312	500	20	0.24	0.31	287	633	100	●	●	●	●	●	●	●	●	●		
	312	600	24	0.31	0.40	310	684	100	●	●	●	●	●	●	●	●	●		
	312	750	30	0.41	0.54	358	790	100	●	●	●	●	●	●	●	●	●		
	312	750	30	0.41	0.54	413	911	100	●	●	●	●	●	●	●	●	●		
	312	900	36	0.53	0.69	426	939	100	⊙	●	●	●	⊙	●	●	●	●		
	312	900	36	0.53	0.69	454	1,001	100	⊙	●	●	●	⊙	●	●	●	●		
	312	1050	42	0.65	0.84	479	1,055	100	⊖	⊙	●	●	⊖	⊙	●	●	●		
Ditch Cleaning Tilt (DCT)	312	1500	60	0.74	0.98	704	1,553	100	◇	○	●	●	◇	○	●	●	●		
	312	1800	72	0.90	1.18	784	1,728	100	X	◇	●	●	X	◇	●	●	●		
Maximum load with pin-on (payload + bucket)								kg	1468	1696	2826	3465	1396	1612	2679	3280			
								lb	3,237	3,740	6,230	7,638	3,077	3,554	5,906	7,230			
With Cat Pin Grabber Coupler																			
General Duty (GD) (No Adjuster)	312	450	18	0.20	0.26	267	589	100	●	●	●	●	●	●	●	●	●		
	312	500	20	0.24	0.31	287	633	100	●	●	●	●	●	●	●	●	●		
	312	600	24	0.31	0.40	310	684	100	●	●	●	●	●	●	●	●	●		
	312	750	30	0.41	0.54	358	790	100	●	●	●	●	●	●	●	●	●		
	312	750	30	0.41	0.54	413	911	100	●	●	●	●	●	●	●	●	●		
	312	900	36	0.53	0.69	426	939	100	⊙	●	●	●	⊙	●	●	●	●		
	312	900	36	0.53	0.69	454	1,001	100	⊙	●	●	●	⊙	●	●	●	●		
	312	1050	42	0.65	0.84	479	1,055	100	⊖	⊙	●	●	⊖	⊙	●	●	●		
Ditch Cleaning Tilt (DCT)	312	1500	60	0.74	0.98	704	1,553	100	◇	○	●	●	◇	○	●	●	●		
	312	1800	72	0.90	1.18	784	1,728	100	X	◇	●	●	X	◇	●	●	●		
Maximum load with coupler (payload + bucket)								kg	1268	1497	2626	3265	1196	1412	2479	3080			
								lb	2,796	3,299	5,790	7,198	2,637	3,113	5,466	6,790			

Maximum Material Density:

- 2100 kg/m³ (3,500 lb/yd³)
- ⊙ 1800 kg/m³ (3,000 lb/yd³)
- ⊖ 1500 kg/m³ (2,500 lb/yd³)
- 1200 kg/m³ (2,000 lb/yd³)
- ◇ 900 kg/m³ (1,500 lb/yd³)
- X Not Recommended

The above loads are in compliance with hydraulic excavator standard EN474-5:2006+A3:2013, they do not exceed 87% of hydraulic lifting capacity or 75% of tipping capacity with front linkage fully extended at ground line with bucket curled. Capacity based on ISO 7451:2007.

Caterpillar recommends using appropriate work tools to maximize the value customers receive from our products. Use of work tools, including buckets, which are outside of Caterpillar's recommendations or specifications for weight, dimensions, flows, pressures, etc. may result in less-than-optimal performance, including but not limited to reductions in production, stability, reliability, and component durability. Improper use of a work tool resulting in sweeping, prying, twisting and/or catching of heavy loads will reduce the life of the boom and stick.

(continued on next page)

M314 Wheeled Excavator Specifications

Bucket Specifications and Compatibility – Australia and New Zealand (continued)

Contact your Cat dealer for special bucket requirements.

Linkage	Width		Capacity		Weight		Fill	3300 kg (7,280 lb) Counterweight								
								4650 mm (15'3") One-Piece Boom								
								2200 mm (7'3") Stick				2500 mm (8'2") Stick				
								Free on wheels	Rear dozer blade lowered	Front dozer and rear stabilizer lowered	Four stabilizers lowered	Free on wheels	Rear dozer blade lowered	Front dozer and rear stabilizer lowered	Four stabilizers lowered	
mm	in	m ³	yd ³	kg	lb	%										
Pin-On (No Quick Coupler)																
General Duty (GD) – ANZ	312	450	18	0.20	0.26	267	589	100	●	●	●	●	●	●	●	●
	312	500	20	0.24	0.31	287	633	100	●	●	●	●	●	●	●	●
	312	600	24	0.31	0.40	310	684	100	●	●	●	●	●	●	●	●
	312	750	30	0.41	0.54	358	790	100	●	●	●	●	●	●	●	●
	312	750	30	0.41	0.54	413	911	100	●	●	●	●	●	●	●	●
	312	900	36	0.53	0.69	426	939	100	●	●	●	●	●	●	●	●
	312	900	36	0.53	0.69	454	1,001	100	●	●	●	●	●	●	●	●
	312	1050	42	0.65	0.84	479	1,055	100	⊙	●	●	●	⊙	●	●	●
Ditch Cleaning Tilt (DCT)	312	1500	60	0.74	0.98	704	1,553	100	○	⊙	●	●	○	⊖	●	●
	312	1800	72	0.90	1.18	784	1,728	100	◇	○	●	●	◇	○	●	●
Maximum load with pin-on (payload + bucket)								kg	1747	1993	3226	3931	1657	1889	3048	3707
								lb	3,851	4,393	7,113	8,666	3,653	4,165	6,721	8,172
With Cat Pin Grabber Coupler																
General Duty (GD) – ANZ	312	450	18	0.20	0.26	267	589	100	●	●	●	●	●	●	●	●
	312	500	20	0.24	0.31	287	633	100	●	●	●	●	●	●	●	●
	312	600	24	0.31	0.40	310	684	100	●	●	●	●	●	●	●	●
	312	750	30	0.41	0.54	358	790	100	●	●	●	●	●	●	●	●
	312	750	30	0.41	0.54	413	911	100	●	●	●	●	●	●	●	●
	312	900	36	0.53	0.69	426	939	100	●	●	●	●	●	●	●	●
	312	900	36	0.53	0.69	454	1,001	100	●	●	●	●	●	●	●	●
	312	1050	42	0.65	0.84	479	1,055	100	⊙	●	●	●	⊙	●	●	●
Ditch Cleaning Tilt (DCT)	312	1500	60	0.74	0.98	704	1,553	100	○	⊙	●	●	○	⊖	●	●
	312	1800	72	0.90	1.18	784	1,728	100	◇	○	●	●	◇	○	●	●
Maximum load with coupler (payload + bucket)								kg	1547	1793	3027	3731	1457	1689	2849	3507
								lb	3,411	3,953	6,673	8,225	3,213	3,724	6,280	7,732

Maximum Material Density:

- 2100 kg/m³ (3,500 lb/yd³)
- ⊙ 1800 kg/m³ (3,000 lb/yd³)
- ⊖ 1500 kg/m³ (2,500 lb/yd³)
- 1200 kg/m³ (2,000 lb/yd³)
- ◇ 900 kg/m³ (1,500 lb/yd³)

The above loads are in compliance with hydraulic excavator standard EN474-5:2006+A3:2013, they do not exceed 87% of hydraulic lifting capacity or 75% of tipping capacity with front linkage fully extended at ground line with bucket curled. Capacity based on ISO 7451:2007.

Caterpillar recommends using appropriate work tools to maximize the value customers receive from our products. Use of work tools, including buckets, which are outside of Caterpillar's recommendations or specifications for weight, dimensions, flows, pressures, etc. may result in less-than-optimal performance, including but not limited to reductions in production, stability, reliability, and component durability. Improper use of a work tool resulting in sweeping, prying, twisting and/or catching of heavy loads will reduce the life of the boom and stick.

M314 Wheeled Excavator Specifications

Bucket Specifications and Compatibility – South Korea

Contact your Cat dealer for special bucket requirements.

	Linkage	Width		Capacity		Weight		Fill	3300 kg (7,280 lb) Counterweight								
		Variable Adjustable Boom							2200 mm (7'3") Stick				2500 mm (8'2") Stick				
		mm	in	m ³	yd ³	kg	lb		%	Free on wheels	Rear dozer blade lowered	Front dozer and rear stabilizer lowered	Four stabilizers lowered	Free on wheels	Rear dozer blade lowered	Front dozer and rear stabilizer lowered	Four stabilizers lowered
Pin-On (No Quick Coupler)																	
General Duty (GD)	312	450	18	0.20	0.27	278	614	100	●	●	●	●	●	●	●	●	
	312	600	24	0.31	0.40	317	699	100	●	●	●	●	●	●	●	●	
	312	1000	39	0.60	0.78	439	969	100	⊙	●	●	●	⊖	⊙	●	●	
	312	1200	48	0.76	1.00	504	1,110	100	○	⊖	●	●	○	⊖	●	●	
Severe Duty (SD)	312	1050	42	0.65	0.85	554	1,221	90	⊖	⊙	●	●	⊖	⊙	●	●	
Maximum load with pin-on (payload + bucket)									kg	1468	1696	2826	3465	1396	1612	2679	3280
									lb	3,237	3,740	6,230	7,638	3,077	3,554	5,906	7,230
With Cat Pin Grabber Coupler																	
General Duty (GD)	312	450	18	0.20	0.27	278	614	100	●	●	●	●	●	●	●	●	
	312	600	24	0.31	0.40	317	699	100	●	●	●	●	●	●	●	●	
	312	1000	39	0.60	0.78	439	969	100	⊙	●	●	●	⊖	⊙	●	●	
	312	1200	48	0.76	1.00	504	1,110	100	○	⊖	●	●	○	⊖	●	●	
Severe Duty (SD)	312	1050	42	0.65	0.85	554	1,221	100	○	⊙	●	●	○	⊖	●	●	
Maximum load with coupler (payload + bucket)									kg	1268	1497	2626	3265	1196	1412	2479	3080
									lb	2,796	3,299	5,790	7,198	2,637	3,113	5,466	6,790

Maximum Material Density:

- 2100 kg/m³ (3,500 lb/yd³)
- ⊙ 1800 kg/m³ (3,000 lb/yd³)
- ⊖ 1500 kg/m³ (2,500 lb/yd³)
- 1200 kg/m³ (2,000 lb/yd³)

The above loads are in compliance with hydraulic excavator standard EN474-5:2006+A3:2013, they do not exceed 87% of hydraulic lifting capacity or 75% of tipping capacity with front linkage fully extended at ground line with bucket curled. Capacity based on ISO 7451:2007.

Caterpillar recommends using appropriate work tools to maximize the value customers receive from our products. Use of work tools, including buckets, which are outside of Caterpillar's recommendations or specifications for weight, dimensions, flows, pressures, etc. may result in less-than-optimal performance, including but not limited to reductions in production, stability, reliability, and component durability. Improper use of a work tool resulting in sweeping, prying, twisting and/or catching of heavy loads will reduce the life of the boom and stick.

(continued on next page)

M314 Wheeled Excavator Specifications

Bucket Specifications and Compatibility – South Korea (continued)

Contact your Cat dealer for special bucket requirements.

	Linkage	Width		Capacity		Weight		Fill	3300 kg (7,280 lb) Counterweight								
		4400 mm (14'5") One-Piece Boom							2200 mm (7'3") Stick				2500 mm (8'2") Stick				
		mm	in	m ³	yd ³	kg	lb		%	Free on wheels	Rear dozer blade lowered	Front dozer and rear stabilizer lowered	Four stabilizers lowered	Free on wheels	Rear dozer blade lowered	Front dozer and rear stabilizer lowered	Four stabilizers lowered
Pin-On (No Quick Coupler)																	
General Duty (GD)	312	450	18	0.20	0.27	278	614	100	●	●	●	●	●	●	●	●	●
	312	600	24	0.31	0.40	317	699	100	●	●	●	●	●	●	●	●	●
	312	1000	39	0.60	0.78	439	969	100	●	●	●	●	●	●	●	●	●
	312	1200	48	0.76	1.00	504	1,110	100	⊙	●	●	●	●	⊖	⊙	●	●
Severe Duty (SD) – CCL	312	1050	42	0.65	0.85	554	1,221	90	●	●	●	●	●	●	●	●	●
									kg	1856	2113	3414	4162	1757	1998	3216	3913
									lb	4,091	4,658	7,526	9,176	3,873	4,406	7,091	8,628
With Cat Pin Grabber Coupler																	
General Duty (GD)	312	450	18	0.20	0.27	278	614	100	●	●	●	●	●	●	●	●	●
	312	600	24	0.31	0.40	317	699	100	●	●	●	●	●	●	●	●	●
	312	1000	39	0.60	0.78	439	969	100	●	●	●	●	●	●	●	●	●
	312	1200	48	0.76	1.00	504	1,110	100	⊙	●	●	●	●	⊖	⊙	●	●
Severe Duty (SD) – CCL	312	1050	42	0.65	0.85	554	1,221	100	●	●	●	●	⊖	⊙	●	●	●
									kg	1656	1913	3214	3963	1557	1799	3017	3714
									lb	3,651	4,218	7,086	8,736	3,432	3,965	6,651	8,187

The above loads are in compliance with hydraulic excavator standard EN474-5:2006+A3:2013, they do not exceed 87% of hydraulic lifting capacity or 75% of tipping capacity with front linkage fully extended at ground line with bucket curled. Capacity based on ISO 7451:2007.

Maximum Material Density:

- 2100 kg/m³ (3,500 lb/yd³)
- ⊙ 1800 kg/m³ (3,000 lb/yd³)
- ⊖ 1500 kg/m³ (2,500 lb/yd³)

Caterpillar recommends using appropriate work tools to maximize the value customers receive from our products. Use of work tools, including buckets, which are outside of Caterpillar's recommendations or specifications for weight, dimensions, flows, pressures, etc. may result in less-than-optimal performance, including but not limited to reductions in production, stability, reliability, and component durability. Improper use of a work tool resulting in sweeping, prying, twisting and/or catching of heavy loads will reduce the life of the boom and stick.

M314 Wheeled Excavator Specifications

Attachments Offering Guide – North America

Not all Attachments are available in all regions. Consult your Cat dealer for configurations available in your region.

Match
 * Working range front only
 No Match
 1800 kg/m³ (3,000 lb/yd³)
 1200 kg/m³ (2,000 lb/yd³)

PIN-ON ATTACHMENTS

Undercarriage		Front Blade; Rear Outriggers		Front Outriggers; Rear Blade		Front and Rear Outriggers		Rear Blade	
		3300 kg (7,280 lb)		3300 kg (7,280 lb)		3300 kg (7,280 lb)		3300 kg (7,280 lb)	
Counterweight		Variable Adjustable		Variable Adjustable		Variable Adjustable		Variable Adjustable	
Boom Type		Variable Adjustable		Variable Adjustable		Variable Adjustable		Variable Adjustable	
Stick Length		2.20 m (7'3")	2.50 m (8'2")	2.20 m (7'3")	2.50 m (8'2")	2.20 m (7'3")	2.50 m (8'2")	2.20 m (7'3")	2.50 m (8'2")
Hydraulic Hammers	H110 GC S	✓	✓	✓	✓	✓	✓	✓	✓
	H110 S	✓	✓	✓	✓	✓	✓	✓	✓
	H115 GC S	✓	✓	✓	✓	✓	✓	✓	✓
	H115 S	✓	✓	✓	✓	✓	✓	✓	✓
Demolition and Sorting Grapples	G314	✓	✓	✓	✓	✓	✓	✓*	✓*
Mulchers	HM2615	✓	✓	✓	✓	✓	✓	✓	✓
	HM3013	✓	✓	✓	✓	✓	✓	✓	✓
Compactors (Vibratory Plate)	CVP75	✓	✓	✓	✓	✓	✓	✓	✓
Orange Peel Grapples	GSH420-500	●	●	●	●	●	●		
	GSH420-600	●	●	●	●	●	●		
	GSH420-750	●	○	○	○	●	○		
	GSH520-500	●	●	●	●	●	●		
	GSH520-600	●	○	●	○	●	○		
	GSH520-750	○	○	○	○	○	○		

CAT PIN GRABBER COUPLER ATTACHMENTS

Undercarriage		Front Blade; Rear Outriggers		Front Outriggers; Rear Blade		Front and Rear Outriggers		Rear Blade	
		3300 kg (7,280 lb)		3300 kg (7,280 lb)		3300 kg (7,280 lb)		3300 kg (7,280 lb)	
Counterweight		Variable Adjustable		Variable Adjustable		Variable Adjustable		Variable Adjustable	
Boom Type		Variable Adjustable		Variable Adjustable		Variable Adjustable		Variable Adjustable	
Stick Length		2.20 m (7'3")	2.50 m (8'2")	2.20 m (7'3")	2.50 m (8'2")	2.20 m (7'3")	2.50 m (8'2")	2.20 m (7'3")	2.50 m (8'2")
Hydraulic Hammers	H110 GC S	✓	✓	✓	✓	✓	✓	✓	✓
	H110 S	✓	✓	✓	✓	✓	✓	✓	✓
	H115 GC S	✓	✓	✓	✓	✓	✓	✓	✓*
	H115 S	✓	✓	✓	✓	✓	✓	✓	✓
Mulchers	HM2615	✓	✓	✓	✓	✓	✓	✓	✓
	HM3013	✓	✓	✓	✓	✓	✓	✓*	
Compactors (Vibratory Plate)	CVP75	✓	✓	✓	✓	✓	✓	✓	✓

(continued on next page)

M314 Wheeled Excavator Specifications

Attachments Offering Guide – North America (continued)

Not all Attachments are available in all regions. Consult your Cat dealer for configurations available in your region.

Match No Match

S60 DEDICATED COUPLER ATTACHMENTS

Undercarriage		Front Blade; Rear Outriggers		Front Outriggers; Rear Blade		Front and Rear Outriggers		Rear Blade	
		3300 kg (7,280 lb)		3300 kg (7,280 lb)		3300 kg (7,280 lb)		3300 kg (7,280 lb)	
Counterweight		Variable Adjustable		Variable Adjustable		Variable Adjustable		Variable Adjustable	
Boom Type		2.20 m (7'3")		2.50 m (8'2")		2.20 m (7'3")		2.50 m (8'2")	
Stick Length		2.20 m (7'3")		2.50 m (8'2")		2.20 m (7'3")		2.50 m (8'2")	
Hydraulic Hammers	H110 GC S	✓	✓	✓	✓	✓	✓	✓	✓
	H110 S	✓	✓	✓	✓	✓	✓	✓	✓
	H115 GC S	✓	✓	✓	✓	✓	✓	✓	✓
	H115 S	✓	✓	✓	✓	✓	✓	✓	✓
Demolition and Sorting Grapples	G314	✓	✓	✓	✓	✓	✓		
Mobile Scrap and Demolition Shears	S3015 Flat Top	✓	✓	✓	✓	✓	✓		
Compactors (Vibratory Plate)	CVP75	✓	✓	✓	✓	✓	✓	✓	✓

HCS60 DEDICATED COUPLER ATTACHMENTS

Undercarriage		Front Blade; Rear Outriggers		Front Outriggers; Rear Blade		Front and Rear Outriggers		Rear Blade	
		3300 kg (7,280 lb)		3300 kg (7,280 lb)		3300 kg (7,280 lb)		3300 kg (7,280 lb)	
Counterweight		Variable Adjustable		Variable Adjustable		Variable Adjustable		Variable Adjustable	
Boom Type		2.20 m (7'3")		2.50 m (8'2")		2.20 m (7'3")		2.50 m (8'2")	
Stick Length		2.20 m (7'3")		2.50 m (8'2")		2.20 m (7'3")		2.50 m (8'2")	
Hydraulic Hammers	H110 S	✓	✓	✓	✓	✓	✓	✓	✓
	H115 S	✓	✓	✓	✓	✓	✓	✓	✓
Demolition and Sorting Grapples	G314	✓	✓	✓	✓	✓	✓		
Mobile Scrap and Demolition Shears	S3015 Flat Top	✓		✓		✓			
Compactors (Vibratory Plate)	CVP75	✓	✓	✓	✓	✓	✓	✓	✓

(continued on next page)

M314 Wheeled Excavator Specifications

Attachments Offering Guide – North America (continued)

Not all Attachments are available in all regions. Consult your Cat dealer for configurations available in your region.

Match

* Working range front only

No Match

HCS65 DEDICATED COUPLER ATTACHMENTS

Undercarriage		Front Blade; Rear Outriggers		Front Outriggers; Rear Blade		Front and Rear Outriggers		Rear Blade	
		3300 kg (7,280 lb)	3300 kg (7,280 lb)	3300 kg (7,280 lb)	3300 kg (7,280 lb)	3300 kg (7,280 lb)	3300 kg (7,280 lb)		
Counterweight		Variable Adjustable		Variable Adjustable		Variable Adjustable		Variable Adjustable	
Boom Type		2.20 m (7'3")	2.50 m (8'2")	2.20 m (7'3")	2.50 m (8'2")	2.20 m (7'3")	2.50 m (8'2")	2.20 m (7'3")	2.50 m (8'2")
Hydraulic Hammers	H110 S	✓	✓	✓	✓	✓	✓	✓	✓
	H115 S	✓	✓	✓	✓	✓	✓	✓	✓
Demolition and Sorting Grapples	G314	✓		✓		✓			
Compactors (Vibratory Plate)	CVP75	✓	✓	✓	✓	✓	✓	✓	✓

TRS10 (PIN-ON TOP/S60 BOTTOM) ATTACHMENTS

Some attachments require more hydraulic flow and are best suited with a machine that has HP2 circuits and a tiltrotator with a high flow swivel. Check the hydraulic capability of your machine and tiltrotator and the requirements of your attachment to ensure a proper match.

Undercarriage		Front Blade; Rear Outriggers		Front Outriggers; Rear Blade		Front and Rear Outriggers		Rear Blade	
		3300 kg (7,280 lb)	3300 kg (7,280 lb)	3300 kg (7,280 lb)	3300 kg (7,280 lb)	3300 kg (7,280 lb)	3300 kg (7,280 lb)		
Counterweight		Variable Adjustable		Variable Adjustable		Variable Adjustable		Variable Adjustable	
Boom Type		2.20 m (7'3")	2.50 m (8'2")	2.20 m (7'3")	2.50 m (8'2")	2.20 m (7'3")	2.50 m (8'2")	2.20 m (7'3")	2.50 m (8'2")
Hydraulic Hammers	H110 GC S	✓	✓	✓	✓	✓	✓	✓*	✓*
	H110 S	✓	✓	✓	✓	✓	✓	✓	✓*
Compactors (Vibratory Plate)	CVP75	✓	✓	✓	✓	✓	✓	✓	✓

NOTE: Use hammers on tiltrotators less than 10% of working hours per year or maximum 200 hours per year. Refer to your Operation and Maintenance Manual for recommended hydraulic flow requirements.

TRS10 (S60 TOP/S60 BOTTOM) ATTACHMENTS

Some attachments require more hydraulic flow and are best suited with a machine that has HP2 circuits and a tiltrotator with a high flow swivel. Check the hydraulic capability of your machine and tiltrotator and the requirements of your attachment to ensure a proper match.

Undercarriage		Front Blade; Rear Outriggers		Front Outriggers; Rear Blade		Front and Rear Outriggers		Rear Blade	
		3300 kg (7,280 lb)	3300 kg (7,280 lb)	3300 kg (7,280 lb)	3300 kg (7,280 lb)	3300 kg (7,280 lb)	3300 kg (7,280 lb)		
Counterweight		Variable Adjustable		Variable Adjustable		Variable Adjustable		Variable Adjustable	
Boom Type		2.20 m (7'3")	2.50 m (8'2")	2.20 m (7'3")	2.50 m (8'2")	2.20 m (7'3")	2.50 m (8'2")	2.20 m (7'3")	2.50 m (8'2")
Hydraulic Hammers	H110 GC S	✓	✓	✓	✓	✓	✓		
	H110 S	✓	✓	✓	✓	✓	✓		
Compactors (Vibratory Plate)	CVP75	✓	✓	✓	✓	✓	✓	✓	✓*

NOTE: Use hammers on tiltrotators less than 10% of working hours per year or maximum 200 hours per year. Refer to your Operation and Maintenance Manual for recommended hydraulic flow requirements.

(continued on next page)

M314 Wheeled Excavator Specifications

Attachments Offering Guide – North America (continued)

Not all Attachments are available in all regions. Consult your Cat dealer for configurations available in your region.

Match

* Working range front only

No Match

TRS10 (PIN-ON TOP/HCS60 BOTTOM) ATTACHMENTS

Some attachments require more hydraulic flow and are best suited with a machine that has HP2 circuits and a tiltrotator with a high flow swivel. Check the hydraulic capability of your machine and tiltrotator and the requirements of your attachment to ensure a proper match.

Undercarriage		Front Blade; Rear Outriggers		Front Outriggers; Rear Blade		Front and Rear Outriggers		Rear Blade	
Counterweight		3300 kg (7,280 lb)		3300 kg (7,280 lb)		3300 kg (7,280 lb)		3300 kg (7,280 lb)	
Boom Type		Variable Adjustable		Variable Adjustable		Variable Adjustable		Variable Adjustable	
Stick Length		2.20 m (7'3")	2.50 m (8'2")	2.20 m (7'3")	2.50 m (8'2")	2.20 m (7'3")	2.50 m (8'2")	2.20 m (7'3")	2.50 m (8'2")
Hydraulic Hammers	H110 S	✓	✓	✓	✓	✓	✓	✓*	
Compactors (Vibratory Plate)	CVP75	✓	✓	✓	✓	✓	✓	✓	✓

NOTE: Use hammers on tiltrotators less than 10% of working hours per year or maximum 200 hours per year. Refer to your Operation and Maintenance Manual for recommended hydraulic flow requirements.

TRS10 (HCS60 TOP/HCS60 BOTTOM) ATTACHMENTS

Some attachments require more hydraulic flow and are best suited with a machine that has HP2 circuits and a tiltrotator with a high flow swivel. Check the hydraulic capability of your machine and tiltrotator and the requirements of your attachment to ensure a proper match.

Undercarriage		Front Blade; Rear Outriggers		Front Outriggers; Rear Blade		Front and Rear Outriggers		Rear Blade	
Counterweight		3300 kg (7,280 lb)		3300 kg (7,280 lb)		3300 kg (7,280 lb)		3300 kg (7,280 lb)	
Boom Type		Variable Adjustable		Variable Adjustable		Variable Adjustable		Variable Adjustable	
Stick Length		2.20 m (7'3")	2.50 m (8'2")	2.20 m (7'3")	2.50 m (8'2")	2.20 m (7'3")	2.50 m (8'2")	2.20 m (7'3")	
Hydraulic Hammers	H110 S	✓	✓	✓	✓	✓	✓		
Compactors (Vibratory Plate)	CVP75	✓	✓	✓	✓	✓	✓	✓*	

NOTE: Use hammers on tiltrotators less than 10% of working hours per year or maximum 200 hours per year. Refer to your Operation and Maintenance Manual for recommended hydraulic flow requirements.

M314 Wheeled Excavator Specifications

Attachments Offering Guide – Europe

Not all Attachments are available in all regions. Consult your Cat dealer for configurations available in your region.

<input checked="" type="checkbox"/> Match	<input type="checkbox"/> No Match	<input checked="" type="checkbox"/> 1800 kg/m ³ (3,000 lb/yd ³)	<input type="checkbox"/> 1200 kg/m ³ (2,000 lb/yd ³)	<input type="checkbox"/> 600 kg/m ³ (1,000 lb/yd ³)
---	-----------------------------------	---	--	---

PIN-ON ATTACHMENTS

Undercarriage		Front and Rear Outriggers					
Counterweight		3300 kg (7,280 lb)					
Boom Type		Variable Adjustable			4.65 m (15'3") One-Piece		
Stick Length		2.20 m (7'3")	2.50 m (8'2")	2.90 m (9'6")	2.20 m (7'3")	2.50 m (8'2")	2.90 m (9'6")
Hydraulic Hammers	H110 GC S	✓	✓		✓	✓	
	H110 S	✓	✓				
	H115 GC S	✓	✓		✓	✓	
	H115 S	✓	✓				
	G312 GC	✓	✓		✓	✓	
Demolition and Sorting Grapples	G313 GC	✓	✓		✓	✓	
	G314	✓	✓		✓	✓	
Mobile Scrap and Demolition Shears	S3015 Flat Top				✓	✓	
Pulverizers	P214 Secondary Pulverizer				✓	✓	
Compactors (Vibratory Plate)	CVP75	✓	✓		✓	✓	
Orange Peel Grapples	GSH420-500	●	●	●	●	●	●
	GSH420-600	●	●	●	●	●	●
	GSH420-750	●	○	●	●	○	●
	GSH520-500	●	●	●	●	●	●
	GSH520-600	●	○	●	●	○	●
	GSH520-750	○	○	○	○	○	○
	GSV420-400	●	●	●	●	●	●
	GSV420-500	●	●	●	●	●	●
	GSV420-600	●	●	●	●	●	●
	GSV420-750	●	○	●	●	○	●
	GSV420-1250	◇	◇	◇	◇	◇	◇
	GSV520 GC-400	●	●	●	●	●	●
	GSV520 GC-500	●	●	●	●	●	●
	GSV520 GC-600	●	●	●	●	●	●
	GSV520 GC-750	●	○	○	●	○	●
	GSV520 GC-1250	◇	◇	◇	◇	◇	◇
	GSV520-400	●	●	●	●	●	●
	GSV520-500	●	●	●	●	●	●
	GSV520-600	●	●	●	●	●	●
	GSV520-750	●	○	○	●	○	○
GSV520-1250	◇	◇	◇	◇	◇	◇	

(continued on next page)

M314 Wheeled Excavator Specifications

Attachments Offering Guide – Europe (continued)

Not all Attachments are available in all regions. Consult your Cat dealer for configurations available in your region.

Match

No Match

1800 kg/m³
(3,000 lb/yd³)

1200 kg/m³
(2,000 lb/yd³)

600 kg/m³
(1,000 lb/yd³)

PIN-ON ATTACHMENTS (continued)

Undercarriage		Front Blade; Rear Outriggers					
Counterweight		3300 kg (7,280 lb)					
Boom Type		Variable Adjustable			4.65 m (15'3") One-Piece		
Stick Length		2.20 m (7'3")	2.50 m (8'2")	2.90 m (9'6")	2.20 m (7'3")	2.50 m (8'2")	2.90 m (9'6")
Hydraulic Hammers	H110 GC S	✓	✓		✓	✓	
	H110 S	✓	✓				
	H115 GC S	✓	✓		✓	✓	
	H115 S	✓	✓				
	G312 GC	✓	✓		✓	✓	
Demolition and Sorting Grapples	G313 GC	✓	✓		✓	✓	
	G314	✓	✓		✓	✓	
Mobile Scrap and Demolition Shears	S3015 Flat Top				✓	✓	
Pulverizers	P214 Secondary Pulverizer				✓	✓	
Compactors (Vibratory Plate)	CVP75	✓	✓		✓	✓	
Orange Peel Grapples	GSH420-500	●	●	●	●	●	●
	GSH420-600	●	●	●	●	●	●
	GSH420-750	●	○	●	●	○	●
	GSH520-500	●	●	●	●	●	●
	GSH520-600	●	○	●	●	○	●
	GSH520-750	○	○	○	○	○	○
	GSV420-400	●	●	●	●	●	●
	GSV420-500	●	●	●	●	●	●
	GSV420-600	●	●	●	●	●	●
	GSV420-750	●	○	●	●	○	●
	GSV420-1250	◇	◇	◇	◇	◇	◇
	GSV520 GC-400	●	●	●	●	●	●
	GSV520 GC-500	●	●	●	●	●	●
	GSV520 GC-600	●	●	●	●	●	●
	GSV520 GC-750	●	○	○	●	○	●
	GSV520 GC-1250	◇	◇	◇	◇	◇	◇
	GSV520-400	●	●	●	●	●	●
	GSV520-500	●	●	●	●	●	●
	GSV520-600	●	●	●	●	●	●
GSV520-750	○	○	○	●	○	○	
GSV520-1250	◇	◇	◇	◇	◇	◇	

(continued on next page)

M314 Wheeled Excavator Specifications

Attachments Offering Guide – Europe (continued)

Not all Attachments are available in all regions. Consult your Cat dealer for configurations available in your region.

<input checked="" type="checkbox"/> Match	<input type="checkbox"/> No Match	<input checked="" type="checkbox"/> 1800 kg/m ³ (3,000 lb/yd ³)	<input type="checkbox"/> 1200 kg/m ³ (2,000 lb/yd ³)	<input type="checkbox"/> 600 kg/m ³ (1,000 lb/yd ³)
---	-----------------------------------	---	--	---

PIN-ON ATTACHMENTS (continued)

Undercarriage		Front Outriggers; Rear Blade					
Counterweight		3300 kg (7,280 lb)					
Boom Type		Variable Adjustable			4.65 m (15'3") One-Piece		
Stick Length		2.20 m (7'3")	2.50 m (8'2")	2.90 m (9'6")	2.20 m (7'3")	2.50 m (8'2")	2.90 m (9'6")
Hydraulic Hammers	H110 GC S	✓	✓		✓	✓	
	H110 S	✓	✓				
	H115 GC S	✓	✓		✓	✓	
	H115 S	✓	✓				
	G312 GC	✓	✓		✓	✓	
Demolition and Sorting Grapples	G313 GC	✓	✓		✓	✓	
	G314	✓	✓		✓	✓	
Mobile Scrap and Demolition Shears	S3015 Flat Top				✓	✓	
Pulverizers	P214 Secondary Pulverizer				✓	✓	
Compactors (Vibratory Plate)	CVP75	✓	✓		✓	✓	
Orange Peel Grapples	GSH420-500	●	●	●	●	●	●
	GSH420-600	●	●	●	●	●	●
	GSH420-750	○	○	○	●	○	●
	GSH520-500	●	●	●	●	●	●
	GSH520-600	●	○	●	●	○	●
	GSH520-750	○	○	○	○	○	○
	GSV420-400	●	●	●	●	●	●
	GSV420-500	●	●	●	●	●	●
	GSV420-600	●	●	●	●	●	●
	GSV420-750	●	○	●	●	○	●
	GSV420-1250	◇	◇	◇	◇	◇	◇
	GSV520 GC-400	●	●	●	●	●	●
	GSV520 GC-500	●	●	●	●	●	●
	GSV520 GC-600	●	●	●	●	●	●
	GSV520 GC-750	○	○	○	●	○	●
	GSV520 GC-1250	◇	◇	◇	◇	◇	◇
	GSV520-400	●	●	●	●	●	●
	GSV520-500	●	●	●	●	●	●
	GSV520-600	●	●	●	●	●	●
	GSV520-750	○	○	○	●	○	○
GSV520-1250	◇	◇	◇	◇	◇	◇	

(continued on next page)

M314 Wheeled Excavator Specifications

Attachments Offering Guide – Europe (continued)

Not all Attachments are available in all regions. Consult your Cat dealer for configurations available in your region.

Match
 * Working range front only
 No Match
 1800 kg/m³ (3,000 lb/yd³)
 1200 kg/m³ (2,000 lb/yd³)

PIN-ON ATTACHMENTS (continued)

Undercarriage		Rear Blade					
Counterweight		3300 kg (7,280 lb)					
Boom Type		Variable Adjustable			4.65 m (15'3") One-Piece		
Stick Length		2.20 m (7'3")	2.50 m (8'2")	2.90 m (9'6")	2.20 m (7'3")	2.50 m (8'2")	2.90 m (9'6")
Hydraulic Hammers	H110 GC S	✓	✓		✓	✓	
	H110 S	✓	✓				
	H115 GC S	✓	✓		✓	✓	
	H115 S	✓	✓				
	G312 GC	✓	✓		✓	✓	
Demolition and Sorting Grapples	G313 GC	✓	✓*		✓	✓	
	G314	✓*	✓*		✓	✓	
Mobile Scrap and Demolition Shears	S3015 Flat Top				✓	✓	
Pulverizers	P214 Secondary Pulverizer				✓	✓*	
Compactors (Vibratory Plate)	CVP75	✓	✓		✓	✓	
Orange Peel Grapples	GSH420-500				○	○	○
	GSH420-600						○
	GSV420-400	○	○	○	●	●	●
	GSV420-500				○	○	○
	GSV420-600				○		○
	GSV520 GC-400	○		○	●	○	●
	GSV520 GC-500				○	○	○
	GSV520-400				○	○	○
	GSV520-500				○		○

(continued on next page)

M314 Wheeled Excavator Specifications

Attachments Offering Guide – Europe (continued)

Not all Attachments are available in all regions. Consult your Cat dealer for configurations available in your region.

Match

* Working range front only

No Match

CAT PIN GRABBER COUPLER ATTACHMENTS

Undercarriage		Front Blade; Rear Outriggers				Front Outriggers; Rear Blade			
Counterweight		3300 kg (7,280 lb)				3300 kg (7,280 lb)			
Boom Type		Variable Adjustable		4.65 m (15'3") One-Piece		Variable Adjustable		4.65 m (15'3") One-Piece	
Stick Length		2.20 m (7'3")	2.50 m (8'2")	2.20 m (7'3")	2.50 m (8'2")	2.20 m (7'3")	2.50 m (8'2")	2.20 m (7'3")	2.50 m (8'2")
Hydraulic Hammers	H110 GC S	✓	✓	✓	✓	✓	✓	✓	✓
	H110 S	✓	✓			✓	✓		
	H115 GC S	✓	✓	✓	✓	✓	✓	✓	✓
	H115 S	✓	✓			✓	✓		
Demolition and Sorting Grapples	G312 GC	✓	✓	✓	✓	✓	✓	✓	✓
	G313 GC			✓	✓			✓	✓
	G314			✓	✓			✓	✓
Mobile Scrap and Demolition Shears	S3015 Flat Top			✓	✓			✓	✓
Pulverizers	P214 Secondary Pulverizer			✓				✓	
Compactors (Vibratory Plate)	CVP75	✓	✓	✓	✓	✓	✓	✓	✓

CAT PIN GRABBER COUPLER ATTACHMENTS (continued)

Undercarriage		Front and Rear Outriggers				Rear Blade			
Counterweight		3300 kg (7,280 lb)				3300 kg (7,280 lb)			
Boom Type		Variable Adjustable		4.65 m (15'3") One-Piece		Variable Adjustable		4.65 m (15'3") One-Piece	
Stick Length		2.20 m (7'3")	2.50 m (8'2")	2.20 m (7'3")	2.50 m (8'2")	2.20 m (7'3")	2.50 m (8'2")	2.20 m (7'3")	2.50 m (8'2")
Hydraulic Hammers	H110 GC S	✓	✓	✓	✓	✓	✓	✓	✓
	H110 S	✓	✓			✓	✓		
	H115 GC S	✓	✓	✓	✓	✓	✓*	✓	✓
	H115 S	✓	✓			✓	✓		
Demolition and Sorting Grapples	G312 GC	✓	✓	✓	✓	✓*		✓	✓
	G313 GC			✓	✓			✓	✓*
	G314			✓	✓			✓*	
Mobile Scrap and Demolition Shears	S3015 Flat Top			✓	✓			✓*	
Pulverizers	P214 Secondary Pulverizer			✓					
Compactors (Vibratory Plate)	CVP75	✓	✓	✓	✓	✓	✓	✓	✓

(continued on next page)

M314 Wheeled Excavator Specifications

Attachments Offering Guide – Europe (continued)

Not all Attachments are available in all regions. Consult your Cat dealer for configurations available in your region.

Match

* Working range front only

No Match

CW-20s DEDICATED COUPLER ATTACHMENTS

Undercarriage		Front Blade; Rear Outriggers				Front Outriggers; Rear Blade			
Counterweight		3300 kg (7,280 lb)				3300 kg (7,280 lb)			
Boom Type		Variable Adjustable		4.65 m (15'3") One-Piece		Variable Adjustable		4.65 m (15'3") One-Piece	
Stick Length		2.20 m (7'3")	2.50 m (8'2")	2.20 m (7'3")	2.50 m (8'2")	2.20 m (7'3")	2.50 m (8'2")	2.20 m (7'3")	2.50 m (8'2")
Hydraulic Hammers	H110 GC S	✓	✓	✓	✓	✓	✓	✓	✓
	H110 S	✓	✓	✓	✓	✓	✓	✓	✓
	H115 GC S	✓	✓	✓	✓	✓	✓	✓	✓
	H115 S	✓	✓	✓	✓	✓	✓	✓	✓
Demolition and Sorting Grapples	G312 GC	✓	✓	✓	✓	✓	✓	✓	✓
	G313 GC	✓	✓	✓	✓	✓	✓	✓	✓
	G314	✓	✓	✓	✓	✓	✓	✓	✓
Mobile Scrap and Demolition Shears	S3015 Flat Top	✓	✓	✓	✓	✓	✓	✓	✓
Pulverizers	P214 Secondary Pulverizer			✓				✓	
Compactors (Vibratory Plate)	CVP75	✓	✓	✓	✓	✓	✓	✓	✓

CW-20s DEDICATED COUPLER ATTACHMENTS (continued)

Undercarriage		Front and Rear Outriggers				Rear Blade			
Counterweight		3300 kg (7,280 lb)				3300 kg (7,280 lb)			
Boom Type		Variable Adjustable		4.65 m (15'3") One-Piece		Variable Adjustable		4.65 m (15'3") One-Piece	
Stick Length		2.20 m (7'3")	2.50 m (8'2")	2.20 m (7'3")	2.50 m (8'2")	2.20 m (7'3")	2.50 m (8'2")	2.20 m (7'3")	2.50 m (8'2")
Hydraulic Hammers	H110 GC S	✓	✓	✓	✓	✓	✓	✓	✓
	H110 S	✓	✓	✓	✓	✓	✓	✓	✓
	H115 GC S	✓	✓	✓	✓	✓*		✓	✓
	H115 S	✓	✓	✓	✓	✓	✓	✓	✓
Demolition and Sorting Grapples	G312 GC	✓	✓	✓	✓	✓	✓*	✓	✓
	G313 GC	✓	✓	✓	✓			✓	✓
	G314	✓	✓	✓	✓			✓	✓*
Mobile Scrap and Demolition Shears	S3015 Flat Top	✓	✓	✓	✓			✓	✓*
Pulverizers	P214 Secondary Pulverizer			✓					
Compactors (Vibratory Plate)	CVP75	✓	✓	✓	✓	✓	✓	✓	✓

(continued on next page)

M314 Wheeled Excavator Specifications

Attachments Offering Guide – Europe (continued)

Not all Attachments are available in all regions. Consult your Cat dealer for configurations available in your region.

Match

* Working range front only

No Match

CW-20 DEDICATED COUPLER ATTACHMENTS

Undercarriage		Front Blade; Rear Outriggers				Front Outriggers; Rear Blade			
Counterweight		3300 kg (7,280 lb)				3300 kg (7,280 lb)			
Boom Type		Variable Adjustable		4.65 m (15'3") One-Piece		Variable Adjustable		4.65 m (15'3") One-Piece	
Stick Length		2.20 m (7'3")	2.50 m (8'2")	2.20 m (7'3")	2.50 m (8'2")	2.20 m (7'3")	2.50 m (8'2")	2.20 m (7'3")	2.50 m (8'2")
Hydraulic Hammers	H110 GC S	✓	✓	✓	✓	✓	✓	✓	✓
	H110 S	✓	✓	✓	✓	✓	✓	✓	✓
	H115 GC S	✓	✓	✓	✓	✓	✓	✓	✓
	H115 S	✓	✓	✓	✓	✓	✓	✓	✓
Demolition and Sorting Grapples	G312 GC	✓	✓	✓	✓	✓	✓	✓	✓
	G312 GC fixed CAN	✓	✓	✓	✓	✓	✓	✓	✓
	G313 GC	✓	✓	✓	✓	✓	✓	✓	✓
	G313 GC fixed CAN	✓	✓	✓	✓	✓	✓	✓	✓
	G314	✓	✓	✓	✓	✓	✓	✓	✓
Mobile Scrap and Demolition Shears	S3015 Flat Top	✓	✓	✓	✓	✓	✓	✓	✓
Pulverizers	P214 Secondary Pulverizer			✓				✓	
Compactors (Vibratory Plate)	CVP75	✓	✓	✓	✓	✓	✓	✓	✓

CW-20 DEDICATED COUPLER ATTACHMENTS (continued)

Undercarriage		Front and Rear Outriggers				Rear Blade			
Counterweight		3300 kg (7,280 lb)				3300 kg (7,280 lb)			
Boom Type		Variable Adjustable		4.65 m (15'3") One-Piece		Variable Adjustable		4.65 m (15'3") One-Piece	
Stick Length		2.20 m (7'3")	2.50 m (8'2")	2.20 m (7'3")	2.50 m (8'2")	2.20 m (7'3")	2.50 m (8'2")	2.20 m (7'3")	2.50 m (8'2")
Hydraulic Hammers	H110 GC S	✓	✓	✓	✓	✓	✓	✓	✓
	H110 S	✓	✓	✓	✓	✓	✓	✓	✓
	H115 GC S	✓	✓	✓	✓	✓*		✓	✓
	H115 S	✓	✓	✓	✓	✓	✓	✓	✓
Demolition and Sorting Grapples	G312 GC	✓	✓	✓	✓	✓*	✓*	✓	✓
	G312 GC fixed CAN	✓	✓	✓	✓	✓	✓*	✓	✓
	G313 GC	✓	✓	✓	✓			✓	✓
	G313 GC fixed CAN	✓	✓	✓	✓	✓*		✓	✓
	G314	✓	✓	✓	✓			✓	✓*
Mobile Scrap and Demolition Shears	S3015 Flat Top	✓	✓	✓	✓			✓*	✓*
Pulverizers	P214 Secondary Pulverizer			✓					
Compactors (Vibratory Plate)	CVP75	✓	✓	✓	✓	✓	✓	✓	✓

(continued on next page)

M314 Wheeled Excavator Specifications

Attachments Offering Guide – Europe (continued)

Not all Attachments are available in all regions. Consult your Cat dealer for configurations available in your region.

Match * Working range front only No Match

HCCW20 DEDICATED COUPLER ATTACHMENTS

Undercarriage		Front Blade; Rear Outriggers	Front Outriggers; Rear Blade	Front and Rear Outriggers	Front Blade; Rear Outriggers			
Counterweight		3300 kg (7,280 lb)	3300 kg (7,280 lb)	3300 kg (7,280 lb)	3300 kg (7,280 lb)			
Boom Type		4.65 m (15'3") One-Piece	4.65 m (15'3") One-Piece	4.65 m (15'3") One-Piece	Variable Adjustable	4.65 m (15'3") One-Piece		
Stick Length		2.20 m (7'3")	2.20 m (7'3")	2.20 m (7'3")	2.20 m (7'3")	2.50 m (8'2")	2.20 m (7'3")	2.50 m (8'2")
Hydraulic Hammers	H110 GC S				✓	✓	✓	✓
	H110 S				✓	✓	✓	✓
	H115 GC S						✓	✓
	H115 S				✓	✓	✓	✓
Demolition and Sorting Grapples	G312 GC				✓	✓	✓	✓
	G313 GC						✓	
	G314						✓	
Mobile Scrap and Demolition Shears	S3015 Flat Top	✓	✓	✓			✓	
Compactors (Vibratory Plate)	CVP75				✓	✓	✓	✓

HCCW20 DEDICATED COUPLER ATTACHMENTS (continued)

Undercarriage		Front Outriggers; Rear Blade				Front and Rear Outriggers			
Counterweight		3300 kg (7,280 lb)				3300 kg (7,280 lb)			
Boom Type		Variable Adjustable		4.65 m (15'3") One-Piece		Variable Adjustable		4.65 m (15'3") One-Piece	
Stick Length		2.20 m (7'3")	2.50 m (8'2")	2.20 m (7'3")	2.50 m (8'2")	2.20 m (7'3")	2.50 m (8'2")	2.20 m (7'3")	2.50 m (8'2")
Hydraulic Hammers	H110 GC S	✓	✓	✓	✓	✓	✓	✓	✓
	H110 S	✓	✓	✓	✓	✓	✓	✓	✓
	H115 GC S			✓	✓			✓	✓
	H115 S	✓	✓	✓	✓	✓	✓	✓	✓
Demolition and Sorting Grapples	G312 GC	✓	✓	✓	✓	✓	✓	✓	✓
	G313 GC			✓				✓	
	G314			✓				✓	
Mobile Scrap and Demolition Shears	S3015 Flat Top			✓			✓		
Compactors (Vibratory Plate)	CVP75	✓	✓	✓	✓	✓	✓	✓	✓

HCCW20 DEDICATED COUPLER ATTACHMENTS (continued)

Undercarriage		Rear Blade			
Counterweight		3300 kg (7,280 lb)			
Boom Type		Variable Adjustable		4.65 m (15'3") One-Piece	
Stick Length		2.20 m (7'3")	2.50 m (8'2")	2.20 m (7'3")	2.50 m (8'2")
Hydraulic Hammers	H110 GC S			✓	✓
	H110 S		✓	✓*	✓
	H115 S			✓	✓
Demolition and Sorting Grapples	G312 GC			✓*	
Compactors (Vibratory Plate)	CVP75	✓	✓	✓	✓

(continued on next page)

M314 Wheeled Excavator Specifications

Attachments Offering Guide – Europe (continued)

Not all Attachments are available in all regions. Consult your Cat dealer for configurations available in your region.

Match

* Working range front only

No Match

S60 DEDICATED COUPLER ATTACHMENTS

Undercarriage		Front Blade; Rear Outriggers				Front Outriggers; Rear Blade			
Counterweight		3300 kg (7,280 lb)				3300 kg (7,280 lb)			
Boom Type		Variable Adjustable		4.65 m (15'3") One-Piece		Variable Adjustable		4.65 m (15'3") One-Piece	
Stick Length		2.20 m (7'3")	2.50 m (8'2")	2.20 m (7'3")	2.50 m (8'2")	2.20 m (7'3")	2.50 m (8'2")	2.20 m (7'3")	2.50 m (8'2")
Hydraulic Hammers	H110 GC S	✓	✓	✓	✓	✓	✓	✓	✓
	H110 S	✓	✓	✓	✓	✓	✓	✓	✓
	H115 GC S	✓	✓	✓	✓	✓	✓	✓	✓
	H115 S	✓	✓	✓	✓	✓	✓	✓	✓
Demolition and Sorting Grapples	G312 GC	✓	✓	✓	✓	✓	✓	✓	✓
	G313 GC	✓	✓	✓	✓	✓	✓	✓	✓
	G314	✓	✓	✓	✓	✓	✓	✓	✓
Mobile Scrap and Demolition Shears	S3015 Flat Top	✓	✓	✓	✓	✓	✓	✓	✓
Pulverizers	P214 Secondary Pulverizer			✓				✓	
Compactors (Vibratory Plate)	CVP75	✓	✓	✓	✓	✓	✓	✓	✓

S60 DEDICATED COUPLER ATTACHMENTS (continued)

Undercarriage		Front and Rear Outriggers				Rear Blade			
Counterweight		3300 kg (7,280 lb)				3300 kg (7,280 lb)			
Boom Type		Variable Adjustable		4.65 m (15'3") One-Piece		Variable Adjustable		4.65 m (15'3") One-Piece	
Stick Length		2.20 m (7'3")	2.50 m (8'2")	2.20 m (7'3")	2.50 m (8'2")	2.20 m (7'3")	2.50 m (8'2")	2.20 m (7'3")	2.50 m (8'2")
Hydraulic Hammers	H110 GC S	✓	✓	✓	✓	✓	✓	✓	✓
	H110 S	✓	✓	✓	✓	✓	✓	✓	✓
	H115 GC S	✓	✓	✓	✓	✓	✓	✓	✓
	H115 S	✓	✓	✓	✓	✓	✓	✓	✓
Demolition and Sorting Grapples	G312 GC	✓	✓	✓	✓	✓	✓*	✓	✓
	G313 GC	✓	✓	✓	✓	✓*		✓	✓
	G314	✓	✓	✓	✓			✓	✓*
Mobile Scrap and Demolition Shears	S3015 Flat Top	✓	✓	✓	✓			✓	✓*
Pulverizers	P214 Secondary Pulverizer			✓					
Compactors (Vibratory Plate)	CVP75	✓	✓	✓	✓	✓	✓	✓	✓

(continued on next page)

M314 Wheeled Excavator Specifications

Attachments Offering Guide – Europe (continued)

Not all Attachments are available in all regions. Consult your Cat dealer for configurations available in your region.

Match

* Working range front only

No Match

HCS60 COUPLER ATTACHMENTS

Undercarriage		Front Blade; Rear Outriggers				Front Outriggers; Rear Blade			
Counterweight		3300 kg (7,280 lb)				3300 kg (7,280 lb)			
Boom Type		Variable Adjustable		4.65 m (15'3") One-Piece		Variable Adjustable		4.65 m (15'3") One-Piece	
Stick Length		2.20 m (7'3")	2.50 m (8'2")	2.20 m (7'3")	2.50 m (8'2")	2.20 m (7'3")	2.50 m (8'2")	2.20 m (7'3")	2.50 m (8'2")
Hydraulic Hammers	H110 S	✓	✓	✓	✓	✓	✓	✓	✓
	H115 S	✓	✓	✓	✓	✓	✓	✓	✓
Demolition and Sorting Grapples	G312 GC	✓	✓	✓	✓	✓	✓	✓	✓
	G313 GC	✓	✓	✓	✓	✓	✓	✓	✓
	G314	✓	✓	✓	✓	✓	✓	✓	✓
Mobile Scrap and Demolition Shears	S3015 Flat Top	✓		✓	✓	✓		✓	✓
Pulverizers	P214 Secondary Pulverizer			✓				✓	
Compactors (Vibratory Plate)	CVP75	✓	✓	✓	✓	✓	✓	✓	✓

HCS60 COUPLER ATTACHMENTS (continued)

Undercarriage		Front and Rear Outriggers				Rear Blade			
Counterweight		3300 kg (7,280 lb)				3300 kg (7,280 lb)			
Boom Type		Variable Adjustable		4.65 m (15'3") One-Piece		Variable Adjustable		4.65 m (15'3") One-Piece	
Stick Length		2.20 m (7'3")	2.50 m (8'2")	2.20 m (7'3")	2.50 m (8'2")	2.20 m (7'3")	2.50 m (8'2")	2.20 m (7'3")	2.50 m (8'2")
Hydraulic Hammers	H110 S	✓	✓	✓	✓	✓	✓	✓	✓
	H115 S	✓	✓	✓	✓	✓	✓	✓	✓
Demolition and Sorting Grapples	G312 GC	✓	✓	✓	✓	✓*		✓	✓
	G313 GC	✓	✓	✓	✓			✓	✓*
	G314	✓	✓	✓	✓			✓*	
Mobile Scrap and Demolition Shears	S3015 Flat Top	✓		✓	✓			✓*	
Pulverizers	P214 Secondary Pulverizer			✓					
Compactors (Vibratory Plate)	CVP75	✓	✓	✓	✓	✓	✓	✓	✓

(continued on next page)

M314 Wheeled Excavator Specifications

Attachments Offering Guide – Europe (continued)

Not all Attachments are available in all regions. Consult your Cat dealer for configurations available in your region.

Match

* Working range front only

No Match

HCS65 COUPLER ATTACHMENTS

Undercarriage		Front Blade; Rear Outriggers				Front Outriggers; Rear Blade			
Counterweight		3300 kg (7,280 lb)				3300 kg (7,280 lb)			
Boom Type		Variable Adjustable		4.65 m (15'3") One-Piece		Variable Adjustable		4.65 m (15'3") One-Piece	
Stick Length		2.20 m (7'3")	2.50 m (8'2")	2.20 m (7'3")	2.50 m (8'2")	2.20 m (7'3")	2.50 m (8'2")	2.20 m (7'3")	2.50 m (8'2")
Hydraulic Hammers	H110 S	✓	✓	✓	✓	✓	✓	✓	✓
	H115 S	✓	✓	✓	✓	✓	✓	✓	✓
Demolition and Sorting Grapples	G312 GC	✓	✓	✓	✓	✓	✓	✓	✓
	G313 GC	✓	✓	✓	✓	✓	✓	✓	✓
	G314	✓		✓	✓	✓		✓	✓
Mobile Scrap and Demolition Shears	S3015 Flat Top			✓				✓	
Pulverizers	P214 Secondary Pulverizer			✓				✓	
Compactors (Vibratory Plate)	CVP75	✓	✓	✓	✓	✓	✓	✓	✓

HCS65 COUPLER ATTACHMENTS (continued)

Undercarriage		Front and Rear Outriggers				Rear Blade			
Counterweight		3300 kg (7,280 lb)				3300 kg (7,280 lb)			
Boom Type		Variable Adjustable		4.65 m (15'3") One-Piece		Variable Adjustable		4.65 m (15'3") One-Piece	
Stick Length		2.20 m (7'3")	2.50 m (8'2")	2.20 m (7'3")	2.50 m (8'2")	2.20 m (7'3")	2.50 m (8'2")	2.20 m (7'3")	2.50 m (8'2")
Hydraulic Hammers	H110 S	✓	✓	✓	✓	✓	✓	✓	✓
	H115 S	✓	✓	✓	✓	✓	✓	✓	✓
Demolition and Sorting Grapples	G312 GC	✓	✓	✓	✓			✓	✓*
	G313 GC	✓	✓	✓	✓			✓*	
	G314	✓		✓	✓				
Mobile Scrap and Demolition Shears	S3015 Flat Top			✓					
Pulverizers	P214 Secondary Pulverizer			✓					
Compactors (Vibratory Plate)	CVP75	✓	✓	✓	✓	✓	✓	✓	✓

(continued on next page)

M314 Wheeled Excavator Specifications

Attachments Offering Guide – Europe (continued)

Not all Attachments are available in all regions. Consult your Cat dealer for configurations available in your region.

Match

* Working range front only

No Match

TRS10 (PIN-ON TOP/CW-20s BOTTOM ATTACHMENTS)

Some attachments require more hydraulic flow and are best suited with a machine that has HP2 circuits and a tiltrotator with a high flow swivel. Check the hydraulic capability of your machine and tiltrotator and the requirements of your attachment to ensure a proper match.

Undercarriage		Front Blade; Rear Outriggers				Front Outriggers; Rear Blade			
Counterweight		3300 kg (7,280 lb)				3300 kg (7,280 lb)			
Boom Type		Variable Adjustable		4.65 m (15'3") One-Piece		Variable Adjustable		4.65 m (15'3") One-Piece	
Stick Length		2.20 m (7'3")	2.50 m (8'2")	2.20 m (7'3")	2.50 m (8'2")	2.20 m (7'3")	2.50 m (8'2")	2.20 m (7'3")	2.50 m (8'2")
Hydraulic Hammers	H110 GC S			✓	✓			✓	✓
	H110 S			✓	✓			✓	✓
Demolition and Sorting Grapples	G212 GC	✓	✓	✓	✓	✓	✓	✓	✓
	G212 GC fixed CAN	✓	✓	✓	✓	✓	✓	✓	✓
	G213 GC			✓	✓			✓	✓
	G213 GC fixed CAN	✓	✓	✓	✓	✓	✓	✓	✓
Compactors (Vibratory Plate)	CVP75	✓	✓	✓	✓	✓	✓	✓	✓

NOTE: Use hammers on tiltrotators less than 10% of working hours per year or maximum 200 hours per year. Refer to your Operation and Maintenance Manual for recommended hydraulic flow requirements.

TRS10 (PIN-ON TOP/CW-20s BOTTOM ATTACHMENTS (continued))

Some attachments require more hydraulic flow and are best suited with a machine that has HP2 circuits and a tiltrotator with a high flow swivel. Check the hydraulic capability of your machine and tiltrotator and the requirements of your attachment to ensure a proper match.

Undercarriage		Front and Rear Outriggers				Rear Blade		
Counterweight		3300 kg (7,280 lb)				3300 kg (7,280 lb)		
Boom Type		Variable Adjustable		4.65 m (15'3") One-Piece		Variable Adjustable	4.65 m (15'3") One-Piece	
Stick Length		2.20 m (7'3")	2.50 m (8'2")	2.20 m (7'3")	2.50 m (8'2")	2.20 m (7'3")	2.20 m (7'3")	2.50 m (8'2")
Hydraulic Hammers	H110 GC S			✓	✓		✓*	
	H110 S			✓	✓		✓	✓*
Demolition and Sorting Grapples	G212 GC	✓	✓	✓	✓		✓	✓*
	G212 GC fixed CAN	✓	✓	✓	✓		✓	✓
	G213 GC			✓	✓			
	G213 GC fixed CAN	✓	✓	✓	✓		✓*	✓*
Compactors (Vibratory Plate)	CVP75	✓	✓	✓	✓	✓*	✓	✓

NOTE: Use hammers on tiltrotators less than 10% of working hours per year or maximum 200 hours per year. Refer to your Operation and Maintenance Manual for recommended hydraulic flow requirements.

(continued on next page)

M314 Wheeled Excavator Specifications

Attachments Offering Guide – Europe (continued)

Not all Attachments are available in all regions. Consult your Cat dealer for configurations available in your region.

Match

* Working range front only

No Match

TRS10 (CW-20s TOP/CW-20s BOTTOM) ATTACHMENTS

Some attachments require more hydraulic flow and are best suited with a machine that has HP2 circuits and a tiltrotator with a high flow swivel. Check the hydraulic capability of your machine and tiltrotator and the requirements of your attachment to ensure a proper match.

Undercarriage		Front Blade; Rear Outriggers	Front Outriggers; Rear Blade	Front and Rear Outriggers	Rear Blade
Counterweight		3300 kg (7,280 lb)	3300 kg (7,280 lb)	3300 kg (7,280 lb)	3300 kg (7,280 lb)
Boom Type		4.65 m (15'3") One-Piece	4.65 m (15'3") One-Piece	4.65 m (15'3") One-Piece	4.65 m (15'3") One-Piece
Stick Length		2.20 m (7'3") 2.50 m (8'2")	2.20 m (7'3") 2.50 m (8'2")	2.20 m (7'3") 2.50 m (8'2")	2.20 m (7'3")
Hydraulic Hammers	H110 S	✓	✓	✓	
Demolition and Sorting Grapples	G212 GC	✓	✓	✓	
	G212 GC fixed CAN	✓	✓	✓	✓
	G213 GC	✓	✓	✓	
	G213 GC fixed CAN	✓	✓	✓	
Compactors (Vibratory Plate)	CVP75	✓	✓	✓	✓*

NOTE: Use hammers on tiltrotators less than 10% of working hours per year or maximum 200 hours per year. Refer to your Operation and Maintenance Manual for recommended hydraulic flow requirements.

TRS10 (PIN-ON TOP/CW-20 BOTTOM) ATTACHMENTS

Some attachments require more hydraulic flow and are best suited with a machine that has HP2 circuits and a tiltrotator with a high flow swivel. Check the hydraulic capability of your machine and tiltrotator and the requirements of your attachment to ensure a proper match.

Undercarriage		Front Blade; Rear Outriggers				Front Outriggers; Rear Blade			
Counterweight		3300 kg (7,280 lb)				3300 kg (7,280 lb)			
Boom Type		Variable Adjustable		4.65 m (15'3") One-Piece		Variable Adjustable		4.65 m (15'3") One-Piece	
Stick Length		2.20 m (7'3")	2.50 m (8'2")	2.20 m (7'3")	2.50 m (8'2")	2.20 m (7'3")	2.50 m (8'2")	2.20 m (7'3")	2.50 m (8'2")
Hydraulic Hammers	H110 GC S			✓	✓			✓	✓
	H110 S	✓		✓	✓	✓		✓	✓
Demolition and Sorting Grapples	G212 GC	✓	✓	✓	✓	✓	✓	✓	✓
	G212 GC fixed CAN	✓	✓	✓	✓	✓	✓	✓	✓
	G213 GC	✓		✓	✓	✓		✓	✓
	G213 GC fixed CAN	✓	✓	✓	✓	✓	✓	✓	✓
Compactors (Vibratory Plate)	CVP75	✓	✓	✓	✓	✓	✓	✓	✓

NOTE: Use hammers on tiltrotators less than 10% of working hours per year or maximum 200 hours per year. Refer to your Operation and Maintenance Manual for recommended hydraulic flow requirements.

(continued on next page)

M314 Wheeled Excavator Specifications

Attachments Offering Guide – Europe (continued)

Not all Attachments are available in all regions. Consult your Cat dealer for configurations available in your region.

Match

* Working range front only

No Match

TRS10 (PIN-ON TOP/CW-20 BOTTOM) ATTACHMENTS (continued)

Some attachments require more hydraulic flow and are best suited with a machine that has HP2 circuits and a tiltrotator with a high flow swivel. Check the hydraulic capability of your machine and tiltrotator and the requirements of your attachment to ensure a proper match.

Undercarriage		Front and Rear Outriggers				Rear Blade		
Counterweight		3300 kg (7,280 lb)				3300 kg (7,280 lb)		
Boom Type		Variable Adjustable		4.65 m (15'3") One-Piece		Variable Adjustable	4.65 m (15'3") One-Piece	
Stick Length		2.20 m (7'3")	2.50 m (8'2")	2.20 m (7'3")	2.50 m (8'2")	2.20 m (7'3")	2.20 m (7'3")	2.50 m (8'2")
Hydraulic Hammers	H110 GC S			✓	✓		✓*	✓*
	H110 S	✓		✓	✓		✓	✓*
Demolition and Sorting Grapples	G212 GC	✓	✓	✓	✓		✓	✓*
	G212 GC fixed CAN	✓	✓	✓	✓	✓*	✓	✓
	G213 GC	✓		✓	✓			
	G213 GC fixed CAN	✓	✓	✓	✓		✓	✓*
Compactors (Vibratory Plate)	CVP75	✓	✓	✓	✓	✓*	✓	✓

NOTE: Use hammers on tiltrotators less than 10% of working hours per year or maximum 200 hours per year. Refer to your Operation and Maintenance Manual for recommended hydraulic flow requirements.

TRS10 (PIN-ON TOP/S60 BOTTOM) ATTACHMENTS

Some attachments require more hydraulic flow and are best suited with a machine that has HP2 circuits and a tiltrotator with a high flow swivel. Check the hydraulic capability of your machine and tiltrotator and the requirements of your attachment to ensure a proper match.

Undercarriage		Front Blade; Rear Outriggers				Front Outriggers; Rear Blade			
Counterweight		3300 kg (7,280 lb)				3300 kg (7,280 lb)			
Boom Type		Variable Adjustable		4.65 m (15'3") One-Piece		Variable Adjustable		4.65 m (15'3") One-Piece	
Stick Length		2.20 m (7'3")	2.50 m (8'2")	2.20 m (7'3")	2.50 m (8'2")	2.20 m (7'3")	2.50 m (8'2")	2.20 m (7'3")	2.50 m (8'2")
Hydraulic Hammers	H110 GC S	✓	✓	✓	✓	✓	✓	✓	✓
	H110 S	✓	✓			✓	✓		
Demolition and Sorting Grapples	G212 GC	✓	✓	✓	✓	✓	✓	✓	✓
	G213 GC	✓	✓	✓	✓	✓	✓	✓	✓
Compactors (Vibratory Plate)	CVP75	✓	✓	✓	✓	✓	✓	✓	✓

NOTE: Use hammers on tiltrotators less than 10% of working hours per year or maximum 200 hours per year. Refer to your Operation and Maintenance Manual for recommended hydraulic flow requirements.

(continued on next page)

M314 Wheeled Excavator Specifications

Attachments Offering Guide – Europe (continued)

Not all Attachments are available in all regions. Consult your Cat dealer for configurations available in your region.

Match

* Working range front only

No Match

TRS10 (PIN-ON TOP/S60 BOTTOM) ATTACHMENTS (continued)

Some attachments require more hydraulic flow and are best suited with a machine that has HP2 circuits and a tiltrotator with a high flow swivel. Check the hydraulic capability of your machine and tiltrotator and the requirements of your attachment to ensure a proper match.

Undercarriage		Front and Rear Outriggers				Rear Blade			
Counterweight		3300 kg (7,280 lb)				3300 kg (7,280 lb)			
Boom Type		Variable Adjustable		4.65 m (15'3") One-Piece		Variable Adjustable		4.65 m (15'3") One-Piece	
Stick Length		2.20 m (7'3")	2.50 m (8'2")	2.20 m (7'3")	2.50 m (8'2")	2.20 m (7'3")	2.50 m (8'2")	2.20 m (7'3")	2.50 m (8'2")
Hydraulic Hammers	H110 GC S	✓	✓	✓	✓	✓*	✓*	✓	✓
	H110 S	✓	✓			✓	✓*		
Demolition and Sorting Grapples	G212 GC	✓	✓	✓	✓	✓*		✓	✓
	G213 GC	✓	✓	✓	✓			✓	✓*
Compactors (Vibratory Plate)	CVP75	✓	✓	✓	✓	✓	✓	✓	✓

NOTE: Use hammers on tiltrotators less than 10% of working hours per year or maximum 200 hours per year. Refer to your Operation and Maintenance Manual for recommended hydraulic flow requirements.

TRS10 (S60 TOP/S60 BOTTOM) ATTACHMENTS

Some attachments require more hydraulic flow and are best suited with a machine that has HP2 circuits and a tiltrotator with a high flow swivel. Check the hydraulic capability of your machine and tiltrotator and the requirements of your attachment to ensure a proper match.

Undercarriage		Front Blade; Rear Outriggers				Front Outriggers; Rear Blade			
Counterweight		3300 kg (7,280 lb)				3300 kg (7,280 lb)			
Boom Type		Variable Adjustable		4.65 m (15'3") One-Piece		Variable Adjustable		4.65 m (15'3") One-Piece	
Stick Length		2.20 m (7'3")	2.50 m (8'2")	2.20 m (7'3")	2.50 m (8'2")	2.20 m (7'3")	2.50 m (8'2")	2.20 m (7'3")	2.50 m (8'2")
Hydraulic Hammers	H110 GC S	✓	✓	✓	✓	✓	✓	✓	✓
	H110 S	✓	✓	✓	✓	✓	✓	✓	✓
Demolition and Sorting Grapples	G212 GC	✓	✓	✓	✓	✓	✓	✓	✓
	G213 GC	✓		✓	✓	✓		✓	✓
Compactors (Vibratory Plate)	CVP75	✓	✓	✓	✓	✓	✓	✓	✓

NOTE: Use hammers on tiltrotators less than 10% of working hours per year or maximum 200 hours per year. Refer to your Operation and Maintenance Manual for recommended hydraulic flow requirements.

(continued on next page)

M314 Wheeled Excavator Specifications

Attachments Offering Guide – Europe (continued)

Not all Attachments are available in all regions. Consult your Cat dealer for configurations available in your region.

Match

* Working range front only

No Match

TRS10 (S60 TOP/S60 BOTTOM) ATTACHMENTS (continued)

Some attachments require more hydraulic flow and are best suited with a machine that has HP2 circuits and a tiltrotator with a high flow swivel. Check the hydraulic capability of your machine and tiltrotator and the requirements of your attachment to ensure a proper match.

Undercarriage		Front and Rear Outriggers				Rear Blade			
Counterweight		3300 kg (7,280 lb)				3300 kg (7,280 lb)			
Boom Type		Variable Adjustable		4.65 m (15'3") One-Piece		Variable Adjustable		4.65 m (15'3") One-Piece	
Stick Length		2.20 m (7'3")	2.50 m (8'2")	2.20 m (7'3")	2.50 m (8'2")	2.20 m (7'3")	2.50 m (8'2")	2.20 m (7'3")	2.50 m (8'2")
Hydraulic Hammers	H110 GC S	✓	✓	✓	✓			✓	✓*
	H110 S	✓	✓	✓	✓			✓	✓
Demolition and Sorting Grapples	G212 GC	✓	✓	✓	✓			✓	✓*
	G213 GC	✓		✓	✓				
Compactors (Vibratory Plate)	CVP75	✓	✓	✓	✓	✓	✓*	✓	✓

NOTE: Use hammers on tiltrotators less than 10% of working hours per year or maximum 200 hours per year. Refer to your Operation and Maintenance Manual for recommended hydraulic flow requirements.

TRS10 (PIN-ON TOP/HCS60 BOTTOM) ATTACHMENTS

Some attachments require more hydraulic flow and are best suited with a machine that has HP2 circuits and a tiltrotator with a high flow swivel. Check the hydraulic capability of your machine and tiltrotator and the requirements of your attachment to ensure a proper match.

Undercarriage		Front Blade; Rear Outriggers				Front Outriggers; Rear Blade			
Counterweight		3300 kg (7,280 lb)				3300 kg (7,280 lb)			
Boom Type		Variable Adjustable		4.65 m (15'3") One-Piece		Variable Adjustable		4.65 m (15'3") One-Piece	
Stick Length		2.20 m (7'3")	2.50 m (8'2")	2.20 m (7'3")	2.50 m (8'2")	2.20 m (7'3")	2.50 m (8'2")	2.20 m (7'3")	2.50 m (8'2")
Hydraulic Hammers	H110 S	✓	✓	✓	✓	✓	✓	✓	✓
Compactors (Vibratory Plate)	CVP75	✓	✓	✓	✓	✓	✓	✓	✓

NOTE: Use hammers on tiltrotators less than 10% of working hours per year or maximum 200 hours per year. Refer to your Operation and Maintenance Manual for recommended hydraulic flow requirements.

TRS10 (PIN-ON TOP/HCS60 BOTTOM) ATTACHMENTS (continued)

Some attachments require more hydraulic flow and are best suited with a machine that has HP2 circuits and a tiltrotator with a high flow swivel. Check the hydraulic capability of your machine and tiltrotator and the requirements of your attachment to ensure a proper match.

Undercarriage		Front and Rear Outriggers				Rear Blade			
Counterweight		3300 kg (7,280 lb)				3300 kg (7,280 lb)			
Boom Type		Variable Adjustable		4.65 m (15'3") One-Piece		Variable Adjustable		4.65 m (15'3") One-Piece	
Stick Length		2.20 m (7'3")	2.50 m (8'2")	2.20 m (7'3")	2.50 m (8'2")	2.20 m (7'3")	2.50 m (8'2")	2.20 m (7'3")	2.50 m (8'2")
Hydraulic Hammers	H110 S	✓	✓	✓	✓	✓*		✓	✓
Compactors (Vibratory Plate)	CVP75	✓	✓	✓	✓	✓	✓	✓	✓

NOTE: Use hammers on tiltrotators less than 10% of working hours per year or maximum 200 hours per year. Refer to your Operation and Maintenance Manual for recommended hydraulic flow requirements.

(continued on next page)

M314 Wheeled Excavator Specifications

Attachments Offering Guide – Europe (continued)

Not all Attachments are available in all regions. Consult your Cat dealer for configurations available in your region.

Match

* Working range front only

No Match

TRS10 (HCS60 TOP/HCS60 BOTTOM) ATTACHMENTS

Some attachments require more hydraulic flow and are best suited with a machine that has HP2 circuits and a tiltrotator with a high flow swivel. Check the hydraulic capability of your machine and tiltrotator and the requirements of your attachment to ensure a proper match.

Undercarriage		Front Blade; Rear Outriggers				Front Outriggers; Rear Blade			
Counterweight		3300 kg (7,280 lb)				3300 kg (7,280 lb)			
Boom Type		Variable Adjustable	4.65 m (15'3") One-Piece		Variable Adjustable	4.65 m (15'3") One-Piece			
Stick Length		2.20 m (7'3")	2.50 m (8'2")	2.20 m (7'3")	2.50 m (8'2")	2.20 m (7'3")	2.50 m (8'2")	2.20 m (7'3")	2.50 m (8'2")
Hydraulic Hammers	H110 S	✓	✓	✓	✓	✓	✓	✓	✓
Compactors (Vibratory Plate)	CVP75	✓	✓	✓	✓	✓	✓	✓	✓

NOTE: Use hammers on tiltrotators less than 10% of working hours per year or maximum 200 hours per year. Refer to your Operation and Maintenance Manual for recommended hydraulic flow requirements.

TRS10 (HCS60 TOP/HCS60 BOTTOM) ATTACHMENTS (continued)

Some attachments require more hydraulic flow and are best suited with a machine that has HP2 circuits and a tiltrotator with a high flow swivel. Check the hydraulic capability of your machine and tiltrotator and the requirements of your attachment to ensure a proper match.

Undercarriage		Front and Rear Outriggers				Rear Blade		
Counterweight		3300 kg (7,280 lb)				3300 kg (7,280 lb)		
Boom Type		Variable Adjustable	4.65 m (15'3") One-Piece		Variable Adjustable	4.65 m (15'3") One-Piece		
Stick Length		2.20 m (7'3")	2.50 m (8'2")	2.20 m (7'3")	2.50 m (8'2")	2.20 m (7'3")	2.20 m (7'3")	2.50 m (8'2")
Hydraulic Hammers	H110 S	✓	✓	✓	✓		✓*	✓*
Compactors (Vibratory Plate)	CVP75	✓	✓	✓	✓	✓*	✓	✓

NOTE: Use hammers on tiltrotators less than 10% of working hours per year or maximum 200 hours per year. Refer to your Operation and Maintenance Manual for recommended hydraulic flow requirements.

M314 Wheeled Excavator Specifications

Attachments Offering Guide – Australia New Zealand

Not all Attachments are available in all regions. Consult your Cat dealer for configurations available in your region.

Match

* Working range front only

No Match

PIN-ON ATTACHMENTS

Undercarriage		Front Blade; Rear Outriggers				Front Outriggers; Rear Blade			
Counterweight		3300 kg (7,280 lb)				3300 kg (7,280 lb)			
Boom Type		Variable Adjustable		4.65 m (15'3") One-Piece		Variable Adjustable		4.65 m (15'3") One-Piece	
Stick Length		2.20 m (7'3")	2.50 m (8'2")	2.20 m (7'3")	2.50 m (8'2")	2.20 m (7'3")	2.50 m (8'2")	2.20 m (7'3")	2.50 m (8'2")
Hydraulic Hammers	H110 GC	✓	✓	✓	✓	✓	✓	✓	✓
	H110 GC S	✓	✓	✓	✓	✓	✓	✓	✓
	H110 S	✓	✓			✓	✓		
	H115 GC	✓	✓	✓	✓	✓	✓	✓	✓
	H115 GC S	✓	✓	✓	✓	✓	✓	✓	✓
	H115 S	✓	✓			✓	✓		
Demolition and Sorting Grapples	G314	✓	✓	✓	✓	✓	✓	✓	✓
Mobile Scrap and Demolition Shears	S3015 Flat Top			✓	✓			✓	✓
Mulchers	HM2615	✓	✓	✓	✓	✓	✓	✓	✓
	HM3013	✓	✓	✓	✓	✓	✓	✓	✓
Compactors (Vibratory Plate)	CVP75	✓	✓	✓	✓	✓	✓	✓	✓

PIN-ON ATTACHMENTS (continued)

Undercarriage		Front and Rear Outriggers				Rear Blade			
Counterweight		3300 kg (7,280 lb)				3300 kg (7,280 lb)			
Boom Type		Variable Adjustable		4.65 m (15'3") One-Piece		Variable Adjustable		4.65 m (15'3") One-Piece	
Stick Length		2.20 m (7'3")	2.50 m (8'2")	2.20 m (7'3")	2.50 m (8'2")	2.20 m (7'3")	2.50 m (8'2")	2.20 m (7'3")	2.50 m (8'2")
Hydraulic Hammers	H110 GC	✓	✓	✓	✓	✓	✓	✓	✓
	H110 GC S	✓	✓	✓	✓	✓	✓	✓	✓
	H110 S	✓	✓			✓	✓		
	H115 GC	✓	✓	✓	✓	✓	✓	✓	✓
	H115 GC S	✓	✓	✓	✓	✓	✓	✓	✓
	H115 S	✓	✓			✓	✓		
Demolition and Sorting Grapples	G314	✓	✓	✓	✓	✓*	✓*	✓	✓
Mobile Scrap and Demolition Shears	S3015 Flat Top			✓	✓			✓	✓
Mulchers	HM2615	✓	✓	✓	✓	✓	✓	✓	✓
	HM3013	✓	✓	✓	✓	✓	✓	✓	✓
Compactors (Vibratory Plate)	CVP75	✓	✓	✓	✓	✓	✓	✓	✓

(continued on next page)

M314 Wheeled Excavator Specifications

Attachments Offering Guide – Australia New Zealand (continued)

Not all Attachments are available in all regions. Consult your Cat dealer for configurations available in your region.

Match * Working range front only No Match

CAT PIN GRABBER COUPLER ATTACHMENTS

Undercarriage		Front Blade; Rear Outriggers				Front Outriggers; Rear Blade			
Counterweight		3300 kg (7,280 lb)				3300 kg (7,280 lb)			
Boom Type		Variable Adjustable		4.65 m (15'3") One-Piece		Variable Adjustable		4.65 m (15'3") One-Piece	
Stick Length		2.20 m (7'3")	2.50 m (8'2")	2.20 m (7'3")	2.50 m (8'2")	2.20 m (7'3")	2.50 m (8'2")	2.20 m (7'3")	2.50 m (8'2")
Hydraulic Hammers	H110 GC	✓	✓	✓	✓	✓	✓	✓	✓
	H110 GC S	✓	✓	✓	✓	✓	✓	✓	✓
	H110 S	✓	✓			✓	✓		
	H115 GC	✓	✓	✓	✓	✓	✓	✓	✓
	H115 GC S	✓	✓	✓	✓	✓	✓	✓	✓
	H115 S	✓	✓			✓	✓		
Demolition and Sorting Grapples	G314			✓	✓			✓	✓
Mobile Scrap and Demolition Shears	S3015 Flat Top			✓	✓			✓	✓
Mulchers	HM2516	✓	✓	✓	✓	✓	✓	✓	✓
	HM3013	✓	✓	✓	✓	✓	✓	✓	✓
Compactors (Vibratory Plate)	CVP75	✓	✓	✓	✓	✓	✓	✓	✓

CAT PIN GRABBER COUPLER ATTACHMENTS (continued)

Undercarriage		Front and Rear Outriggers				Rear Blade			
Counterweight		3300 kg (7,280 lb)				3300 kg (7,280 lb)			
Boom Type		Variable Adjustable		4.65 m (15'3") One-Piece		Variable Adjustable		4.65 m (15'3") One-Piece	
Stick Length		2.20 m (7'3")	2.50 m (8'2")	2.20 m (7'3")	2.50 m (8'2")	2.20 m (7'3")	2.50 m (8'2")	2.20 m (7'3")	2.50 m (8'2")
Hydraulic Hammers	H110 GC	✓	✓	✓	✓	✓	✓	✓	✓
	H110 GC S	✓	✓	✓	✓	✓	✓	✓	✓
	H110 S	✓	✓			✓	✓		
	H115 GC	✓	✓	✓	✓	✓*		✓	✓
	H115 GC S	✓	✓	✓	✓	✓	✓*	✓	✓
	H115 S	✓	✓			✓	✓		
Demolition and Sorting Grapples	G314			✓	✓			✓*	
Mobile Scrap and Demolition Shears	S3015 Flat Top			✓	✓			✓*	
Mulchers	HM2516	✓	✓	✓	✓	✓	✓	✓	✓
	HM3013	✓	✓	✓	✓	✓*		✓	✓
Compactors (Vibratory Plate)	CVP75	✓	✓	✓	✓	✓	✓	✓	✓

(continued on next page)

M314 Wheeled Excavator Specifications

Attachments Offering Guide – Australia New Zealand (continued)

Not all Attachments are available in all regions. Consult your Cat dealer for configurations available in your region.

Match

* Working range front only

No Match

TRS10 (PIN-ON TOP/S60 BOTTOM) ATTACHMENTS

Some attachments require more hydraulic flow and are best suited with a machine that has HP2 circuits and a tiltrotator with a high flow swivel. Check the hydraulic capability of your machine and tiltrotator and the requirements of your attachment to ensure a proper match.

Undercarriage		Front Blade; Rear Outriggers				Front Outriggers; Rear Blade			
Counterweight		3300 kg (7,280 lb)				3300 kg (7,280 lb)			
Boom Type		Variable Adjustable		4.65 m (15'3") One-Piece		Variable Adjustable		4.65 m (15'3") One-Piece	
Stick Length		2.20 m (7'3")	2.50 m (8'2")	2.20 m (7'3")	2.50 m (8'2")	2.20 m (7'3")	2.50 m (8'2")	2.20 m (7'3")	2.50 m (8'2")
Hydraulic Hammers	H110 GC S	✓	✓	✓	✓	✓	✓	✓	✓
	H110 S	✓	✓			✓	✓		
Compactors (Vibratory Plate)	CVP75	✓	✓	✓	✓	✓	✓	✓	✓

NOTE: Use hammers on tiltrotators less than 10% of working hours per year or maximum 200 hours per year. Refer to your Operation and Maintenance Manual for recommended hydraulic flow requirements.

TRS10 (PIN-ON TOP/S60 BOTTOM) ATTACHMENTS (continued)

Some attachments require more hydraulic flow and are best suited with a machine that has HP2 circuits and a tiltrotator with a high flow swivel. Check the hydraulic capability of your machine and tiltrotator and the requirements of your attachment to ensure a proper match.

Undercarriage		Front and Rear Outriggers				Rear Blade			
Counterweight		3300 kg (7,280 lb)				3300 kg (7,280 lb)			
Boom Type		Variable Adjustable		4.65 m (15'3") One-Piece		Variable Adjustable		4.65 m (15'3") One-Piece	
Stick Length		2.20 m (7'3")	2.50 m (8'2")	2.20 m (7'3")	2.50 m (8'2")	2.20 m (7'3")	2.50 m (8'2")	2.20 m (7'3")	2.50 m (8'2")
Hydraulic Hammers	H110 GC S	✓	✓	✓	✓	✓*	✓*	✓	✓
	H110 S	✓	✓			✓	✓*		
Compactors (Vibratory Plate)	CVP75	✓	✓	✓	✓	✓	✓	✓	✓

NOTE: Use hammers on tiltrotators less than 10% of working hours per year or maximum 200 hours per year. Refer to your Operation and Maintenance Manual for recommended hydraulic flow requirements.

M314 Wheeled Excavator Specifications

Attachments Offering Guide – South Korea

Not all Attachments are available in all regions. Consult your Cat dealer for configurations available in your region.

Match

PIN-ON ATTACHMENTS

Undercarriage		Front Blade; Rear Outriggers				Front Outriggers; Rear Blade			
Counterweight		3300 kg (7,280 lb)				3300 kg (7,280 lb)			
Boom Type		Variable Adjustable	4.65 m (15'3") One-Piece	Variable Adjustable	4.65 m (15'3") One-Piece	Variable Adjustable	4.65 m (15'3") One-Piece	Variable Adjustable	4.65 m (15'3") One-Piece
Stick Length		2.20 m (7'3")	2.50 m (8'2")	2.20 m (7'3")	2.50 m (8'2")	2.20 m (7'3")	2.50 m (8'2")	2.20 m (7'3")	2.50 m (8'2")
Hydraulic Hammers	H110 GC	✓	✓	✓	✓	✓	✓	✓	✓
	H110 GC S	✓	✓	✓	✓	✓	✓	✓	✓
	H115 GC	✓	✓	✓	✓	✓	✓	✓	✓
	H115 GC S	✓	✓	✓	✓	✓	✓	✓	✓

PIN-ON ATTACHMENTS (continued)

Undercarriage		Front and Rear Outriggers				Rear Blade			
Counterweight		3300 kg (7,280 lb)				3300 kg (7,280 lb)			
Boom Type		Variable Adjustable	4.65 m (15'3") One-Piece	Variable Adjustable	4.65 m (15'3") One-Piece	Variable Adjustable	4.65 m (15'3") One-Piece	Variable Adjustable	4.65 m (15'3") One-Piece
Stick Length		2.20 m (7'3")	2.50 m (8'2")	2.20 m (7'3")	2.50 m (8'2")	2.20 m (7'3")	2.50 m (8'2")	2.20 m (7'3")	2.50 m (8'2")
Hydraulic Hammers	H110 GC	✓	✓	✓	✓	✓	✓	✓	✓
	H110 GC S	✓	✓	✓	✓	✓	✓	✓	✓
	H115 GC	✓	✓	✓	✓	✓	✓	✓	✓
	H115 GC S	✓	✓	✓	✓	✓	✓	✓	✓

M314 Wheeled Excavator Specifications

Lift Capacities – Variable Adjustable Boom (5028 mm), 2200 mm Stick

All values are in kg, work tool: none, bucket cylinder and bucket linkage installed, counterweight: 3300 kg, heavy lift function on.

Stick height	Undercarriage configuration	3000 mm			4500 mm			6000 mm			7500 mm			mm
		Load at maximum reach (sticknose/bucket pin)	Load over front	Load over rear	Load over side	Load at maximum reach (sticknose/bucket pin)	Load over front	Load over rear	Load over side	Load at maximum reach (sticknose/bucket pin)	Load over front	Load over rear	Load over side	
7500 mm	Undercarriage: front empty – rear dozer – free on wheels				*3800	*3800	3650				*3700	*3700	3600	4510
	Undercarriage: front empty – rear dozer – stabilized				*3800	*3800	*3800				*3700	*3700	*3700	
	Undercarriage: front dozer – rear stabilizer – stabilized				*3800	*3800	*3800				*3700	*3700	*3700	
	Undercarriage: front stabilizer – rear stabilizer – stabilized				*3800	*3800	*3800				*3700	*3700	*3700	
6000 mm	Undercarriage: front empty – rear dozer – free on wheels				*4750	4100	3750	*3300	2500	2250	*3100	2450	2250	6040
	Undercarriage: front empty – rear dozer – stabilized				*4750	*4750	4150	*3300	*3300	2550	*3100	*3100	*3100	
	Undercarriage: front dozer – rear stabilizer – stabilized				*4750	*4750	*4750	*3300	*3300	*3300	*3100	*3100	*3100	
	Undercarriage: front stabilizer – rear stabilizer – stabilized				*4750	*4750	*4750	*3300	*3300	*3300	*3100	*3100	*3100	
4500 mm	Undercarriage: front empty – rear dozer – free on wheels				*5200	3950	3550	3600	2500	2250	2850	1950	1750	6890
	Undercarriage: front empty – rear dozer – stabilized				*5200	*5200	4000	3600	*4300	2550	2850	*2850	2000	
	Undercarriage: front dozer – rear stabilizer – stabilized				*5200	*5200	*5200	*4300	*4300	3900	*2850	*2850	*2850	
	Undercarriage: front stabilizer – rear stabilizer – stabilized				*5200	*5200	*5200	*4300	*4300	*4300	*2850	*2850	*2850	
3000 mm	Undercarriage: front empty – rear dozer – free on wheels				5400	3600	3250	3500	2350	2150	2550	1700	1550	7340
	Undercarriage: front empty – rear dozer – stabilized				5400	*6000	3700	3500	*4550	2400	2550	*2850	1750	
	Undercarriage: front dozer – rear stabilizer – stabilized				*6000	*6000	5850	*4550	*4550	3750	*2850	*2850	2750	
	Undercarriage: front stabilizer – rear stabilizer – stabilized				*6000	*6000	*6000	*4550	*4550	4550	*2850	*2850	*2850	
1500 mm	Undercarriage: front empty – rear dozer – free on wheels				5100	3350	3000	3350	2250	2000	2450	1650	1450	7450
	Undercarriage: front empty – rear dozer – stabilized				5100	*6550	3400	3350	*4750	2300	2450	*3000	1650	
	Undercarriage: front dozer – rear stabilizer – stabilized				*6550	*6550	5550	*4750	*4750	3650	*3000	*3000	2650	
	Undercarriage: front stabilizer – rear stabilizer – stabilized				*6550	*6550	*6550	*4750	*4750	4400	*3000	*3000	*3000	
0 mm	Undercarriage: front empty – rear dozer – free on wheels				4950	3200	2850	3250	2150	1950	2550	1650	1500	7230
	Undercarriage: front empty – rear dozer – stabilized				4950	*6350	3250	3250	*4650	2200	2500	*3300	1700	
	Undercarriage: front dozer – rear stabilizer – stabilized				*6350	*6350	5400	*4650	*4650	3550	*3300	*3300	2750	
	Undercarriage: front stabilizer – rear stabilizer – stabilized				*6350	*6350	*6350	*4650	*4650	4300	*3300	*3300	*3300	
-1500 mm	Undercarriage: front empty – rear dozer – free on wheels	*6850	5950	5200	4950	3150	2850	3250	2150	1950	2850	1900	1700	6670
	Undercarriage: front empty – rear dozer – stabilized	*6850	*6850	6050	4900	*5500	3250	3250	*3950	2200	2800	*3150	1900	
	Undercarriage: front dozer – rear stabilizer – stabilized	*6850	*6850	*6850	*5500	*5500	5350	*3950	*3950	3550	*3150	*3150	3050	
	Undercarriage: front stabilizer – rear stabilizer – stabilized	*6850	*6850	*6850	*5500	*5500	*5500	*3950	*3950	*3950	*3150	*3150	*3150	

*Limited by hydraulic rather than tipping load.

Oscillating axle needs to be locked. Weight of all lifting accessories must be subtracted from the lifting capacities. All lift capacities calculated and rated per ISO 10567:2007. Rated loads do not exceed 87% of hydraulic lift capacity or 75% of tipping load. Heavy Lift Function ON. Lifting capacities are based on the machine standing on a firm uniform supporting surface. The load point is the center line of the bucket pivot mounting pin on the stick. Lift capacity is calculated with VA cylinder completely extracted. The use of a work tool attachment point to handle/lift objects, could affect the machine lift performance.

Always refer to the appropriate Operation and Maintenance Manual for specific product information.

M314 Wheeled Excavator Specifications

Lift Capacities – Variable Adjustable Boom (16'6"), 7'3" Stick

All values are in lb, work tool: none, bucket cylinder and bucket linkage installed, counterweight: 7,280 lb, heavy lift function on.

Stick height	Undercarriage configuration	10 ft			15 ft			20 ft			25 ft			ft			
		Load at maximum reach (sticknose/bucket pin)	Load over front	Load over rear	Load at maximum reach (sticknose/bucket pin)	Load over front	Load over rear	Load at maximum reach (sticknose/bucket pin)	Load over front	Load over rear	Load at maximum reach (sticknose/bucket pin)	Load over front	Load over rear				
25 ft	Undercarriage: front empty – rear dozer – free on wheels																
	Undercarriage: front empty – rear dozer – stabilized																
	Undercarriage: front dozer – rear stabilizer – stabilized																
	Undercarriage: front stabilizer – rear stabilizer – stabilized																
20 ft	Undercarriage: front empty – rear dozer – free on wheels																
	Undercarriage: front empty – rear dozer – stabilized																
	Undercarriage: front dozer – rear stabilizer – stabilized																
	Undercarriage: front stabilizer – rear stabilizer – stabilized																
15 ft	Undercarriage: front empty – rear dozer – free on wheels																
	Undercarriage: front empty – rear dozer – stabilized																
	Undercarriage: front dozer – rear stabilizer – stabilized																
	Undercarriage: front stabilizer – rear stabilizer – stabilized																
10 ft	Undercarriage: front empty – rear dozer – free on wheels																
	Undercarriage: front empty – rear dozer – stabilized																
	Undercarriage: front dozer – rear stabilizer – stabilized																
	Undercarriage: front stabilizer – rear stabilizer – stabilized																
5 ft	Undercarriage: front empty – rear dozer – free on wheels																
	Undercarriage: front empty – rear dozer – stabilized																
	Undercarriage: front dozer – rear stabilizer – stabilized																
	Undercarriage: front stabilizer – rear stabilizer – stabilized																
0 ft	Undercarriage: front empty – rear dozer – free on wheels																
	Undercarriage: front empty – rear dozer – stabilized																
	Undercarriage: front dozer – rear stabilizer – stabilized																
	Undercarriage: front stabilizer – rear stabilizer – stabilized																
-5 ft	Undercarriage: front empty – rear dozer – free on wheels																
	Undercarriage: front empty – rear dozer – stabilized																
	Undercarriage: front dozer – rear stabilizer – stabilized																
	Undercarriage: front stabilizer – rear stabilizer – stabilized																

*Limited by hydraulic rather than tipping load.

Oscillating axle needs to be locked. Weight of all lifting accessories must be subtracted from the lifting capacities. All lift capacities calculated and rated per ISO 10567:2007. Rated loads do not exceed 87% of hydraulic lift capacity or 75% of tipping load. Heavy Lift Function ON. Lifting capacities are based on the machine standing on a firm uniform supporting surface. The load point is the center line of the bucket pivot mounting pin on the stick. Lift capacity is calculated with VA cylinder completely extracted. The use of a work tool attachment point to handle/lift objects, could affect the machine lift performance.

Always refer to the appropriate Operation and Maintenance Manual for specific product information.

M314 Wheeled Excavator Specifications

Lift Capacities – Variable Adjustable Boom (5028 mm), 2500 mm Stick

All values are in kg, work tool: none, bucket cylinder and bucket linkage installed, counterweight: 3300 kg, heavy lift function on.

		Load at maximum reach (sticknose/bucket pin)			Load over front			Load over rear			Load over side			Load point height			
	Undercarriage configuration	3000 mm			4500 mm			6000 mm			7500 mm						mm
7500 mm	Undercarriage: front empty – rear dozer – free on wheels				*4100	*4100	3750							*3100	*3100	*3100	4990
	Undercarriage: front empty – rear dozer – stabilized				*4100	*4100	*4100							*3100	*3100	*3100	
	Undercarriage: front dozer – rear stabilizer – stabilized				*4100	*4100	*4100							*3100	*3100	*3100	
	Undercarriage: front stabilizer – rear stabilizer – stabilized				*4100	*4100	*4100							*3100	*3100	*3100	
6000 mm	Undercarriage: front empty – rear dozer – free on wheels				*4150	*4150	3800	*3700	2550	2350				*2650	2300	2100	6390
	Undercarriage: front empty – rear dozer – stabilized				*4150	*4150	*4150	3700	*3700	2600				*2650	*2650	*2650	
	Undercarriage: front dozer – rear stabilizer – stabilized				*4150	*4150	*4150	*3700	*3700	*3700				*2650	*2650	*2650	
	Undercarriage: front stabilizer – rear stabilizer – stabilized				*4150	*4150	*4150	*3700	*3700	*3700				*2650	*2650	*2650	
4500 mm	Undercarriage: front empty – rear dozer – free on wheels				*4750	4000	3650	3650	2550	2300				*2500	1850	1650	7200
	Undercarriage: front empty – rear dozer – stabilized				*4750	*4750	4050	3650	*4200	2600				*2500	*2500	1850	
	Undercarriage: front dozer – rear stabilizer – stabilized				*4750	*4750	*4750	*4200	*4200	3950				*2500	*2500	*2500	
	Undercarriage: front stabilizer – rear stabilizer – stabilized				*4750	*4750	*4750	*4200	*4200	*4200				*2500	*2500	*2500	
3000 mm	Undercarriage: front empty – rear dozer – free on wheels				5500	3700	3350	3550	2400	2200	2500	1700	1500	2450	1650	1500	7630
	Undercarriage: front empty – rear dozer – stabilized				5500	*5850	3750	3500	*4500	2450	2500	*3200	1700	2400	*2450	1650	
	Undercarriage: front dozer – rear stabilizer – stabilized				*5850	*5850	*5850	*4500	*4500	3800	*3200	*3200	2700	*2450	*2450	*2450	
	Undercarriage: front stabilizer – rear stabilizer – stabilized				*5850	*5850	*5850	*4500	*4500	*4500	*3200	*3200	*3200	*2450	*2450	*2450	
1500 mm	Undercarriage: front empty – rear dozer – free on wheels				5150	3400	3050	3400	2250	2050	2450	1650	1500	2350	1550	1400	7730
	Undercarriage: front empty – rear dozer – stabilized				5150	*6500	3450	3400	*4750	2300	2450	*3700	1650	2300	*2550	1600	
	Undercarriage: front dozer – rear stabilizer – stabilized				*6500	*6500	5600	*4750	*4750	3650	*3700	*3700	2650	*2550	*2550	2500	
	Undercarriage: front stabilizer – rear stabilizer – stabilized				*6500	*6500	*6500	*4750	*4750	4450	*3700	*3700	3200	*2550	*2550	*2550	
0 mm	Undercarriage: front empty – rear dozer – free on wheels				5000	3250	2900	3300	2150	1950	2400	1600	1450	2400	1600	1450	7530
	Undercarriage: front empty – rear dozer – stabilized				4950	*6500	3300	3300	*4700	2250	2400	*3100	1650	2400	*2850	1650	
	Undercarriage: front dozer – rear stabilizer – stabilized				*6500	*6500	5450	*4700	*4700	3550	*3100	*3100	2600	*2850	*2850	2600	
	Undercarriage: front stabilizer – rear stabilizer – stabilized				*6500	*6500	*6500	*4700	*4700	4350	*3100	*3100	*3100	*2850	*2850	*2850	
-1500 mm	Undercarriage: front empty – rear dozer – free on wheels	*6450	5950	5200	4950	3200	2850	3250	2150	1950				2650	1750	1600	6990
	Undercarriage: front empty – rear dozer – stabilized	*6450	*6450	6050	4900	*5750	3250	*4200	*4200	2200				2650	*3100	1800	
	Undercarriage: front dozer – rear stabilizer – stabilized	*6450	*6450	*6450	*5750	*5750	5400	*4200	*4200	3550				*3100	*3100	2900	
	Undercarriage: front stabilizer – rear stabilizer – stabilized	*6450	*6450	*6450	*5750	*5750	*5750	*4200	*4200	*4200				*3100	*3100	*3100	
-3000 mm	Undercarriage: front empty – rear dozer – free on wheels				*4200	3250	2900										
	Undercarriage: front empty – rear dozer – stabilized				*4200	*4200	3300										
	Undercarriage: front dozer – rear stabilizer – stabilized				*4200	*4200	*4200										
	Undercarriage: front stabilizer – rear stabilizer – stabilized				*4200	*4200	*4200										

*Limited by hydraulic rather than tipping load.

Oscillating axle needs to be locked. Weight of all lifting accessories must be subtracted from the lifting capacities. All lift capacities calculated and rated per ISO 10567:2007. Rated loads do not exceed 87% of hydraulic lift capacity or 75% of tipping load. Heavy Lift Function ON. Lifting capacities are based on the machine standing on a firm uniform supporting surface. The load point is the center line of the bucket pivot mounting pin on the stick. Lift capacity is calculated with VA cylinder completely extracted. The use of a work tool attachment point to handle/lift objects, could affect the machine lift performance.

Always refer to the appropriate Operation and Maintenance Manual for specific product information.

M314 Wheeled Excavator Specifications

Lift Capacities – Variable Adjustable Boom (16'6"), 8'2" Stick

All values are in lb, work tool: none, bucket cylinder and bucket linkage installed, counterweight: 7,280 lb, heavy lift function on.

		Load at maximum reach (sticknose/bucket pin)			Load over front			Load over rear			Load over side			Load point height					
	Undercarriage configuration	10 ft			15 ft			20 ft			25 ft								
																	ft		
25 ft	Undercarriage: front empty – rear dozer – free on wheels				*8,500	*8,500	8,000										*7,000	*7,000	*7,000
	Undercarriage: front empty – rear dozer – stabilized				*8,500	*8,500	*8,500										*7,000	*7,000	*7,000
	Undercarriage: front dozer – rear stabilizer – stabilized				*8,500	*8,500	*8,500										*7,000	*7,000	*7,000
	Undercarriage: front stabilizer – rear stabilizer – stabilized				*8,500	*8,500	*8,500										*7,000	*7,000	*7,000
20 ft	Undercarriage: front empty – rear dozer – free on wheels				*9,200	9,000	8,200	*7,500	5,500	5,000							*5,900	5,100	4,700
	Undercarriage: front empty – rear dozer – stabilized				*9,200	*9,200	9,100	*7,500	*7,500	5,600							*5,900	*5,900	5,200
	Undercarriage: front dozer – rear stabilizer – stabilized				*9,200	*9,200	*9,200	*7,500	*7,500	*7,500							*5,900	*5,900	*5,900
	Undercarriage: front stabilizer – rear stabilizer – stabilized				*9,200	*9,200	*9,200	*7,500	*7,500	*7,500							*5,900	*5,900	*5,900
15 ft	Undercarriage: front empty – rear dozer – free on wheels				*10,400	8,600	7,800	7,900	5,400	5,000							*5,500	4,100	3,700
	Undercarriage: front empty – rear dozer – stabilized				*10,400	*10,400	8,800	7,900	*9,100	5,500							*5,500	*5,500	4,200
	Undercarriage: front dozer – rear stabilizer – stabilized				*10,400	*10,400	*10,400	*9,100	*9,100	8,500							*5,500	*5,500	*5,500
	Undercarriage: front stabilizer – rear stabilizer – stabilized				*10,400	*10,400	*10,400	*9,100	*9,100	*9,100							*5,500	*5,500	*5,500
10 ft	Undercarriage: front empty – rear dozer – free on wheels				11,900	8,000	7,200	7,600	5,200	4,700	5,400	3,600	3,300	5,400	3,600	3,300	5,400	3,600	3,300
	Undercarriage: front empty – rear dozer – stabilized				11,800	*12,600	8,100	7,600	*9,700	5,300	5,300	*5,400	3,700	5,300	*5,400	3,700	5,300	*5,400	3,700
	Undercarriage: front dozer – rear stabilizer – stabilized				*12,600	*12,600	*12,600	*9,700	*9,700	8,200	*5,400	*5,400	*5,400	*5,400	*5,400	*5,400	*5,400	*5,400	*5,400
	Undercarriage: front stabilizer – rear stabilizer – stabilized				*12,600	*12,600	*12,600	*9,700	*9,700	*9,700	*5,400	*5,400	*5,400	*5,400	*5,400	*5,400	*5,400	*5,400	*5,400
5 ft	Undercarriage: front empty – rear dozer – free on wheels				11,100	7,300	6,600	7,300	4,900	4,400	5,300	3,500	3,200	5,100	3,400	3,100	5,100	3,400	3,100
	Undercarriage: front empty – rear dozer – stabilized				11,100	*14,000	7,500	7,300	*10,300	5,000	5,200	*7,300	3,600	5,100	*5,700	3,500	5,100	*5,700	3,500
	Undercarriage: front dozer – rear stabilizer – stabilized				*14,000	*14,000	12,100	*10,300	*10,300	7,900	*7,300	*7,300	5,700	*5,700	*5,700	5,600	*5,700	*5,700	5,600
	Undercarriage: front stabilizer – rear stabilizer – stabilized				*14,000	*14,000	*14,000	*10,300	*10,300	9,600	*7,300	*7,300	6,900	*5,700	*5,700	*5,700	*5,700	*5,700	*5,700
0 ft	Undercarriage: front empty – rear dozer – free on wheels				10,700	7,000	6,200	7,100	4,700	4,200				5,300	3,500	3,200	5,300	3,500	3,200
	Undercarriage: front empty – rear dozer – stabilized				10,700	*14,000	7,100	7,100	*10,200	4,800				5,300	*6,200	3,600	5,300	*6,200	3,600
	Undercarriage: front dozer – rear stabilizer – stabilized				*14,000	*14,000	11,700	*10,200	*10,200	7,700				*6,200	*6,200	5,700	*6,200	*6,200	5,700
	Undercarriage: front stabilizer – rear stabilizer – stabilized				*14,000	*14,000	*14,000	*10,200	*10,200	9,300				*6,200	*6,200	*6,200	*6,200	*6,200	*6,200
-5 ft	Undercarriage: front empty – rear dozer – free on wheels	*14,800	12,800	11,100	10,600	6,900	6,100	7,000	4,600	4,200				5,900	3,900	3,500	5,900	3,900	3,500
	Undercarriage: front empty – rear dozer – stabilized	*14,800	*14,800	13,000	10,600	*12,500	7,000	7,000	*9,000	4,700				5,900	*6,800	4,000	5,900	*6,800	4,000
	Undercarriage: front dozer – rear stabilizer – stabilized	*14,800	*14,800	*14,800	*12,500	*12,500	11,600	*9,000	*9,000	7,600				*6,800	*6,800	6,400	*6,800	*6,800	6,400
	Undercarriage: front stabilizer – rear stabilizer – stabilized	*14,800	*14,800	*14,800	*12,500	*12,500	*12,500	*9,000	*9,000	*9,000				*6,800	*6,800	*6,800	*6,800	*6,800	*6,800
-10 ft	Undercarriage: front empty – rear dozer – free on wheels				*9,000	7,000	6,300							*9,000	*9,000	7,200			
	Undercarriage: front empty – rear dozer – stabilized				*9,000	*9,000								*9,000	*9,000				
	Undercarriage: front dozer – rear stabilizer – stabilized				*9,000	*9,000	*9,000												
	Undercarriage: front stabilizer – rear stabilizer – stabilized				*9,000	*9,000	*9,000												

*Limited by hydraulic rather than tipping load.

Oscillating axle needs to be locked. Weight of all lifting accessories must be subtracted from the lifting capacities. All lift capacities calculated and rated per ISO 10567:2007. Rated loads do not exceed 87% of hydraulic lift capacity or 75% of tipping load. Heavy Lift Function ON. Lifting capacities are based on the machine standing on a firm uniform supporting surface. The load point is the center line of the bucket pivot mounting pin on the stick. Lift capacity is calculated with VA cylinder completely extracted. The use of a work tool attachment point to handle/lift objects, could affect the machine lift performance.

Always refer to the appropriate Operation and Maintenance Manual for specific product information.

M314 Wheeled Excavator Specifications

Lift Capacities – Variable Adjustable Boom (5028 mm), 2900 mm Industrial Stick

All values are in kg, work tool: none, bucket cylinder and bucket linkage installed, counterweight: 3300 kg, heavy lift function on.

		Load at maximum reach (sticknose/bucket pin)			Load over front			Load over rear			Load over side			Load point height					
	Undercarriage configuration	3000 mm			4500 mm			6000 mm			7500 mm								
																	mm		
7500 mm	Undercarriage: front empty – rear dozer – free on wheels				*4200	*4200	4050										*3500	3400	3100
	Undercarriage: front empty – rear dozer – stabilized				*4200	*4200	*4200										*3500	*3500	3450
	Undercarriage: front dozer – rear stabilizer – stabilized				*4200	*4200	*4200										*3500	*3500	*3500
	Undercarriage: front stabilizer – rear stabilizer – stabilized				*4200	*4200	*4200										*3500	*3500	*3500
6000 mm	Undercarriage: front empty – rear dozer – free on wheels				*4150	*4150	4050	3950	2800	2600							*3150	2400	2200
	Undercarriage: front empty – rear dozer – stabilized				*4150	*4150	*4150	3950	*4000	2850							*3150	*3150	2450
	Undercarriage: front dozer – rear stabilizer – stabilized				*4150	*4150	*4150	*4000	*4000	*4000							*3150	*3150	*3150
	Undercarriage: front stabilizer – rear stabilizer – stabilized				*4150	*4150	*4150	*4000	*4000	*4000							*3150	*3150	*3150
4500 mm	Undercarriage: front empty – rear dozer – free on wheels				*4600	4250	3900	3900	2750	2550							2800	1950	1800
	Undercarriage: front empty – rear dozer – stabilized				*4600	*4600	4350	3900	*4250	2800							2800	*3100	2000
	Undercarriage: front dozer – rear stabilizer – stabilized				*4600	*4600	*4600	*4250	*4250	4200							*3100	*3100	3000
	Undercarriage: front stabilizer – rear stabilizer – stabilized				*4600	*4600	*4600	*4250	*4250								*3100	*3100	*3100
3000 mm	Undercarriage: front empty – rear dozer – free on wheels				5800	4000	3600	3750	2650	2400	2700	1900	1750	2550	1800	1650			
	Undercarriage: front empty – rear dozer – stabilized				5750	*5800	4050	3750	*4600	2700	2700	*3800	1950	2550	*3200	1800			
	Undercarriage: front dozer – rear stabilizer – stabilized				*5800	*5800	*5800	*4600	*4600	4050	*3800	*3800	2900	*3200	*3200	2750			
	Undercarriage: front stabilizer – rear stabilizer – stabilized				*5800	*5800	*5800	*4600	*4600	*4600	*3800	*3800	3450	*3200	*3200	*3200			
1500 mm	Undercarriage: front empty – rear dozer – free on wheels				5450	3700	3350	3650	2500	2300	2650	1850	1700	2450	1700	1550			
	Undercarriage: front empty – rear dozer – stabilized				5450	*6650	3750	3600	*4900	2550	2650	3950	1900	2450	*3400	1750			
	Undercarriage: front dozer – rear stabilizer – stabilized				*6650	*6650	5900	*4900	*4900	3900	*3950	*3950	2850	*3400	*3400	2650			
	Undercarriage: front stabilizer – rear stabilizer – stabilized				*6650	*6650	*6650	*4900	*4900	4700	*3950	*3950	3400	*3400	*3400	3150			
0 mm	Undercarriage: front empty – rear dozer – free on wheels				5250	3500	3150	3500	2400	2200	2600	1800	1650	2500	1750	1600			
	Undercarriage: front empty – rear dozer – stabilized				5250	*6800	3550	3500	*5000	2450	2600	*3800	1850	2500	*3650	1750			
	Undercarriage: front dozer – rear stabilizer – stabilized				*6800	*6800	5700	*5000	*5000	3800	*3800	*3800	2800	*3650	*3650	2700			
	Undercarriage: front stabilizer – rear stabilizer – stabilized				*6800	*6800	*6800	*5000	*5000	4550	*3800	*3800	3350	*3650	*3650	3200			
-1500 mm	Undercarriage: front empty – rear dozer – free on wheels	*7350	6200	5450	5200	3400	3100	3450	2350	2150				2750	1850	1700			
	Undercarriage: front empty – rear dozer – stabilized	*7350	*7350	6300	5150	*6300	3500	3450	*4650	2400				2700	*3500	1900			
	Undercarriage: front dozer – rear stabilizer – stabilized	*7350	*7350	*7350	*6300	*6300	5650	*4650	*4650	3750				*3500	*3500	2950			
	Undercarriage: front stabilizer – rear stabilizer – stabilized	*7350	*7350	*7350	*6300	*6300	*6300	*4650	*4650	4500				*3500	*3500	*3500			
-3000 mm	Undercarriage: front empty – rear dozer – free on wheels				*5000	3450	3100	3500	2400	2150				*3200	2250	2050			
	Undercarriage: front empty – rear dozer – stabilized				*5000	*5000	3500	3500	*3500	2450				*3200	*3200	2300			
	Undercarriage: front dozer – rear stabilizer – stabilized				*5000	*5000	*5000	*3500	*3500	*3500				*3200	*3200	*3200			
	Undercarriage: front stabilizer – rear stabilizer – stabilized				*5000	*5000	*5000	*3500	*3500	*3500				*3200	*3200	*3200			

*Limited by hydraulic rather than tipping load.

Oscillating axle needs to be locked. Weight of all lifting accessories must be subtracted from the lifting capacities. All lift capacities calculated and rated per ISO 10567:2007. Rated loads do not exceed 87% of hydraulic lift capacity or 75% of tipping load. Heavy Lift Function ON. Lifting capacities are based on the machine standing on a firm uniform supporting surface. The load point is the center line of the bucket pivot mounting pin on the stick. Lift capacity is calculated with VA cylinder completely extracted. The use of a work tool attachment point to handle/lift objects, could affect the machine lift performance.

Always refer to the appropriate Operation and Maintenance Manual for specific product information.

M314 Wheeled Excavator Specifications

Lift Capacities – Variable Adjustable Boom (16'6"), 9'6" Industrial Stick

All values are in lb, work tool: none, bucket cylinder and bucket linkage installed, counterweight: 7,280 lb, heavy lift function on.

		Load at maximum reach (sticknose/bucket pin)			Load over front			Load over rear			Load over side			Load point height					
	Undercarriage configuration	10 ft			15 ft			20 ft			25 ft								
																	ft		
25 ft	Undercarriage: front empty – rear dozer – free on wheels				*9,200	*9,200	8,700										*7,800	7,800	7,200
	Undercarriage: front empty – rear dozer – stabilized				*9,200	*9,200	*9,200										*7,800	*7,800	*7,800
	Undercarriage: front dozer – rear stabilizer – stabilized				*9,200	*9,200	*9,200										*7,800	*7,800	*7,800
	Undercarriage: front stabilizer – rear stabilizer – stabilized				*9,200	*9,200	*9,200										*7,800	*7,800	*7,800
20 ft	Undercarriage: front empty – rear dozer – free on wheels				*9,200	*9,200	8,700	8,500	6,000	5,600							*7,000	5,300	4,900
	Undercarriage: front empty – rear dozer – stabilized				*9,200	*9,200	*9,200	8,500	*8,500	6,100							*7,000	*7,000	5,400
	Undercarriage: front dozer – rear stabilizer – stabilized				*9,200	*9,200	*9,200	*8,500	*8,500	*8,500							*7,000	*7,000	*7,000
	Undercarriage: front stabilizer – rear stabilizer – stabilized				*9,200	*9,200	*9,200	*8,500	*8,500	*8,500							*7,000	*7,000	*7,000
15 ft	Undercarriage: front empty – rear dozer – free on wheels				*10,100	9,200	8,400	8,400	5,900	5,500							6,200	4,400	4,000
	Undercarriage: front empty – rear dozer – stabilized				*10,100	*10,100	9,300	8,400	*9,200	6,000							6,200	*6,800	4,500
	Undercarriage: front dozer – rear stabilizer – stabilized				*10,100	*10,100	*10,100	*9,200	*9,200	9,000							*6,800	*6,800	6,700
	Undercarriage: front stabilizer – rear stabilizer – stabilized				*10,100	*10,100	*10,100	*9,200	*9,200	*9,200							*6,800	*6,800	*6,800
10 ft	Undercarriage: front empty – rear dozer – free on wheels				12,500	8,600	7,800	8,100	5,700	5,200	5,900	4,100	3,800	5,600	3,900	3,600	5,600	3,900	3,600
	Undercarriage: front empty – rear dozer – stabilized				12,400	*12,600	8,700	8,100	*10,000	5,800	5,800	*8,200	4,200	5,600	*7,000	4,000	5,600	*7,000	4,000
	Undercarriage: front dozer – rear stabilizer – stabilized				*12,600	*12,600	*12,600	*10,000	*10,000	8,700	*8,200	*8,200	6,300	*7,000	*7,000	6,000	*7,000	*7,000	6,000
	Undercarriage: front stabilizer – rear stabilizer – stabilized				*12,600	*12,600	*12,600	*10,000	*10,000	*10,000	*8,200	*8,200	7,400	*7,000	*7,000	*7,000	*7,000	*7,000	*7,000
5 ft	Undercarriage: front empty – rear dozer – free on wheels				11,800	8,000	7,200	7,800	5,400	4,900	5,700	4,000	3,600	5,400	3,700	3,400	5,400	3,700	3,400
	Undercarriage: front empty – rear dozer – stabilized				11,700	*14,300	8,100	7,800	*10,600	5,500	5,700	8,500	4,100	5,400	*7,500	3,800	5,400	*7,500	3,800
	Undercarriage: front dozer – rear stabilizer – stabilized				*14,300	*14,300	12,800	*10,600	*10,600	8,400	*8,500	*8,500	6,100	*7,500	*7,500	5,800	*7,500	*7,500	5,800
	Undercarriage: front stabilizer – rear stabilizer – stabilized				*14,300	*14,300	*14,300	*10,600	*10,600	10,100	*8,500	*8,500	7,300	*7,500	*7,500	6,900	*7,500	*7,500	6,900
0 ft	Undercarriage: front empty – rear dozer – free on wheels				11,300	7,500	6,800	7,600	5,200	4,700	5,600	3,900	3,500	5,500	3,800	3,500	5,500	3,800	3,500
	Undercarriage: front empty – rear dozer – stabilized				11,300	*14,800	7,700	7,600	*10,800	5,300	5,600	*8,200	4,000	5,500	*8,000	3,900	5,500	*8,000	3,900
	Undercarriage: front dozer – rear stabilizer – stabilized				*14,800	*14,800	12,300	*10,800	*10,800	8,200	*8,200	*8,200	6,000	*8,000	*8,000	5,900	*8,000	*8,000	5,900
	Undercarriage: front stabilizer – rear stabilizer – stabilized				*14,800	*14,800	*14,800	*10,800	*10,800	9,800	*8,200	*8,200	7,200	*8,000	*8,000	7,100	*8,000	*8,000	7,100
-5 ft	Undercarriage: front empty – rear dozer – free on wheels	*16,700	13,400	11,700	11,200	7,400	6,700	7,500	5,100	4,600				6,000	4,100	3,800	6,000	4,100	3,800
	Undercarriage: front empty – rear dozer – stabilized	*16,700	*16,700	13,600	11,100	*13,600	7,500	7,400	*10,000	5,200				6,000	*7,700	4,200	6,000	*7,700	4,200
	Undercarriage: front dozer – rear stabilizer – stabilized	*16,700	*16,700	*16,700	*13,600	*13,600	12,100	*10,000	*10,000	8,100				*7,700	*7,700	6,500	*7,700	*7,700	6,500
	Undercarriage: front stabilizer – rear stabilizer – stabilized	*16,700	*16,700	*16,700	*13,600	*13,600	*13,600	*10,000	*10,000	9,700				*7,700	*7,700	*7,700	*7,700	*7,700	*7,700
-10 ft	Undercarriage: front empty – rear dozer – free on wheels				*10,700	7,500	6,700	*7,300	5,100	4,700				*7,000	5,000	4,600	*7,000	5,000	4,600
	Undercarriage: front empty – rear dozer – stabilized				*10,700	*10,700	7,600	*7,300	*7,300	5,300				*7,000	*7,000	5,100	*7,000	*7,000	5,100
	Undercarriage: front dozer – rear stabilizer – stabilized				*10,700	*10,700	*10,700	*7,300	*7,300	*7,300				*7,000	*7,000	*7,000	*7,000	*7,000	*7,000
	Undercarriage: front stabilizer – rear stabilizer – stabilized				*10,700	*10,700	*10,700	*7,300	*7,300	*7,300				*7,000	*7,000	*7,000	*7,000	*7,000	*7,000

*Limited by hydraulic rather than tipping load.

Oscillating axle needs to be locked. Weight of all lifting accessories must be subtracted from the lifting capacities. All lift capacities calculated and rated per ISO 10567:2007. Rated loads do not exceed 87% of hydraulic lift capacity or 75% of tipping load. Heavy Lift Function ON. Lifting capacities are based on the machine standing on a firm uniform supporting surface. The load point is the center line of the bucket pivot mounting pin on the stick. Lift capacity is calculated with VA cylinder completely extracted. The use of a work tool attachment point to handle/lift objects, could affect the machine lift performance.

Always refer to the appropriate Operation and Maintenance Manual for specific product information.

M314 Wheeled Excavator Specifications

Lift Capacities – One-Piece Boom (4650 mm), 2200 mm Stick

All values are in kg, work tool: none, bucket cylinder and bucket linkage installed, counterweight: 3300 kg, heavy lift function on.

Stick point height	Undercarriage configuration	3000 mm			4500 mm			6000 mm			Stick point height			mm
		Load over front	Load over rear	Load over side	Load over front	Load over rear	Load over side	Load over front	Load over rear	Load over side	Load over front	Load over rear	Load over side	
6000 mm	Undercarriage: front empty – rear dozer – free on wheels				*4700	4100	3750				*3000	2950	2700	5460
	Undercarriage: front empty – rear dozer – stabilized				*4700	*4700	4150				*3000	*3000	*3000	
	Undercarriage: front dozer – rear stabilizer – stabilized				*4700	*4700	*4700				*3000	*3000	*3000	
	Undercarriage: front stabilizer – rear stabilizer – stabilized				*4700	*4700	*4700				*3000	*3000	*3000	
4500 mm	Undercarriage: front empty – rear dozer – free on wheels				*5200	4000	3650	3650	2500	2300	*2800	2250	2050	6400
	Undercarriage: front empty – rear dozer – stabilized				*5200	*5200	4050	3600	*4300	2550	*2800	*2800	2300	
	Undercarriage: front dozer – rear stabilizer – stabilized				*5200	*5200	*5200	*4300	*4300	3900	*2800	*2800	*2800	
	Undercarriage: front stabilizer – rear stabilizer – stabilized				*5200	*5200	*5200	*4300	*4300	*4300	*2800	*2800	*2800	
3000 mm	Undercarriage: front empty – rear dozer – free on wheels				5500	3750	3400	3550	2450	2200	*2800	1950	1800	6870
	Undercarriage: front empty – rear dozer – stabilized				5500	*6000	3800	3550	*4700	2500	*2800	*2800	2000	
	Undercarriage: front dozer – rear stabilizer – stabilized				*6000	*6000	5950	*4700	*4700	3800	*2800	*2800	*2800	
	Undercarriage: front stabilizer – rear stabilizer – stabilized				*6000	*6000	*6000	*4700	*4700	4600	*2800	*2800	*2800	
1500 mm	Undercarriage: front empty – rear dozer – free on wheels				5250	3500	3150	3450	2300	2100	2750	1850	1700	6990
	Undercarriage: front empty – rear dozer – stabilized				5200	*6650	3550	3400	*4900	2350	2700	*3000	1900	
	Undercarriage: front dozer – rear stabilizer – stabilized				*6650	*6650	5700	*4900	*4900	3700	*3000	*3000	2950	
	Undercarriage: front stabilizer – rear stabilizer – stabilized				*6650	*6650	*6650	*4900	*4900	4450	*3000	*3000	*3000	
0 mm	Undercarriage: front empty – rear dozer – free on wheels	*5300	*5300	*5300	5050	3350	3000	3350	2250	2050	2850	1900	1750	6760
	Undercarriage: front empty – rear dozer – stabilized	*5300	*5300	*5300	5050	*6600	3400	3350	*4750	2300	2800	*3450	1950	
	Undercarriage: front dozer – rear stabilizer – stabilized	*5300	*5300	*5300	*6600	*6600	5500	*4750	*4750	3600	*3450	*3450	3050	
	Undercarriage: front stabilizer – rear stabilizer – stabilized	*5300	*5300	*5300	*6600	*6600	*6600	*4750	*4750	4350	*3450	*3450	*3450	
-1500 mm	Undercarriage: front empty – rear dozer – free on wheels	*7900	6150	5350	5050	3300	2950	3350	2250	2050	3250	2150	1950	6150
	Undercarriage: front empty – rear dozer – stabilized	*7900	*7900	6200	5000	*5750	3350	3300	*3900	2300	3200	*3650	2200	
	Undercarriage: front dozer – rear stabilizer – stabilized	*7900	*7900	*7900	*5750	*5750	5450	*3900	*3900	3600	*3650	*3650	3500	
	Undercarriage: front stabilizer – rear stabilizer – stabilized	*7900	*7900	*7900	*5750	*5750	*5750	*3900	*3900	*3900	*3650	*3650	*3650	
-3000 mm	Undercarriage: front empty – rear dozer – free on wheels	*5100	*5100	*5100	*3700	3400	3050				*2900	*2900	2650	5010
	Undercarriage: front empty – rear dozer – stabilized	*5100	*5100	*5100	*3700	*3700	3450				*2900	*2900	*2900	
	Undercarriage: front dozer – rear stabilizer – stabilized	*5100	*5100	*5100	*3700	*3700	*3700				*2900	*2900	*2900	
	Undercarriage: front stabilizer – rear stabilizer – stabilized	*5100	*5100	*5100	*3700	*3700	*3700				*2900	*2900	*2900	

*Limited by hydraulic rather than tipping load.

Oscillating axle needs to be locked. Weight of all lifting accessories must be subtracted from the lifting capacities. All lift capacities calculated and rated per ISO 10567:2007. Rated loads do not exceed 87% of hydraulic lift capacity or 75% of tipping load. Heavy Lift Function ON. Lifting capacities are based on the machine standing on a firm uniform supporting surface. The load point is the center line of the bucket pivot mounting pin on the stick. The use of a work tool attachment point to handle/lift objects, could affect the machine lift performance.

Always refer to the appropriate Operation and Maintenance Manual for specific product information.

M314 Wheeled Excavator Specifications

Lift Capacities – One-Piece Boom (15'3"), 7'3" Stick

All values are in lb, work tool: none, bucket cylinder and bucket linkage installed, counterweight: 7,280 lb, heavy lift function on.

		Load at maximum reach (sticknose/bucket pin)			Load over front			Load over rear			Load over side			Load point height		
	Undercarriage configuration	10 ft			15 ft			20 ft						ft		
20 ft	Undercarriage: front empty – rear dozer – free on wheels				*10,200	8,800	8,000				*6,700	6,700	6,100	17.62		
	Undercarriage: front empty – rear dozer – stabilized				*10,200	*10,200	8,900				*6,700	*6,700	*6,700			
	Undercarriage: front dozer – rear stabilizer – stabilized				*10,200	*10,200	*10,200				*6,700	*6,700	*6,700			
	Undercarriage: front stabilizer – rear stabilizer – stabilized				*10,200	*10,200	*10,200				*6,700	*6,700	*6,700			
15 ft	Undercarriage: front empty – rear dozer – free on wheels				*11,300	8,600	7,800	7,800	5,400	4,900	*6,200	5,000	4,600	20.87		
	Undercarriage: front empty – rear dozer – stabilized				*11,300	*11,300	8,700	7,800	*8,700	5,500	*6,200	*6,200	5,100			
	Undercarriage: front dozer – rear stabilizer – stabilized				*11,300	*11,300	*11,300	*8,700	*8,700	8,400	*6,200	*6,200	*6,200			
	Undercarriage: front stabilizer – rear stabilizer – stabilized				*11,300	*11,300	*11,300	*8,700	*8,700	*8,700	*6,200	*6,200	*6,200			
10 ft	Undercarriage: front empty – rear dozer – free on wheels				11,900	8,100	7,300	7,600	5,200	4,800	*6,200	4,300	3,900	22.54		
	Undercarriage: front empty – rear dozer – stabilized				11,800	*13,000	8,200	7,600	*10,200	5,300	*6,200	*6,200	4,400			
	Undercarriage: front dozer – rear stabilizer – stabilized				*13,000	*13,000	12,800	*10,200	*10,200	8,200	*6,200	*6,200	*6,200			
	Undercarriage: front stabilizer – rear stabilizer – stabilized				*13,000	*13,000	*13,000	*10,200	*10,200	9,900	*6,200	*6,200	*6,200			
5 ft	Undercarriage: front empty – rear dozer – free on wheels				11,300	7,500	6,800	7,400	5,000	4,600	6,000	4,100	3,700	22.93		
	Undercarriage: front empty – rear dozer – stabilized				11,200	*14,400	7,700	7,400	*10,600	5,100	6,000	*6,600	4,200			
	Undercarriage: front dozer – rear stabilizer – stabilized				*14,400	*14,400	12,200	*10,600	*10,600	8,000	*6,600	*6,600	6,500			
	Undercarriage: front stabilizer – rear stabilizer – stabilized				*14,400	*14,400	*14,400	*10,600	*10,600	9,600	*6,600	*6,600	*6,600			
0 ft	Undercarriage: front empty – rear dozer – free on wheels	*12,200	*12,200	11,500	10,900	7,200	6,500	7,200	4,800	4,400	6,200	4,200	3,800	22.18		
	Undercarriage: front empty – rear dozer – stabilized	*12,200	*12,200	*12,200	10,900	*14,400	7,300	7,200	*10,300	5,000	6,200	*7,600	4,300			
	Undercarriage: front dozer – rear stabilizer – stabilized	*12,200	*12,200	*12,200	*14,400	*14,400	11,900	*10,300	*10,300	7,800	*7,600	*7,600	6,700			
	Undercarriage: front stabilizer – rear stabilizer – stabilized	*12,200	*12,200	*12,200	*14,400	*14,400	*14,400	*10,300	*10,300	9,400	*7,600	*7,600	*7,600			
-5 ft	Undercarriage: front empty – rear dozer – free on wheels	*17,200	13,200	11,500	10,800	7,100	6,400	7,200	4,800	4,400	7,100	4,800	4,400	20.14		
	Undercarriage: front empty – rear dozer – stabilized	*17,200	*17,200	13,300	10,800	*12,400	7,300	7,200	*8,200	4,900	7,100	*8,100	4,900			
	Undercarriage: front dozer – rear stabilizer – stabilized	*17,200	*17,200	*17,200	*12,400	*12,400	11,800	*8,200	*8,200	7,800	*8,100	*8,100	7,700			
	Undercarriage: front stabilizer – rear stabilizer – stabilized	*17,200	*17,200	*17,200	*12,400	*12,400	*12,400	*8,200	*8,200	*8,200	*8,100	*8,100	*8,100			
-10 ft	Undercarriage: front empty – rear dozer – free on wheels	*10,900	*10,900	*10,900	*7,700	7,300	6,600				*6,300	*6,300	6,000	16.27		
	Undercarriage: front empty – rear dozer – stabilized	*10,900	*10,900	*10,900	*7,700	*7,700	7,500				*6,300	*6,300	*6,300			
	Undercarriage: front dozer – rear stabilizer – stabilized	*10,900	*10,900	*10,900	*7,700	*7,700	*7,700				*6,300	*6,300	*6,300			
	Undercarriage: front stabilizer – rear stabilizer – stabilized	*10,900	*10,900	*10,900	*7,700	*7,700	*7,700				*6,300	*6,300	*6,300			

*Limited by hydraulic rather than tipping load.

Oscillating axle needs to be locked. Weight of all lifting accessories must be subtracted from the lifting capacities. All lift capacities calculated and rated per ISO 10567:2007. Rated loads do not exceed 87% of hydraulic lift capacity or 75% of tipping load. Heavy Lift Function ON. Lifting capacities are based on the machine standing on a firm uniform supporting surface. The load point is the center line of the bucket pivot mounting pin on the stick. The use of a work tool attachment point to handle/lift objects, could affect the machine lift performance.

Always refer to the appropriate Operation and Maintenance Manual for specific product information.

M314 Wheeled Excavator Specifications

Lift Capacities – One-Piece Boom (4650 mm), 2500 mm Stick

All values are in kg, work tool: none, bucket cylinder and bucket linkage installed, counterweight: 3300 kg, heavy lift function on.

Stick height	Undercarriage configuration	3000 mm			4500 mm			6000 mm			Load point height			mm
		Load at maximum reach (sticknose/bucket pin)	Load over front	Load over rear	Load over front	Load over rear	Load over side	Load at maximum reach (sticknose/bucket pin)	Load over front	Load over rear	Load over front	Load over rear	Load over side	
7500 mm	Undercarriage: front empty – rear dozer – free on wheels										*3100	*3100	*3100	4210
	Undercarriage: front empty – rear dozer – stabilized										*3100	*3100	*3100	
	Undercarriage: front dozer – rear stabilizer – stabilized										*3100	*3100	*3100	
	Undercarriage: front stabilizer – rear stabilizer – stabilized										*3100	*3100	*3100	
6000 mm	Undercarriage: front empty – rear dozer – free on wheels										*2600	*2600	2450	5820
	Undercarriage: front empty – rear dozer – stabilized										*2600	*2600	*2600	
	Undercarriage: front dozer – rear stabilizer – stabilized										*2600	*2600	*2600	
	Undercarriage: front stabilizer – rear stabilizer – stabilized										*2600	*2600	*2600	
4500 mm	Undercarriage: front empty – rear dozer – free on wheels				*4750	4050	3700	3700	2550	2350	*2450	2100	1950	6700
	Undercarriage: front empty – rear dozer – stabilized				*4750	*4750	4100	3650	*4100	2600	*2450	*2450	2150	
	Undercarriage: front dozer – rear stabilizer – stabilized				*4750	*4750	*4750	*4100	*4100	3950	*2450	*2450	*2450	
	Undercarriage: front stabilizer – rear stabilizer – stabilized				*4750	*4750	*4750	*4100	*4100	*4100	*2450	*2450	*2450	
3000 mm	Undercarriage: front empty – rear dozer – free on wheels	*8800	7100	6300	5600	3800	3450	3600	2450	2250	*2450	1850	1700	7160
	Undercarriage: front empty – rear dozer – stabilized	*8800	*8800	7200	5550	*5800	3850	3550	*4600	2500	*2450	*2450	1900	
	Undercarriage: front dozer – rear stabilizer – stabilized	*8800	*8800	*8800	*5800	*5800	*5800	*4600	*4600	3850	*2450	*2450	*2450	
	Undercarriage: front stabilizer – rear stabilizer – stabilized	*8800	*8800	*8800	*5800	*5800	*5800	*4600	*4600	*4600	*2450	*2450	*2450	
1500 mm	Undercarriage: front empty – rear dozer – free on wheels				5300	3550	3200	3450	2350	2150	*2600	1750	1600	7270
	Undercarriage: front empty – rear dozer – stabilized				5300	*6600	3600	3450	*4850	2400	2600	*2600	1800	
	Undercarriage: front dozer – rear stabilizer – stabilized				*6600	*6600	5750	*4850	*4850	3750	*2600	*2600	*2600	
	Undercarriage: front stabilizer – rear stabilizer – stabilized				*6600	*6600	*6600	*4850	*4850	4500	*2600	*2600	*2600	
0 mm	Undercarriage: front empty – rear dozer – free on wheels	*5550	*5550	5350	5100	3350	3050	3350	2250	2050	2700	1800	1650	7050
	Undercarriage: front empty – rear dozer – stabilized	*5550	*5550	*5550	5100	*6700	3450	3350	*4850	2300	2650	*2950	1850	
	Undercarriage: front dozer – rear stabilizer – stabilized	*5550	*5550	*5550	*6700	*6700	5550	*4850	*4850	3650	*2950	*2950	2900	
	Undercarriage: front stabilizer – rear stabilizer – stabilized	*5550	*5550	*5550	*6700	*6700	*6700	*4850	*4850	4400	*2950	*2950	*2950	
-1500 mm	Undercarriage: front empty – rear dozer – free on wheels	*8550	6150	5350	5050	3300	3000	3350	2250	2050	3000	2050	1850	6470
	Undercarriage: front empty – rear dozer – stabilized	*8550	*8550	6200	5050	*6000	3400	3300	*4200	2300	3000	*3600	2100	
	Undercarriage: front dozer – rear stabilizer – stabilized	*8550	*8550	*8550	*6000	*6000	5500	*4200	*4200	3600	*3600	*3600	3250	
	Undercarriage: front stabilizer – rear stabilizer – stabilized	*8550	*8550	*8550	*6000	*6000	*6000	*4200	*4200	*4200	*3600	*3600	*3600	
-3000 mm	Undercarriage: front empty – rear dozer – free on wheels	*5900	*5900	5500	*4250	3350	3050				*3050	2650	2400	5400
	Undercarriage: front empty – rear dozer – stabilized	*5900	*5900	*5900	*4250	*4250	3450				*3050	*3050	2700	
	Undercarriage: front dozer – rear stabilizer – stabilized	*5900	*5900	*5900	*4250	*4250	*4250				*3050	*3050	*3050	
	Undercarriage: front stabilizer – rear stabilizer – stabilized	*5900	*5900	*5900	*4250	*4250	*4250				*3050	*3050	*3050	

*Limited by hydraulic rather than tipping load.

Oscillating axle needs to be locked. Weight of all lifting accessories must be subtracted from the lifting capacities. All lift capacities calculated and rated per ISO 10567:2007. Rated loads do not exceed 87% of hydraulic lift capacity or 75% of tipping load. Heavy Lift Function ON. Lifting capacities are based on the machine standing on a firm uniform supporting surface. The load point is the center line of the bucket pivot mounting pin on the stick. The use of a work tool attachment point to handle/lift objects, could affect the machine lift performance.

Always refer to the appropriate Operation and Maintenance Manual for specific product information.

M314 Wheeled Excavator Specifications

Lift Capacities – One-Piece Boom (15'3"), 8'2" Stick

All values are in lb, work tool: none, bucket cylinder and bucket linkage installed, counterweight: 7,280 lb, heavy lift function on.

		Load at maximum reach (sticknose/bucket pin)			Load over front			Load over rear			Load over side			Load point height	
	Undercarriage configuration	10 ft			15 ft			20 ft						ft	
20 ft	Undercarriage: front empty – rear dozer – free on wheels										*5,700	*5,700	5,600	18.83	
	Undercarriage: front empty – rear dozer – stabilized										*5,700	*5,700	*5,700		
	Undercarriage: front dozer – rear stabilizer – stabilized										*5,700	*5,700	*5,700		
	Undercarriage: front stabilizer – rear stabilizer – stabilized										*5,700	*5,700	*5,700		
15 ft	Undercarriage: front empty – rear dozer – free on wheels				*10,300	8,700	8,000	7,900	5,500	5,000	*5,400	4,700	4,300	21.88	
	Undercarriage: front empty – rear dozer – stabilized				*10,300	*10,300	8,900	7,900	*8,700	5,600	*5,400	*5,400	4,800		
	Undercarriage: front dozer – rear stabilizer – stabilized				*10,300	*10,300	*10,300	*8,700	*8,700	8,500	*5,400	*5,400	*5,400		
	Undercarriage: front stabilizer – rear stabilizer – stabilized				*10,300	*10,300	*10,300	*8,700	*8,700	*8,700	*5,400	*5,400	*5,400		
10 ft	Undercarriage: front empty – rear dozer – free on wheels	*18,900	15,400	15,400	12,000	8,200	7,500	7,700	5,300	4,900	*5,400	4,100	3,700	23.46	
	Undercarriage: front empty – rear dozer – stabilized	*18,900	*18,900	15,500	12,000	*12,600	8,400	7,700	*10,000	5,400	*5,400	*5,400	4,200		
	Undercarriage: front dozer – rear stabilizer – stabilized	*18,900	*18,900	*18,900	*12,600	*12,600	*12,600	*10,000	*10,000	8,300	*5,400	*5,400	*5,400		
	Undercarriage: front stabilizer – rear stabilizer – stabilized	*18,900	*18,900	*18,900	*12,600	*12,600	*12,600	*10,000	*10,000	9,900	*5,400	*5,400	*5,400		
5 ft	Undercarriage: front empty – rear dozer – free on wheels	*11,100	*11,100	*11,100	11,400	7,600	6,900	7,500	5,100	4,600	*5,700	3,900	3,500	23.85	
	Undercarriage: front empty – rear dozer – stabilized	*11,100	*11,100	*11,100	11,400	*14,300	7,800	7,400	*10,500	5,200	*5,700	*5,700	4,000		
	Undercarriage: front dozer – rear stabilizer – stabilized	*11,100	*11,100	*11,100	*14,300	*14,300	12,400	*10,500	*10,500	8,000	*5,700	*5,700	*5,700		
	Undercarriage: front stabilizer – rear stabilizer – stabilized	*11,100	*11,100	*11,100	*14,300	*14,300	*14,300	*10,500	*10,500	9,700	*5,700	*5,700	*5,700		
0 ft	Undercarriage: front empty – rear dozer – free on wheels	*12,800	*12,800	11,600	11,000	7,300	6,500	7,300	4,900	4,400	5,900	4,000	3,600	23.13	
	Undercarriage: front empty – rear dozer – stabilized	*12,800	*12,800	*12,800	11,000	*14,500	7,400	7,200	*10,500	5,000	5,900	*6,500	4,100		
	Undercarriage: front dozer – rear stabilizer – stabilized	*12,800	*12,800	*12,800	*14,500	*14,500	11,900	*10,500	*10,500	7,800	*6,500	*6,500	6,400		
	Undercarriage: front stabilizer – rear stabilizer – stabilized	*12,800	*12,800	*12,800	*14,500	*14,500	*14,500	*10,500	*10,500	9,500	*6,500	*6,500	*6,500		
-5 ft	Undercarriage: front empty – rear dozer – free on wheels	*18,600	13,200	11,600	10,900	7,100	6,400	7,200	4,800	4,400	6,700	4,500	4,100	21.19	
	Undercarriage: front empty – rear dozer – stabilized	*18,600	*18,600	13,400	10,800	*13,000	7,300	7,200	*9,000	4,900	6,600	*7,900	4,600		
	Undercarriage: front dozer – rear stabilizer – stabilized	*18,600	*18,600	*18,600	*13,000	*13,000	11,800	*9,000	*9,000	7,800	*7,900	*7,900	7,200		
	Undercarriage: front stabilizer – rear stabilizer – stabilized	*18,600	*18,600	*18,600	*13,000	*13,000	*13,000	*9,000	*9,000	*9,000	*7,900	*7,900	*7,900		
-10 ft	Undercarriage: front empty – rear dozer – free on wheels	*12,700	*12,700	11,800	*9,000	7,300	6,600				*6,600	5,900	5,300	17.59	
	Undercarriage: front empty – rear dozer – stabilized	*12,700	*12,700	*12,700	*9,000	*9,000	7,400				*6,600	*6,600	6,000		
	Undercarriage: front dozer – rear stabilizer – stabilized	*12,700	*12,700	*12,700	*9,000	*9,000	*9,000				*6,600	*6,600	*6,600		
	Undercarriage: front stabilizer – rear stabilizer – stabilized	*12,700	*12,700	*12,700	*9,000	*9,000	*9,000				*6,600	*6,600	*6,600		

*Limited by hydraulic rather than tipping load.

Oscillating axle needs to be locked. Weight of all lifting accessories must be subtracted from the lifting capacities. All lift capacities calculated and rated per ISO 10567:2007. Rated loads do not exceed 87% of hydraulic lift capacity or 75% of tipping load. Heavy Lift Function ON. Lifting capacities are based on the machine standing on a firm uniform supporting surface. The load point is the center line of the bucket pivot mounting pin on the stick. The use of a work tool attachment point to handle/lift objects, could affect the machine lift performance.

Always refer to the appropriate Operation and Maintenance Manual for specific product information.

M314 Wheeled Excavator Specifications

Lift Capacities – One-Piece Boom (4650 mm), 2900 mm Industrial Stick

All values are in kg, work tool: none, bucket cylinder and bucket linkage installed, counterweight: 3300 kg, heavy lift function on.

		Load at maximum reach (sticknose/bucket pin)			Load over front			Load over rear			Load over side			Load point height	
	Undercarriage configuration	3000 mm			4500 mm			6000 mm						mm	
6000 mm	Undercarriage: front empty – rear dozer – free on wheels										*3150	2800	2600	6000	
	Undercarriage: front empty – rear dozer – stabilized										*3150	*3150	2850		
	Undercarriage: front dozer – rear stabilizer – stabilized										*3150	*3150	*3150		
	Undercarriage: front stabilizer – rear stabilizer – stabilized										*3150	*3150	*3150		
4500 mm	Undercarriage: front empty – rear dozer – free on wheels							3900	2800	2550	*3100	2250	2100	6860	
	Undercarriage: front empty – rear dozer – stabilized							3900	*4300	2850	*3100	*3100	2300		
	Undercarriage: front dozer – rear stabilizer – stabilized							*4300	*4300	4200	*3100	*3100	*3100		
	Undercarriage: front stabilizer – rear stabilizer – stabilized							*4300	*4300	*4300	*3100	*3100	*3100		
3000 mm	Undercarriage: front empty – rear dozer – free on wheels	*8250	7550	6750	*5750	4050	3700	3800	2700	2500	2850	2000	1850	7310	
	Undercarriage: front empty – rear dozer – stabilized	*8250	*8250	7650	*5750	*5750	4150	3800	*4650	2750	2850	*3200	2050		
	Undercarriage: front dozer – rear stabilizer – stabilized	*8250	*8250	*8250	*5750	*5750	*5750	*4650	*4650	4100	*3200	*3200	3050		
	Undercarriage: front stabilizer – rear stabilizer – stabilized	*8250	*8250	*8250	*5750	*5750	*5750	*4650	*4650	*4650	*3200	*3200	*3200		
1500 mm	Undercarriage: front empty – rear dozer – free on wheels				5600	3800	3450	3700	2550	2350	2750	1900	1750	7420	
	Undercarriage: front empty – rear dozer – stabilized				5550	*6650	3900	3650	*5000	2650	2700	*3450	1950		
	Undercarriage: front dozer – rear stabilizer – stabilized				*6650	*6650	6000	*5000	*5000	3950	*3450	*3450	2950		
	Undercarriage: front stabilizer – rear stabilizer – stabilized				*6650	*6650	*6650	*5000	*5000	4700	*3450	*3450	3450		
0 mm	Undercarriage: front empty – rear dozer – free on wheels	*7300	6450	5700	5350	3650	3300	3600	2500	2250	2800	1950	1800	7200	
	Undercarriage: front empty – rear dozer – stabilized	*7300	*7300	6550	5350	*7000	3700	3550	*5100	2550	2800	*4000	2000		
	Undercarriage: front dozer – rear stabilizer – stabilized	*7300	*7300	*7300	*7000	*7000	5800	*5100	*5100	3850	*4000	*4000	3000		
	Undercarriage: front stabilizer – rear stabilizer – stabilized	*7300	*7300	*7300	*7000	*7000	*7000	*5100	*5100	4600	*4000	*4000	3550		
-1500 mm	Undercarriage: front empty – rear dozer – free on wheels	*9550	6400	5650	5300	3550	3200	3550	2450	2250	3100	2150	1950	6630	
	Undercarriage: front empty – rear dozer – stabilized	*9550	*9550	6500	5250	*6550	3600	3500	*4700	2500	3100	*4050	2200		
	Undercarriage: front dozer – rear stabilizer – stabilized	*9550	*9550	*9550	*6550	*6550	5700	*4700	*4700	3800	*4050	*4050	3300		
	Undercarriage: front stabilizer – rear stabilizer – stabilized	*9550	*9550	*9550	*6550	*6550	*6550	*4700	*4700	4550	*4050	*4050	3950		
-3000 mm	Undercarriage: front empty – rear dozer – free on wheels	*7200	6500	5700	*5150	3550	3250				*3800	2700	2450	5600	
	Undercarriage: front empty – rear dozer – stabilized	*7200	*7200	6550	*5150	*5150	3650				*3800	*3800	2750		
	Undercarriage: front dozer – rear stabilizer – stabilized	*7200	*7200	*7200	*5150	*5150	*5150				*3800	*3800	*3800		
	Undercarriage: front stabilizer – rear stabilizer – stabilized	*7200	*7200	*7200	*5150	*5150	*5150				*3800	*3800	*3800		

*Limited by hydraulic rather than tipping load.

Oscillating axle needs to be locked. Weight of all lifting accessories must be subtracted from the lifting capacities. All lift capacities calculated and rated per ISO 10567:2007. Rated loads do not exceed 87% of hydraulic lift capacity or 75% of tipping load. Heavy Lift Function ON. Lifting capacities are based on the machine standing on a firm uniform supporting surface. The load point is the center line of the bucket pivot mounting pin on the stick. The use of a work tool attachment point to handle/lift objects, could affect the machine lift performance.

Always refer to the appropriate Operation and Maintenance Manual for specific product information.

M314 Wheeled Excavator Specifications

Lift Capacities – One-Piece Boom (15'3"), 9'6" Industrial Stick

All values are in lb, work tool: none, bucket cylinder and bucket linkage installed, counterweight: 7,280 lb, heavy lift function on.

		Load at maximum reach (sticknose/bucket pin)			Load over front			Load over rear			Load over side			Load point height	
	Undercarriage configuration	10 ft			15 ft			20 ft						ft	
20 ft	Undercarriage: front empty – rear dozer – free on wheels										*7,000	6,300	5,800	19.42	
	Undercarriage: front empty – rear dozer – stabilized										*7,000	*7,000	6,400		
	Undercarriage: front dozer – rear stabilizer – stabilized										*7,000	*7,000	*7,000		
	Undercarriage: front stabilizer – rear stabilizer – stabilized										*7,000	*7,000	*7,000		
15 ft	Undercarriage: front empty – rear dozer – free on wheels						8,400	6,000	5,500	*6,800	5,000	4,600	22.41		
	Undercarriage: front empty – rear dozer – stabilized						8,400	*9,300	6,100	*6,800	*6,800	5,100			
	Undercarriage: front dozer – rear stabilizer – stabilized						*9,300	*9,300	9,000	*6,800	*6,800	*6,800			
	Undercarriage: front stabilizer – rear stabilizer – stabilized						*9,300	*9,300	*9,300	*6,800	*6,800	*6,800			
10 ft	Undercarriage: front empty – rear dozer – free on wheels	*17,700	16,300	14,500	*12,400	8,800	8,000	8,200	5,800	5,300	6,300	4,400	4,100	23.95	
	Undercarriage: front empty – rear dozer – stabilized	*17,700	*17,700	16,500	*12,400	*12,400	8,900	8,200	*10,100	5,900	6,300	*7,000	4,500		
	Undercarriage: front dozer – rear stabilizer – stabilized	*17,700	*17,700	*17,700	*12,400	*12,400	*12,400	*10,100	*10,100	8,800	*7,000	*7,000	6,700		
	Undercarriage: front stabilizer – rear stabilizer – stabilized	*17,700	*17,700	*17,700	*12,400	*12,400	*12,400	*10,100	*10,100	*10,100	*7,000	*7,000	*7,000		
5 ft	Undercarriage: front empty – rear dozer – free on wheels				12,000	8,200	7,500	7,900	5,600	5,100	6,000	4,200	3,900	24.34	
	Undercarriage: front empty – rear dozer – stabilized				12,000	*14,400	8,400	7,900	*10,900	5,700	6,000	*7,600	4,300		
	Undercarriage: front dozer – rear stabilizer – stabilized				*14,400	*14,400	13,000	*10,900	*10,900	8,500	*7,600	*7,600	6,500		
	Undercarriage: front stabilizer – rear stabilizer – stabilized				*14,400	*14,400	*14,400	*10,900	*10,900	10,200	*7,600	*7,600	*7,600		
0 ft	Undercarriage: front empty – rear dozer – free on wheels	*16,700	13,900	12,300	11,600	7,800	7,100	7,700	5,400	4,900	6,200	4,300	4,000	23.62	
	Undercarriage: front empty – rear dozer – stabilized	*16,700	*16,700	14,100	11,500	*15,200	8,000	7,700	*11,100	5,500	6,100	*8,900	4,400		
	Undercarriage: front dozer – rear stabilizer – stabilized	*16,700	*16,700	*16,700	*15,200	*15,200	12,500	*11,100	*11,100	8,300	*8,900	*8,900	6,600		
	Undercarriage: front stabilizer – rear stabilizer – stabilized	*16,700	*16,700	*16,700	*15,200	*15,200	*15,200	*11,100	*11,100	9,900	*8,900	*8,900	7,900		
-5 ft	Undercarriage: front empty – rear dozer – free on wheels	*20,700	13,800	12,200	11,400	7,600	6,900	7,600	5,300	4,800	6,800	4,700	4,300	21.72	
	Undercarriage: front empty – rear dozer – stabilized	*20,700	*20,700	14,000	11,300	*14,200	7,800	7,600	*10,200	5,400	6,800	*8,900	4,800		
	Undercarriage: front dozer – rear stabilizer – stabilized	*20,700	*20,700	*20,700	*14,200	*14,200	12,300	*10,200	*10,200	8,200	*8,900	*8,900	7,300		
	Undercarriage: front stabilizer – rear stabilizer – stabilized	*20,700	*20,700	*20,700	*14,200	*14,200	*14,200	*10,200	*10,200	9,800	*8,900	*8,900	8,800		
-10 ft	Undercarriage: front empty – rear dozer – free on wheels	*15,500	13,900	12,300	*11,000	7,700	7,000				*8,300	6,000	5,500	18.24	
	Undercarriage: front empty – rear dozer – stabilized	*15,500	*15,500	14,100	*11,000	*11,000	7,800				*8,300	*8,300	6,100		
	Undercarriage: front dozer – rear stabilizer – stabilized	*15,500	*15,500	*15,500	*11,000	*11,000	*11,000				*8,300	*8,300	*8,300		
	Undercarriage: front stabilizer – rear stabilizer – stabilized	*15,500	*15,500	*15,500	*11,000	*11,000	*11,000				*8,300	*8,300	*8,300		

*Limited by hydraulic rather than tipping load.

Oscillating axle needs to be locked. Weight of all lifting accessories must be subtracted from the lifting capacities. All lift capacities calculated and rated per ISO 10567:2007. Rated loads do not exceed 87% of hydraulic lift capacity or 75% of tipping load. Heavy Lift Function ON. Lifting capacities are based on the machine standing on a firm uniform supporting surface. The load point is the center line of the bucket pivot mounting pin on the stick. The use of a work tool attachment point to handle/lift objects, could affect the machine lift performance.

Always refer to the appropriate Operation and Maintenance Manual for specific product information.

M314 Wheeled Excavator Specifications

Lift Capacities – One-Piece Boom (4400 mm), 2200 mm Stick

All values are in kg, work tool: none, bucket cylinder and bucket linkage installed, counterweight: 3300 kg, heavy lift function on.

		Load at maximum reach (sticknose/bucket pin)			Load over front			Load over rear			Load over side			Load point height	
Stick height	Undercarriage configuration	3000 mm			4500 mm			6000 mm			mm			mm	
		Front	Side	Rear	Front	Side	Rear	Front	Side	Rear	Front	Side	Rear		
6000 mm	Undercarriage: front empty – rear dozer – free on wheels Undercarriage: front bucket rest – rear dozer – stabilized				*4400	4200	3750				*3000	*3000	*3000	5090	
4500 mm	Undercarriage: front empty – rear dozer – free on wheels Undercarriage: front bucket rest – rear dozer – stabilized				*5250	4150	3700	*3250	2600	2300	*2800	2550	2250	6090	
3000 mm	Undercarriage: front empty – rear dozer – free on wheels Undercarriage: front bucket rest – rear dozer – stabilized	*9000	7300	6350	*6000	3900	3450	4500	2550	2250	*2850	2200	1950	6590	
1500 mm	Undercarriage: front empty – rear dozer – free on wheels Undercarriage: front bucket rest – rear dozer – stabilized	*5750	*5750	5650	*6700	3650	3250	4400	2450	2150	*3050	2050	1850	6710	
0 mm	Undercarriage: front empty – rear dozer – free on wheels Undercarriage: front bucket rest – rear dozer – stabilized	*7200	6400	5500	*6700	3500	3100	4350	2350	2100	*3500	2150	1900	6470	
-1500 mm	Undercarriage: front empty – rear dozer – free on wheels Undercarriage: front bucket rest – rear dozer – stabilized	*8200	6450	5500	*5800	3500	3050				*3900	2450	2150	5830	
-3000 mm	Undercarriage: front empty – rear dozer – free on wheels Undercarriage: front bucket rest – rear dozer – stabilized	*5000	*5000	*5000	*3250	*3250	3150				*3050	*3050	*3050	4600	

*Limited by hydraulic rather than tipping load.

Oscillating axle needs to be locked. Weight of all lifting accessories must be subtracted from the lifting capacities. All lift capacities calculated and rated per ISO 10567:2007. Rated loads do not exceed 87% of hydraulic lift capacity or 75% of tipping load. Heavy Lift Function ON. Lifting capacities are based on the machine standing on a firm uniform supporting surface. The load point is the center line of the bucket pivot mounting pin on the stick. The use of a work tool attachment point to handle/lift objects, could affect the machine lift performance.

Always refer to the appropriate Operation and Maintenance Manual for specific product information.

Lift Capacities – One-Piece Boom (14'5"), 7'3" Stick

All values are in lb, work tool: none, bucket cylinder and bucket linkage installed, counterweight: 7,280 lb, heavy lift function on.

		Load at maximum reach (sticknose/bucket pin)			Load over front			Load over rear			Load over side			Load point height	
Stick height	Undercarriage configuration	10 ft			15 ft			20 ft			ft			ft	
		Front	Side	Rear	Front	Side	Rear	Front	Side	Rear	Front	Side	Rear		
20 ft	Undercarriage: front empty – rear dozer – free on wheels Undercarriage: front bucket rest – rear dozer – stabilized				*9,300	9,000	8,100				*6,700	*6,700	*6,700	16.40	
15 ft	Undercarriage: front empty – rear dozer – free on wheels Undercarriage: front bucket rest – rear dozer – stabilized				*11,400	8,900	7,900				*6,200	5,600	5,000	19.85	
10 ft	Undercarriage: front empty – rear dozer – free on wheels Undercarriage: front bucket rest – rear dozer – stabilized	*19,300	15,800	13,700	*13,000	8,500	7,500	9,700	5,500	4,900	*6,200	4,800	4,300	21.59	
5 ft	Undercarriage: front empty – rear dozer – free on wheels Undercarriage: front bucket rest – rear dozer – stabilized	*14,000	*14,000	12,200	*14,500	7,900	7,000	9,500	5,300	4,700	*6,700	4,600	4,000	22.01	
0 ft	Undercarriage: front empty – rear dozer – free on wheels Undercarriage: front bucket rest – rear dozer – stabilized	*16,600	13,800	11,800	*14,500	7,600	6,700	9,300	5,100	4,500	*7,800	4,700	4,200	21.23	
-5 ft	Undercarriage: front empty – rear dozer – free on wheels Undercarriage: front bucket rest – rear dozer – stabilized	*17,800	13,800	11,800	*12,500	7,500	6,600				*8,600	5,400	4,800	19.09	
-10 ft	Undercarriage: front empty – rear dozer – free on wheels Undercarriage: front bucket rest – rear dozer – stabilized	*10,600	*10,600	*10,600							*6,600	*6,600	*6,600	14.93	

*Limited by hydraulic rather than tipping load.

Oscillating axle needs to be locked. Weight of all lifting accessories must be subtracted from the lifting capacities. All lift capacities calculated and rated per ISO 10567:2007. Rated loads do not exceed 87% of hydraulic lift capacity or 75% of tipping load. Heavy Lift Function ON. Lifting capacities are based on the machine standing on a firm uniform supporting surface. The load point is the center line of the bucket pivot mounting pin on the stick. The use of a work tool attachment point to handle/lift objects, could affect the machine lift performance.

Always refer to the appropriate Operation and Maintenance Manual for specific product information.

M314 Wheeled Excavator Specifications

Lift Capacities – One-Piece Boom (4400 mm), 2500 mm Stick

All values are in kg, work tool: none, bucket cylinder and bucket linkage installed, counterweight: 3300 kg, heavy lift function on.

		Load at maximum reach (sticknose/bucket pin)			Load over front			Load over rear			Load over side			Load point height		
	Undercarriage configuration	3000 mm			4500 mm			6000 mm						mm		
6000 mm	Undercarriage: front empty – rear dozer – free on wheels Undercarriage: front bucket rest – rear dozer – stabilized				*4050	*4050	3850				*2600	*2600	*2600	5450		
4500 mm	Undercarriage: front empty – rear dozer – free on wheels Undercarriage: front bucket rest – rear dozer – stabilized				*4650	4200	3750	*3600	2650	2350	*2450	2350	2100	6400		
3000 mm	Undercarriage: front empty – rear dozer – free on wheels Undercarriage: front bucket rest – rear dozer – stabilized	*8450	7500	6500	*5800	4000	3550	4550	2550	2300	*2450	2050	1850	6870		
1500 mm	Undercarriage: front empty – rear dozer – free on wheels Undercarriage: front bucket rest – rear dozer – stabilized	*7650	6750	5800	*6600	3750	3300	4450	2450	2200	*2600	1950	1750	6990		
0 mm	Undercarriage: front empty – rear dozer – free on wheels Undercarriage: front bucket rest – rear dozer – stabilized	*7400	6450	5550	*6800	3550	3100	4350	2400	2100	*3000	2000	1800	6760		
-1500 mm	Undercarriage: front empty – rear dozer – free on wheels Undercarriage: front bucket rest – rear dozer – stabilized	*8850	6450	5500	*6050	3500	3050	*4100	2350	2100	*3800	2300	2050	6150		
-3000 mm	Undercarriage: front empty – rear dozer – free on wheels Undercarriage: front bucket rest – rear dozer – stabilized	*5900	*5900	5650	*4050	3550	3150				*3250	3100	2700	5010		

*Limited by hydraulic rather than tipping load.

Oscillating axle needs to be locked. Weight of all lifting accessories must be subtracted from the lifting capacities. All lift capacities calculated and rated per ISO 10567:2007. Rated loads do not exceed 87% of hydraulic lift capacity or 75% of tipping load. Heavy Lift Function ON. Lifting capacities are based on the machine standing on a firm uniform supporting surface. The load point is the center line of the bucket pivot mounting pin on the stick. The use of a work tool attachment point to handle/lift objects, could affect the machine lift performance.

Always refer to the appropriate Operation and Maintenance Manual for specific product information.

Lift Capacities – One-Piece Boom (14'5"), 8'2" Stick

All values are in lb, work tool: none, bucket cylinder and bucket linkage installed, counterweight: 7,280 lb, heavy lift function on.

		Load at maximum reach (sticknose/bucket pin)			Load over front			Load over rear			Load over side			Load point height		
	Undercarriage configuration	10 ft			15 ft			20 ft						ft		
20 ft	Undercarriage: front empty – rear dozer – free on wheels Undercarriage: front bucket rest – rear dozer – stabilized				*8,800	*8,800	8,200				*5,800	*5,800	*5,800	17.62		
15 ft	Undercarriage: front empty – rear dozer – free on wheels Undercarriage: front bucket rest – rear dozer – stabilized				*10,100	9,100	8,100	*7,400	5,700	5,100	*5,400	5,300	4,700	20.87		
10 ft	Undercarriage: front empty – rear dozer – free on wheels Undercarriage: front bucket rest – rear dozer – stabilized	*18,100	16,200	14,100	*12,500	8,600	7,600	9,800	5,500	4,900	*5,400	4,600	4,100	22.51		
5 ft	Undercarriage: front empty – rear dozer – free on wheels Undercarriage: front bucket rest – rear dozer – stabilized	*18,600	14,500	12,500	*14,300	8,000	7,100	9,600	5,300	4,700	*5,800	4,300	3,900	22.93		
0 ft	Undercarriage: front empty – rear dozer – free on wheels Undercarriage: front bucket rest – rear dozer – stabilized	*17,100	13,900	11,900	*14,600	7,700	6,700	9,400	5,100	4,600	*6,600	4,500	3,900	22.18		
-5 ft	Undercarriage: front empty – rear dozer – free on wheels Undercarriage: front bucket rest – rear dozer – stabilized	*19,100	13,800	11,900	*13,100	7,500	6,600	*8,600	5,100	4,500	*8,400	5,100	4,500	20.14		
-10 ft	Undercarriage: front empty – rear dozer – free on wheels Undercarriage: front bucket rest – rear dozer – stabilized	*12,600	*12,600	12,100	*8,500	7,700	6,800				*7,000	6,900	6,100	16.27		

*Limited by hydraulic rather than tipping load.

Oscillating axle needs to be locked. Weight of all lifting accessories must be subtracted from the lifting capacities. All lift capacities calculated and rated per ISO 10567:2007. Rated loads do not exceed 87% of hydraulic lift capacity or 75% of tipping load. Heavy Lift Function ON. Lifting capacities are based on the machine standing on a firm uniform supporting surface. The load point is the center line of the bucket pivot mounting pin on the stick. The use of a work tool attachment point to handle/lift objects, could affect the machine lift performance.

Always refer to the appropriate Operation and Maintenance Manual for specific product information.

Standard and Optional Equipment

Standard and optional equipment may vary. Consult your Cat dealer for details.

	Standard	Optional		Standard	Optional
BOOM, STICKS AND LINKAGES			HYDRAULIC SYSTEM		
4650 mm (15'3") One-Piece Boom ⁽⁴⁾		✓	Boom, stick and bucket drift reduction valves	✓	
4400 mm (14'5") One-Piece Boom ⁽¹⁾		✓	Boom/stick lowering check valves		✓
5028 mm (16'6") Variable Adjustable boom		✓	Overload warning	✓	
2200 mm (7'3") stick		✓	Electronic main control valve	✓	
2500 mm (8'2") stick		✓	Automatic hydraulic oil warm up	✓	
2900 mm (9'6") Drop Nose stick without bucket linkage ⁽²⁾		✓	Element type main hydraulic filter	✓	
Bucket linkage, 312-family with lifting eye		✓	One-slider joysticks		✓
Bucket linkage, 312-family without lifting eye ⁽²⁾		✓	Two-slider joysticks		✓
ELECTRICAL SYSTEM			Advanced Tool Control (one/two way high-pressure flow)		✓
LED lights on boom and cab	✓		Second high pressure auxiliary circuit (one/two way high-pressure flow)		✓
LED lights on chassis (left-hand, right-hand) and counterweight		✓	Medium pressure auxiliary circuit (one/two way medium-pressure flow)		✓
Programmable time-delay LED working lights	✓		Heavy lift mode	✓	
Roading and indicator lights, front and rear	✓		Quick coupler circuit for Cat Pin Grabber and CW-type coupler		✓
Maintenance free batteries	✓		SmartBoom™		✓
Centralized electrical disconnect switch	✓		Ride control		✓
Electrical refueling pump		✓	Cat TRS support		✓
ENGINE			Joystick steering		✓
Cat C3.6 Single Turbo diesel engine (meets Tier 4 Final/Stage V emission standards)	✓		Separate dedicated swing pump	✓	
Power mode selector	✓		Automatic swing brake	✓	
One-touch low idle with automatic engine speed control	✓		Cat BIO HYDO™ Advanced biodegradable hydraulic oil		✓
Automatic engine idle shutdown	✓		Adjustable hydraulic aggressiveness	✓	
52° C (125° F) high-ambient cooling capacity	✓		Electronic pattern changer	✓	
Cold starting capability for -18° C (0° F)	✓				
Double element air filter with integrated pre-cleaner	✓				
Electric fuel priming pump	✓				
Engine driven fan with fluid temperature controlled variable fan speed	✓				
Biodiesel capability up to B20	✓				

⁽¹⁾Available in South Korea only.

⁽²⁾Available in Europe only.

⁽⁴⁾Available in Europe, Australia and New Zealand only.

M314 Standard and Optional Equipment

Standard and Optional Equipment (continued)

Standard and optional equipment may vary. Consult your Cat dealer for details.

	Standard	Optional		Standard	Optional
SAFETY AND SECURITY			UNDERCARRIAGE AND STRUCTURES		
Rear and right-side-view cameras	✓		All wheel drive	✓	
360° visibility		✓	Automatic brake/axle lock	✓	
Wide angle mirrors	✓		Creeper speed	✓	
Travel alarm		✓	Electronic swing and travel lock	✓	
Signal/warning horn	✓		Heavy-duty axles, advanced disc brake system and travel motor, adjustable braking force	✓	
Rotating beacon on cab and chassis		✓	Oscillating front axle, lockable, with remote greasing point	✓	
Cat Asset tracker		✓	9.00-20.16 PR, dual tires ⁽¹⁾		✓
Neutral lever (lock out) for all controls	✓		10.00-20 16 PR, dual tires		✓
Ground-level accessible secondary engine shutoff switch in cab	✓		10.00-20, dual, solid rubber tires		✓
Lockable disconnect switch	✓		300-80-22.5 dual pneumatic, spacerless tire ⁽²⁾		✓
Bluetooth® receiver	✓		Steps with tool box in undercarriage (left and right)	✓	
Anti-skid plate and countersunk bolts on service platform	✓		Two-piece drive shaft	✓	
Inspection lighting		✓	Two speed hydrostatic transmission	✓	
2D E-Fence		✓	Rear blade (radial) undercarriage ⁽²⁾		✓
SERVICE AND MAINTENANCE			Rear blade (radial) with bucket rest undercarriage ⁽¹⁾		✓
Scheduled Oil Sampling (S·O·S SM) ports	✓		Rear blade (radial)/front outrigger undercarriage		✓
Automatic lubrication system for implement and swing system		✓	Undercarriage steps and plastic type fenders for front and rear tires for 2.55 m (8'4") wheel base undercarriage		✓
Integrated vehicle health management system	✓		Undercarriage steps for 2.55 m (8'4") wheel base undercarriage		✓
TECHNOLOGY			Rear outrigger/front blade (radial) undercarriage		✓
VisionLink®	✓*		Rear outrigger/front outrigger undercarriage ⁽³⁾		✓
Remote Flash	✓		Fenders, front and rear, synthetic ⁽³⁾		✓
Remote Troubleshoot	✓		Fenders, front and rear, steel ⁽¹⁾		✓
Cat Grade Connectivity		✓	Travel restraint bracket for grapple/clamshell ⁽²⁾		✓
Cat Grade 2D		✓	3300 kg (7275 lb) counterweight	✓	
Cat Grade 2D with Attachment Ready Option (ARO)		✓			
Cat Grade 3D dual GNSS		✓			
Laser catcher		✓			
Cat Assist: – Grade Assist		✓			
Cat Payload: – Static weigh – Semiautomatic calibration – Payload/cycle information – USB reporting capability		✓			
Cat Tilt Rotator (TRS) Integration		✓			

*Connect subscription only. Additional subscriptions are available. Contact your Cat dealer for availability.

⁽¹⁾Available in South Korea only.

⁽²⁾Available in Europe only.

⁽³⁾Not available in South Korea.

⁽⁴⁾Available in Europe, Australia and New Zealand only.

Dealer Installed Kits and Attachments

Attachments may vary. Consult your Cat dealer for details.

CAB

- 75 mm (3") retractable seat belt

SAFETY AND SECURITY

- Bluetooth® key fob

GUARDS

- Operator Protective Guard (not compatible with cab light cover, rain protector)
- Mesh guard full front (not compatible with cab light cover, rain protector)

M314 Cab Options

	Deluxe	Premium
Cab structure meeting ISO 12117-2 ROPS (Rollover Protective Structure) standard	●	●
Heated seat with adjustable air suspension	●	X
Heated and cooled seat with semi-automatic adjustable air suspension	X	●
Height-adjustable console, infinite with no tool	●	●
High-resolution 254 mm (10") LCD touchscreen monitor	●	●
Mechanical mirror	●	X
Electrical adjustable and heatable mirror	X	●
Automatic bi-level air conditioner	●	●
Jog dial and shortcut keys for monitor control	●	●
Keyless push-to-start engine control	●	●
51 mm (2") orange seat belt	●	●
Unfastened seat belt warning	●	●
Bluetooth integrated radio (including USB, auxiliary port and microphone)	●	●
Auxiliary relay	○	○
2 × 12V DC outlets	●	●
Document storage	●	●
Cup and bottle holders	●	●
Openable two-piece front window (laminated)	●	○
Fixed one-piece front window (P5A classified)	X	○
Parallel wiper with washer	●	●
Fixed glass skylight	●	●
LED dome lights	●	●
Foot illumination	●	●
Roller rear sunscreen	X	●
Rear window emergency exit	●	●
Washable floor mat	●	●
Beacon ready	●	●
OPG "ready"	●	●
Vandal guards "ready"	●	●
Two LED cab lights	●	●
Rain visor	●	●

- Standard
- Optional
- X Not available

The following information applies to the machine at the time of final manufacture as configured for sale in the regions covered in this document. The content of this declaration is valid as of the date issued; however, content related to machine features and specifications are subject to change without notice. For additional information, please see the machine's Operation and Maintenance Manual.

For more information on sustainability in action and our progress, please visit <https://www.caterpillar.com/en/company/sustainability>.

Engine

- The Cat® C3.6 engine meets U.S. EPA Tier 4 Final, EU Stage V, and Korea Tier 5 emission standards.
- Cat diesel engines are required to use ULSD (ultra-low sulfur diesel fuel with 15 ppm of sulfur or less) or ULSD blended with the following lower-carbon intensity fuels** up to:
 - ✓ 20% biodiesel FAME (fatty acid methyl ester)*
 - ✓ 100% renewable diesel, HVO (hydrotreated vegetable oil) and GTL (gas-to-liquid) fuels

Refer to guidelines for successful application. Please consult your Cat dealer or “Caterpillar Machine Fluids Recommendations” (SEBU6250) for details.

**Engines with no aftertreatment devices can use higher blends, up to 100% biodiesel (for use of blends higher than 20% biodiesel, consult your Cat dealer).*

***Tailpipe greenhouse gas emissions from lower-carbon intensity fuels are essentially the same as traditional fuels.*

Air Conditioning System

- The air conditioning system on this machine contains the fluorinated greenhouse gas refrigerant R134a (Global Warming Potential = 1430). The system contains 0.8 kg (1.8 lb) of refrigerant which has a CO₂ equivalent of 1.144 metric tonnes (1.261 tons).

Paint

- Based on best available knowledge, the maximum allowable concentration, measured in parts per million (PPM), of the following heavy metals in paint are:
 - Barium < 0.01%
 - Cadmium < 0.01%
 - Chromium < 0.01%
 - Lead < 0.01%

Sound Performance

ISO 6396:2008 internal – 70 dB(A)

ISO 6395:2008 external – 100 dB(A)

- External Sound – The labelled spectator sound power level represents the Guaranteed Value per 2000/14/EC amended by 2005/88/EC, when properly equipped, and is measured according to the test procedures and conditions specified in ISO 6395:2008. The measurements were conducted at 70% of the maximum engine cooling fan speed.
- Internal Sound – The operator sound pressure level is measured according to the test procedures and conditions specified in ISO 6396:2008 for a cab offered by Caterpillar, when properly installed and maintained and tested with the door and windows closed. The measurements were conducted at 70% of the maximum engine cooling fan speed.
- Blue Angel certified.

Oils and Fluids

- Caterpillar factory fills with ethylene glycol coolants. Cat Diesel Engine Antifreeze/Coolant (DEAC) and Cat Extended Life Coolant (ELC) can be recycled. Consult your Cat dealer for more information.
- Cat Bio HYDO Advanced is an EU Ecolabel approved biodegradable hydraulic oil.
- Additional fluids are likely to be present, please consult the Operations and Maintenance Manual or the Application and Installation guide for complete fluid recommendations and maintenance intervals.

Features and Technology

- The following features and technology may contribute to fuel savings and/or carbon reduction. Features may vary. Consult your Cat dealer for details.
 - Advanced hydraulic systems balance power and efficiency
 - The latest hydraulic oil filter provides longer life with a 3,000-hour replacement interval – 50% longer than previous filter designs
 - Eco mode minimizes fuel consumption for light applications
 - One-touch low idle with automatic engine speed control
 - Optional Cat Grade with 2D improves operator efficiency by up to 45%
 - Optional Cat Payload on-board weighing system increases loading efficiency
 - Remote Flash and Remote Troubleshoot

Recycling

- The materials included in machines are categorized as below with approximate weight percentage. Because of variations of product configurations, the following values in the table may vary.

Material Type	Weight Percentage
Steel	75.40%
Iron	8.62%
Nonferrous Metal	3.19%
Mixed Metal	0.71%
Mixed-Metal and Nonmetal	1.36%
Plastic	1.57%
Rubber	1.47%
Mixed Nonmetallic	0.02%
Fluid	2.35%
Other	0.30%
Uncategorized	5.01%
Total	100%

- A machine with higher recyclability rate will ensure more efficient usage of valuable natural resources and enhance End-of-Life value of the product. According to ISO 16714:2008 (Earthmoving machinery – Recyclability and recoverability – Terminology and calculation method), recyclability rate is defined as percentage by mass (mass fraction in percent) of the new machine potentially able to be recycled, reused, or both.

All parts in the bill of material are first evaluated by component type based on a list of components defined by the ISO 16714:2008 and Japan CEMA (Construction Equipment Manufacturers Association) standards. Remaining parts are further evaluated for recyclability based on material type.

Because of variations of product configurations, the following value in the table may vary.

Recyclability – 91%

For more complete information on Cat products, dealer services, and industry solutions, visit us on the web at www.cat.com

© 2024 Caterpillar
All rights reserved

Materials and specifications are subject to change without notice. Featured machines in photos may include additional equipment. See your Cat dealer for available options.

CAT, CATERPILLAR, LET'S DO THE WORK, their respective logos, "Caterpillar Corporate Yellow," the "Power Edge" and Cat "Modern Hex" trade dress as well as corporate and product identity used herein, are trademarks of Caterpillar and may not be used without permission. VisionLink is a trademark of Caterpillar Inc., registered in the United States and in other countries.

AEXQ2743-07 (03-2024)
Replaces AEXQ2743-06
Build Number: 07D
(N Am, Eur, Aus-NZ, S Korea)

