



Cat® Contractors' Grapples

G100 Series

Technical Specifications

Not all grapple models are available in all regions. Consult your Cat® dealer for models available in your region.

Table of Contents

| | |
|-------------------------------------|---|
| Specifications and Dimensions | 2 |
| Matching | 3 |

Contractors' Grapples Technical Specifications

Specifications and Dimensions

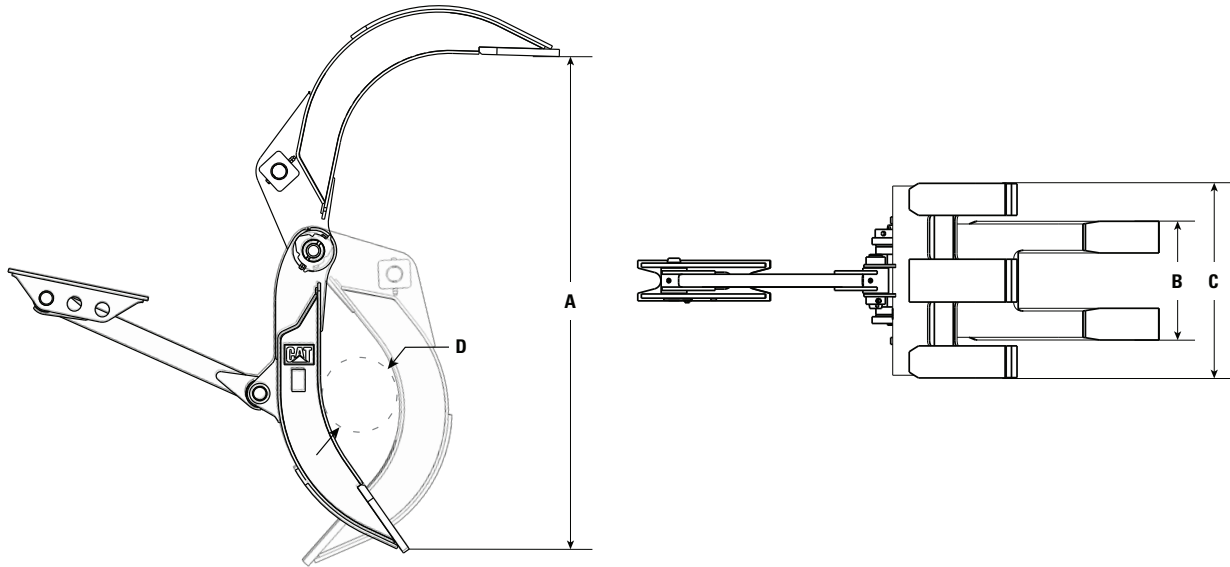

| Grapple Model | Part Number | Linkage | Weight | | (A) Jaw Opening | | (B) Upper Tine Width | | (C) Lower Tine Width | | (D) Minimum Opening | | Inner Wrapper Thickness | | Outer Wrapper Thickness | | Wear Tip Thickness | | Outer Wear Plate Thickness | |
|---------------|-------------|---------|--------|------|-----------------|--------|----------------------|-------|----------------------|-------|---------------------|-------|-------------------------|------|-------------------------|------|--------------------|------|----------------------------|------|
| | | | kg | lb | mm | in | mm | in | mm | in | mm | in | mm | in | mm | in | mm | in | mm | in |
| G113 | 590-1850 | 312 | 857 | 1885 | 2195 | 86.40 | 550 | 21.70 | 900 | 35.40 | 186 | 7.30 | 12 | 0.50 | 12 | 0.50 | 20 | 0.80 | 16 | 0.60 |
| G117 | 590-1855 | 315 | 1286 | 2830 | 2555 | 100.60 | 610 | 24.00 | 1020 | 40.20 | 191 | 7.50 | 12 | 0.50 | 12 | 0.50 | 25 | 1.00 | 25 | 1.00 |
| G120 | 590-1856 | B | 1523 | 3350 | 2687 | 105.80 | 617 | 24.00 | 1031 | 40.60 | 199 | 7.80 | 16 | 0.60 | 12 | 0.50 | 30 | 1.20 | 20 | 0.80 |
| G126 | 590-1859 | B | 1932 | 4250 | 3128 | 123.10 | 704 | 27.70 | 1150 | 45.30 | 246 | 9.60 | 16 | 0.60 | 16 | 0.60 | 40 | 1.60 | 20 | 0.80 |
| G120 | 590-1858 | CB | 1523 | 3350 | 2687 | 105.80 | 617 | 24.00 | 1031 | 40.60 | 199 | 7.80 | 16 | 0.60 | 12 | 0.50 | 30 | 1.20 | 20 | 0.80 |
| G126 | 590-1862 | CB | 1932 | 4250 | 3128 | 123.10 | 704 | 27.70 | 1150 | 45.30 | 246 | 9.60 | 16 | 0.60 | 16 | 0.60 | 40 | 1.60 | 20 | 0.80 |
| G136 | 590-1864 | CB | 2332 | 5130 | 3223 | 126.90 | 832 | 32.80 | 1262 | 49.70 | 319 | 12.60 | 20 | 0.80 | 20 | 0.80 | 40 | 1.60 | 20 | 0.80 |
| G136 | 590-1867 | DB | 2332 | 5130 | 3223 | 126.90 | 832 | 32.80 | 1262 | 49.70 | 319 | 12.60 | 20 | 0.80 | 20 | 0.80 | 40 | 1.60 | 20 | 0.80 |
| G149 | 590-1869 | TB | 3050 | 6724 | 3433 | 135.20 | 865 | 34.10 | 1335 | 52.60 | 271 | 10.70 | 20 | 0.80 | 20 | 0.80 | 40 | 1.60 | 25 | 1.00 |
| G174 | 590-1871 | VB | 4055 | 8940 | 3860 | 152.00 | 937 | 36.90 | 1406 | 55.40 | 283 | 11.10 | 25 | 1.00 | 25 | 1.00 | 40 | 1.60 | 30 | 1.20 |

Contractors' Grapples Technical Specifications

Matching

Match No match

| Grapple Model | G113 | G117 | G120 | G126 | G120 | G126 | G136 | G136 | G149 | G174 |
|---------------|----------|----------|----------|----------|----------|----------|----------|----------|----------|----------|
| Part Number | 590-1850 | 590-1855 | 590-1856 | 590-1859 | 590-1858 | 590-1862 | 590-1864 | 590-1867 | 590-1869 | 590-1871 |
| Linkage | 312 | 315 | B | B | CB | CB | CB | DB | TB | VB/VB2 |

Small Excavators

| | | | | | | | | | | |
|-----------------|---|---|---|---|--|--|--|--|--|--|
| 311D/F | ✓ | | | | | | | | | |
| 312D/E | ✓ | | | | | | | | | |
| 312D2/D2 GC | ✓ | | | | | | | | | |
| 313D2/D2 GC | ✓ | | | | | | | | | |
| 312F GC/313F GC | ✓ | | | | | | | | | |
| 312F/313F | ✓ | | | | | | | | | |
| 313/313 GC | ✓ | | | | | | | | | |
| 314D/E/F | ✓ | | | | | | | | | |
| 315F | ✓ | | | | | | | | | |
| 315 | ✓ | | | | | | | | | |
| 315D/316E/F | | ✓ | | | | | | | | |
| 318E/F | | ✓ | | | | | | | | |
| 318D2 | | ✓ | | | | | | | | |
| 319D | | | ✓ | ✓ | | | | | | |

Medium Excavators

| | | | | | | | | | | |
|----------|--|--|---|---|---|---|---|---|---|--|
| 320D/E/F | | | ✓ | ✓ | | | | | | |
| 320D2/D3 | | | ✓ | ✓ | | | | | | |
| 320 GC | | | ✓ | ✓ | | | | | | |
| 320 | | | ✓ | ✓ | | | | | | |
| 321D | | | ✓ | ✓ | | | | | | |
| 323D/D3 | | | ✓ | ✓ | | | | | | |
| 323E/F | | | ✓ | ✓ | | | | | | |
| 323 | | | ✓ | ✓ | | | | | | |
| 324D/E | | | | | ✓ | ✓ | ✓ | ✓ | | |
| 325D/F | | | | | ✓ | ✓ | ✓ | ✓ | | |
| 325 | | | | | ✓ | ✓ | ✓ | ✓ | | |
| 326D2/F | | | | | ✓ | ✓ | ✓ | ✓ | | |
| 326 | | | | | ✓ | ✓ | ✓ | ✓ | | |
| 328D | | | | | ✓ | ✓ | ✓ | | | |
| 329D/E/F | | | | | ✓ | ✓ | ✓ | ✓ | | |
| 330D | | | | | | | | ✓ | ✓ | |
| 330D2 | | | | | ✓ | ✓ | ✓ | ✓ | | |
| 330F | | | | | ✓ | ✓ | ✓ | ✓ | | |
| 330 GC | | | | | ✓ | ✓ | ✓ | ✓ | | |
| 330 | | | | | ✓ | ✓ | ✓ | ✓ | | |
| 335F | | | | | ✓ | ✓ | ✓ | | | |

Contractors' Grapples Technical Specifications

Matching

Match No match

| Grapple Model | G113 | G117 | G120 | G126 | G120 | G126 | G136 | G136 | G149 | G174 |
|-------------------------|----------|----------|----------|----------|----------|----------|----------|----------|----------|----------|
| Part Number | 590-1850 | 590-1855 | 590-1856 | 590-1859 | 590-1858 | 590-1862 | 590-1864 | 590-1867 | 590-1869 | 590-1871 |
| Linkage | 312 | 315 | B | B | CB | CB | CB | DB | TB | VB/VB2 |
| Large Excavators | | | | | | | | | | |
| 336D/D2/E | | | | | | | | ✓ | ✓ | |
| 336D2 GC | | | | | | | | ✓ | ✓ | |
| 336D2 XE | | | | | | | | ✓ | ✓ | |
| 336E H | | | | | | | | ✓ | | |
| 336F | | | | | | | | ✓ | ✓ | |
| 336F XE | | | | | | | | ✓ | ✓ | |
| 336 GC | | | | | | | | ✓ | ✓ | |
| 336 | | | | | | | | ✓ | ✓ | |
| 340D2 | | | | | | | | ✓ | ✓ | |
| 340F | | | | | | | | ✓ | ✓ | |
| 340 | | | | | | | | ✓ | ✓ | |
| 345 GC | | | | | | | | | ✓ | |
| 345D/349D | | | | | | | | | ✓ | |
| 349D2 | | | | | | | | | ✓ | |
| 349E/F | | | | | | | | | ✓ | |
| 349 | | | | | | | | | ✓ | |
| 352F | | | | | | | | | ✓ | |
| 352 | | | | | | | | | ✓ | |
| 374F | | | | | | | | | | ✓ |
| 374 | | | | | | | | | | ✓ |

Contractors' Grapples Technical Specifications

Matching

Match No match

| Grapple Model | G113 | G117 | G120 | G126 | G120 | G126 | G136 | G136 | G149 | G174 |
|---------------|----------|----------|----------|----------|----------|----------|----------|----------|----------|----------|
| Part Number | 590-1850 | 590-1855 | 590-1856 | 590-1859 | 590-1858 | 590-1862 | 590-1864 | 590-1867 | 590-1869 | 590-1871 |
| Linkage | 312 | 315 | B | B | CB | CB | CB | DB | TB | VB/VB2 |

Wheeled Excavators

| | | | | | | | | | | |
|--------|--|---|---|---|--|--|--|--|--|--|
| M313D | | ✓ | | | | | | | | |
| M314F | | ✓ | | | | | | | | |
| M314 | | ✓ | | | | | | | | |
| M315D | | ✓ | | | | | | | | |
| M315D2 | | ✓ | | | | | | | | |
| M315F | | ✓ | | | | | | | | |
| M316D | | ✓ | | | | | | | | |
| M316F | | ✓ | | | | | | | | |
| M316 | | ✓ | | | | | | | | |
| M317D2 | | ✓ | | | | | | | | |
| M317F | | ✓ | | | | | | | | |
| M318D | | | ✓ | ✓ | | | | | | |
| M318F | | ✓ | | | | | | | | |
| M318 | | ✓ | | | | | | | | |
| M320D2 | | | ✓ | ✓ | | | | | | |
| M320F | | | ✓ | ✓ | | | | | | |
| M320 | | | ✓ | ✓ | | | | | | |
| M322D | | | ✓ | ✓ | | | | | | |
| M322D2 | | | ✓ | ✓ | | | | | | |
| M322F | | | ✓ | ✓ | | | | | | |

Material Handlers†

| | | | | | | | | | | |
|--------|--|--|---|---|---|---|---|--|--|--|
| MH3022 | | | ✓ | ✓ | | | | | | |
| MH3024 | | | ✓ | ✓ | | | | | | |
| MH3026 | | | ✓ | ✓ | | | | | | |
| MH3040 | | | | | ✓ | ✓ | ✓ | | | |

† When equipped with appropriate stick and bucket linkage

For more complete information on Cat products, dealer services, and industry solutions, visit us on the web at www.cat.com.

© 2020 Caterpillar
All rights reserved

Materials and specifications are subject to change without notice. Featured machines in photos may include additional equipment. See your Cat dealer for available options.

CAT, CATERPILLAR, LET'S DO THE WORK, their respective logos, "Caterpillar Corporate Yellow", the "Power Edge" and Cat "Modern Hex" trade dress as well as corporate and product identity used herein, are trademarks of Caterpillar and may not be used without permission.

GEJQ2382-00 (3-2020)
Replaces GEJQ0195-05
(N Am)

