

Cat® G3512 WITH FAST RESPONSE

Gas Generator Sets



Image shown may not reflect actual configuration

Bore – mm (in)	170 (6.7)
Stroke – mm (in)	190 (7.5)
Displacement – L (in ³)	52 (3173)
Compression Ratio	9.7
Aspiration	Turbocharged
Fuel System	Electronic Fuel Control Valve
Governor Type	ADEM™ A4

Standby and Continuous 60 Hz ekW (kVA) w/Fan	Emissions Performance
1000 (1250)	U.S. EPA Stationary Certified
750 (938)	U.S. EPA Stationary Certified

Standard Features

Cat® Natural Gas Engine

- Meets U.S. EPA Stationary Non-Emergency standards to be used in Emergency and Non-Emergency applications
- Robust high speed block design provides prolonged life and lower owning and operating costs
- Designed for maximum performance on low pressure gaseous fuel supply

Generator Set Package

- Accepts 100% block load in one step and facilitates compliance with NFPA 110, Type 10 starting and loading requirements
- Conforms to ISO 8528-5 G3 load acceptance criteria
- Reliability verified through torsional vibration, fuel consumption, oil consumption, transient performance, and endurance testing

Generators

- Superior motor starting capability minimizes need for oversizing generator
- Designed to match performance and output characteristics of Cat engines

Cooling System

- Cooling systems available to operate in ambient temperatures up to 43°C (110°F)
- Package tested to ensure proper cooling of complete generator set

EMCP 4 Control Panels

- User-friendly interface and navigation
- Scalable system to meet a wide range of installation requirements
- Expansion modules and site specific programming for specific customer requirements

Warranty

- 24 months/1000-hour warranty for standby ratings
- 12 months/unlimited hour warranty for continuous ratings
- Extended service protection is available to provide extended coverage options

Worldwide Product Support

- Cat dealers have over 1,800 dealer branch stores operating in 200 countries
- Your local Cat dealer provides extensive post-sale support, including maintenance and repair agreements

Financing

- Caterpillar offers an array of financial products to help you succeed through financial service excellence
- Options include loans, finance lease, operating lease, working capital, and revolving line of credit
- Contact your local Cat dealer for availability in your region

Optional Equipment

Engine

Air Cleaner (Single Element)

- Installed
- Supplied loose

Muffler

- Industrial grade (15 dB)
- Residential grade (18 dB)
- Critical grade (25 dB)
- Spark arresting

Starting

- Standard batteries
- Standard electric starter(s)
- Air starter(s)
- Jacket water heater

Generators

Output voltage

- 208V 2400V
- 220V 4160V
- 240V 12470V
- 380V 13200V
- 440V 13800V
- 480V
- 600V

Temperature Rise (over 40°C ambient)

- 150°C
- 125°C/130°C
- 105°C
- 80°C

Winding type

- Random wound
- Form wound

Excitation

- Permanent magnet (PM)

Attachments

- Anti-condensation heater
- Stator and bearing temperature monitoring and protection

Power Termination

Type

- Bus bar
- Circuit breaker
- 400A 800A
- 1200A 1600A
- 2000A 2500A
- 3200A 4000A
- UL IEC
- 3-pole 4-pole
- Manually operated

- Electrically operated

Trip Unit

- LSI
- LSI-G
- LSI-G-P

Enclosure

- Weather protective
- Sound attenuated

Attachments

- Cold weather bundle
- DC lighting package
- AC lighting package
- Motorized louvers

Fuel System Pressure

- Standard
- Low

Control System

Controller

- EMCP 4.3
- EMCP 4.4

Attachments

- Local annunciator module
- Remote annunciator module
- Load share module
- Remote monitoring software

Charging

- Battery charger – 20A
- Battery charger – 35A
- Battery charger – 50A

Vibration Isolators

- Rubber
- Spring
- Seismic rated

Cat Connect

Connectivity

- Ethernet

Extended Service Options

Terms

- 2 year
- 3 year
- 5 year
- 10 year

Coverage

- Silver
- Gold
- Platinum
- Platinum Plus

Ancillary Equipment

- Automatic transfer switch (ATS)
- Uninterruptible power supply (UPS)
- Paralleling switchgear
- Paralleling controls

Certifications

- UL 2200 Listed
- CSA Certified

Note: Some options may not be available on all models. Certifications may not be available with all model configurations. Consult factory for availability.

Package Performance

Performance		Standby & Continuous			
Frequency	60 Hz				
Genset power rating @ 0.8 power factor – kW (kVA)	750 (938kVA)		1000 (1250)		
Emissions	Certified - U.S. EPA Stationary				
Performance number	EM4567-01 & EM4494-01		EM4565-01 & EM4492-01		
Fuel Consumption					
100% load with fan – MJ/ekW-hr (Btu/ekW-hr)	10.84	(10282)	10.29	(9757)	
75% load with fan – MJ/ekW-hr (Btu/ekW-hr)	11.60	(10994)	10.78	(10225)	
50% load with fan – MJ/ekW-hr (Btu/ekW-hr)	13.18	(12495)	11.84	(11227)	
Cooling System					
Radiator air flow restriction – kPa (in. water)	0.12	(0.5)	0.12	(0.5)	
Radiator air flow – m ³ /min (cfm)	1830	(64625)	1830	(64625)	
Radiator ambient capability @ 304 m (1000 ft) – °C (°F)	45	(113)	45	(113)	
Auxiliary circuit temperature (maximum inlet) – °C (°F)	54	(130)	54	(130)	
Jacket water temperature (maximum outlet) – °C (°F)	99	(210)	99	(210)	
Inlet Air					
Combustion air inlet flow rate – Nm ³ /bKW-hr (ft ³ /min)	4.59	(2451)	4.37	(3071)	
Altitude Capability					
At 25°C (77°F) ambient, above sea level – m (ft)	2862	(9390)	1928	(6325)	
Exhaust System					
Exhaust temperature – engine outlet – °C (°F)	512	(953)	512	(954)	
Exhaust Gas Flow – Nm ³ /bKW-hr (ft ³ /min)	4.88	(6955)	4.65	(8721)	
Exhaust Gas Mass Flow – kg/bkW-hr (lb/hr)	6.15	(11263)	5.85	(14116)	
Heat Rejection					
Heat rejection to jacket water circuit (JW+AC1+OC) – kW (Btu/min)	491	(27927)	611	(34726)	
Heat rejection to jacket water – kW (Btu/min)	364	(20683)	423	(24072)	
Heat rejection to exhaust (LHV to 120°C/248°F) – kW (Btu/min)	627	(35672)	1002	(44757)	
Auxiliary circuit temperature (maximum inlet) – °C (°F)	54	(130)	54	(130)	
Heat rejection to atmosphere from engine and generator – kW (Btu/min)	138	(7840)	153	(8705)	

Weights and Dimensions

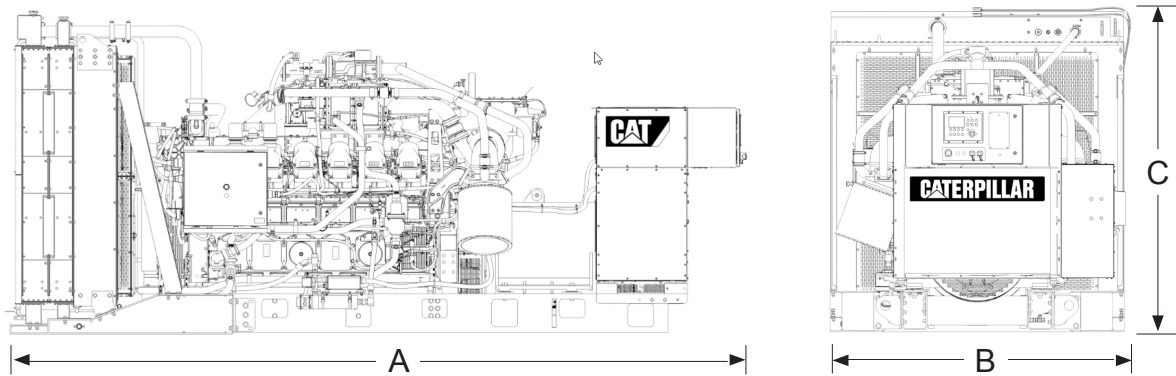

Dim "A" mm (in)	Dim "B" mm (in)	Dim "C" mm (in)	Dry Weight kg (lb)
6011(236)	2809 (110)	2671 (105)	12,500 (27,500)

Note: For reference only. Do not use for installation design. Contact your local Cat dealer for precise weights and dimensions.

Ratings Definitions

Standby

Output available with varying load for the duration of an emergency outage. Average power output is 100% of the standby power rating. Typical operation is 200 hours per year, with maximum expected usage of 500 hours per year.

Continuous

Output available with non-varying load for unlimited time. Average power output is 70-100% of the continuous power rating. Typical peak demand is 100% of continuous rating for 100% of the operating hours.

Applicable Codes and Standards

AS 1359, CSA C22.2 No. 100-04, UL 489, UL 869, UL 2200, NFPA37, NFPA70, NFPA99, NFPA110, IBC, IEC 60034-1, ISO 3046, ISO 8528, NEMA MG1-22, NEMA MG1-33, 2014/35/EU, 2006/42/EC, 2014/30/EU.

Note: Codes may not be available in all model configurations. Please consult your local Cat dealer for availability.

Fuel Rates

1. For transient response, ambient, and altitude capabilities consult your local Cat dealer.
2. Fuel pressure range specified is to the engine fuel control valve. Additional fuel train components may be required and should be considered in pressure and flow calculations.
3. For a complete reference of definitions and conditions see the following datasheets
 - a. 750ekw Standby / Emergency
EM4567 w/fan, EM4568 w/o fan
 - b. 750ekw Continuous / Standard
EM4494 w/fan, EM4495 w/o fan
 - c. 1000ekw Standby / Emergency
EM4565 w/fan, EM4566 w/o fan
 - d. 1000ekw Continuous / Standard
EM4492 w/fan, EM4493 w/o fan

www.cat.com/electricpower

©2021 Caterpillar
All rights reserved.

Materials and specifications are subject to change without notice.
The International System of Units (SI) is used in this publication.

CAT, CATERPILLAR, LET'S DO THE WORK, their respective logos, "Caterpillar Yellow", the "Power Edge" and Cat "Modern Hex" trade dress as well as corporate and product identity used herein, are trademarks of Caterpillar and may not be used without permission