



Cat[®] 415

BACKHOE LOADER

The Cat[®] 415 Backhoe Loader delivers exceptional performance, increased fuel efficiency, superior hydraulic system and an updated operator station. The 415 features the following:

- **Ergonomic Operator Station** – Ample legroom inside the cab makes rotating the seat simple. The air suspension seat provides comfort to the operator while roading.
- **Joystick Controls** – Pilot joysticks are available for additional operator comfort, reduced fatigue and increased productivity. New Proportional Thumb Rollers on the Pilot Joysticks places E-Stick and Rear Auxiliary Controls at the operator's fingertips.
- **Load Sensing Hydraulics** – The Cat Backhoe Loader's load sensing piston pump provides full hydraulic lifting and digging forces at any engine speed. Variable flow pump matches hydraulic power to work demands.
- **Machine Performance** – The proven Cat C3.6 engine delivers solid performance, meets U.S. EPA Tier 4 Final/EU Stage V emission standards, and requires no diesel exhaust fluid (DEF).
- **Machine Versatility** – The all new Integrated Tool Carrier (IT Coupler) for Single Tilt Loader Arm configurations are available from the factory or for simple field installation. The Cat Backhoe Loader with Integrated Tool Carrier (IT Coupler) will be the most versatile machine on the job site providing quick connection to a variety of Cat Attachments.
- **Cat Attachments** – A large portfolio of Backhoe Loader Attachments, including but not limited to, Quick Couplers, Thumbs, assorted Buckets, and Brooms are available from the factory or for field installation. Cat Backhoe Loaders will be "Dirt Ready" upon delivery.

Specifications

Engine

Engine	C3.6 55 kW (74 hp) Electronic Turbo Intercooled	
Ratings at 2,200 rpm		
Gross Power SAE J1995	56 kW	75 hp
Gross Power ISO 14396	55 kW	74 hp
Net Power Rating at 2,200 rpm		
SAE J1349	52 kW	70 hp
ISO 9249	52 kW	69 hp
Net Peak Power Rating @ 2,200 rpm		
SAE J1349	52 kW	70 hp
ISO 9249	53 kW	71 hp
Dimensions		
Bore	98 mm	3.86 in
Stroke	120 mm	4.72 in
Displacement	3.6 L	220 in ³
Torque Rise (net) at 1,400 rpm	85%	
SAE J1349 Net	418 N-m	308 lb-ft
Power Rating Conditions		
No de-rating required up to	3048 m	10,000 ft

- Engine meets U.S. EPA Tier 4 Final/EU Stage V emission standards.

Weights*

Operating Weight* (estimated)	7384 kg	16,279 lb
Operating Weight (maximum) (Rollover Protective Structure [ROPS] capacity)	11 000 kg	24,251 lb
Operating Weight (minimum) Cab, ROPS/Falling Object Protective Structure (FOPS)	6997 kg	15,426 lb
Auto-Shift Transmission	122 kg	269 lb
Ride Control	15 kg	33 lb
Air Conditioning	45 kg	99 lb
All-Wheel Drive	STD	STD
MP bucket (0.96 m ³ /1.25 yd ³) with fold-over forks	915 kg	2,017 lb
without fold-over forks	745 kg	1,642 lb
Loader QC	245 kg	540 lb
Extendible Stick (excludes ft. counterweight)	278 kg	613 lb
Counterweights, base	115 kg	256 lb
Stackable, one	240 kg	529 lb
Maximum	460 kg	1,014 lb

*Machine configuration: standard stick hoe, Open Roll Over Protective Structure (OROPS) canopy, 4 Wheel Drive (4WD) standard shift transmission, 0.96 m³ (1.25 yd³) GP (General Purpose) loader bucket, 610 mm (24 in) standard duty hoe bucket, front 340/80-18 and rear 500/70-24 tires, 240 kg (530 lb) counterweight, 80 kg (176 lb) operator, full fuel tank.



415 Backhoe Loader

Transmission*

Power Shuttle Transmission – Standard

Forward – 1st	5.5 km/h	3.4 mph
2nd	9.1 km/h	5.7 mph
3rd	21 km/h	13 mph
4th	38 km/h	23 mph
Reverse – 1st	5.5 km/h	3.4 mph
2nd	9.1 km/h	5.7 mph
3rd	21 km/h	13 mph
4th	38 km/h	23 mph

Power-Shift Transmission – Optional

Forward – 1st	5.9 km/h	3.7 mph
2nd	9.4 km/h	5.8 mph
3rd	20 km/h	12 mph
4th	40 km/h	25 mph
Reverse – 1st	5.9 km/h	3.7 mph
2nd	12 km/h	7.6 mph
3rd	27 km/h	17 mph

*Travel speeds of backhoe loader at full throttle, when equipped with 500/70-24 rear tires.

Axle Ratings

Front Axle, All Wheel Drive (AWD)

Static	23 500 kg	51,808 lb
Dynamic	9000 kg	19,841 lb

Rear Axle

Static	26 500 kg	58,422 lb
Dynamic	10 000 kg	22,046 lb

Hydraulic System

Type	Closed Center	
Pump Type	Variable-flow, Axial Piston	
Pump Capacity @ 2,200 rpm	132 L/min	34.9 gal/min
System Pressure		
Backhoe	23 000 kPa	3,336 psi
Loader	23 000 kPa	3,336 psi

Steering

Type	Front Wheel Steering	
Power Steering	Hydrostatic	
One Double-Acting Cylinder		
Bore	65 mm	2.6 in
Stroke	106 mm	4.2 in
Rod Diameter	40 mm	1.6 in
Axle Oscillation	11°	
Turning Circle – (inner wheel not braked)		
Outside Front Wheels	8.205 m	26'11"
Outside Widest Loader Bucket	10.745 m	35'3"

Service Refill Capacities

Cooling System with Air Conditioning	18.0 L	4.8 gal
Fuel Tank	160.0 L	42.3 gal
Engine Oil with Filter	9.0 L	2.4 gal
Transmission – Power Shuttle		
AWD	18.0 L	4.8 gal
Transmission – Power Shift		
AWD	19.0 L	5.0 gal
Rear Axle	16.0 L	4.2 gal
Planetaries	1.7 L	0.4 gal
Front Axle (AWD)	11.0 L	2.9 gal
Planetaries	0.7 L	0.2 gal
Hydraulic System	95.0 L	25.1 gal
Hydraulic Tank	42.0 L	11.1 gal

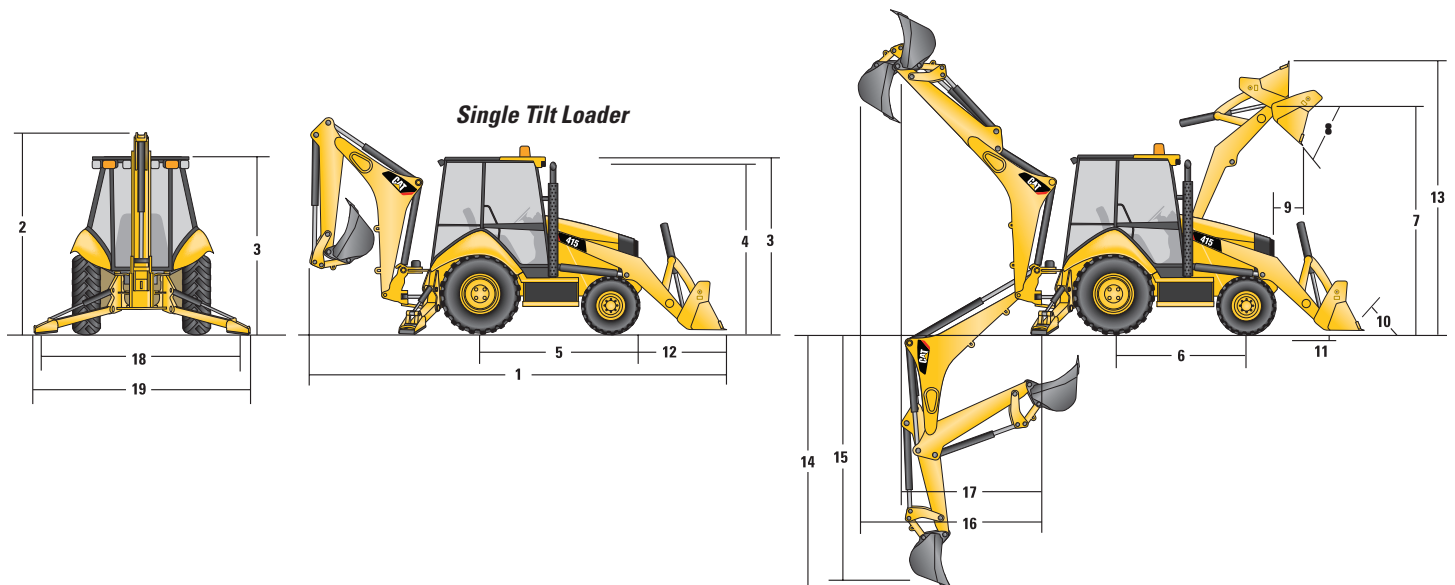

Dimensions

Machine configuration: standard stick hoe, OROPS canopy, 4WD standard shift transmission, 0.96 m³ (1.25 yd³) GP loader bucket, 610 mm (24 in) standard duty hoe bucket, front 340/80-18 and rear 500/70-24 tires, 240 kg (530 lb) counterweight, 80 kg (176 lb) operator, full fuel tank.

Single Tilt with Pin-On Buckets

	0.76 m ³ (1.0 yd ³) GP	0.96 m ³ (1.25 yd ³) GP	1.0 m ³ (1.31 yd ³) GP	1.07 m ³ (1.40 yd ³) GP	1.0 m ³ (1.31 yd ³) MP	1.07 m ³ (1.40 yd ³) MP
1 Overall Length (loader on ground) – S-Stick – mm (ft/in)	7018 (23'0")	7131 (23'5")	7086 (23'3")	7151 (23'6")	7059 (23'2")	7059 (23'2")
Overall Length (loader on ground) – E-Stick – mm (ft/in)	7024 (23'1")	7136 (23'5")	7091 (23'3")	7157 (23'6")	7064 (23'2")	7064 (23'2")
Overall Transport Length – S-Stick – mm (ft/in)	7079 (23'3")	7162 (23'6")	7128 (23'5")	7199 (23'7")	7129 (23'5")	7129 (23'5")
Overall Transport Length – E-Stick – mm (ft/in)	7084 (23'3")	7188 (23'7")	7134 (23'5")	7205 (23'8")	7135 (23'5")	7135 (23'5")
2 Overall Transport Height – Standard Stick – mm (ft/in)	3646 (12'0")	3646 (12'0")	3646 (12'0")	3646 (12'0")	3646 (12'0")	3646 (12'0")
Overall Transport Height – Extendible Stick – mm (ft/in)	3666 (12'0")	3666 (12'0")	3666 (12'0")	3666 (12'0")	3666 (12'0")	3666 (12'0")
Overall Width – mm (ft/in)	2248 (7'5")	2248 (7'5")	2248 (7'5")	2248 (7'5")	2248 (7'5")	2248 (7'5")
3 Height to Top of Cab/Canopy – mm (ft/in)	2815 (9'3")	2815 (9'3")	2815 (9'3")	2815 (9'3")	2815 (9'3")	2815 (9'3")
4 Height to Top of Exhaust Stack – mm (ft/in)	2720 (8'11")	2720 (8'11")	2720 (8'11")	2720 (8'11")	2720 (8'11")	2720 (8'11")
Height to Loader Hinge Pin (transport) – mm (ft/in)	379 (1'3")	378 (1'3")	378 (1'3")	422 (1'5")	420 (1'5")	420 (1'5")
Ground Clearance (LH step) – mm (ft/in)	316 (1'0")	316 (1'0")	316 (1'0")	316 (1'0")	316 (1'0")	316 (1'0")
Ground Clearance (AWD guard) – mm (ft/in)	312 (1'0")	312 (1'0")	312 (1'0")	312 (1'0")	312 (1'0")	312 (1'0")
Ground Clearance (485 kg/1,070 lb counterweight) – mm (ft/in)	289 (0'11")	289 (0'11")	289 (0'11")	289 (0'11")	289 (0'11")	289 (0'11")
5 Rear Axle Centerline to Front Grill – mm (ft/in)	2706 (8'11")	2706 (8'11")	2706 (8'11")	2706 (8'11")	2706 (8'11")	2706 (8'11")
Front Wheel Tread Gauge – mm (ft/in)	1895 (6'3")	1895 (6'3")	1895 (6'3")	1895 (6'3")	1895 (6'3")	1895 (6'3")
Rear Wheel Tread Gauge – mm (ft/in)	1728 (5'8")	1728 (5'8")	1728 (5'8")	1728 (5'8")	1728 (5'8")	1728 (5'8")
6 Wheelbase – mm (ft/in)	2200 (7'3")	2200 (7'3")	2200 (7'3")	2200 (7'3")	2200 (7'3")	2200 (7'3")

Single Tilt Loader with Quick Coupler

	0.96 m ³ (1.25 yd ³) GP	1.0 m ³ (1.31 yd ³) GP	1.15 m ³ (1.50 yd ³) GP	1.0 m ³ (1.31 yd ³) MP	1.07 m ³ (1.40 yd ³) MP
1 Overall Length (loader on ground) – S-Stick – mm (ft/in)	7312 (24'0")	7268 (23'10")	7310 (24'0")	7219 (23'8")	7219 (23'8")
Overall Length (loader on ground) – E-Stick – mm (ft/in)	7318 (24'0")	7273 (23'10")	7315 (24'0")	7225 (23'8")	7225 (23'8")
Overall Transport Length – S-Stick – mm (ft/in)	7289 (23'11")	7255 (23'10")	7287 (23'11")	7217 (23'8")	7217 (23'8")
Overall Transport Length – E-Stick – mm (ft/in)	7295 (23'11")	7261 (23'10")	7293 (23'11")	7223 (23'8")	7223 (23'8")
2 Overall Transport Height – Standard Stick – mm (ft/in)	3646 (12'0")	3646 (12'0")	3646 (12'0")	3646 (12'0")	3646 (12'0")
Overall Transport Height – Extendible Stick – mm (ft/in)	3666 (12'0")	3666 (12'0")	3666 (12'0")	3666 (12'0")	3666 (12'0")
Overall Width – mm (ft/in)	2248 (7'5")	2248 (7'5")	2248 (7'5")	2248 (7'5")	2248 (7'5")
3 Height to Top of Cab/Canopy – mm (ft/in)	2815 (9'3")	2815 (9'3")	2815 (9'3")	2815 (9'3")	2815 (9'3")
4 Height to Top of Exhaust Stack – mm (ft/in)	2720 (8'11")	2720 (8'11")	2720 (8'11")	2720 (8'11")	2720 (8'11")
Height to Loader Hinge Pin (transport) – mm (ft/in)	345 (1'2")	346 (1'2")	346 (1'2")	344 (1'2")	344 (1'2")
Ground Clearance (LH step) – mm (ft/in)	316 (1'0")	316 (1'0")	316 (1'0")	316 (1'0")	316 (1'0")
Ground Clearance (AWD guard) – mm (ft/in)	312 (1'0")	312 (1'0")	312 (1'0")	312 (1'0")	312 (1'0")
Ground Clearance (485 kg/1,070 lb counterweight) – mm (ft/in)	289 (0'11")	289 (0'11")	289 (0'11")	289 (0'11")	289 (0'11")
5 Rear Axle Centerline to Front Grill – mm (ft/in)	2706 (8'11")	2706 (8'11")	2706 (8'11")	2706 (8'11")	2706 (8'11")
Front Wheel Tread Gauge – mm (ft/in)	1895 (6'3")	1895 (6'3")	1895 (6'3")	1895 (6'3")	1895 (6'3")
Rear Wheel Tread Gauge – mm (ft/in)	1728 (5'8")	1728 (5'8")	1728 (5'8")	1728 (5'8")	1728 (5'8")
6 Wheelbase – mm (ft/in)	2200 (7'3")	2200 (7'3")	2200 (7'3")	2200 (7'3")	2200 (7'3")

415 Backhoe Loader

Dimensions

Machine configuration: standard stick hoe, OROPS canopy, 4WD standard shift transmission, 0.96 m³ (1.25 yd³) GP loader bucket, 610 mm (24 in) standard duty hoe bucket, front 340/80-18 and rear 500/70-24 tires, 240 kg (530 lb) counterweight, 80 kg (176 lb) operator, full fuel tank.

Loader Bucket Dimensions and Performance

	Pin-On Buckets											
	0.76 m ³ (1.0 yd ³) GP		0.96 m ³ (1.25 yd ³) GP		1.0 m ³ (1.31 yd ³) GP		1.07 m ³ (1.40 yd ³) GP		1.0 m ³ (1.31 yd ³) MP		1.07 m ³ (1.40 yd ³) MP	
Capacity (SAE rated) – m ³ (yd ³)	0.76	(1.0)	0.96	(1.26)	1.00	(1.31)	1.07	(1.40)	1.00	(1.31)	1.07	(1.40)
Overall Bucket Width – mm (in)	2262	(89)	2262	(89)	2406	(95)	2262	(89)	2279	(90)	2425	(95)
Lift Capacity at Maximum Height – kg (lb)	3053	(6,730)	2962	(6,530)	2967	(6,541)	2900	(6,393)	2736	(6,032)	2724	(6,005)
Lift Breakout Force – N (lbf)	48 282	(10,854)	45 673	(10,267)	46 360	(10,422)	45 164	(10,153)	44 481	(9,999)	44 385	(9,978)
Tilt Breakout Force – N (lbf)	54 304	(12,207)	45 719	(10,278)	48 604	(10,926)	46 676	(10,493)	51 462	(11,569)	51 386	(11,551)
Tipping Load at Breakout Point – kg (lb)	6969	(15,363)	6486	(14,298)	6640	(14,638)	6387	(14,081)	6515	(14,363)	6505	(14,342)
7 Maximum Hinge Pin Height – mm (ft/in)	3488	(11'5")	3488	(11'5")	3488	(11'5")	3488	(11'5")	3488	(11'5")	3488	(11'5")
8 Dump Angle at Full Height – degrees	44°		44°		44°		44°		44°		44°	
Dump Height at Maximum Angle – mm (ft/in)	2837	(9'4")	2758	(9'1")	2790	(9'2")	2736	(9'0")	2803	(9'2")	2803	(9'2")
9 Dump Reach at Maximum Angle – mm (ft/in)	726	(2'5")	807	(2'8")	774	(2'6")	773	(2'6")	722	(2'4")	722	(2'4")
10 Maximum Bucket Rollback at Ground Level – degrees	36°		36°		36°		37°		37°		37°	
11 Digging Depth – mm (ft/in)	70	(0'3")	70	(0'3")	70	(0'3")	110	(0'4")	97	(0'4")	97	(0'4")
Maximum Grading Angle – degrees	116°		113°		114°		114°		116°		116°	
Width of Dozer Cutting Edge – mm (ft/in)	N/A		N/A		N/A		N/A		2262	(7'5")	2406	(7'11")
12 Grill to Bucket Cutting Edge, Carry Position – mm (ft/in)	1397	(4'7")	1480	(4'10")	1447	(4'9")	1518	(5'0")	1447	(4'9")	1447	(4'9")
13 Maximum Operating Height – mm (ft/in)	4206	(13'10")	4356	(14'3")	4354	(14'3")	4366	(14'4")	4378	(14'4")	4407	(14'6")
Jaw Opening Maximum – mm (ft/in)	N/A		N/A		N/A		N/A		843	(2'9")	843	(2'9")
Bucket Jaw Clamping Force – N (lbf)	N/A		N/A		N/A		N/A		37 113	(8,343)	37 214	(8,366)
Weight (does not include teeth or forks) – kg (lb)	384	(847)	451	(994)	462	(1,019)	473	(1,043)	745	(1,642)	774	(1,706)

	Single Tilt Loader with Quick Coupler									
	0.96 m ³ (1.25 yd ³) GP		1.0 m ³ (1.31 yd ³) GP		1.15 m ³ (1.50 yd ³) GP		1.0 m ³ (1.31 yd ³) MP		1.07 m ³ (1.40 yd ³) MP	
Capacity (SAE rated) – m ³ (yd ³)	0.96	(1.26)	1.00	(1.31)	1.15	(1.50)	1.00	(1.31)	1.07	(1.40)
Overall Bucket Width – mm (in)	2262	(89)	2406	(95)	2406	(95)	2279	(90)	2425	(95)
Lift Capacity at Maximum Height – kg (lb)	2579	(5,686)	2579	(5,686)	2546	(5,612)	2438	(5,375)	2402	(5,296)
Lift Breakout Force – N (lbf)	40 911	(9,197)	41 450	(9,318)	40 608	(9,129)	40 289	(9,057)	40 029	(8,999)
Tilt Breakout Force – N (lbf)	37 640	(8,462)	39 574	(8,896)	37 351	(8,396)	40 227	(9,043)	40 055	(9,004)
Tipping Load at Breakout Point – kg (lb)	5721	(12,612)	5841	(12,876)	5696	(12,556)	5811	(12,812)	5787	(12,757)
7 Maximum Hinge Pin Height – mm (ft/in)	3488	(11'5")	3488	(11'5")	3488	(11'5")	3488	(11'5")	3488	(11'5")
8 Dump Angle at Full Height – degrees	44°		44°		44°		44°		44°	
Dump Height at Maximum Angle – mm (ft/in)	2623	(8'7")	2654	(8'9")	2625	(8'7")	2690	(8'10")	2690	(8'10")
9 Dump Reach at Maximum Angle – mm (ft/in)	887	(2'11")	855	(2'10")	886	(2'11")	832	(2'9")	832	(2'9")
10 Maximum Bucket Rollback at Ground Level – degrees	37°		37°		37°		37°		37°	
11 Digging Depth – mm (ft/in)	111	(0'4")	111	(0'4")	110	(0'4")	101	(0'4")	101	(0'4")
Maximum Grading Angle – degrees	109°		110°		109°		111°		111°	
Width of Dozer Cutting Edge – mm (ft/in)	N/A		N/A		N/A		2262	(7'5")	2406	(7'11")
12 Grill to Bucket Cutting Edge, Carry Position – mm (ft/in)	1607	(5'3")	1573	(5'2")	1605	(5'3")	1535	(5'0")	1535	(5'0")
13 Maximum Operating Height – mm (ft/in)	4439	(14'7")	4406	(14'5")	4484	(14'9")	4476	(14'8")	4531	(14'10")
Jaw Opening Maximum – mm (ft/in)	N/A		N/A		N/A		843	(2'9")	843	(2'9")
Bucket Jaw Clamping Force – N (lbf)	N/A		N/A		N/A		37 136	(8,348)	37 237	(8,371)
Weight (does not include teeth or forks) – kg (lb)	447	(985)	457	(1,008)	481	(1,060)	724	(1,596)	753	(1,660)

Dimensions

Machine configuration: standard stick hoe, OROPS canopy, 4WD standard shift transmission, 0.96 m³ (1.25 yd³) GP loader bucket, 610 mm (24 in) standard duty hoe bucket, front 340/80-18 and rear 500/70-24 tires, 240 kg (530 lb) counterweight, 80 kg (176 lb) operator, full fuel tank.

Backhoe Dimensions and Performance

	Standard Stick		E-Stick Retracted		E-Stick Extended	
14 Digging Depth, SAE (max.) – mm (ft/in)	4277	(14'0")	4317	(14'2")	5371	(17'7")
15 Digging Depth, 2438 mm (8 ft) Flat Bottom – mm (ft/in)	3899	(12'9")	3942	(12'11")	5072	(16'8")
Digging Depth, 610 mm (2 ft) Flat Bottom – mm (ft/in)	4239	(13'11")	4279	(14'0")	5334	(17'6")
Reach from Rear Axle Centerline at Ground Line – mm (ft/in)	6690	(21'11")	6726	(22'1")	7731	(25'4")
16 Reach from Swing Pivot at Ground Line – mm (ft/in)	5600	(18'4")	5636	(18'6")	6641	(21'9")
Maximum Operating Height – mm (ft/in)	5601	(18'5")	5625	(18'5")	6368	(20'11")
Loading Height – mm (ft/in)	3710	(12'2")	3667	(12'0")	4238	(13'11")
17 Loading Reach – mm (ft/in)	1841	(6'0")	1928	(6'4")	2846	(9'4")
Swing Arc	180°		180°		180°	
Bucket Rotation	205°		204°		204°	
18 Stabilizer Spread, Operating Position (center) – mm (ft/in)	3310	(10'10")	3310	(10'10")	3310	(10'10")
Stabilizer Spread, Operating Position (outside) – mm (ft/in)	3770	(12'4")	3770	(12'4")	3770	(12'4")
Stabilizer Spread, Transport Position – mm (ft/in)	2322	(7'7")	2322	(7'7")	2322	(7'7")
Bucket Dig Force – N (lbf)	59 119	(13,291)	58 289	(13,104)	58 289	(13,104)
Stick Dig Force – N (lbf)	32 374	(7,278)	32 417	(7,288)	23 800	(5,350)

Dimensions with Forks/Material Handling Arm

Fork Tine Length	1070 mm (3'6")		1220 mm (4'0")		1370 mm (4'10")	
Operating Load (SAE J1197) – kg (lb)	1758	(3,875)	1684	(3,713)	1615	(3,559)
SAE Load Center – mm (in)	535	(1'9")	610	(2'0")	685	(2'3")
Operating Load (CEN 474-4) – kg (lb)	1786	(3,938)	1771	(3,904)	1754	(3,867)
CEN Load Center – mm (ft/in)	500	(1'8")	500	(1'8")	500	(1'8")
Overall Length (A) (forks on ground) – mm (ft/in)	7647	(25'1")	7797	(25'7")	7946	(26'1")
Reach at Ground (from grill to heel of fork) – mm (ft/in)	939	(3'1")	939	(3'1")	938	(3'1")
Maximum Reach (from grill to heel of fork) – mm (ft/in)	1524	(5'0")	1524	(5'0")	1524	(5'0")
Fork Height at Maximum Reach – mm (ft/in)	1619	(5'4")	1619	(5'4")	1619	(5'4")
Reach at Maximum Height (from grill to heel of fork) – mm (ft/in)	749	(2'5")	749	(2'5")	749	(2'5")
Maximum Fork Height – mm (ft/in)	3418	(11'3")	3418	(11'3")	3418	(11'3")
Maximum Fork Depth (below ground level) – mm (ft/in)	-38	(-1'11")	-38	(-1'10")	-39	(-1'10")

Material Handling Arm Position	Retracted		Mid-Position		Extended	
Operating Load (SAE J1197 and CEN 474-4) – kg (lb)*	1091	(2,404)	733	(1,615)	531	(1,171)
Overall Length, Maximum – mm (ft/in)	8903	(29'3")	9903	(32'6")	10 901	(35'9")
Reach at Maximum Depth (from machine nose) – mm (ft/in)	544	(1'9")	550	(1'10")	557	(1'10")
Maximum Depth – mm (ft/in)	2618	(8'7")	3618	(11'10")	4616	(15'2")
Maximum Reach (from machine nose) – mm (ft/in)	3221	(10'7")	4221	(13'10")	5219	(17'1")
Height at Maximum Reach – mm (ft/in)	1118	(3'8")	1124	(3'8")	1130	(3'8")
Reach at Maximum Height (from machine nose) – mm (ft/in)	1783	(5'10")	2473	(8'1")	3161	(10'4")
Maximum Height – mm (ft/in)	4445	(14'7")	5169	(16'11")	5891	(19'4")

*These numbers are hydraulically limited.

415 Backhoe Loader

Backhoe Lift Capacity

Cat 415 Standard Stick

Boom Lifting	kg	lb
1	1334	2,941
2	1426	3,144
3	1407	3,101
4	1353	2,983
5	1292	2,849
6	1232	2,716
7	1174	2,589
8	1120	2,469
9	1069	2,358
10	1022	2,254
11	979	2,158
12	939	2,071
13	905	1,996
14	885	1,952
15	916	2,019
Stick Lifting		
16	1568	3,456
17	1916	4,224
18	2328	5,133
19	2436	5,371
20	2884	6,358
21	3540	7,805

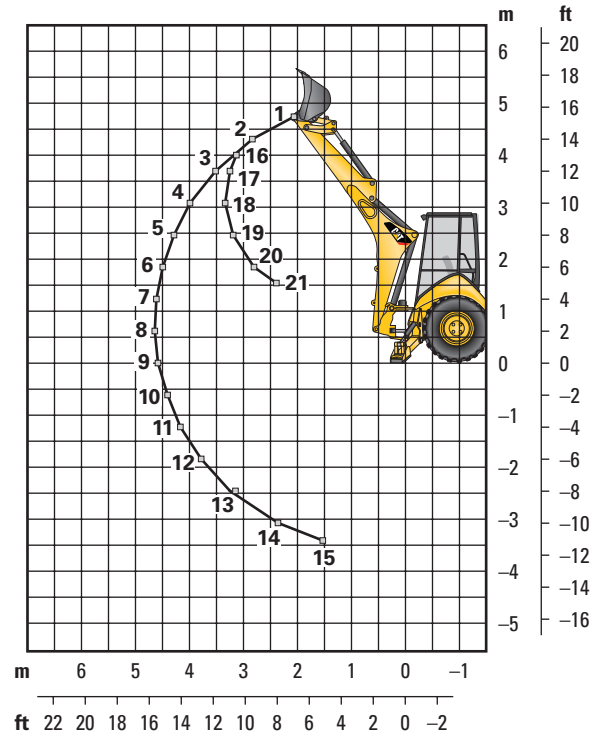

Cat 415 Extendible Stick – Retracted

Boom Lifting	kg	lb
1	1157	2,551
2	1235	2,722
3	1208	2,664
4	1153	2,541
5	1091	2,404
6	1029	2,269
7	970	2,139
8	915	2,017
9	863	1,902
10	814	1,794
11	768	1,692
12	725	1,597
13	684	1,509
14	650	1,432
15	647	1,427
Stick Lifting		
16	1423	3,138
17	1754	3,866
18	2128	4,692
19	2226	4,908
20	2629	5,796
21	3189	7,030
22	0	0

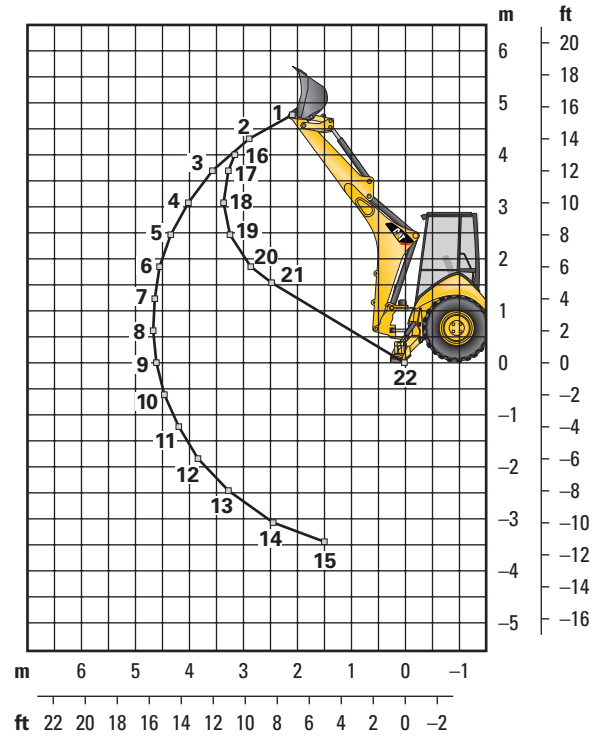

Lift capacities are over-end values calculated according to SAE J31. Values are 87% of the maximum lift force available. Machine equipped with AWD, OROPS, 0.96 m³ (1.25 yd³) general purpose bucket and no counterweight. Extendible stick includes 460 kg (1,015 lb) counterweight.

Backhoe Lift Capacity

Cat 415 Extendible Stick – Extended

Boom Lifting			
		kg	lb
1		640	1,412
2		771	1,700
3		802	1,767
4		799	1,761
5		782	1,724
6		759	1,673
7		733	1,616
8		706	1,557
9		680	1,498
10		654	1,442
11		630	1,388
12		607	1,339
13		587	1,295
14		571	1,259
15		561	1,237
16		566	1,248
17		648	1,429
18		867	1,911
Stick Lifting			
19		597	1,316
20		767	1,692
21		1008	2,222
22		1178	2,597
23		1322	2,915
24		1479	3,260
25		1711	3,773
26		2305	5,082
27		3506	7,730

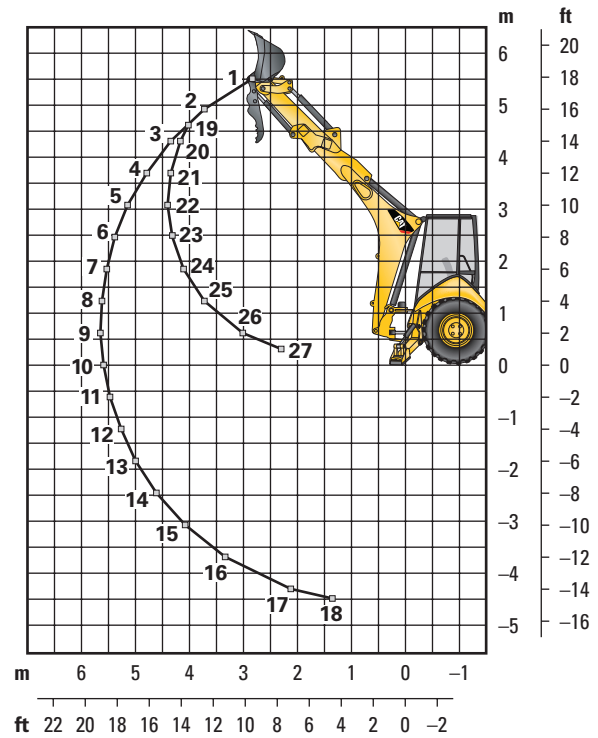

Lift capacities are over-end values calculated according to SAE J31. Values are 87% of the maximum lift force available.
 Machine equipped with AWD, DROPS, 0.96 m³ (1.25 yd³) general purpose bucket and no counterweight.
 Extendible stick includes 460 kg (1,015 lb) counterweight.

415 Backhoe Loader

Counterweights (Minimum Counterweight Recommendations)

Standard Stick Loader Bucket	Pin-On Bucket		Loader QC	
	kg	lb	kg	lb
GP	115	255	0	0
MP	0	0	0	0
Forks	N/A	N/A	0	0
Material Handling Arm	N/A	N/A	0	0

Extendible Stick Loader Bucket	Pin-On Bucket		Loader QC	
	kg	lb	kg	lb
GP	460	1,015	240	530
MP	115	255	0	0
Forks	N/A	N/A	240	530
Material Handling Arm	N/A	N/A	240	530

Backhoe Buckets (With weld on adapters and pin-on teeth)

Standard Duty

Width		Rated Capacity		Weight		No. of Teeth
mm	in	L	ft ³	kg	lb	
305	12	80	2.8	111	245	3
457	18	120	4.2	122	268	4
610	24	180	6.4	141	311	5
762	30	230	8.1	157	345	5
914	36	290	10.2	176	388	6

Heavy Duty

Width		Rated Capacity		Weight		No. of Teeth
mm	in	L	ft ³	kg	lb	
305	12	80	2.8	121	266	3
406	16	110	3.9	128	282	3
457	18	120	4.2	135	299	4
610	24	180	6.4	160	353	5
762	30	230	8.1	177	391	5
914	36	290	10.2	201	443	6

Soil Excavation

Width		Rated Capacity		Weight		No. of Teeth
mm	in	L	ft ³	kg	lb	
457	18	180	6.4	155	341	4
610	24	240	8.5	182	402	5
762	30	320	11.3	206	454	5
914	36	380	13.4	233	513	6

Rock

Width		Rated Capacity		Weight		No. of Teeth
mm	in	L	ft ³	kg	lb	
305	12	70	2.5	127	279	3
457	18	130	4.6	146	322	4
610	24	200	7.1	174	384	5
762	30	270	9.5	197	434	5
914	36	330	11.7	224	493	6

Coral

Width		Rated Capacity		Weight		No. of Teeth
mm	in	L	ft ³	kg	lb	
305	12	60	2.1	134	295	4
457	18	100	3.5	155	341	6
610	24	140	4.9	182	402	8
762	30	190	6.7	210	463	10

The following information applies to the machine at the time of final manufacture as configured for sale in the regions covered in this document. The content of this declaration is valid as of the date issued; however, content related to machine features and specifications are subject to change without notice. For additional information, please see the machine's Operation and Maintenance Manual.

For more information on sustainability in action and our progress, please visit <https://www.caterpillar.com/en/company/sustainability>.

Engine

- The Cat® C3.6 engine meets U.S. EPA Tier 4 Final and EU Stage V emission standards.
- Cat diesel engines are required to use ULSD (ultra-low sulfur diesel fuel with 15 ppm of sulfur or less) or ULSD blended with the following lower-carbon intensity fuels up to:
 - ✓ 20% biodiesel FAME (fatty acid methyl ester)
 - ✓ 100% renewable diesel, HVO (hydrotreated vegetable oil) and GTL (gas-to-liquid) fuels
 Refer to guidelines for successful application. Please consult your Cat dealer or "Caterpillar Machine Fluids Recommendations" (SEBU6250) for details.

Air Conditioning System

- The air conditioning system on this machine contains the fluorinated greenhouse gas refrigerant R134a (Global Warming Potential = 1430). The system contains 1.6 kg (3.5 lb) of refrigerant which has a CO₂ equivalent of 2.3 metric tonnes (2.5 tons).

Paint

- Based on best available knowledge, the maximum allowable concentration, measured in parts per million (PPM), of the following heavy metals in paint are:
 - Barium < 0.01%
 - Cadmium < 0.01%
 - Chromium < 0.01%
 - Lead < 0.01%

Sound Performance

Operator Sound Pressure Level (ISO 6396:2008) – 76 dB(A)*

Exterior Sound Power Level (ISO 6395:2008) – 101 dB(A)

*Measurements were conducted with properly installed and maintained cab doors and windows closed.

Oils and Fluids

- Caterpillar factory fills with ethylene glycol coolants. Cat Diesel Engine Antifreeze/Coolant (DEAC) and Cat Extended Life Coolant (ELC) can be recycled. Consult your Cat dealer for more information.
- Cat Bio HYDO™ Advanced is an EU Ecolabel approved biodegradable hydraulic oil.
- Additional fluids are likely to be present, please consult the Operations and Maintenance Manual or the Application and Installation guide for complete fluid recommendations and maintenance intervals.

Features and Technology

- The following features and technology may contribute to fuel savings and/or carbon reduction. Features may vary. Consult your Cat dealer for details.
 - Save fuel and reduce your greenhouse gas emissions with efficiency features such as operator control modes selectable through the display and with fuel management modes.
 - Extended maintenance intervals not only reduce downtime but decrease the amount of fluid and filters that are replaced over the life of the machine.
 - Auto Idle helps reduce unnecessary fuel burn and greenhouse gas emissions by allowing the engine to automatically go into idle mode when the machine is not working.

Recycling

- The materials included in machines are categorized as below with approximate weight percentage. Because of variations of product configurations, the following values in the table may vary.

Material Type	Weight Percentage
Steel	60.51%
Iron	16.77%
Nonferrous Metal	3.29%
Mixed Metal	0.63%
Mixed-Metal and Nonmetal	1.03%
Plastic	2.13%
Rubber	3.01%
Mixed Nonmetallic	0.03%
Fluid	4.17%
Other	6.33%
Uncategorized	2.10%
Total	100.00%

- A machine with higher recyclability rate will ensure more efficient usage of valuable natural resources and enhance End-of-Life value of the product. According to ISO 16714 (Earthmoving machinery – Recyclability and recoverability – Terminology and calculation method), recyclability rate is defined as percentage by mass (mass fraction in percent) of the new machine potentially able to be recycled, reused, or both.

All parts in the bill of material are first evaluated by component type based on a list of components defined by the ISO 16714 and Japan CEMA (Construction Equipment Manufacturers Association) standards. Remaining parts are further evaluated for recyclability based on material type.

Because of variations of product configurations, the following value in the table may vary.

Recyclability – 92%

415 Standard Equipment

STANDARD EQUIPMENT

- Air cleaner
- Alarm, back-up
- Audible system fault alarm
- Backhoe controls, mechanical two lever
- Battery, maintenance-free, 850 CCA
- Battery disconnect switch
- Boom transport lock
- Brace, lift cylinder
- Brake, parking, mechanical
- Brakes, hydraulically boosted, oil disc, dual pedals, interlocking
- Bucket level indicator
- Canopy, ROPS/FOPS
- Coat restraint
- Coolant/antifreeze, extended life
- Dome light (cab only)
- Diagnostic port for engine
- Differential lock, loader joystick
- Drink holders, two
- Engine, Cat C3.6 (Direct Injection Turbocharged), meets Tier 4 Final/Stage V emission standards, diesel particulate filter
- Engine enclosure, sound suppression, removable side panels
- Face seals, O-ring
- Fan, suction and guard
- Fast reversing shuttle, all gears
- Fenders, rear
- Filters, spin-on: fuel, engine oil, transmission oil, water separator
- Filters, bowl and cartridge: hydraulic fluid
- Flashing hazards/signal lights
- Floor mat
- Four wheel drive
- Four wheel drive shaft guard
- Fuel tank, fully enclosed
- Fully hinged front grill for cooling package cleaning access
- Gauge cluster: coolant temperature, fuel level, torque converter temperature, battery voltage
- Ground level fuel fill
- Halogen Lights, working (2 front, 2 rear)
- High ambient cooling package
- Hood lock, inside cab
- Hydraulic hose, XT™
- Hydraulic oil cooler
- Hydraulic oil level sight gauge
- Hydraulic valves, loader 2 function
- Hydraulic valves, backhoe 4 function
- Hydraulics, load sensing with variable displacement piston pump
- Indicator lights: wait to start, water in fuel, engine warning, warning lamp, regeneration inhibited, low engine oil pressure; LCD warnings: machine locked, service due, air filter blocked, auto idle shutdown, high coolant temperature, high torque converter temperature, high exhaust temperature, engine oil life indicator
- Instrument panel lights
- Key start/stop system
- LCD operator display with soft key controls: engine speed, hour meter, gear/direction, battery voltage, hydraulic oil temperature, torque converter temperature, coolant temperature, trip totals (fuel and hours), lifetime totals (fuel and hours), operator settings (units, brightness, programmable hoe auxiliary flow), service mode diagnostics, oil life reset, DPF force regeneration, maintenance intervals, ECM/system info
- Loader, self-leveling, return-to-dig and transmission disconnect switch
- Loader, single tilt
- Mirror, interior, rearview
- Open circuit breather
- Power receptacle, 5 volt USB, 1 internal
- Power receptacle, 12 volt, 2 internal, 1 external
- Power steering, hydrostatic
- Product Link™, cellular, network manager
- Product Link, satellite, network manager
- Seat belt, retractable, 51 mm (2 in)
- Stabilizer shoes, street
- Steering column, fixed
- Steering knob
- Seat, air suspension, vinyl cover, with armrest
- Socket, two roof
- Starting system, glow plugs
- Steering, hydrostatic
- Storage compartment, lockable
- Storage tray
- Stop and tail lights
- Swing transport lock
- Tires
- Toolbox, external, lockable
- Torque converter
- Throttle, hand and foot, electronic
- Transmission, four speed, manual, syncromesh
- Transmission neutralizer switch
- Transport tie-downs
- Vandalism locks, three
- Warning horn, electric

OPTIONAL EQUIPMENT

- Auxiliary Hydraulics, rear, Adjustable Flow
- Battery, additional, 850 CCA
- Cab, standard
- Cold weather fuel (-30° C/-22° F)
- Cold weather package, including additional battery, engine block heater, radiator antifreeze (-50° C/-58° F), cold weather fuel (-30° C/-22° F) and mounting for an ether bottle
- Counterweights, 115 kg (255 lb), 240 kg (530 lb) or 460 kg (1,015 lb)
- Fenders, front with integral steps
- Guard, boom protection plate
- Guard, stabilizer, rock
- Hydraulic valves, loader (3rd valve for MP or Quick Coupler)
- Hydraulic valves, backhoe (5th and 6th function)
- Hydraulic lines, combined function auxiliary
- Joystick controls: pilot operated, excavator style with pattern changer
- LED lights, working (2 front, 2 rear)
- Pattern changer, in cab
- Quick Coupler, hydraulic, dual lock
- Quick Coupler, manual, dual lock
- Quick Coupler, manual, pin lock
- Radio and CD player, Bluetooth®
- Ride Control
- Rotating beacon, magnetic mount
- Seat, air suspension, fabric with armrest
- Seat belt, retractable, 75 mm (3 in)
- Security system, Bluetooth
- Security System, operator display
- Side mirrors, cab, external
- Single Tilt Loader Coupler, Integrated Tool Carrier (IT) Interface
- Stabilizer pads, grouser type
- Stabilizer pads, reversible
- Steering column, tilting
- Stick, extendible
- Vandalism protection, gauge cover
- Work Tool Attachments such as buckets, forks, material handling arms, augers, hammers, brooms, cold planers and vibratory plate compactors. See your Cat dealer for more information.

415 Backhoe Loader

For more complete information on Cat products, dealer services, and industry solutions, visit us on the web at www.cat.com

© 2023 Caterpillar
All rights reserved

Materials and specifications are subject to change without notice. Featured machines in photos may include additional equipment. See your Cat dealer for available options.

CAT, CATERPILLAR, LET'S DO THE WORK, their respective logos, "Caterpillar Corporate Yellow," the "Power Edge" and Cat "Modern Hex" trade dress as well as corporate and product identity used herein, are trademarks of Caterpillar and may not be used without permission.

AEHQ8241-02 (04-2023)
Replaces AEHQ8241-01
Build Number: 07A
(North America)

