



Cat[®] 299D3 XE Land Management

COMPACT TRACK LOADER
WITH STEEL TRACK UNDERCARRIAGE

FEATURES:

The Cat[®] 299D3 XE Land Management Compact Track Loader is a segment focused machine solution for customers involved in demanding vegetation-management applications, ranging from mulching, brush-cutting, vegetation control, and mowing. The standard suspended undercarriage combined with steel tracks provide superior traction, flotation, and stability to work in a wide range of applications and underfoot conditions.

The 299D3 XE Land Management machine's powerful Cat C3.8 engine combined with its high-flow/high-pressure auxiliary hydraulic system to deliver a calculated hydraulic power rating of 70 kW (94 hp), resulting in optimum performance when powering high-production, hydro-mechanical attachments. The 299D3 XE Land Management features the following:

- **Industry leading sealed and pressurized cab** provides a cleaner and quieter operating environment with excellent Work Tool visibility.
- **Available high-back, heated, air ride seat with seat mounted adjustable joystick controls** makes Cat Compact Track Loaders the industry leader in operator comfort.
- **High performance power train** provides maximum performance and production capability through the Electronic Torque Management system, and an electronic hand/foot throttle with decel pedal capability.
- **XE hydraulic system** provides high flow and high pressure that delivers industry leading hydraulic horsepower to efficiently run even the most power hungry work tools.
- **Extended working time** provided by large capacity external fuel tanks (220 L/58 gal – total).
- **Factory-equipped guarding and sealing** components to provide additional protection for areas that could be exposed to damage and to help reduce debris entry.
- **Standard fully independent torsion axle suspension** combined with the Speed Sensitive Ride Control system improves operation on rough terrain, enabling better load retention, increased productivity and greater operator comfort.
- **Maximize machine capability and control** with the standard Advanced Display providing on-screen adjustments for implement response, hystat response, and creep control, multi-language functionality with customizable layouts, security system, and rearview camera.
- **Ground level access** to all daily service and routine maintenance points helps reduce machine downtime for greater productivity.
- **Broad range of performance matched Cat Work Tool Attachments** make the Cat Compact Track Loader the most versatile machine on the job site.

Specifications

Engine

| | | |
|------------------------------------|----------------------|---------------------|
| Engine Model | Cat C3.8 DIT (turbo) | |
| Gross Power SAE J1995 | 82 kW | 110 hp |
| Net Power SAE 1349 | 79 kW | 106 hp |
| Net Power ISO 9249 | 80 kW | 107 hp |
| Peak Torque at 1,500 rpm SAE J1995 | 374 N-m | 276 lbf-ft |
| Displacement | 3.8 L | 232 in ³ |
| Stroke | 120 mm | 4.7 in |
| Bore | 100 mm | 3.9 in |

Weights*

| | | |
|------------------|---------|-----------|
| Operating Weight | 6188 kg | 13,613 lb |
|------------------|---------|-----------|

*Operating Weight, Operating Specifications and Dimensions all based on 75 kg (165 lb) operator, all fluids, single speed, ride control, enclosed cab with polycarbonate door, side windows, air conditioning, air ride seat, advanced display, rearview camera, 1,000 CCA battery, dual direction self level, 2036 mm (80 in) low profile bucket, 355 mm (14 in) steel tracks, and manual quick coupler.

Power Train

| | | |
|------------------------------------|----------|---------|
| Travel Speed (Forward or Reverse): | | |
| One Speed | 8.4 km/h | 5.2 mph |

Hydraulic System

| | | |
|-----------------------------------|------------|------------|
| Hydraulic Flow – XE: | | |
| Maximum Loader Hydraulic Pressure | 28 000 kPa | 4,061 psi |
| Maximum Loader Hydraulic Flow† | 150 L/min | 40 gal/min |
| Hydraulic Power (calculated) | 70 kW | 94 hp |
| Standard Flow Mode: | | |
| Loader Hydraulic Pressure | 23 000 kPa | 3,335 psi |
| Loader Hydraulic Flow | 86 L/min | 23 gal/min |
| Hydraulic Power (calculated) | 33 kW | 44 hp |

†When equipped with Cat 400 Series work tools.



299D3 XE Land Management Compact Track Loader

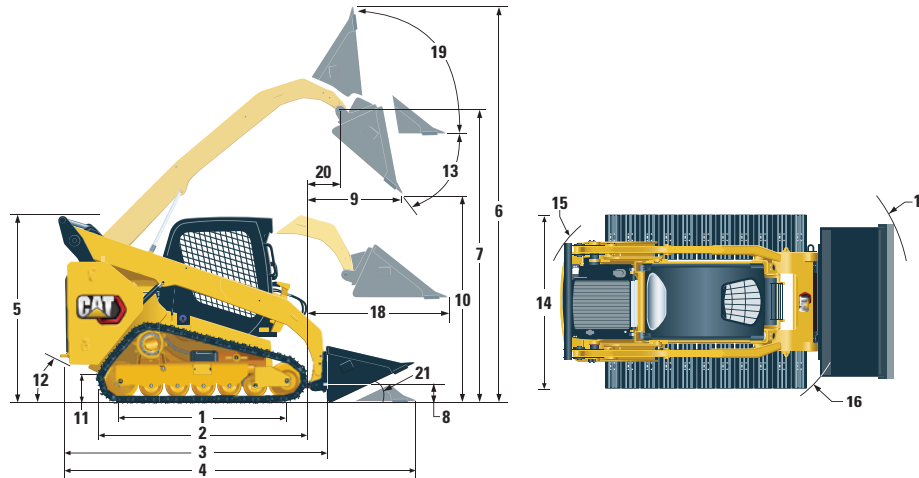

Dimensions*

| | mm | in | | mm | in |
|---------------------------------------|------|-------|---|------|------|
| 1 Length of Track on Ground | 1767 | 69.6 | 12 Departure Angle | | 33° |
| 2 Overall Length of Track | 2270 | 89.4 | 13 Maximum Dump Angle | | 54° |
| 3 Length without Bucket | 3189 | 125.5 | 14 Vehicle Width (355 mm/14 in steel tracks) | 1881 | 74.1 |
| 4 Length with Bucket on Ground | 3931 | 154.7 | 15 Turning Radius from Center – Machine Rear | 1881 | 74.0 |
| 5 Height to Top of Cab | 2125 | 83.6 | 16 Turning Radius from Center – Coupler | 1476 | 58.1 |
| 6 Maximum Overall Height | 4032 | 158.7 | 17 Turning Radius from Center – Bucket (racked) | 2314 | 91.1 |
| 7 Bucket Pin Height at Maximum Lift | 3208 | 126.3 | 18 Maximum Reach with Arms Parallel to Ground | 1319 | 51.9 |
| 8 Bucket Pin Height at Carry Position | 180 | 7.1 | 19 Rack Back Angle at Maximum Height | | 81° |
| 9 Reach at Maximum Lift and Dump | 852 | 33.6 | 20 Bucket Pin Reach at Maximum Lift | 493 | 19.4 |
| 10 Clearance at Maximum Lift and Dump | 2399 | 94.5 | 21 Roll Back Angle | | 25° |
| 11 Ground Clearance | 245 | 9.6 | | | |

Operating Specifications*

| | | |
|--|---------------------|-----------------------|
| Rated Operating Capacity: | | |
| 35% Tipping Load | 2195 kg | 4,830 lb |
| 50% Tipping Load | 3135 kg | 6,900 lb |
| Tipping Load | 6275 kg | 13,800 lb |
| Breakout Force, Tilt Cylinder | 3298 kg | 7,270 lb |
| Breakout Force, Lift Cylinder | 2795 kg | 6,162 lb |
| Ground Contact Area (355 mm/14 in track) | 1.23 m ² | 1,914 in ² |
| Ground Pressure (355 mm/14 in track) | 49.1 kPa | 7.1 psi |

Cab

| | |
|------|-----------------------|
| ROPS | ISO 3471:2008 |
| FOPS | ISO 3449:2005 Level I |

Service Refill Capacities

| | | |
|---------------------------------|-------|----------|
| Cooling System | 16 L | 4.1 gal |
| Diesel Exhaust Fluid (DEF) Tank | 19 L | 5 gal |
| Engine Crankcase | 13 L | 3.5 gal |
| Fuel Tank | 220 L | 58 gal |
| Hydraulic System | 55 L | 14.5 gal |
| Hydraulic Tank | 39 L | 10.3 gal |

Noise Level

| | |
|----------------|-----------|
| Inside Cab** | 83 dB(A) |
| Outside Cab*** | 104 dB(A) |

- Sealed and pressurized cab is standard in North America and Europe.
- **The declared dynamic operator sound pressure levels per ISO 6396:2008. The measurements were conducted with the cab doors and windows closed and at 70% of the maximum engine cooling fan speed. The sound level may vary at different engine cooling fan speeds.
- ***The labeled sound power level for the CE marked configurations when measured according to the test procedure and conditions specified in 2000/14/EC.

Air Conditioning System (if equipped)

The air conditioning system on this machine contains the fluorinated greenhouse gas refrigerant R134a (Global Warming Potential = 1430). The system contains 0.81 kg of refrigerant which has a CO₂ equivalent of 1.158 metric tonnes.

299D3 XE Land Management Compact Track Loader

MANDATORY EQUIPMENT

- Quick Coupler, Mechanical
- High Visibility Seat Belt, 50 mm (2 in) or 75 mm (3 in)

PERFORMANCE PACKAGE

- Performance Package H3: *XE Hydraulics, Dual Direction Electronic Self Level (Raise and Lower), Work Tool Return to Dig, Work Tool Positioner, and Electronic Snubbing (Raise and Lower)*

STANDARD EQUIPMENT

ELECTRICAL

- 12 volt Electrical System
- 100 ampere Alternator
- Ignition Key Start/Stop Switch
- Lights: *Gauge Backlighting, Two Rear Tail Lights, Two Rear LED Working Lights, Two Adjustable Front LED Lights, Dome Light*
- Backup Alarm
- Heavy Duty Battery, 1,000 CCA, with Battery Disconnect

OPERATOR ENVIRONMENT

- Gauges: *Fuel Level, DEF Level, Hour Meter*
- Operator Warning System Indicators: *Air Filter Restriction, Alternator Output, Armrest Raised/Operator Out of Seat, Engine Coolant Temperature, Engine Oil Pressure, Air Inlet Heater Activation, Hydraulic Filter Restriction, Hydraulic Oil Temperature, Park Brake Engaged, Engine Emission System*
- High Back Cloth Seat with Air Suspension, Heated with Recline and Lumbar Support and Fully Adjustable Seat Mounted Controls
- Fold In Ergonomic Contoured Armrest
- Control Interlock System, when operator leaves seat or armrest raised: *Hydraulic System Disables, Hydrostatic Transmission Disables, Parking Brake Engages*
- ROPS Cab, Enclosed, Tilt Up
- FOPS, Level I
- Top, Rear and Side Windows
- Headliner, Deluxe
- Floor Mat
- Interior Rearview Mirror
- USB Charging Port
- Horn
- Hand (Dial) and Foot Throttle, Electronic with Decel Feature
- Advanced Display with Rearview Camera: *Full Color, 127 mm (5 in) LCD screen; Advanced Multi-operator Security System; On-screen Adjustments for Implement Response, Hystat Response and Creep Control*
- Storage Compartment with Netting

COMFORT PACKAGE

- Enclosed ROPS with A/C (C3): *Foot Throttle, Headliner, Heater and Defroster, Side Windows, Cup Holder, Radio Ready, Air Ride Seat (High Back and Heated) and Polycarbonate Door*

POWER TRAIN

- Cat C3.8, Turbo Diesel Engine, Meeting U.S. EPA Tier 4 Final and EU Stage IV Emission Standards
- Air Cleaner, Dual Element, Radial Seal
- S-O-SSM Sampling Valve, Hydraulic Oil
- Filter, Cartridge-type, Hydraulic
- Filter, Canister-type, Fuel and Water Separator
- Radiator/Hydraulic Oil Cooler (side-by-side)
- Spring Applied, Hydraulically Released, Wet Multi Disc Parking Brakes
- Hydrostatic Transmission, Single Speed Travel
- Suspension – Independent Torsion Axles (4)
- Speed Sensitive Ride Control

OTHER

- Engine Enclosure, Lockable
- Extended Life Antifreeze, –37° C (–34° F)
- Machine Tie Down Points (6)
- Support, Lift Arm
- Hydraulic Oil Level Sight Gauge
- Radiator Coolant Level Sight Gauge
- Radiator, Expansion Bottle
- Cat ToughGuardTM Hose
- Auxiliary, Hydraulics, Continuous Flow
- Split D-Ring to Route Work Tool Hoses Along Side of Left Lift Arm
- Electrical Outlet, Beacon
- Belly and Engine Compartment Access Panels for Cleanout
- Variable Speed Demand Fan with Reversing Functionality
- Steel Track (Sealed and Lubricated – SALT) – 355 mm (14.0 in) with Triple Grouser Track Shoes
- Product LinkTM PL240, Cellular
- Fire Extinguisher Mounting Bracket (in-cab)
- Screw-to-Connect Auxiliary Hydraulic Couplings (¾ in)
- Push-to-Connect Flat Faced Auxiliary Hydraulic Couplings (½ in)
- Debris Guarding (external and turbo)
- Precleaner for Engine Air Intake
- Additional Machine Guarding
- Drive-line Guarding
- Turbo Guard
- Additional Machine Sealing

299D3 XE Land Management Compact Track Loader

OPTIONAL ATTACHMENTS

- Beacon, Rotating
- Engine Block Heater – 120V
- Oil, Hydraulic, Cold Operation
- Paint, Custom
- Product Link PL641, Cellular
- Bluetooth® Radio with Microphone (AM/FM/Weather Band Receiver with USB and Auxiliary Input Jack)
- Roof Mounted Auxiliary Hydraulic Cooler

For more complete information on Cat products, dealer services, and industry solutions, visit us on the web at www.cat.com

© 2019 Caterpillar
All rights reserved

Materials and specifications are subject to change without notice. Featured machines in photos may include additional equipment. See your Cat dealer for available options.

CAT, CATERPILLAR, LET'S DO THE WORK, their respective logos, "Caterpillar Yellow," the "Power Edge" and Cat "Modern Hex" trade dress as well as corporate and product identity used herein, are trademarks of Caterpillar and may not be used without permission.

AEHQ8253 (12-2019)
(Am North, ANZP)

