



Cat[®] CP56B

Padfoot Drum Vibratory Soil Compactor

The Cat[®] CP56B features a padfoot drum and is ideally suited for cohesive and semi-cohesive soil applications.

Comfortable and Ergonomic Operator Station

- Features pivoting seat with integrated multifunction LCD display and control console.
- Outstanding visibility to the front and rear of machine
- Low sound levels and vibration for greater operator comfort and productivity.

Exceptional Propel System

- Built around the exclusive Cat dual pump propel system, two pumps provide separate dedicated flow to drum drive motor and rear axle motor for exceptional gradeability and traction in forward and reverse.
- Electronic propel control provides more precise machine control.

Virtually Maintenance Free

- Maintenance-free hitch bearings.
- Extended maintenance intervals for vibratory system and hydraulic system, providing more uptime and lower maintenance costs.

Enhanced Compaction Performance

- More weight at the drum and greater amplitude.
- Automated speed control and vibratory system functions make it easy to ensure consistent, high quality compaction.

Cat Compaction Control - Machine Drive Power (MDP)

- Helps operator determine when compaction has been completed to specification for greater productivity and uniform compaction quality.

VIBRATORY SOIL COMPACTOR SELECTION GUIDE

Assumes density specification is 95% of Standard Proctor and can vary substantially due to different soil conditions.

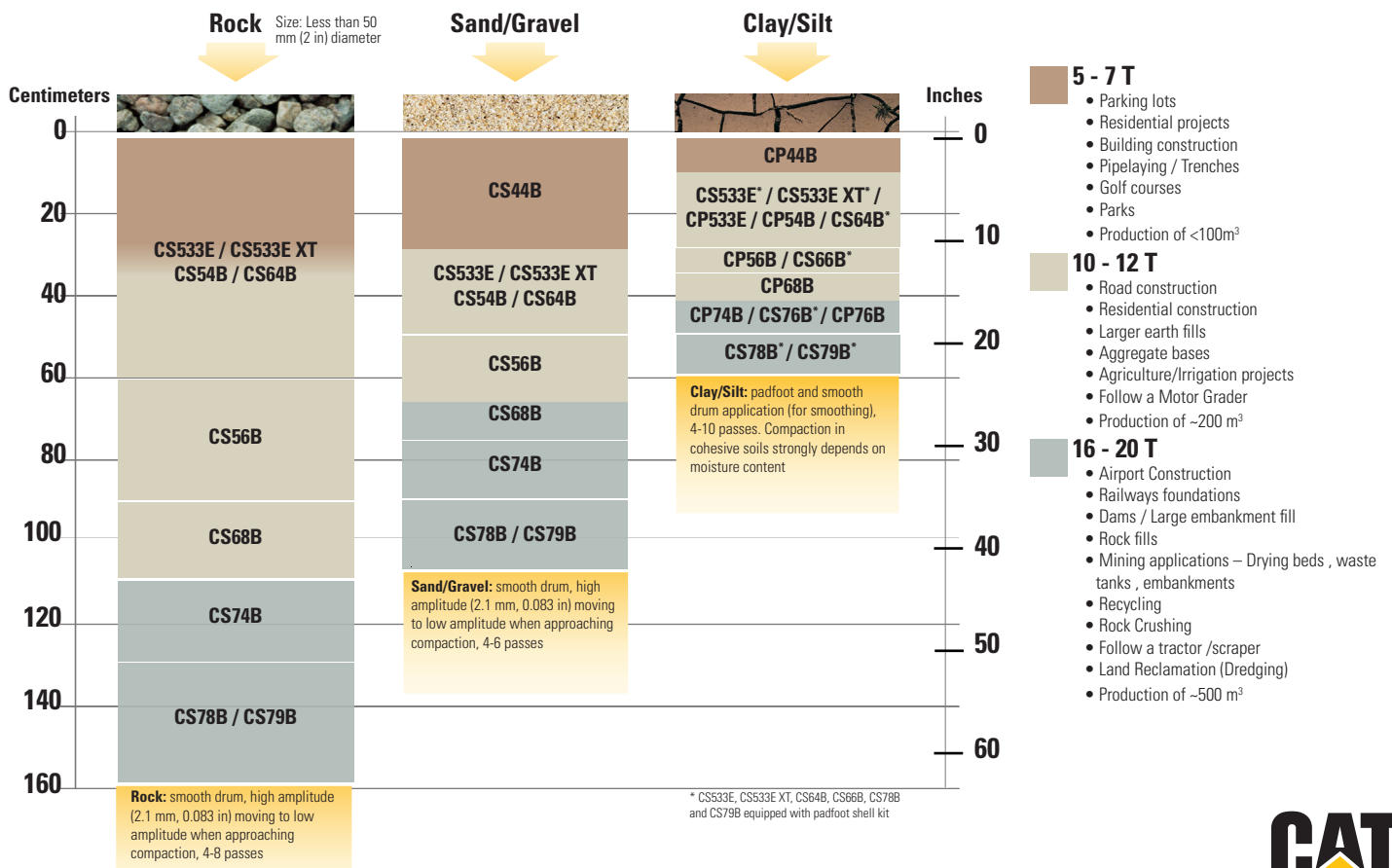

Cat® CP56B Padfoot Drum Vibratory Soil Compactor

Technical Specifications

Engine - Power Train

Engine Model	Cat C7.1	
Global Emissions	US EPA Tier 3 EU Stage IIIA	
Gross Power ISO 14396	116.5 kW	156 hp
Displacement	7.01 L	428 in ³
Stroke	135 mm	5.31 in
Bore	105 mm	4.1 in
Max. Travel Speed (Forward or Reverse)	11.4 km/h	7 mph
Theoretical Gradeability, no vibration*	57%	

Weights

Operating Weight w/ open platform	11 140 kg	24,560 lb
Operating Weight w/ steel sun canopy	11 235 kg	24,769 lb
Operating Weight w/ ROPS/FOPS canopy	11 400 kg	25,133 lb
Operating Weight w/ ROPS/FOPS cab	11 725 kg	25,849 lb
Weight at Drum w/ open platform	6240 kg	13,757 lb
Weight at Drum w/ steel sun canopy	6275 kg	13,834 lb
Weight at Drum w/ ROPS/FOPS canopy	6330 kg	13,955 lb
Weight at Drum w/ ROPS/FOPS cab	6465 kg	14,253 lb
Additional Weight w/ Leveling Blade	+ 620 kg	+ 1,373 lb

Vibratory System Specifications

Frequency		
Standard	30.5 Hz	1830 vpm
During Eco-mode Operation	27.7 Hz	1664 vpm
Optional Variable Frequency	23.3-30.5 Hz	1400-1830 vpm
Nominal Amplitude @ 30.5 Hz (1830 vpm)		
High	2.1 mm	0.083 in
Low	0.98 mm	0.039 in
Centrifugal Force @ 30.5 Hz (1830 vpm)		
Maximum	301 kN	67,600 lb
Minimum	141 kN	31,670 lb

Service Refill Capacities

Fuel Tank, total capacity	242 L	64 gal
Cooling System	27.9 L	7.4 gal
Engine Oil w/ Filter	17.4 L	4.6 gal
Eccentric Weight Housings (Combined)	26 L	6.9 gal
Axle and Final Drives	18 L	4.8 gal
Hydraulic Tank (service refill)	50 L	13.2 gal

* Actual gradeability may vary based on site conditions and machine configuration. Refer to the Operation and Maintenance Manual for more information.

Cat® CP56B Padfoot Drum Vibratory Soil Compactor

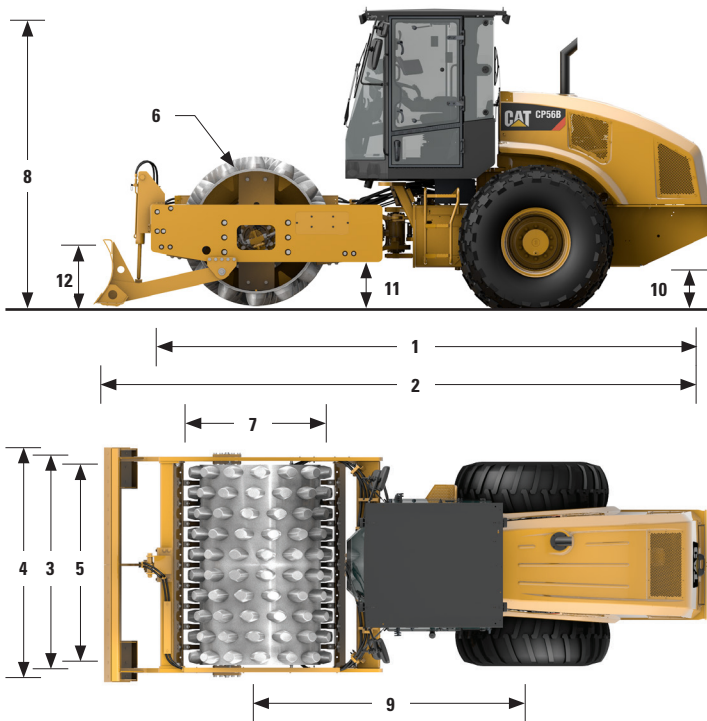

Dimensions

1	Overall Length	5.86 m	19.2 ft
2	Overall Length w/ optional Leveling Blade	6.4 m	20.9 ft
3	Overall Width	2.30 m	7.53 ft
4	Overall Width w/optional Leveling Blade	2.5 m	8.25 ft
5	Drum Width	2134 mm	84 in
6	Drum Shell Thickness	30 mm	1.18 in
7	Drum Diameter (over pads)	1534 mm	60.4 in
8	Maximum Overall Height	3.11 m	10.2 ft
9	Wheelbase	2.9 m	9.5 ft
10	Ground Clearance	442 mm	17.4 in
11	Curb Clearance	494 mm	19.3 in
12	Optional Leveling Blade Height	688 mm	27.1 in
	Inside Turning Radius	3.68 m	12.07 ft
	Hitch Articulation Angle	34°	
	Hitch Oscillation Angle	15°	

Padfoot Specifications

	Number of Pads	140	
	Pad Height, oval pads	127 mm	5 in
	Pad Face Area, oval pads	74.4 cm ²	11.5 in ²
	Pad Height, optional square pads	100 mm	3.9 in
	Pad Face Area, optional square pads	123 cm ²	19.1 in ²
	Number of Chevrons	14	

Cat® CP56B Smooth Drum Vibratory Soil Compactor

Standard and Optional Equipment

Standard and optional equipment may vary. Consult your Cat dealer for details.

	Standard	Optional
OPERATOR ENVIRONMENT		
Open Platform with Handrails/Guardrails, Floor Mat	✓	
Vinyl Adjustable Pivoting Seat with Integrated Console and LCD Display	✓	
Adjustable Tilting Steering Column with Integrated Cup Holders	✓	
Seat Belt	✓	
12-volt Power Outlet	✓	
Horn, Backup Alarm	✓	
Steel Sun Canopy		✓
ROPS/FOPS Canopy		✓
ROPS/FOPS Cab with Climate Control		✓
Internal Rear View Mirror		✓
External Rear View Mirrors		✓
Sun Visor		✓
Cab Internal Roll-down Sun Screen		✓
VIBRATORY SYSTEM		
Padfoot Drum	✓	
Dual Amplitude, Single Frequency	✓	
Dual Pod-Style Eccentric Weight Housings	✓	
Auto-vibe Function	✓	
Dual Adjustable Steel Scrapers	✓	
Leveling Blade		✓
Variable Frequency		✓

	Standard	Optional
POWER TRAIN		
Cat C7.1 Diesel Engine	✓	
Air Cleaner, Dual Element	✓	
Three-Speed Throttle Switch, Eco-mode and Automatic Speed Control	✓	
Dual Propel Pumps; One for Drum Drive, One for Rear Axle	✓	
Fuel Filter, Water Separator, Priming Pump, Water Indicator	✓	
Tilting Radiator/Hydraulic Oil Cooler	✓	
Dual Braking System	✓	
Two-speed Hydrostatic Transmission	✓	
Transmission Guard		✓
CAT COMPACTION CONTROL TECHNOLOGY		
Measure - Machine Drive Power		✓
Map - SBAS GNSS Mapping		✓
Connect - Machine to Machine Communication		✓
ELECTRICAL		
24 volt Electrical System	✓	
100 ampere Alternator	✓	
750 Cold-cranking Amps Battery Capacity	✓	
OTHER		
Product Link™	✓	
Sight Gauges for Hydraulic Oil Level and Radiator Coolant Level	✓	
S-O-S SM Sampling Valves: Engine Oil, Hydraulic Oil and Coolant	✓	
Upgraded Halogen Light Package		✓
Rotating Beacon		✓
Fuel Fill Access Door		✓
Containerized Shipping		✓



For more complete information on Cat products, dealer services, and industry solutions, visit us on the web at www.cat.com

© 2019 Caterpillar
All rights reserved

Materials and specifications are subject to change without notice. Featured machines in photos may include additional equipment. See your Cat dealer for available options.

CAT, CATERPILLAR, LET'S DO THE WORK, their respective logos, "Caterpillar Yellow," the "Power Edge" and Cat "Modern Hex" trade dress as well as corporate and product identity used herein, are trademarks of Caterpillar and may not be used without permission.

VisionLink is a trademark of Trimble Navigation Limited, registered in the United States and in other countries.

QEHQ2461-01 (09-2019)
Replaces QEHQ1654-04
LRC

