

Introduction

This document provides instructions for installing an accessory on a Cat® Utility Vehicle (CUV). Do not perform any procedure in this document until you have read and understood the information contained in this document and the Operation and Maintenance Manual.

Safety Section

<p>⚠ WARNING</p> <p>Do not operate or work on this product unless you have read and understood the instruction and warnings in the relevant Operation and Maintenance Manuals and relevant service literature. Failure to follow the instructions or heed the warnings could result in injury or death. Proper care is your responsibility.</p>	<p>⚠ WARNING</p> <p>Personal injury can result from improper handling of chemicals. Make sure you use all the necessary protective equipment required to do the job. Make sure that you read and understand all directions and hazards described on the labels and material safety data sheet of any chemical that is used. Observe all safety precautions recommended by the chemical manufacturer for handling, storage, and disposal of chemicals.</p>
<p>⚠ WARNING</p> <p>Failure to follow all safety guidelines prescribed in this document and by governing authorities and regulatory agencies may result in severe injury or death of personnel or machine damage.</p>	<p>⚠ WARNING</p> <p>Before servicing/performing maintenance on the machine, electrical power must be physically disconnected; battery cables must be disconnected from the battery. All applicable lock out and tag out procedures must be followed.</p>
<p>⚠ WARNING</p> <p>When removing a major component or attachment, ensure that it is properly blocked or secured before removing mounting hardware. An assembly that is disconnected without proper blocking may shift or fall, resulting in serious injury or death of personnel or machine damage.</p>	<p>⚠ WARNING</p> <p>Observe the safe working load limits of all lifting and blocking devices and keep a safe distance from suspended/blocked loads. Personnel may be seriously injured or killed by falling loads.</p>
<p>⚠ WARNING</p> <p>Personal injury or death can result from improper maintenance procedures. To avoid injury or death, follow the procedures exactly as stated below.</p>	<p>⚠ WARNING</p> <p>Do not operate the machine if any guards or covers are missing or inadequately secured. Personnel could be seriously injured or machine damage may occur.</p>

Caterpillar®

Installation Instructions - Accessory Kit

Rear Bumper Kit

(p/n 580-2493)



■ **NOTE:** Read these Installation Instructions thoroughly before beginning the installation process. Retain these Installation Instructions for future reference.

Kit includes:

Ref. No.	QTY	DESCRIPTION
1	14	Cap Screw (M8 x 25 mm)
2	4	Carriage Bolt (M8 x 20 mm)
3	4	Nylon Flange Nut (M 8)
4	1	Center Bumper
5	1	Right-Side Corner Bumper
6	1	Left-Side Corner Bumper
7	1	Right-Side Reinforcement Plate
8	1	Left-Side Reinforcement Plate
9	1	Right-Side Reinforcement Plate
10	1	Left-Side Reinforcement Plate
11	2	Mounting Bracket

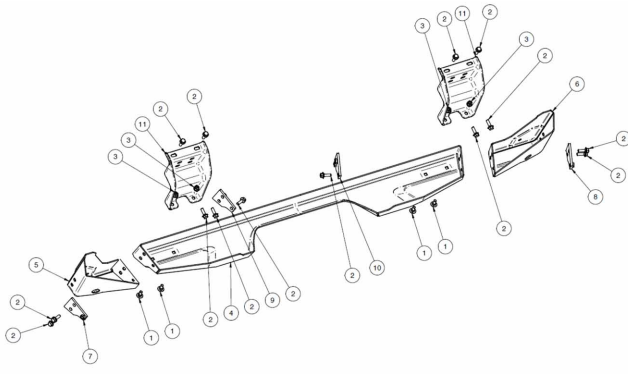

Tools Required:

- 13 mm Socket/Wrench
- Ratchet Wrench

1. Position both Mounting Brackets with the mounting locations on the bottom side of the cargo box; then loosely secure using eight Cap Screws (M8 x 25 mm). See Fig. 1.

Fig. 1

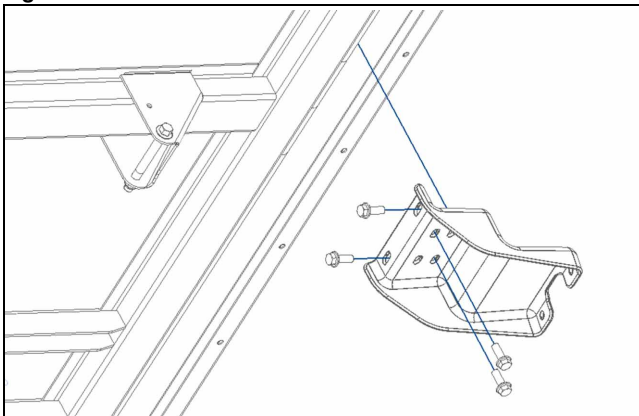

VOR-376

2. Position Left-Side Corner Bumper with the holes in Center Bumper and secure using three cap screws (M8 x 25 mm), and both Left-Side Reinforcement Plates. Tighten securely. See Fig. 2.

Fig. 2

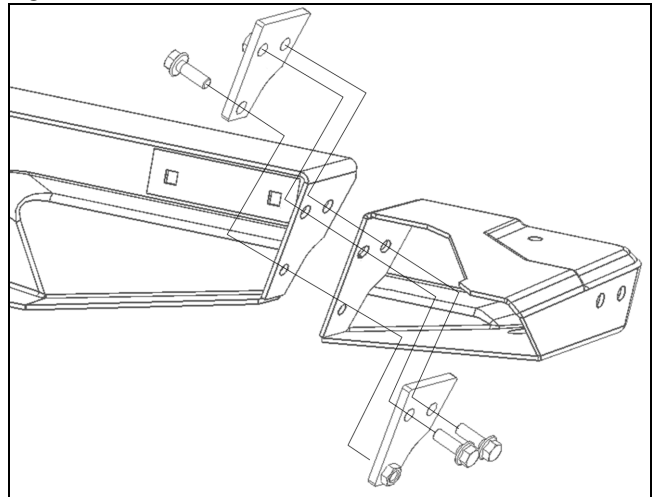

VOR-355

3. Repeat for opposite side.

4. Loosely secure Bumper to the mounting brackets using four Carriage Bolts (M8 x 20 mm) and four M8 nylon flange nuts. See Fig. 3.

Fig. 3

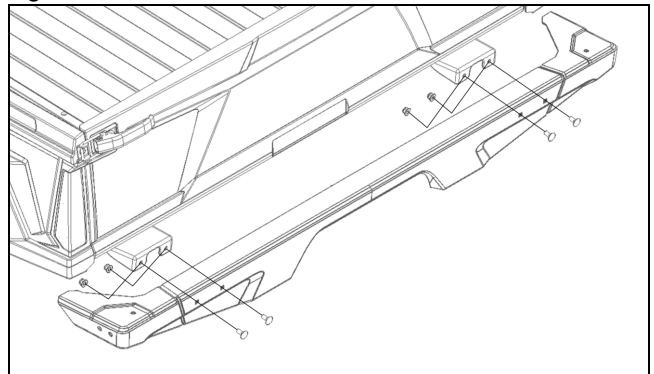

VOR-354

5. With the center bumper aligned with the vehicle, tighten all hardware securely.