



Cat[®] CS56B

Smooth Drum Vibratory Soil Compactor

The Cat[®] CS56B features a smooth drum and is ideally suited for granular soil applications or cohesive soil applications with the use of an optional padfoot shell kit.

Comfortable and Ergonomic Operator Station

- Features pivoting seat with integrated multifunction LCD display and control console.
- Outstanding visibility to the front and rear of machine
- Low sound levels and vibration for greater operator comfort and productivity.

Exceptional Propel System

- Built around the exclusive Cat dual pump propel system, two pumps provide separate dedicated flow to drum drive motor and rear axle motor for exceptional gradeability and traction in forward and reverse.
- Electronic propel control provides more precise machine control.

Virtually Maintenance Free

- Maintenance-free hitch bearings.
- Extended maintenance intervals for vibratory system and hydraulic system, providing more uptime and lower maintenance costs.

Enhanced Compaction Performance

- More weight at the drum and greater amplitude.
- Automated speed control and vibratory system functions make it easy to ensure consistent, high quality compaction.

Cat Compaction Control

- Helps operator determine when compaction has been completed to specification for greater productivity and uniform compaction quality.
- Accelerometer-based (CMV) and exclusive Machine Drive Power (MDP) measurement technologies available.

VIBRATORY SOIL COMPACTOR SELECTION GUIDE

Assumes density specification is 95% of Standard Proctor and can vary substantially due to different soil conditions.

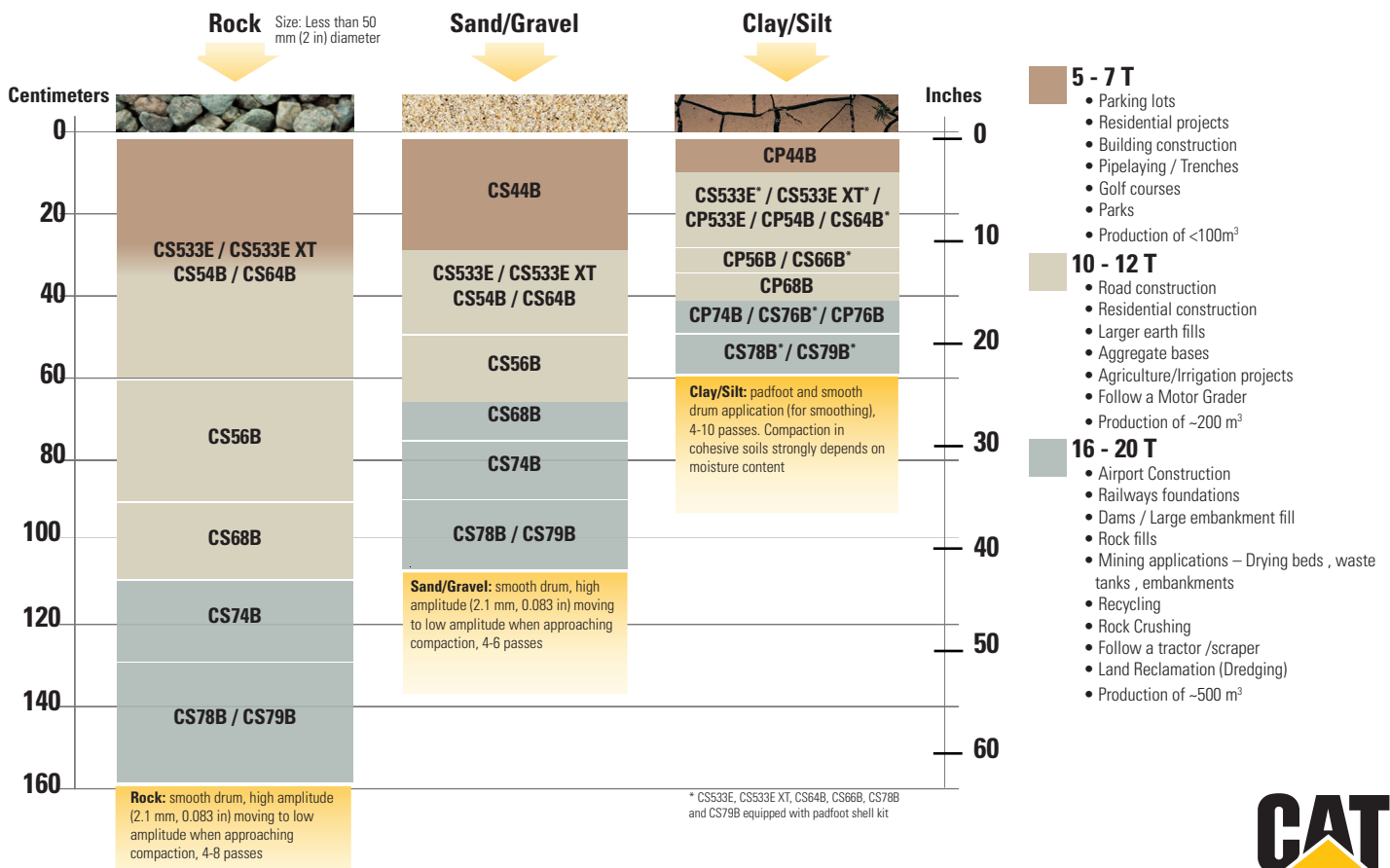

Cat® CS56B Smooth Drum Vibratory Soil Compactor

Technical Specifications

Engine - Power Train

Engine Model	Cat C7.1	
Global Emissions	US EPA Tier 3 EU Stage IIIA	
Gross Power ISO 14396	116.1 kW	155.7 hp
Displacement	7.01 L	428 in ³
Stroke	135 mm	5.31 in
Bore	105 mm	4.1 in
Max. Travel Speed (Forward or Reverse)	11.4 km/h	7 mph
Theoretical Gradeability, no vibration*	57%	

Weights

Operating Weight w/ open platform	10 970 kg	24,185 lb
Operating Weight w/ steel sun canopy	11 065 kg	24,394 lb
Operating Weight w/ ROPS/FOPS canopy	11 235 kg	24,769 lb
Operating Weight w/ ROPS/FOPS cab	11 555 kg	25,474 lb
Weight at Drum w/ open platform	6135 kg	13,525 lb
Weight at Drum w/ steel sun canopy	6165 kg	13,592 lb
Weight at Drum w/ ROPS/FOPS canopy	6220 kg	13,713 lb
Weight at Drum w/ ROPS/FOPS cab	6355 kg	14,010 lb
Additional Weight with		
Oval Padfoot Shell Kit	+ 1730 kg	+ 3,814 lb
Square Padfoot Shell Kit	+ 1880 kg	+ 4,145 lb
Leveling Blade	+ 620 kg	+ 1,373 lb

Vibratory System Specifications

Frequency		
Standard	30.5 Hz	1830 vpm
During Eco-mode Operation	27.7 Hz	1664 vpm
Optional Variable Frequency	23.3-30.5 Hz	1400-1830 vpm
Nominal Amplitude @ 30.5 Hz (1830 vpm)		
High	2.1 mm	0.083 in
Low	0.98 mm	0.039 in
Centrifugal Force @ 30.5 Hz (1830 vpm)		
Maximum	301 kN	67,600 lb
Minimum	141 kN	31,670 lb
Static Linear Load		
w/ open platform	28.7 kg/cm	161 lbs/in
w/ steel sun canopy	28.9 kg/cm	161.8 lbs/in
w/ ROPS/FOPS canopy	29.1 kg/cm	163.3 lbs/in
w/ ROPS/FOPS cab	29.8 kg/cm	166.8 lbs/in

Service Refill Capacities

Fuel Tank, total capacity	242 L	64 gal
Cooling System	27.9 L	7.4 gal
Engine Oil w/ Filter	17.4 L	4.6 gal
Eccentric Weight Housings (Combined)	26 L	6.9 gal
Axle and Final Drives	18 L	4.8 gal
Hydraulic Tank (service refill)	50 L	13.2 gal

* Actual gradeability may vary based on site conditions and machine configuration. Refer to the Operation and Maintenance Manual for more information.

Cat® CS56B Smooth Drum Vibratory Soil Compactor

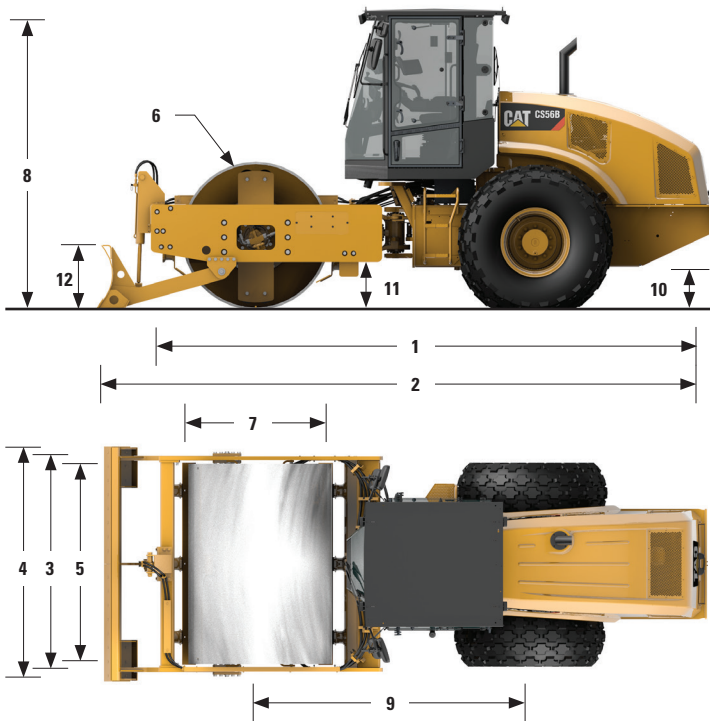

Dimensions

1	Overall Length	5.86 m	19.2 ft
2	Overall Length w/ optional Leveling Blade	6.4 m	20.9 ft
3	Overall Width	2.30 m	7.53 ft
4	Overall Width w/optional Leveling Blade	2.5 m	8.25 ft
5	Drum Width	2134 mm	84 in
6	Drum Shell Thickness	30 mm	1.18 in
7	Drum Diameter	1534 mm	60.4 in
8	Overall Height	3.11 m	10.2 ft
9	Wheelbase	2.9 m	9.5 ft
10	Ground Clearance	442 mm	17.4 in
11	Curb Clearance	494 mm	19.3 in
12	Optional Leveling Blade Height	688 mm	27.1 in
	Inside Turning Radius	3.68 m	12.07 ft
	Hitch Articulation Angle	34°	
	Hitch Oscillation Angle	15°	

Optional Padfoot Shell Kit Specifications

Number of Pads	120	
Pad Height, oval pads	90 mm	3.5 in
Pad Face Area, oval pads	63.5 cm ²	9.8 in ²
Pad Height, optional square pads	90 mm	3.5 in
Pad Face Area, optional square pads	123 cm ²	19.1 in ²
Number of Chevrons	16	

Cat® CS56B Smooth Drum Vibratory Soil Compactor

Standard and Optional Equipment

Standard and optional equipment may vary. Consult your Cat dealer for details.

	Standard	Optional		Standard	Optional
OPERATOR ENVIRONMENT			POWER TRAIN		
Open Platform with Handrails/Guardrails, Floor Mat	✓		Cat C7.1 Diesel Engine	✓	
Vinyl Adjustable Pivoting Seat with Integrated Console and LCD Display	✓		Air Cleaner, Dual Element	✓	
Adjustable Tilting Steering Column with Integrated Cup Holders	✓		Three-Speed Throttle Switch, Eco-mode and Automatic Speed Control	✓	
Seat Belt	✓		Dual Propel Pumps; One for Drum Drive, One for Rear Axle	✓	
12-volt Power Outlet	✓		Fuel Filter, Water Separator, Priming Pump, Water Indicator	✓	
Horn, Backup Alarm	✓		Tilting Radiator/Hydraulic Oil Cooler	✓	
Steel Sun Canopy		✓	Dual Braking System	✓	
ROPS/FOPS Canopy		✓	Two-speed Hydrostatic Transmission	✓	
ROPS/FOPS Cab with Climate Control		✓	Transmission Guard		✓
Internal Rear View Mirror		✓	CAT COMPACTION CONTROL TECHNOLOGY		
External Rear View Mirrors		✓	Measure - Machine Drive Power and/or CMV		✓
Sun Visor		✓	Map - SBAS GNSS Mapping		✓
Cab Internal Roll-down Sun Screen		✓	Connect - Machine to Machine Communication		✓
VIBRATORY SYSTEM			ELECTRICAL		
Smooth Drum	✓		24 volt Electrical System	✓	
Dual Amplitude, Single Frequency	✓		100 ampere Alternator	✓	
Dual Pod-Style Eccentric Weight Housings	✓		750 Cold-cranking Amps Battery Capacity	✓	
Auto-vibe Function	✓		OTHER		
Front Adjustable Steel Scraper	✓		Product Link™	✓	
Padfoot Shell Kit (oval or square pads available)		✓	Sight Gauges for Hydraulic Oil Level and Radiator Coolant Level	✓	
Leveling Blade		✓	S-O-S SM Sampling Valves: Engine Oil, Hydraulic Oil and Coolant	✓	
Variable Frequency		✓	Upgraded Halogen Light Package		✓
Dual Adjustable Steel Scrapers		✓	Rotating Beacon		✓
Dual Adjustable Polyurethane Scrapers		✓	Fuel Fill Access Door		✓
			Containerized Shipping		✓

For more complete information on Cat products, dealer services, and industry solutions, visit us on the web at www.cat.com

© 2019 Caterpillar
All rights reserved

Materials and specifications are subject to change without notice. Featured machines in photos may include additional equipment. See your Cat dealer for available options.

CAT, CATERPILLAR, LET'S DO THE WORK, their respective logos, "Caterpillar Yellow," the "Power Edge" and Cat "Modern Hex" trade dress as well as corporate and product identity used herein, are trademarks of Caterpillar and may not be used without permission.

VisionLink is a trademark of Trimble Navigation Limited, registered in the United States and in other countries.

QEHQ2464 (09-2019)
Replaces QEHQ1653
LRC

