

INV1250 Inverter Generator

CO (501-5453), Non-CO (530-1273)



1000 W Running | 1250 W Starting

Features

- Quiet running: meets National Park Service campground requirements
- At only 33 lbs, this lightweight inverter generator can go anywhere
- DOUBLE+ your power by paralleling with another INV1250 or INV2000¹
- A single tank of fuel will last you nearly 8 hours at 50% load
- Clean, regulated A/C power for sensitive electronics (< 3% THD)
- 2x USB Ports, including a 2.1 Amp port for charging your tablet



Because of continuing improvements, actual product may differ slightly from this photo.

Control Panel



¹Requires 2nd unit and Parallel Kit (530-1202)

²CO Model

³Non-CO Model

INV1250 Inverter Generator

CO (501-5453), Non-CO (530-1273)



Specifications

| ENGINE | |
|----------------------------|---|
| Starting Method | Pull |
| Run Time @ 50% Load | 7.9 hours |
| Idle Control | Engine Smart Control (ESC) |
| Fuel Tank Nominal Capacity | 0.8 gal / 3 L |
| Fuel Tank Material | Plastic |
| Fuel Type | Unleaded Gasoline \geq 86 octane ¹ |
| Fuel Gauge | - |
| Engine Displacement | 60 cc |
| Engine Type | OHV |
| Engine Speed | Variable RPM |
| Lubrication Method | Splash |
| Recommended Oil | SAE 30 or 10W-30 |
| Oil Capacity | 0.33 qt / 0.31 L |
| Region Certifications | CO: EPA & CARB Non-CO: EPA, CARB, CSA |
| Shutdown Method | Automatic Low Oil Level |

| ELECTRICAL | |
|---------------------------------|--|
| Running Power | 1000 Watts |
| Starting Power | 1250 Watts |
| AC Output | 120V @ 60 Hz |
| DC Output | 5V (2.1A) |
| Total Harmonic Distortion (THD) | < 3% |
| Receptacles | (1) 5V 2.1A USB, (1) 5V 1.0A USB CO: (1) 5-20R Outlet Non-CO: (1) 5-20R Duplex |
| Voltage Regulation | Inverter Type |
| Battery Type | - |

| EXTRA FEATURES | |
|---------------------------|--------------------------------|
| Illuminated Control Panel | Yes |
| Carbon Monoxide Shutdown | Yes ² |
| Handle Style | Integrated |
| Wheel Type | - |
| Indicator Lights | Low Oil, Overload, and Running |
| USB | (1) 2.1A 5V and (1) 1.0A 5V |

WARRANTY Standard 2-year limited, extended 3-year limited when registered within 30 days at cat.com/homeandoutdoorpower-warranty

¹ No more than 10% ethanol; fuel stabilizer should also be used for storage ² Only on CO Model

Dimensions and Weights

| ASSEMBLED | |
|-------------------|------------------|
| Height | 16.6 in / 421 mm |
| Width | 11.5 in / 293 mm |
| Length | 18.3 in / 466 mm |
| Extended Length | - |
| Unit Weight (Dry) | 33.1 lbs / 15 kg |

| CARTON | |
|-----------------|--------------------|
| Height | 18.1 in / 460 mm |
| Width | 14.4 in / 365 mm |
| Length | 21.1 in / 535 mm |
| Shipping Weight | 38.6 lbs / 17.5 kg |

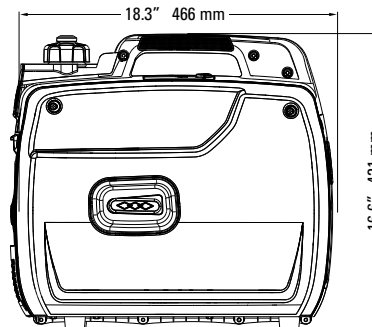
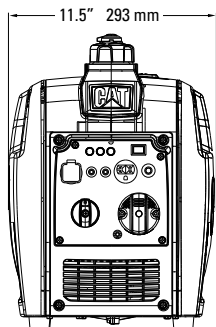

CATERPILLAR®

© 2020 Caterpillar. All Rights Reserved. CAT, CATERPILLAR, LET'S DO THE WORK their respective logos, "Caterpillar Yellow," the "Power Edge" and "Modern Hex" trade dress, as well as corporate and product identity used herein, are trademarks of Caterpillar and may not be used without permission.



For more information:
cat.com/homeandoutdoorpower

Accessories

30 Amp Inverter Parallel Kit (530-1202)



Small Inverter Protective Cover
(517-9207)



LEHQ0067-00