

INV4000 E Inverter Generator

CO (501-5454) / Non-CO (530-1274)



3200 W Running | 4000 W Starting

Features

- Quiet running: meets National Park Service campground requirements
- At 51-58 dB, it's quieter than a normal conversation¹
- Safety compliant for worksite use (OSHA compliant)
- Clean, regulated A/C power for sensitive electronics (< 3% THD)
- CO DEFENSE™ technology keeps you, your family and friends safe
- 2x USB Ports, including a 2.1 Amp port for charging your tablet



Because of continuing improvements, actual product may differ slightly from this photo.

Control Panel



¹Average sound level of normal conversation is 60 dB cdc.gov

INV4000 E Inverter Generator

CO (501-5454) / Non-CO (530-1274)



Specifications

ENGINE	
Starting Method	Pull or Electric Push Button
Run Time @ 50% Load	8 hours
Idle Control	Engine Smart Control (ESC)
Fuel Tank Nominal Capacity	2.1 gal / 8 L
Fuel Tank Material	Plastic
Fuel Type	Unleaded Gasoline \geq 86 octane ¹
Fuel Gauge	Digital Gauge
Engine Displacement	212 cc
Engine Type	OHV
Engine Speed	Variable
Lubrication Method	Splash
Recommended Oil	SAE 30 or 10W-30
Oil Capacity	0.56 qt / 0.53 L
Region Certifications	CO: EPA, CARB / Non-CO: EPA, CSA
Shutdown Method	Automatic Low Oil Level

ELECTRICAL	
Running Power	3200 Watts
Starting Power	4000 Watts
AC Output	120V @ 60 Hz
DC Output	12V (8.3A) / 5V (2.1A)
Total Harmonic Distortion (THD)	< 3%
Receptacles	(1) 5-20R GFCI Duplex, (1) L5-30R, (1) 5V 2.1A USB, (1) 5V 1.0A USB, (1) 12 VDC 8.3A
Voltage Regulation	Inverter Type
Battery Type	Self-Charging Lithium Ion

EXTRA FEATURES	
LED Illuminated Control Panel	Yes
Carbon Monoxide Shutdown	Yes ²
Handle Style	Folding
Wheel Type	Never-Flat
Indicator Lights	Low Oil, Overload, Low Battery, Low Fuel and Service Needed
USB	1x 2.1A 5V and 1x 1.0A 5V

WARRANTY Standard 2-year limited, extended 3-year limited when registered within 30 days at cat.com/homeandoutdoorpower-warranty

¹ No more than 10% ethanol; fuel stabilizer should also be used for storage ² Only on CO Model

Dimensions and Weights

ASSEMBLED	
Height	20.4 in / 517 mm
Width	18.5 in / 470 mm
Length	25.4 in / 645 mm
Extended Length	40.2 in / 1021 mm
Unit Weight (Dry)	104.7 lbs / 47.5 kg

CARTON	
Height	20.7 in / 525 mm
Width	20.1 in / 510 mm
Length	28.3 in / 720 mm
Shipping Weight	118.4 lbs / 53.7 kg

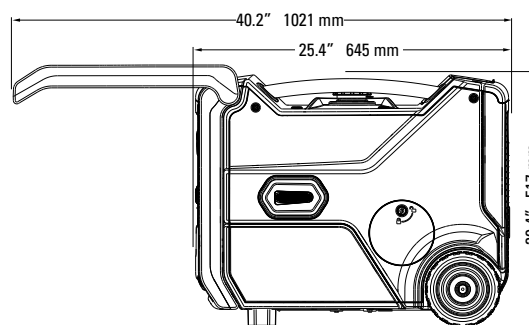
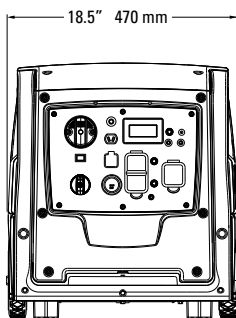

Accessories

Protective Cover
(589-6252)



30 Amp Inverter Parallel Kit
(530-1202)



CATERPILLAR®

© 2020 Caterpillar. All Rights Reserved. CAT, CATERPILLAR, LET'S DO THE WORK their respective logos, "Caterpillar Yellow," the "Power Edge" and "Modern Hex" trade dress, as well as corporate and product identity used herein, are trademarks of Caterpillar and may not be used without permission.



For more information:
cat.com/homeandoutdoorpower

LEHQ0068-00