

Perkins® Syncro 3.6 for Tractors

EU Stage V/U.S. EPA Tier 4 Final/
Japan MLIT Step 4

55 kW (74 hp)/70-100 kW (94-134 hp)

Agricultural Tractor Engine
Industrial

The Perkins® Syncro 3.6 engine offers the perfect solution for frameless agricultural tractors - compact, powerful and quiet.

Compact packaging including structural capability for front bolster and rear transmission, including twin balancers for operator comfort and rigid mounting; the Perkins Syncro 3.6 is the cornerstone of your tractor.

Our tight engine packaging combined with our compact aftertreatment is able to be mounted under the tractor bonnet. This enables tight turning circles and uninterrupted sight lines with no A-Pillar or battery box interference; the Perkins Syncro 3.6 enables less administration and easy logistics for the original equipment manufacturer.

Powerful, with excellent performance in power, peak and low speed torque, fuel consumption and transient response; the Perkins Syncro 3.6 has all the performance required including for downsizing from larger displacement engines for your tractor and your customers.

A naturally quiet engine by design, your customers will be impressed with the noise and sound quality of the engine, making the Perkins Syncro 3.6 a natural choice for tractors used around livestock and noise sensitive areas.

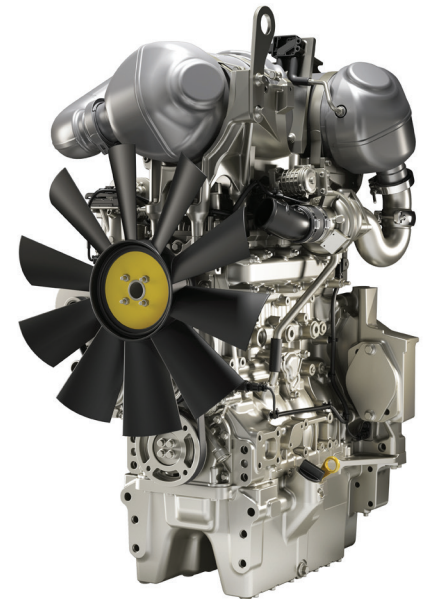

Specification

Cylinders	4 vertical in-line
Displacement litres	3.6 litres (220.9 in ³)
Aspiration	Turbocharged aftercooled
Bore and stroke mm (in)	98 x 120 mm (3.9 x 4.7 in)
Maximum power kW (hp)	100 kW (134 hp)
Maximum torque Nm (lb ft) @ rpm	530 Nm (391 lb ft) @ 1500 rpm
Combustion system	Direct injection
Weight kg (lb)	450 (992)
Rotation (viewed from flywheel)	Anti-clockwise, viewed on flywheel

For more information please contact a Perkins distributor: <http://distributorlocator.perkins.com>

All information in this document is substantially correct at time of printing and may be altered subsequently.
Photographs are for illustrative purposes only and may not reflect final specification.
Final weight and dimensions will depend on completed specification.
Information subject to selected configuration, and subject to change without notice
Performance measured per ISO 14396
Publication No. PN3229/09/19 Produced in England ©2019 Perkins Engines Company Limited

 **Perkins®**

THE HEART OF EVERY GREAT MACHINE

Perkins® Syncro 3.6 for Tractors

Agricultural Tractor Engine
Industrial

EU Stage V/U.S. EPA Tier 4 Final/
Japan MLIT Step 4

Japan MLIT Step 4

55 kW (74 hp)/70-100 kW (94-134 hp)

Features and benefits

Dependable power

- The engine has been designed using the latest predictive engineering methods, combined with an extensive field validation program to ensure reliable power in the toughest off-highway conditions
- Quality, reliability and consistency are assured. Our facilities worldwide employ the same efficient processes, the same tested and validated components, and the same stringent quality controls wherever your engines are manufactured

Lifetime of low cost

- Fuel consumption is optimised to match the operating cycles of a wide range of agricultural tractors
- Hydraulic tappets, multi-vee belts and 500 hour service intervals enable low cost maintenance

Warranties and Perkins Platinum Protection

- We provide one-year warranties for constant speed engines and two-year warranties for variable speed models, as standard. These are supported by Perkins Platinum Protection that can be bought additionally.
- Discover more: www.perkins.com 'Parts and Service'

Industry leading flexibility

- A modular engine concept allows OEMs to design one tractor for different regions. This reduces cost and development time for cooling pack, mounting, hydraulic and control interfaces.

Local support, global coverage

- Perkins recognise that the customer relationship is important to machine manufacturers and we can offer a range of flexible solutions to help provide appropriate support, either to the OEM's network or directly to the machine customer
- Perkins information systems enable our distributors to quickly diagnose engine faults and identify the right parts.
- The Perkins logistics operation is able to dispatch more than 45,000 different parts from stock, reaching the customer within 24 hours
- To find your local distributor: www.perkins.com 'Our Network'

For more information please contact a Perkins distributor: <http://distributorlocator.perkins.com>

All information in this document is substantially correct at time of printing and may be altered subsequently.
Photographs are for illustrative purposes only and may not reflect final specification.
Final weight and dimensions will depend on completed specification.
Information subject to selected configuration, and subject to change without notice
Performance measured per ISO 14396
Publication No. PN3229/09/19 Produced in England ©2019 Perkins Engines Company Limited



THE HEART OF EVERY GREAT MACHINE

Perkins® Syncro 3.6 for Tractors

Agricultural Tractor Engine
Industrial

EU Stage V/U.S. EPA Tier 4 Final/
Japan MLIT Step 4

55 kW (74 hp)/70-100 kW (94-134 hp)

Standard equipment

Controls and electrics

- 12V systems
- Data interface via CANbus J1939
- Full electronic control
- High power alternator and starter motor options
- Glow plugs for best cold starting with minimum battery impact
- Sensors and robust wiring harness included
- Wide choice of interfaces for common transmissions

Fuel system

- Electronic high pressure common rail
- Fuel filter - chassis mounted
- Water sensor included - early warning for operator

Lubrication system

- Oil filters. Mounting options available on either side of the engine, plus remote
- Dipsticks. Choice of position and length
- Oil fillers. Multiple locations on engine to allow for choice of service access
- High incline sump. 25° continuous in all directions

Power take-off

- SAE-A and SAE-B interfaces available

Standard emissions control

- Diesel Oxidation Catalyst (DOC), Diesel Particulate Filter (DPF)
- For engine power ratings above 56 kW, Selective Catalytic Reduction (SCR) will also be added
- Aftertreatment mounted on engine as standard, remote available

General

- Cold-start capable with standard equipment to -25°C
- Supplied painted or lacquered
- Structural sump including twin balancers for front bolster mounting
- Ag backplate for transmission mounting

For more information please contact a Perkins distributor: <http://distributorlocator.perkins.com>

All information in this document is substantially correct at time of printing and may be altered subsequently.
Photographs are for illustrative purposes only and may not reflect final specification.
Final weight and dimensions will depend on completed specification.
Information subject to selected configuration, and subject to change without notice
Performance measured per ISO 14396
Publication No. PN3229/09/19 Produced in England ©2019 Perkins Engines Company Limited

 **Perkins®**

THE HEART OF EVERY GREAT MACHINE

Perkins® Syncro 3.6 for Tractors

Agricultural Tractor Engine
Industrial

EU Stage V/U.S. EPA Tier 4 Final/
Japan MLIT Step 4

55 kW (74 hp)/70-100 kW (94-134 hp)

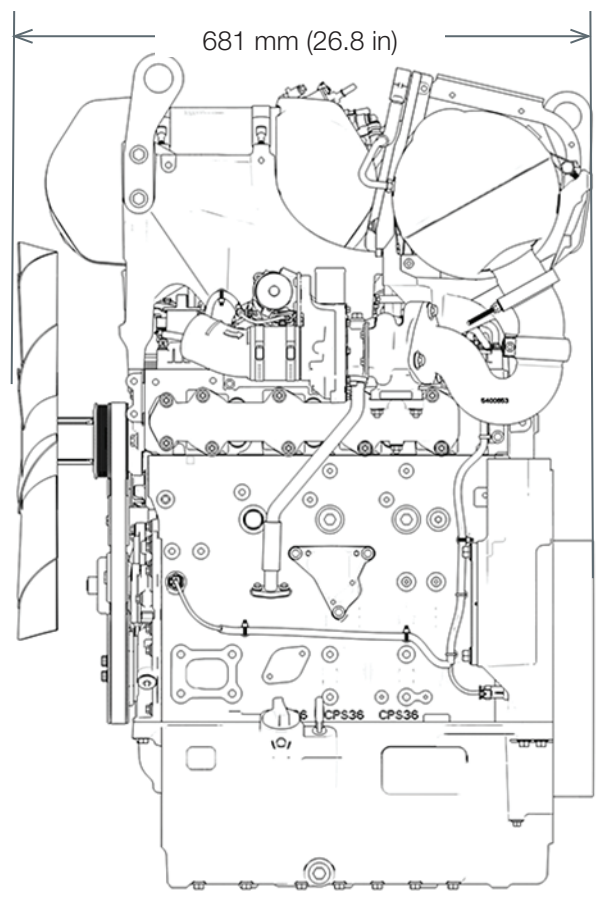
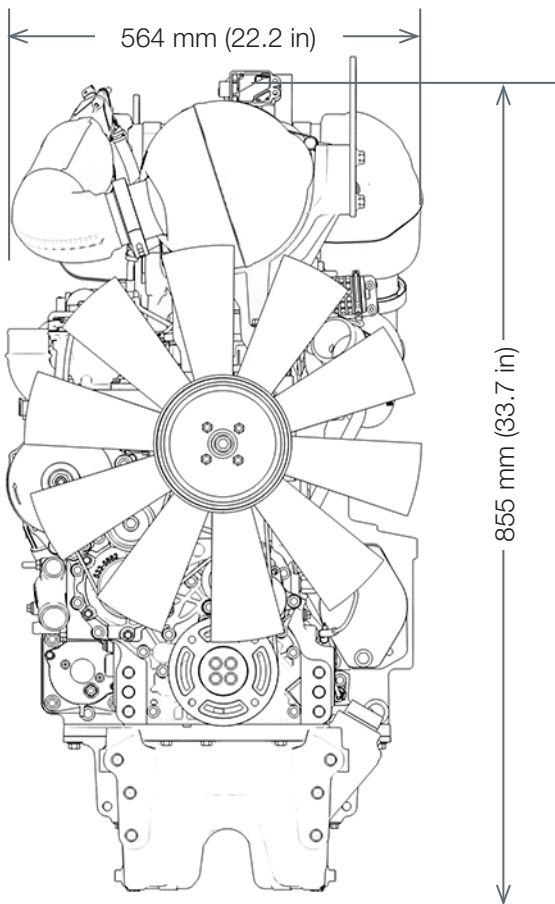
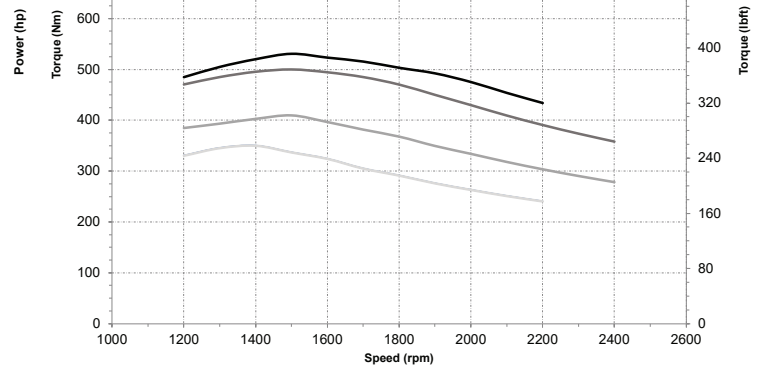
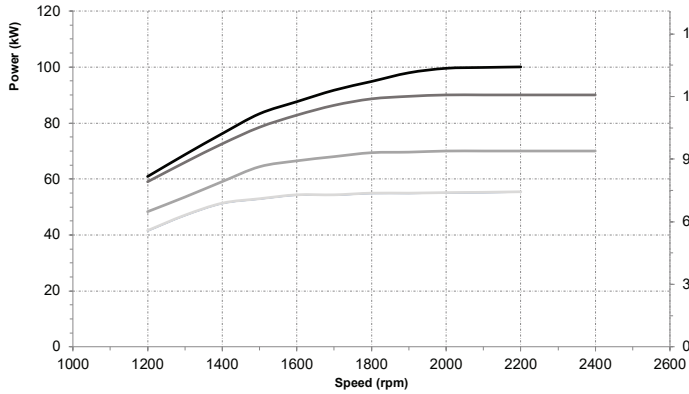

For more information please contact a Perkins distributor: <http://distributorlocator.perkins.com>

All information in this document is substantially correct at time of printing and may be altered subsequently.
Photographs are for illustrative purposes only and may not reflect final specification.
Final weight and dimensions will depend on completed specification.
Information subject to selected configuration, and subject to change without notice
Performance measured per ISO 14396
Publication No. PN3229/09/19 Produced in England ©2019 Perkins Engines Company Limited

 **Perkins®**

THE HEART OF EVERY GREAT MACHINE