

G16CM34 • Gas Engine

6,100 kW (8,180 hp) • 750 rpm

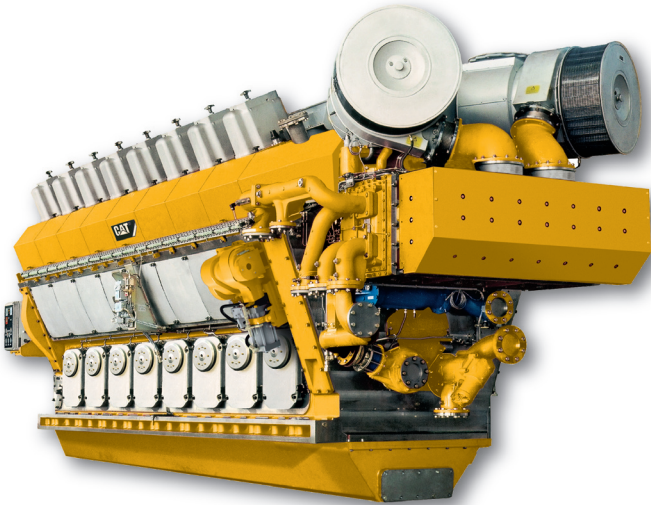

Image shown may not reflect actual engine

Cat® Engine Specifications

V-16, 4-Stroke-Cycle

Emissions	U.S. EPA SI NSPS Site Compliant Capable
Displacement	610 L (37,209 in ³)
Rated Speed Turndown	450 rpm
Bore	340 mm (13.38 in)
Stroke	420 mm (16.54 in)
Effective Compression Ratio	11.4:1
Aspiration	Turbocharged-2 Stage Aftercooled
Governor and Protection	Electronic (ADEM™ A3)
Engine Weight, net dry	
(approx)	82,000 kg (181,000 lb)
Power Density	13.44 kg/kW (22.1 lb/hp)
Power per Displacement	10 kW/L (0.22 hp/in ³)
Capacity for Liquids*	
Lube Oil System	3,157 L (834 U.S. gal)
HT Cooling Water System	2,343 L (619 U.S. gal)
LT Cooling Water System	651 L (172 U.S. gal)
Oil Change Interval	7,500 hours
Mean Piston Speed	10.7 m/s (34.6 ft/s)
Mean Effective Pressure	16 bar (232 psi)
Swept Volume of Cylinder	38.1 L (2,325 in ³)
Rotation per ISO 1204	Counterclockwise
Flywheel Teeth	408

* Volumes provided are the engine manufacturer's scope of supply and do not include volume needed for interconnecting lines, coolers etc.

Features

Technical Description

The G16CM34 is a natural gas, spark ignited, V-style, turbo-charged and aftercooled engine that provides: low emissions, high efficiency, high reliability, high flexibility, constant torque and variable speed.

The engine achieves high efficiency and low emissions by utilizing solenoid operated gas admission valves, enriched pre-chamber design, and Cat® ADEM A3 control technology.

Cylinder Block

- One-piece design for strength and rigidity
- Underslung crankshaft reduces weight and provides easy access to bearings for service
- Dry cylinder block (waterless) offers reduced repair times and increased strength
- Crankcase pressure relief devices
- Designed for block or skid mounting

Cylinder Head

- Individual cylinder heads with two inlet and two exhaust valves per cylinder
- Water-cooled exhaust seats to increase life
- Nitrided valves with automatic rotators

Fuel System

- Lean burn combustion system with independent fuel control for main chamber and prechamber
- Inlet pressure range is 50 to 87 psig
- Solenoid operated gas admission valve (SOGAV) on each cylinder to control fuel injection

Exhaust Gas System

- Two front-mounted (non-flywheel end) turbochargers designed for constant pressure supercharging
- Variable geometry turbochargers will provide optimal air-fuel ratio control through a wide operating range by controlling its own manifold pressure
- Exhaust gas pipe manifold with one expansion joint per cylinder; connection allows easy maintenance and quick cylinder head removal

Website

For all your petroleum power requirements, visit www.cat.com/oilandgas

BUILT FOR IT.™



G16CM34 • Gas Engine • 6,100 kW (8,180 hp)

Features (continued)

Flywheels & Flywheel Housings

A flywheel with starting ring gear is shipped mounted, cover/guard not included.

Drive Coupling

A torsionally elastic high damping steel spring coupling is provided. The TVA study with up to eight compressor load cases is included.

Starting System

Equipped with turbine-type air starters (TDI) uses compressed air or natural gas for engine starting; 1,034 kPa (150 psi) minimum air pressure. Rear mounted.

Cooling/Lube Oil System

The engine includes an auxiliary skid that combines the cooling system and lubrication system functions. The standard cooling system separates the High Temperature (HT – includes JW) circuit from the Low Temperature (LT – includes 2nd stage of aftercooler) circuit. Thermostatic valves are included for each circuit.

Two-stage charge air cooler splits heat load between the HT and LT circuit, reducing the heat load to the LT system, minimizing cooler costs.

The lube oil system includes a automatic filter, plate and frame oil cooler, an engine-mounted gear-driven lubrication pump, and an electric motor-driven pre/post-lubricating pump. A pneumatically actuated thermostatic valve (controlled by the engine control panel) controls the lube oil temperature. All components mounted on a single baseplate with drip pan for pollution control. Interconnecting pipe between engine and cooling water/lube oil skid are by customer. Engine controls are by customer.

Engine Controls and Instrumentation

The engine utilizes the ADEM A3 engine management system for speed regulation, individual cylinder detonation control, closed loop air/fuel ratio control, engine monitoring and protection.

Electronically controlled pneumatic actuated valves control the main and pilot fuel gas pressure.

System also includes an operator interface for displaying operating parameters and system messages. This system includes a local control panel with PLC for additional engine management and protection. Protection provided by this system includes:

- Engine control panel with PLC and operator control interface
- Floor-standing enclosure with window kit for touch screen
- Supplied local control panel includes space to incorporate compressor PLC, which can be displayed on same screen

Crankcase Ventilation Systems

- Design includes multi-stage oil remover with metal elements and paper filter
- Capacity – 340 m³/h (200 scfm)

Painting

The engine is painted Cat yellow, other colors can be provided. Caterpillar Motoren's standard paint system will be used.

Testing

Each engine is factory tested before shipment from Kiel, Germany. Test reports will be provided as part of the standard documentation.

Dimensions		
Length (A)	mm (in)	8,405 (331)
Length (B)	mm (in)	7,275 (287)
Width (C)	mm (in)	2,992 (118)
Height (D)	mm (in)	3,917 (154)
Package Weight	kg (lb)	82,000 (181,780)

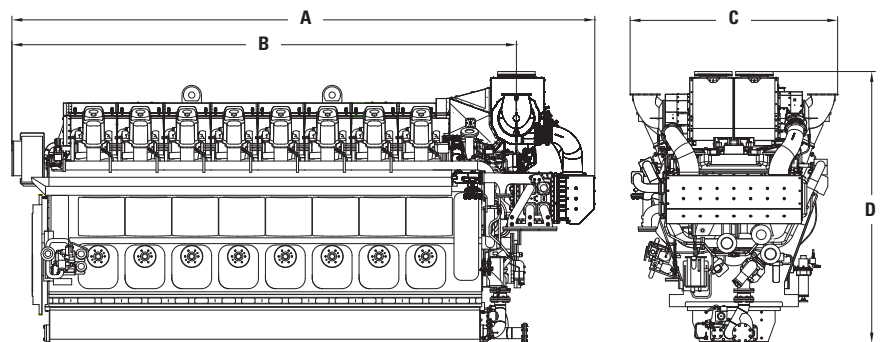

Note: General configuration not to be used for installation.

Technical Data • G16CM34 • 6,100 kW (8,180 hp) • 750 rpm

Fuel System		0.5 g/hph NO _x G16CM34	0.7g/hph NO _x (NTE) G16CM34
Engine Power			
@ 100% Load	kW (hp)	6,100 (8,180)	6,100 (8,180)
@ 75% Load	kW (hp)	4,575 (6,135)	4,575 (6,135)
Engine Speed min./max.			
	rpm	450/750	450/750
Aftercooler Temperature inlet			
	°C (°F)	45 (111)	45 (111)
Compression Ratio			
		11.4:1	11.4:1
Emissions (NTE)*			
NO _x	g/kWh (g/hph)	0.67 (0.50)	0.94 (0.70)
CO	g/kWh (g/hph)	4.2 (3.20)	4.2 (3.20)
Total Hydrocarbons	g/kWh (g/hph)	10.6 (7.90)	10.1 (7.50)
Fuel Consumption			
@ 100% Load	MJ/kWh (Btu/hph)	8.33 (5,890)	8.2 (5,796)
@ 75% Load	MJ/kWh (Btu/hph)	8.93 (6,314)	8.67 (6,206)
Heat Balance			
Heat Rejection to Jacket Water			
@ 100% Load	kW (Btu/min)	1,068 (60,751)	898 (51,108)
@ 75% Load	kW (Btu/min)	800 (45,563)	673 (38,831)
Heat Rejection to Atmosphere			
@ 100% Load	kW (Btu/min)	361 (20,550)	555 (31,616)
@ 75% Load	kW (Btu/min)	270 (15,413)	417 (23,713)
Heat Rejection to Aftercooler			
Stage 1			
@ 100% Load	kW (Btu/min)	1,259 (71,690)	1,343 (76,449)
@ 75% Load	kW (Btu/min)	944 (53,768)	1,007 (57,336)
Stage 2			
@ 100% Load	kW (Btu/min)	571 (32,533)	589.4 (33,545)
@ 75% Load	kW (Btu/min)	428 (24,400)	442 (25,159)
Heat Rejection to Lube			
Oil Cooler	kW (Btu/min)	1,050 (59,755)	1,050 (59,755)
Exhaust System			
Exhaust Gas Flow Rate			
@ 100% Load	m ³ /h (cfm)	33,647 (20,933)	33,671 (20,947)
@ 75% Load	m ³ /h (cfm)	24,487 (15,234)	25,623 (15,941)
Exhaust Stack Temperature			
@ 100% Load	°C (°F)	345 (653)	350 (662)
@ 75% Load	°C (°F)	380 (716)	390 (734)
Intake System			
Air Inlet Flow Rate			
@ 100% Load	m ³ /h (cfm)	32,300 (20,094)	33,300 (20,716)
@ 75% Load	m ³ /h (cfm)	24,487 (15,223)	24,487 (15,223)
Gas Pressure			
	kPag (psig)	414 (60)	414 (60)

* at 100% load

Rating Definitions and Conditions

Engine performance is obtained in accordance with SAE J1995, ISO3046/1, BS5514/1, and DIN6271/1 standards.

Transient response data is acquired from an engine/generator combination at normal operating temperature and in accordance with ISO3046/1 standard ambient conditions. Also in accordance with SAE J1995, BS5514/1, and DIN6271/1 standard reference conditions.

Conditions: Power for gas engines is based on fuel having an LHV of 33.74 kJ/L (905 Btu/cu ft) at 101 kPa (29.91 in Hg) and 15°C (59°F). Fuel rate is based on a cubic meter at 100 kPa (29.61 in Hg) and 15.6°C (60.1°F). Air flow is based on a cubic foot at 100 kPa (29.61 in Hg) and 25°C (77°F). Exhaust flow is based on a cubic foot at 100 kPa (29.61 in Hg) and stack temperature.

Caterpillar Oil & Gas

Headquarters

Caterpillar Inc.

Caterpillar Oil & Gas
10203 Sam Houston Park Drive
Houston, Texas 77040 4667
Phone: (+1) 713 329 2207
Telefax: (+1) 713 895 4280

Europe, Africa, Middle East and CIS

Caterpillar Commercial Northern Europe Ltd.

Caterpillar Oil & Gas
OTV House
Wokingham Road, Rounds Hill
Bracknell, Berkshire
United Kingdom, RG42 1 NG
Phone: (+44) 1344 782 920
Telefax: (+44) 1344 782 930

Caterpillar Motoren GmbH & Co. KG

Caterpillar Oil & Gas
Falckensteiner Str. 2
D-24159 Kiel, Germany
Phone: (+49) 431 3995 3004
Telefax: (+49) 431 3995 5004

Caterpillar CIS LLC

82 Sadovnicheskaya Str.
Moscow 113035, RF
Phone: (+7) 495 755 6811
Telefax: (+7) 495 785 5688

Asia Pacific

Caterpillar Oil & Gas China

Room 1601 Caterpillar Tower
No. 8 Wangjing Street
Beijing 100102, P.R. China
Phone: (+86) 10 5921 0521
Telefax: (+86) 10 5921 0022

Caterpillar Asia Pte., Ltd

14 Tractor Road
Singapore 627963
Republic of Singapore
Phone: (+65) 6828 7333
Telefax: (+65) 6828 7414

For more information please visit our website:
www.cat.com/oilandgas

Subject to change without notice.
Leaflet No. 728GP · 09.15 · e · L+S · VM3
LEHW0001-03

© 2015 Caterpillar All Rights Reserved. Printed in Germany. CAT, CATERPILLAR, their respective logos, ACERT, ADEM, „Caterpillar Yellow“ and the POWER EDGE trade dress, as well as corporate identity used herein, are trademarks of Caterpillar and may not be used without permission.



Caterpillar Oil & Gas is committed to sustainability. This document is printed on PEFC certified paper.

