



# Cat<sup>®</sup> 299D3 XE Land Management COMPACT TRACK LOADER

## FEATURES:

The Cat<sup>®</sup> 299D3 XE Land Management Compact Track Loader is a segment focused machine solution for customers involved in demanding vegetation-management applications, ranging from mulching, brush-cutting, vegetation control, and mowing.

The 299D3 XE Land Management machine's powerful Cat C3.8 engine combined with its high-flow/high-pressure auxiliary hydraulic system to deliver a calculated hydraulic power rating of 70 kW (94 hp), resulting in optimum performance when powering high-production, hydro-mechanical attachments. The 299D3 XE Land Management features the following:

- **Industry leading sealed and pressurized cab option** provides a cleaner and quieter operating environment with excellent Work Tool visibility.
- **Available high-back, heated, air ride seat with seat mounted adjustable joystick controls** makes Cat Compact Track Loaders the industry leader in operator comfort.
- **High performance power train** provides maximum performance and production capability through the Electronic Torque Management system, standard two speed travel and an electronic hand/foot throttle with decel pedal capability.
- **XE hydraulic system** provides high flow and high pressure that delivers industry leading hydraulic horsepower to efficiently run even the most power hungry work tools.
- **Extended working time** provided by large capacity external fuel tanks (220 L/58 gal – total).
- **Factory-equipped guarding and sealing** components to provide additional protection for areas that could be exposed to damage and to help reduce debris entry.
- **Standard fully independent torsion axle suspension** combined with the Speed Sensitive Ride Control system improves operation on rough terrain, enabling better load retention, increased productivity and greater operator comfort.
- **Maximize machine capability and control** with the standard Advanced Display providing on-screen adjustments for implement response, hystat response, and creep control, multi-language functionality with customizable layouts, security system, and rearview camera.
- **Ground level access** to all daily service and routine maintenance points helps reduce machine downtime for greater productivity.
- **Broad range of performance matched Cat Work Tools** make the Cat Compact Track Loader the most versatile machine on the job site.

## Specifications

### Engine

Engine Model	Cat C3.8 DIT (turbo)	
Gross Power SAE J1995	82 kW	110 hp
Net Power SAE 1349	79 kW	106 hp
Net Power ISO 9249	80 kW	107 hp
Peak Torque at 1,500 rpm SAE J1995	374 N·m	276 lbf·ft
Displacement	3.8 L	232 in <sup>3</sup>
Stroke	120 mm	4.7 in
Bore	100 mm	3.9 in

### Weights\*

Operating Weight	5790 kg	12,764 lb
------------------	---------	-----------

\*Operating Weight, Operating Specifications and Dimensions all based on 75 kg (165 lb) operator, all fluids, two speed, ride control, enclosed cab with polycarbonate door, side windows, air conditioning, air ride seat, advanced display, rearview camera, 1,000 CCA battery, dual direction self level, 2036 mm (80 in) low profile bucket, 400 mm (15.7 in) tracks, triple flange front/rear idlers, and manual quick coupler.

### Power Train

Travel Speed (Forward or Reverse):			
One Speed	8.9 km/h	5.5 mph	
Two Speed	13.3 km/h	8.3 mph	

### Hydraulic System

Hydraulic Flow – XE:			
Maximum Loader Hydraulic Pressure	28 000 kPa	4,061 psi	
Maximum Loader Hydraulic Flow†	150 L/min	40 gal/min	
Hydraulic Power (calculated)	70 kW	94 hp	
Standard Flow Mode:			
Loader Hydraulic Pressure	23 000 kPa	3,335 psi	
Loader Hydraulic Flow	86 L/min	23 gal/min	
Hydraulic Power (calculated)	33 kW	44 hp	

†When equipped with Cat 400 Series work tools.



# 299D3 XE Land Management Compact Track Loader

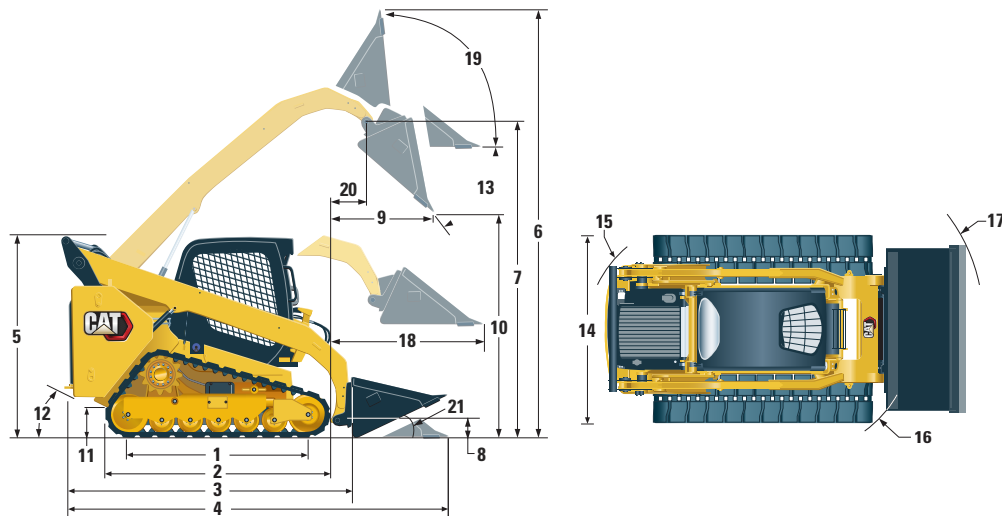

## Dimensions\*

1	Length of Track on Ground	1767 mm	69.6 in	12	Departure Angle	33°
2	Overall Length of Track	2270 mm	89.4 in	13	Maximum Dump Angle	54°
3	Length without Bucket	3189 mm	125.5 in	14	Vehicle Width (400 mm/15.7 in tracks)	1931 mm 76.0 in
4	Length with Bucket on Ground	3931 mm	154.7 in		Vehicle Width (450 mm/17.7 in tracks)	1982 mm 78.0 in
5	Height to Top of Cab	2125 mm	83.6 in	15	Turning Radius from Center – Machine Rear	1881 mm 74.0 in
6	Maximum Overall Height	4032 mm	158.7 in	16	Turning Radius from Center – Coupler	1476 mm 58.1 in
7	Bucket Pin Height at Maximum Lift	3208 mm	126.3 in	17	Turning Radius from Center – Bucket (racked)	2314 mm 91.1 in
8	Bucket Pin Height at Carry Position	180 mm	7.1 in	18	Maximum Reach with Arms Parallel to Ground	1319 mm 51.9 in
9	Reach at Maximum Lift and Dump	852 mm	33.6 in	19	Rack Back Angle at Maximum Height	81°
10	Clearance at Maximum Lift and Dump	2399 mm	94.5 in	20	Bucket Pin Reach at Maximum Lift	493 mm 19.4 in
11	Ground Clearance	245 mm	9.6 in	21	Roll Back Angle	25°

## Operating Specifications\*

Rated Operating Capacity:			
35% Tipping Load	1975 kg	4,340 lb	
50% Tipping Load	2820 kg	6,200 lb	
Tipping Load	5635 kg	12,400 lb	
Breakout Force, Tilt Cylinder	3298 kg	7,270 lb	
Breakout Force, Lift Cylinder	2795 kg	6,162 lb	
Ground Contact Area (400 mm/15.7 in track)	1.41 m <sup>2</sup>	2,171 in <sup>2</sup>	
Ground Contact Area (450 mm/17.7 in track)	1.58 m <sup>2</sup>	2,443 in <sup>2</sup>	
Ground Pressure (400 mm/15.7 in track)	40.5 kPa	5.9 psi	
Ground Pressure (450 mm/17.7 in track)	35.8 kPa	5.2 psi	

## Cab

ROPS	ISO 3471:2008
FOPS	ISO 3449:2005 Level I

## Service Refill Capacities

Cooling System	16 L	4.1 gal
Diesel Exhaust Fluid (DEF) Tank	19 L	5 gal
Engine Crankcase	13 L	3.5 gal
Fuel Tank	220 L	58 gal
Hydraulic System	55 L	14.5 gal
Hydraulic Tank	39 L	10.3 gal

## Noise Level

Inside Cab**	83 dB(A)
Outside Cab***	104 dB(A)

- Sealed and pressurized cab is standard in North America and Europe.
- \*\*The declared dynamic operator sound pressure levels per ISO 6396:2008. The measurements were conducted with the cab doors and windows closed and at 70% of the maximum engine cooling fan speed. The sound level may vary at different engine cooling fan speeds.
- \*\*\*The labeled sound power level for the CE marked configurations when measured according to the test procedure and conditions specified in 2000/14/EC.

## Air Conditioning System (if equipped)

The air conditioning system on this machine contains the fluorinated greenhouse gas refrigerant R134a (Global Warming Potential = 1430). The system contains 0.81 kg of refrigerant which has a CO<sub>2</sub> equivalent of 1.158 metric tonnes.

# 299D3 XE Land Management Compact Track Loader

## MANDATORY EQUIPMENT

---

- Quick Coupler, Mechanical or Powered
- High Visibility Seat Belt, 50 mm (2 in) or 75 mm (3 in)

## PERFORMANCE PACKAGE

- Performance Package H3: *XE Hydraulics, Dual Direction Electronic Self Level (Raise and Lower), Work Tool Return to Dig, Work Tool Positioner, and Electronic Snubbing (Raise and Lower)*

## STANDARD EQUIPMENT

---

### ELECTRICAL

- 12 volt Electrical System
- 100 ampere Alternator
- Ignition Key Start/Stop Switch
- Lights: *Gauge Backlighting, Two Rear Tail Lights, Two Rear LED Working Lights, Two Adjustable Front LED Lights, Dome Light*
- Backup Alarm
- Heavy Duty Battery, 1,000 CCA, with Battery Disconnect

### OPERATOR ENVIRONMENT

- Gauges: *Fuel Level, DEF Level, Hour Meter*
- Operator Warning System Indicators: *Air Filter Restriction, Alternator Output, Armrest Raised/Operator Out of Seat, Engine Coolant Temperature, Engine Oil Pressure, Air Inlet Heater Activation, Hydraulic Filter Restriction, Hydraulic Oil Temperature, Park Brake Engaged, Engine Emission System*
- High Back Cloth Seat with Air Suspension, Heated with Recline and Lumbar Support and Fully Adjustable Seat Mounted Controls
- Fold In Ergonomic Contoured Armrest
- Control Interlock System, when operator leaves seat or armrest raised: *Hydraulic System Disables, Hydrostatic Transmission Disables, Parking Brake Engages*
- ROPS Cab, Enclosed, Tilt Up
- FOPS, Level I
- Top, Rear and Side Windows
- Headliner, Deluxe
- Floor Mat
- Interior Rearview Mirror
- USB Charging Port
- Horn
- Hand (Dial) and Foot Throttle, Electronic with Decel Feature
- Advanced Display with Rearview Camera: *Full Color, 127 mm (5 in) LCD screen; Advanced Multi-operator Security System; On-screen Adjustments for Implement Response, Hystat Response and Creep Control*
- Storage Compartment with Netting

### COMFORT PACKAGE

- Enclosed ROPS with A/C (C3): *Foot Throttle, Headliner, Heater and Defroster, Side Windows, Cup Holder, Radio Ready, Air Ride Seat (High Back and Heated) and Polycarbonate Door*

### POWER TRAIN

- Cat C3.8, Turbo Diesel Engine, Meeting U.S. EPA Tier 4 Final and EU Stage IV Emission Standards
- Air Cleaner, Dual Element, Radial Seal
- S-O-S<sup>SM</sup> Sampling Valve, Hydraulic Oil
- Filters, Cartridge-type, Hydraulic
- Filters, Canister-type, Fuel and Water Separator
- Radiator/Hydraulic Oil Cooler (side-by-side)
- Spring Applied, Hydraulically Released, Wet Multi Disc Parking Brakes
- Hydrostatic Transmission, Two Speed Travel
- Suspension – Independent Torsion Axles (4)
- Speed Sensitive Ride Control

### OTHER

- Engine Enclosure, Lockable
- Extended Life Antifreeze, –37° C (–34° F)
- Machine Tie Down Points (6)
- Support, Lift Arm
- Hydraulic Oil Level Sight Gauge
- Radiator Coolant Level Sight Gauge
- Radiator, Expansion Bottle
- Cat ToughGuard<sup>TM</sup> Hose
- Auxiliary, Hydraulics, Continuous Flow
- Split D-Ring to Route Work Tool Hoses Along Side of Left Lift Arm
- Electrical Outlet, Beacon
- Belly and Engine Compartment Access Panels for Cleanout
- Variable Speed Demand Fan with Reversing Functionality
- Steel Embed Rubber Track – 400 mm (15.7 in) Block Tread
- Triple Flange Idlers (front and rear)
- Product Link<sup>TM</sup> PL240, Cellular
- Fire Extinguisher Mounting Bracket (in-cab)
- Screw-to-Connect Auxiliary Hydraulic Couplings (¼ in)
- Push-to-Connect Flat Faced Auxiliary Hydraulic Couplings (½ in)
- Debris Guarding (external and turbo)
- Precleaner for Engine Air Intake
- Additional Machine Guarding
- Drive-line Guarding
- Turbo Guard
- Additional Machine Sealing

# 299D3 XE Land Management Compact Track Loader

---

## OPTIONAL ATTACHMENTS

---

- Beacon, Rotating
- Engine Block Heater – 120V
- Oil, Hydraulic, Cold Operation
- Paint, Custom
- Product Link PL641, Cellular
- Bluetooth® Radio with Microphone (AM/FM/Weather Band Receiver with USB and Auxiliary Input Jack)
- Roof Mounted Auxiliary Hydraulic Cooler
- Steel Embed Rubber Track – 450 mm (17.7 in) Block Tread
- Steel Embed Rubber Track – 450 mm (17.7 in) BAR Tread
- Steel Track – 355 mm (14 in) Sealed and Lubricated Steel Track (SALT) with Triple Grouser Shoes

For more complete information on Cat products, dealer services, and industry solutions, visit us on the web at [www.cat.com](http://www.cat.com)

© 2019 Caterpillar  
All rights reserved

Materials and specifications are subject to change without notice. Featured machines in photos may include additional equipment. See your Cat dealer for available options.

CAT, CATERPILLAR, LET'S DO THE WORK, their respective logos, "Caterpillar Yellow," the "Power Edge" and Cat "Modern Hex" trade dress as well as corporate and product identity used herein, are trademarks of Caterpillar and may not be used without permission.

AEHQ8235 (08-2019)  
(Am North, ANZP)

