



Cat[®] CS44B

Smooth Drum Vibratory Soil Compactor

The Cat[®] CS44B features a smooth drum and is ideally suited for granular soil applications or cohesive soil applications with the use of an optional padfoot shell kit.

Comfortable and Ergonomic Operator Station

- Features adjustable seat with integrated multifunction LCD display and control console.
- Outstanding visibility to the front and rear of machine.
- Low sound levels and vibration for greater operator comfort and productivity.

Rear Vision Camera

- The rear vision camera enhances visibility for more complete operator control and safety.

Exceptional Propel System

- Built around the exclusive Cat dual pump propel system, two pumps provide separate dedicated flow to drum drive motor and rear axle motor for exceptional gradeability and traction in forward and reverse.

Virtually Maintenance Free

- Maintenance-free hitch bearings
- Extended maintenance intervals for vibratory system and hydraulic system, providing more uptime and lower maintenance costs.

Powerful Cat C4.4 Engine

- Meets regional emissions standards.

Optional Cat Compaction Control

- Helps operator determine when compaction has been completed to specification for greater productivity and uniform compaction quality.
- Accelerometer-based (CMV) measurement technology available.

Compact, highly maneuverable and transportable

Vibratory Soil Compactor Selection Guide

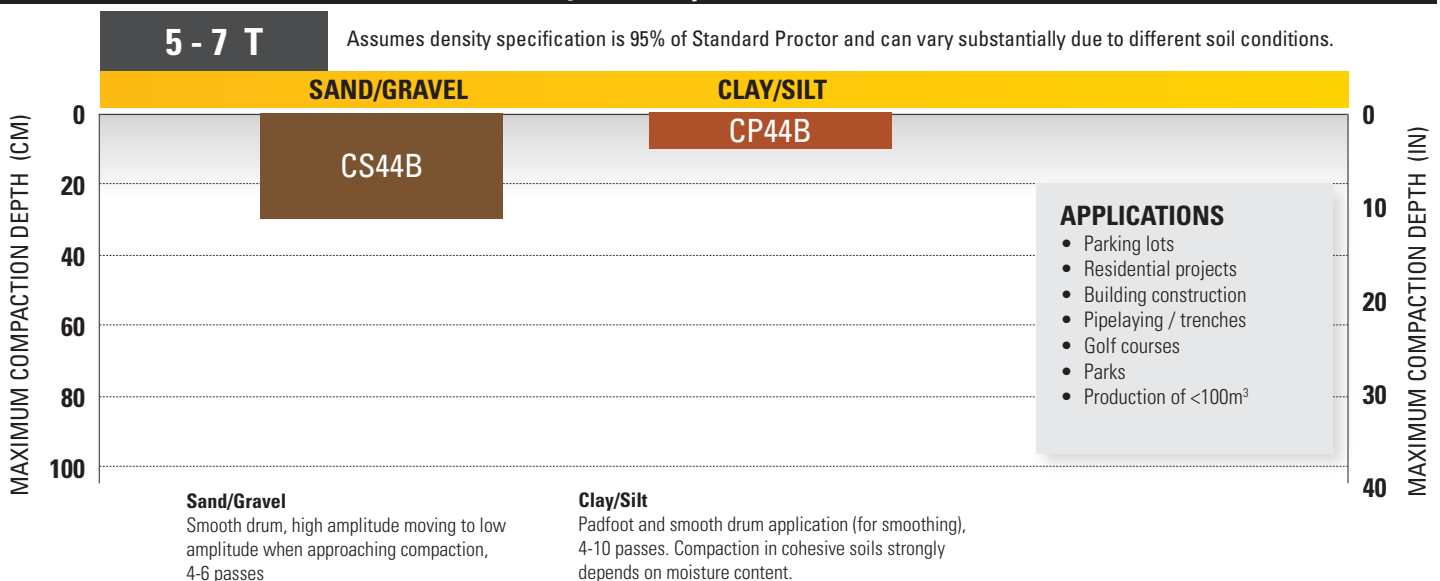

Not all models are available in each region. Contact your Cat[®] dealer representative for more information.



Cat® CS44B Padfoot Drum Vibratory Soil Compactor

Standard and Optional Equipment

Standard and optional equipment may vary. Consult your Cat dealer for details.

	Standard	Optional		Standard	Optional
OPERATOR ENVIRONMENT			POWER TRAIN		
ROPS/FOPS Canopy with Handrails, Floor Mat, Interior Rear View Mirror	✓		Cat® C4.4 Engine	✓	
Vinyl Adjustable Seat with Integrated Console and LCD Display with Lockable Vandalism Guard	✓		Air Cleaner, Dual Element	✓	
Adjustable Tilting Steering Column with Integrated Cup Holders	✓		Two-Speed Throttle Switch and Eco-mode	✓	
Rear Vision Camera System with Color Touchscreen Display	✓		Dual Propel Pumps; One for Drum Drive, One for Rear Axle	✓	
Seat Belt	✓		Fuel Filter, Water Separator, Priming Pump, Water Indicator	✓	
12-volt Power Outlet	✓		Tilting Radiator/Hydraulic Oil Cooler	✓	
Horn, Backup Alarm	✓		Dual Braking System	✓	
ROPS/FOPS Cab with Climate Control, Cloth Seat, Exterior Rear View Mirrors, Sun Visor, Roll-down Sun Screen		✓	Two-Speed Hydrostatic Transmission	✓	
VIBRATORY SYSTEM			Transmission Guard		✓
Smooth Drum	✓		TECHNOLOGY SOLUTIONS		
Dual Amplitude, Single Frequency	✓		Measure - Compaction Meter Value (CMV)		✓
Pod-Style Eccentric Weight Housings	✓		ELECTRICAL		
Auto-vibe Function	✓		12-volt Electrical System	✓	
Front Adjustable Steel Scrapers	✓		150 ampere Alternator	✓	
Padfoot Shell Kit (oval or square pads available)		✓	1000 Cold-cranking Amps Battery Capacity	✓	
Leveling Blade		✓	OTHER		
Variable Frequency		✓	Product Link™	✓	
Dual Adjustable Steel Scrapers		✓	Sight Gauges for Hydraulic Oil Level and Radiator Coolant Level	✓	
			S•O•S SM Sampling Valves: Engine Oil, Hydraulic Oil, and Coolant	✓	
			Upgraded Halogen Light Package		✓
			Amber Rotating Beacon		✓
			Factory Filled Bio-Hydraulic Oil		✓

Cat® CS44B Smooth Drum Vibratory Soil Compactor

Technical Specifications

Engine - Power Train		
Engine Model	Cat C4.4	
Emissions	U.S. EPA Tier 3 EU Stage IIIA Equivalent Brazil MAR-1	
Engine Power ISO 14396:2002	74.5 kW	99.9 hp
Gross Power SAE J1995:2014	75.3 kW	101.0 hp
Net Power ISO 9249:2007*	70.5 kW	94.5 hp
Net Power SAE J1349:2011*	69.7 kW	93.5 hp
Displacement	4.4 L	269 in ³
Stroke	127 mm	5.0 in
Bore	105 mm	4.1 in
Max. Travel Speed (Forward or Reverse)	11.4 km/h	7.0 mph
Theoretical Gradeability**	57%	

Weights***		
Operating Weight w/ ROPS/FOPS Canopy	6943 kg	15,307 lb
w/ Padfoot Shell Kit	8001 kg	17,639 lb
w/ Padfoot Shell Kit and Leveling Blade	8528 kg	18,801 lb
Operating Weight w/ ROPS/FOPS Cab	7210 kg	15,895 lb
w/ Padfoot Shell Kit	8232 kg	18,148 lb
w/ Padfoot Shell Kit and Leveling Blade	8711 kg	19,204 lb
Weight at Drum w/ ROPS/FOPS Canopy	3384 kg	7460 lb
w/ Padfoot Shell Kit	4418 kg	9740 lb
w/ Padfoot Shell Kit and Leveling Blade	5138 kg	11,327 lb
Weight at Drum w/ ROPS/FOPS Cab	3518 kg	7756 lb
w/ Padfoot Shell Kit	4490 kg	9899 lb
w/ Padfoot Shell Kit and Leveling Blade	5217 kg	11,502 lb

* Net power advertised is the power available at the engine flywheel when equipped with a fan at maximum speed, air cleaner, clean emissions module, and alternator.

** Actual gradeability may vary based on site conditions and machine configuration. Refer to the Operation and Maintenance Manual for more information.

*** Standard operating weight considers full fluids and 80 kg operator.

Vibratory System Specifications		
Frequency		
Standard	31.9 Hz	1914 vpm
During Eco-mode Operation	29 Hz	1744 vpm
Optional Variable Frequency	23.3 - 31.9 Hz	1400 - 1914 vpm
Nominal Amplitude @ 31.9 Hz (1914 vpm)		
High	1.67 mm	0.066 in
Low	0.84 mm	0.033 in
Centrifugal Force @ 31.9 Hz (1914 vpm)		
Maximum	133 kN	29,900 lb
Minimum	67 kN	15,000 lb
Static Linear Load		
w/ ROPS/FOPS Canopy	20.2 kg/cm	113 lbs/in
w/ ROPS/FOPS Cab	21.0 kg/cm	118 lbs/in

Service Refill Capacities		
Fuel Tank, total capacity	140 L	37.0 gal
Cooling System	19.5 L	5.3 gal
Engine Oil w/ Filter	9.5 L	2.5 gal
Eccentric Weight Housing	13 L	3.5 gal
Axle and Final Drives	14.6 L	3.9 gal
Hydraulic Tank (service refill)	26 L	6.9 gal

Cat® CS44B Smooth Drum Vibratory Soil Compactor

Technical Specifications

Dimensions

1	Overall Length	5.1 m	16.7 ft
	Overall Length w/ optional Leveling Blade	5.6 m	18.4 ft
2	Overall Width	1.8 m	5.9 ft
	Overall Width w/ optional Leveling Blade	2.1 m	6.95 ft
3	Drum Width	1676 mm	66 in
4	Drum Shell Thickness	25 mm	1 in
5	Drum Diameter	1221 mm	48.1 in
6	Overall Height		
	w/ ROPS/FOPS Cab	2.9 m	9.4 ft
	w/ ROPS/FOPS Canopy	2.8 m	9.2 ft
7	Wheelbase	2.6 m	8.5 ft
8	Ground Clearance	411 mm	16.2 in
9	Curb Clearance	369 mm	14.5 in
	Inside Turning Radius	3.1 m	10.0 ft
	Hitch Articulation Angle	37°	
	Hitch Oscillation Angle	15°	

Optional Padfoot Shell Kit Specifications

Number of Pads	98	
Pad Height, oval pads	86.8 mm	3.4 in
Pad Face Area, oval pads	63.8 cm ²	9.9 in ²
Pad Height, optional square pads	79.4 mm	3.1 in
Pad Face Area, optional square pads	95.5 cm ²	14.8 in ²
Number of Chevrons	14	

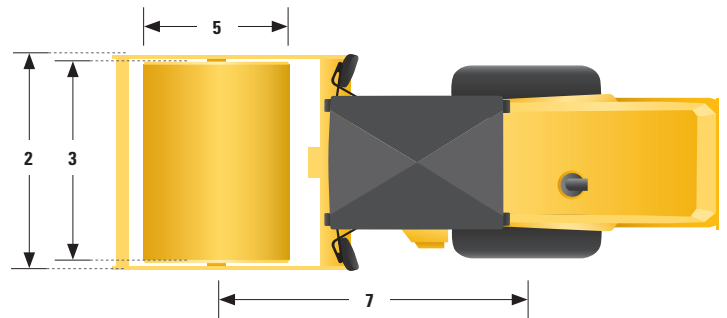
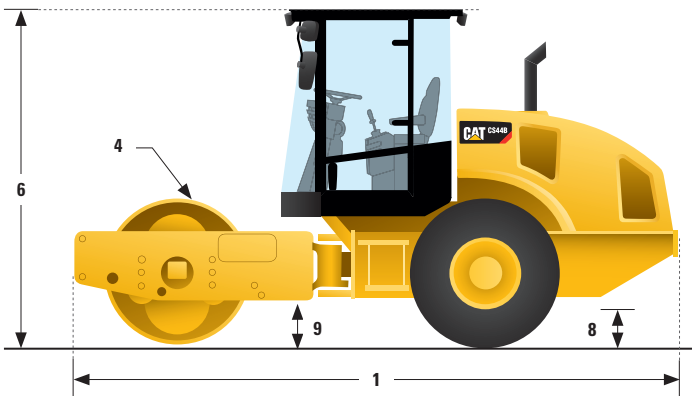

For more information on Cat products, dealer services, and industry solutions visit us on the web at www.cat.com.

© 2022 Caterpillar
All rights reserved.

Materials and specifications are subject to change without notice. Featured machines in photos may include additional equipment. See your Cat dealer for available options.

CAT, CATERPILLAR, LET'S DO THE WORK, their respective logos, "Caterpillar Corporate Yellow," the "Power Edge" and Cat "Modern Hex" trade dress as well as corporate and product identity used herein, are trademarks of Caterpillar and may not be used without permission.

QEHQ2286-03 (07-2022)
LRC

