

Cat® C175-20

Diesel Generator Sets



Image shown may not reflect actual configuration

| | |
|-------------------------------------|-----------------|
| Bore – mm (in) | 175 (6.89) |
| Stroke – mm (in) | 220 (8.66) |
| Displacement – L (in ³) | 105.8 (6456.31) |
| Compression Ratio | 15.3:1 |
| Aspiration | TA |
| Fuel System | Common Rail |
| Governor Type | ADEM™ A4 |

| Standby 60 Hz ekW (kVA) | Mission Critical 60 Hz ekW (kVA) | Prime 60 Hz ekW (kVA) | Continuous 60 Hz ekW (kVA) | Emissions Performance |
|----------------------------|-------------------------------------|--------------------------|-------------------------------|---|
| 4000 (5000) | 4000 (5000) | 3600 (4500) | 3250 (4062) | U.S. EPA Stationary Emergency Use Only (Tier 2) |

Standard Features

Cat® Diesel Engine

- Meets U.S. EPA Stationary Emergency Use Only (Tier 2) emission standards
- Reliable performance proven in thousands of applications worldwide

Generator Set Package

- Accepts 100% block load in one step and meets NFPA 110 loading requirements
- Conforms to ISO 8528-5 G3 load acceptance requirements
- Reliability verified through torsional vibration, fuel consumption, oil consumption, transient performance, and endurance testing

Alternators

- Superior motor starting capability minimizes need for oversizing generator
- Designed to match performance and output characteristics of Cat diesel engines

EMCP 4 Control Panels

- User-friendly interface and navigation
- Scalable system to meet a wide range of installation requirements
- Expansion modules and site specific programming for specific customer requirements

Warranty

- 24 months/1000-hour warranty for standby and mission critical ratings
- 12 months/unlimited hour warranty for prime and continuous ratings
- Extended service protection is available to provide extended coverage options

Worldwide Product Support

- Cat dealers have over 1,800 dealer branch stores operating in 200 countries
- Your local Cat dealer provides extensive post-sale support, including maintenance and repair agreements

Financing

- Caterpillar offers an array of financial products to help you succeed through financial service excellence
- Options include loans, finance lease, operating lease, working capital, and revolving line of credit
- Contact your local Cat dealer for availability in your region

Optional Equipment

Engine

Air Cleaner

- Single element

Muffler

- Industrial grade (15 dB)
- Residential grade (25 dB)
- Critical grade (35 dB)

Starting

- Standard batteries
- Oversized batteries
- Standard electric starter(s)
- Heavy duty electric starter(s)
- Dual electric starter(s)
- Air starter(s)
- Jacket water heater

Alternator

Output voltage

- 4160V 12470V
- 6300V 13200V
- 6600V 13800V
- 6900V

Temperature Rise (over 40°C ambient)

- 150°C
- 125°C/130°C
- 105°C
- 80°C

Winding type

- Form wound

Excitation

- Permanent magnet (PM)

Attachments

- Anti-condensation heater
- Stator and bearing temperature monitoring and protection

Control System

Controller

- EMCP 4.2B
- EMCP 4.3
- EMCP 4.4

Attachments

- Local annunciator module
- Remote annunciator module
- Expansion I/O module
- Remote monitoring software

Charging

- Battery charger – 20A
- Battery charger – 35A
- Battery charger – 50A

Vibration Isolators

- Rubber
- Spring
- Seismic rated

Cat Connect

Connectivity

- Ethernet
- Cellular
- Satellite

Extended Service Options

Terms

- 2 year (prime)
- 3 year
- 5 year
- 10 year

Coverage

- Silver
- Gold
- Platinum
- Platinum Plus

Ancillary Equipment

- Automatic transfer switch (ATS)
- Uninterruptible power supply (UPS)
- Paralleling switchgear
- Paralleling controls

Certifications

- IBC seismic certification
- OSHPD pre-approval

Note: Some options may not be available on all models. Certifications may not be available with all model configurations. Consult factory for availability.

Package Performance

| Performance | Standby | Mission Critical | Prime | Continuous |
|---|------------------|------------------|------------------|------------------|
| Frequency | 60 Hz | 60 Hz | 60 Hz | 60 Hz |
| Gen set power rating without fan | 4000 ekW | 4000 ekW | 3600 ekW | 3250 ekW |
| Gen set power rating without fan @ 0.8 power factor | 5000 kVA | 5000 kVA | 4500 kVA | 4062 kVA |
| Emissions | EPA ESE (Tier 2) | EPA ESE (Tier 2) | EPA ESE (Tier 2) | EPA ESE (Tier 2) |
| Performance number | DM8854-03 | EM0374-01 | DM8855-03 | DM8856-02 |
| Fuel Consumption | | | | |
| 100% load without fan – L/hr (gal/hr) | 1039.3 (274.6) | 1039.3 (274.6) | 925.3 (244.4) | 826.6 (218.4) |
| 75% load without fan – L/hr (gal/hr) | 770.6 (203.6) | 770.6 (203.6) | 708.7 (187.2) | 647.7 (171.1) |
| 50% load without fan – L/hr (gal/hr) | 615.2 (162.5) | 615.2 (162.5) | 574.5 (151.8) | 536.5 (141.7) |
| 25% load without fan – L/hr (gal/hr) | 364.6 (96.3) | 364.6 (96.3) | 336.4 (88.9) | 307.8 (81.3) |
| Cooling System | | | | |
| Engine coolant capacity – L (gal) | 440.0 (116.2) | 440.0 (116.2) | 440.0 (116.2) | 440.0 (116.2) |
| Inlet Air | | | | |
| Combustion air inlet flow rate – m ³ /min (cfm) | 339.1 (11975.3) | 339.1 (11975.3) | 315.2 (11129.1) | 284.5 (10045.6) |
| Exhaust System | | | | |
| Exhaust stack gas temperature – °C (°F) | 473.9 (885.0) | 473.9 (885.0) | 462.7 (864.9) | 452.1 (845.8) |
| Exhaust gas flow rate – m ³ /min (cfm) | 871.4 (30771.1) | 871.4 (30771.1) | 787.7 (27814.2) | 707.1 (24969.8) |
| Exhaust system backpressure (maximum allowable) – kPa (in. water) | 6.7 (27.0) | 6.7 (27.0) | 6.7 (27.0) | 6.7 (27.0) |
| Heat Rejection | | | | |
| Heat rejection to jacket water – kW (Btu/min) | 2147 (122108) | 2147 (122108) | 1865 (106088) | 1660 (94418) |
| Heat rejection to exhaust (total) – kW (Btu/min) | 3927 (223338) | 3927 (223338) | 3489 (198443) | 3088 (175609) |
| Heat rejection to aftercooler – kW (Btu/min) | 447 (25443) | 447 (25443) | 445 (25329) | 293 (16677) |
| Heat rejection to atmosphere from engine – kW (Btu/min) | 206 (11729) | 206 (11729) | 194 (11027) | 189 (10735) |
| Heat rejection from alternator – kW (Btu/min) | 171 (9725) | 171 (9725) | 158 (8974) | 128 (7302) |
| Emissions* (Nominal) | | | | |
| NOx mg/Nm ³ (g/hp-h) | 2653.8 (5.67) | 2653.8 (5.67) | 2755.7 (5.73) | 3020.8 (6.20) |
| CO mg/Nm ³ (g/hp-h) | 149.5 (0.36) | 149.5 (0.36) | 148.5 (0.37) | 184.3 (0.43) |
| HC mg/Nm ³ (g/hp-h) | 17.4 (0.05) | 17.4 (0.05) | 15.0 (0.04) | 19.1 (0.05) |
| PM mg/Nm ³ (g/hp-h) | 14.8 (0.04) | 14.8 (0.04) | 16.8 (0.05) | 13.6 (0.03) |
| Emissions* (Potential Site Variation) | | | | |
| NOx mg/Nm ³ (g/hp-h) | 3183.4 (6.81) | 3183.4 (6.81) | 3306.7 (6.87) | 3624.9 (7.45) |
| CO mg/Nm ³ (g/hp-h) | 269.1 (0.65) | 269.1 (0.65) | 267.3 (0.67) | 331.8 (0.77) |
| HC mg/Nm ³ (g/hp-h) | 23.1 (0.06) | 23.1 (0.06) | 19.9 (0.06) | 25.4 (0.07) |
| PM mg/Nm ³ (g/hp-h) | 20.7 (0.06) | 20.7 (0.06) | 23.5 (0.06) | 19.1 (0.05) |

*mg/Nm³ levels are corrected to 5% O₂. Contact your local Cat dealer for further information.

Weights and Dimensions

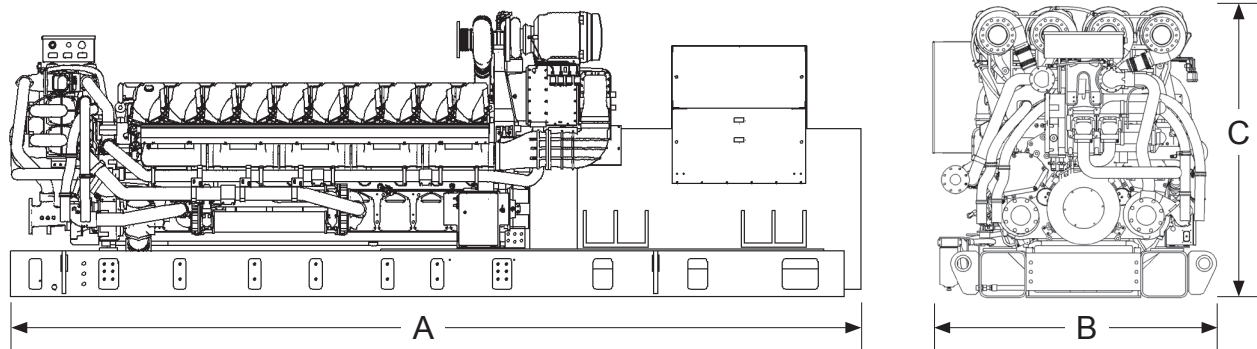

| Dim "A" mm (in) | Dim "B" mm (in) | Dim "C" mm (in) | Dry Weight kg (lb) |
|--------------------|--------------------|--------------------|-----------------------|
| 6643 (261.5) | 2170 (85.4) | 2224 (87.6) | 25 000 (55,100) |

Note: For reference only. Do not use for installation design. Contact your local Cat dealer for precise weights and dimensions.

Ratings Definitions

Standby

Output available with varying load for the duration of the interruption of the normal source power. Average power output is 70% of the standby power rating. Typical operation is 200 hours per year, with maximum expected usage of 500 hours per year.

Mission Critical

Output available with varying load for the duration of the interruption of the normal source power. Average power output is 85% of the mission critical power rating. Typical peak demand up to 100% of rated power for up to 5% of the operating time. Typical operation is 200 hours per year, with maximum expected usage of 500 hours per year.

Prime

Output available with varying load for an unlimited time. Average power output is 70% of the prime power rating. Typical peak demand is 100% of prime rated kW with 10% overload capability for emergency use for a maximum of 1 hour in 12. Overload operation cannot exceed 25 hours per year.

Continuous

Output available with non-varying load for an unlimited time. Average power output is 70-100% of the continuous power rating. Typical peak demand is 100% of continuous rated kW for 100% of the operating hours.

Applicable Codes and Standards

AS 1359, CSA C22.2 No. 100-04, UL 142, UL 489, UL 869, UL 2200, NFPA 37, NFPA 70, NFPA 99, NFPA 110, IBC, IEC 60034-1, ISO 3046, ISO 8528, NEMA MG1-22, NEMA MG1-33, 2014/35/EU, 2006/42/EC, 2014/30/EU.

Note: Codes may not be available in all model configurations. Please consult your local Cat dealer for availability.

Data Center Applications

- ISO 8528-1 Data Center Power (DCP) compliant per DCP application of Cat diesel generator set prime power rating.
- All ratings Tier III/Tier IV compliant per Uptime Institute requirements.
- All ratings ANSI/TIA-942 compliant for Rated-1 through Rated-4 data centers.

Fuel Rates

Fuel rates are based on fuel oil of 35° API [16°C (60°F)] gravity having an LHV of 42,780 kJ/kg (18,390 Btu/lb) when used at 29°C (85°F) and weighing 838.9 g/liter (7.001 lbs/U.S. gal.)

www.cat.com/powergeneration

©2019 Caterpillar

All rights reserved.

Materials and specifications are subject to change without notice. The International System of Units (SI) is used in this publication.