



Cat[®] 299D3

COMPACT TRACK LOADER WITH STEEL TRACK UNDERCARRIAGE

FEATURES:

The Cat[®] 299D3 Compact Track Loader, with its vertical lift design, delivers extended reach and lift height for easy truck loading. Its standard, suspended steel track undercarriage provides superior traction, flotation and stability to work in a wide range of applications and underfoot conditions. The 299D3 features the following:

- **Industry leading sealed and pressurized cab option** provides a cleaner and quieter operating environment with excellent Work Tool visibility.
- **Available high-back, heated, air ride seat with seat mounted adjustable joystick controls** makes Cat Compact Track Loaders the industry leader in operator comfort.
- **High performance power train** provides maximum performance and production capability through the Electronic Torque Management system and an electronic hand/foot throttle with decel pedal capability.
- **High Flow XPS hydraulic system** is available for applications that demand maximum hydraulic work tool performance.
- **Electronically controlled Cat C3.8 engine** provides high horsepower and torque while meeting U.S. EPA Tier 4 Final and EU Stage V emission standards.
- **Cat "Intelligent Leveling" system** provides industry leading technology, integration, and available features such as dual direction self level, work tool return to dig, and work tool positioner.
- **Standard fully independent torsion axle suspension** combined with the optional Speed Sensitive Ride Control system improves operation on rough terrain, enabling better load retention, increased productivity and greater operator comfort.
- **Maximize machine capability and control** with the standard Advanced Display providing on-screen adjustments for implement response, hystat response, and creep control, multi-language functionality with customizable layouts, security system, and rearview camera.
- **Ground level access** to all daily service and routine maintenance points helps reduce machine downtime for greater productivity.
- **Broad range of performance matched Cat Work Tool Attachments** make the Cat Compact Track Loader the most versatile machine on the job site.

Specifications

Engine

Engine Model	Cat C3.8 DIT (turbo)	
Gross Power SAE J1995	73 kW	98 hp
Net Power SAE 1349	71 kW	95 hp
Net Power ISO 9249	71 kW	95 hp
Peak Torque at 1,500 rpm SAE J1995	334 N-m	246 lbf-ft
Displacement	3.8 L	232 in ³
Stroke	120 mm	4.7 in
Bore	100 mm	3.9 in

Power Train

Travel Speed (Forward or Reverse):		
One Speed	8.4 km/h	5.2 mph

Hydraulic System

Hydraulic Flow – Standard:			
Loader Hydraulic Pressure	23 000 kPa	3,335 psi	
Loader Hydraulic Flow	86 L/min	23 gal/min	
Hydraulic Power (calculated)	33 kW	44 hp	
Hydraulic Flow – High Flow XPS:			
Maximum Loader Hydraulic Pressure	28 000 kPa	4,061 psi	
Maximum Loader Hydraulic Flow	121 L/min	32 gal/min	
Hydraulic Power (calculated)	57 kW	76 hp	

Cab

ROPS	ISO 3471:2008
FOPS	ISO 3449:2005 Level I



299D3 Compact Track Loader with Steel Track Undercarriage

Weights*

Operating Weight	5637 kg	12,427 lb
------------------	---------	-----------

Service Refill Capacities

Cooling System	16 L	4.1 gal
Diesel Exhaust Fluid (DEF) Tank	19 L	5 gal
Engine Crankcase	13 L	3.5 gal
Fuel Tank	120 L	31.7 gal
Hydraulic System	55 L	14.5 gal
Hydraulic Tank	39 L	10.3 gal

Operating Specifications*

Rated Operating Capacity:		
35% Tipping Load	1750 kg	3,850 lb
50% Tipping Load	2500 kg	5,500 lb
Rated Operating Capacity with Optional Counterweight		
Tipping Load	2620 kg	5,765 lb
Tipping Load	5000 kg	11,000 lb
Breakout Force, Tilt Cylinder	3298 kg	7,270 lb
Breakout Force, Lift Cylinder	2795 kg	6,162 lb
Ground Contact Area (355 mm/14 in track)	1.23 m ²	1,914 in ²
Ground Pressure (355 mm/14 in track)	44.8 kPa	6.5 psi

Noise Level

Inside Cab**	83 dB(A)
Outside Cab***	107 dB(A)

- Cab and Rollover Protective Structures (ROPS) are standard in North America and Europe.

**The declared dynamic operator sound pressure levels per ISO 6396:2008. The measurements were conducted with the cab doors and windows closed and at 70% of the maximum engine cooling fan speed. The sound level may vary at different engine cooling fan speeds.

***The labeled sound power level for the CE marked configurations when measured according to the test procedure and conditions specified in 2000/14/EC.

Air Conditioning System (if equipped)

The air conditioning system on this machine contains the fluorinated greenhouse gas refrigerant R134a (Global Warming Potential = 1430). The system contains 0.81 kg of refrigerant which has a CO₂ equivalent of 1.158 metric tonnes.

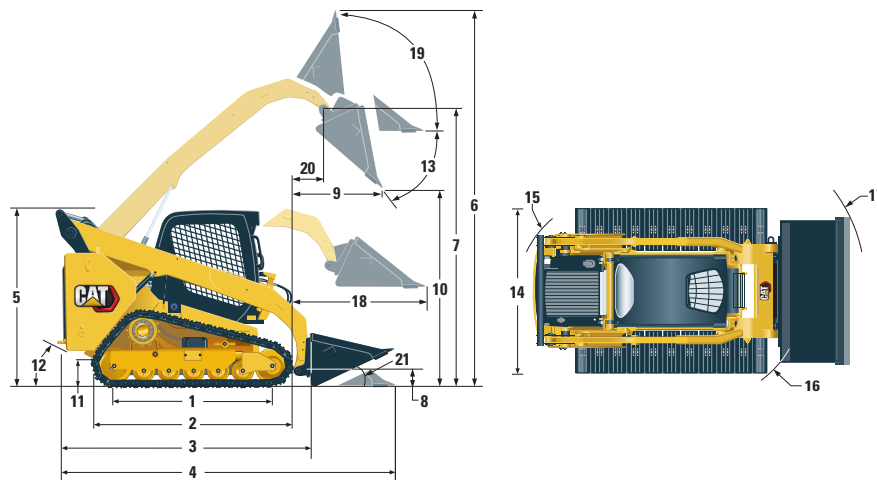

Dimensions*

	mm	in	mm	in
1 Length of Track on Ground	1767	69.6		
2 Overall Length of Track	2270	89.4		
3 Length without Bucket	3189	125.5		
4 Length with Bucket on Ground	3931	154.7		
5 Height to Top of Cab	2125	83.6		
6 Maximum Overall Height	4032	158.7		
7 Bucket Pin Height at Maximum Lift	3208	126.3		
8 Bucket Pin Height at Carry Position	180	7.1		
9 Reach at Maximum Lift and Dump	852	33.6		
10 Clearance at Maximum Lift and Dump	2399	94.5		
11 Ground Clearance	245	9.6		
			12 Departure Angle	33°
			13 Maximum Dump Angle	54°
			14 Vehicle Width (355 mm/14 in steel tracks)	1881 74.1
			15 Turning Radius from Center – Machine Rear	1881 74.0
			16 Turning Radius from Center – Coupler	1476 58.1
			17 Turning Radius from Center – Bucket (racked)	2314 91.1
			18 Maximum Reach with Arms Parallel to Ground	1319 51.9
			19 Rack Back Angle at Maximum Height	81°
			20 Bucket Pin Reach at Maximum Lift	493 19.4
			21 Roll Back Angle	25°

*Operating Weight, Operating Specifications and Dimensions all based on 75 kg (165 lb) operator, all fluids, one speed, 2036 mm (80 in) low profile bucket, 355 mm (14 in) steel tracks, standard flow hydraulics, enclosed cab with glass door, side windows, heater, mechanical suspension seat, advanced display, 850 CCA battery, no optional counterweights and manual quick coupler (unless otherwise noted).

299D3 Compact Track Loader with Steel Track Undercarriage

MANDATORY EQUIPMENT

- Hydraulics, Standard or High Flow XPS
- Quick Coupler, Mechanical or Powered
- Seat Belt, 50 mm (2 in) or 75 mm (3 in)

PERFORMANCE PACKAGE

- Performance Package H1: *Standard Flow (No Self Level)*
- Performance Package H2: *Standard Flow Hydraulics, Dual Direction Electronic Self Level (Raise and Lower), Work Tool Return to Dig, Work Tool Positioner, and Electronic Snubbing (Raise and Lower)*
- Performance Package H3: *High Flow Hydraulics, Dual Direction Electronic Self Level (Raise and Lower), Work Tool Return to Dig, Work Tool Positioner, and Electronic Snubbing (Raise and Lower)*

COMFORT PACKAGE

- Open ROPS (C0): *Static Seat with Foot Throttle (No Headliner, Heater or Door)*
- Open ROPS (C1): *Foot Throttle, Headliner, Cup Holder, and choice of Seat (Mechanical Suspension or High Back, Heated, Air Ride Seat) (No Heater or Door)*
- Enclosed ROPS with Heater (C2): *Foot Throttle, Headliner, Heater and Defroster, Side Windows, Cup Holder, Radio Ready, choice of Seat (Mechanical Suspension or High Back, Heated, Air Ride Seat) and Door (Glass or Polycarbonate)*
- Enclosed ROPS with A/C (C3): *C2 + Air Conditioner*

STANDARD EQUIPMENT

ELECTRICAL

- 12 volt Electrical System
- 100 ampere Alternator
- Ignition Key Start/Stop Switch
- Lights: *Gauge Backlighting, Two Rear Tail Lights, Two Rear Halogen Working Lights, Two Adjustable Front Halogen Lights, Dome Light*
- Backup Alarm
- Heavy Duty Battery, 850 CCA

OPERATOR ENVIRONMENT

- Gauges: *Fuel Level, DEF Level, Hour Meter*
- Operator Warning System Indicators: *Air Filter Restriction, Alternator Output, Armrest Raised/Operator Out of Seat, Engine Coolant Temperature, Engine Oil Pressure, Air Inlet Heater Activation, Hydraulic Filter Restriction, Hydraulic Oil Temperature, Park Brake Engaged, Engine Emission System*
- Adjustable Vinyl Seat
- Fold In Ergonomic Contoured Armrest
- Control Interlock System, when operator leaves seat or armrest raised: *Hydraulic System Disables, Hydrostatic Transmission Disables, Parking Brake Engages*
- ROPS Cab, Open, Tilt Up
- FOPS, Level I
- Top and Rear Windows
- Floor Mat
- Interior Rearview Mirror
- USB Charging Port
- Horn
- Hand (Dial) Throttle, Electronic
- Adjustable Joystick Controls
- Advanced Display With Rearview Camera: *Full Color, 127 mm (5 in) LCD screen; Advanced Multi-operator Security System; On-screen Adjustments for Implement Response, Hystat Response and Creep Control*
- Storage Compartment with Netting

POWER TRAIN

- Cat C3.8, Turbo Diesel Engine, Meeting Tier 4 Final and Stage V Emission Standards
- Air Cleaner, Dual Element, Radial Seal
- S-O-SSM Sampling Valve, Hydraulic Oil
- Filter, Cartridge-type, Hydraulic
- Filter, Canister-type, Fuel and Water Separator
- Radiator/Hydraulic Oil Cooler (side-by-side)
- Spring Applied, Hydraulically Released, Wet Multi Disc Parking Brakes
- Hydrostatic Transmission, Single Speed Travel
- Suspension – Independent Torsion Axles (4)

OTHER

- Engine Enclosure, Lockable
- Extended Life Antifreeze, -37° C (-34° F)
- Machine Tie Down Points (6)
- Support, Lift Arm
- Hydraulic Oil Level Sight Gauge
- Radiator Coolant Level Sight Gauge
- Radiator, Expansion Bottle
- Cat ToughGuard™ Hose
- Auxiliary, Hydraulics, Continuous Flow
- Heavy Duty, Flat Faced Quick Disconnects with Integrated Pressure Release
- Split D-Ring to Route Work Tool Hoses Along Side of Left Lift Arm
- Electrical Outlet, Beacon
- Belly Pan Cleanout
- Variable Speed Demand Fan
- Steel Track (Sealed and Lubricated – SALT) – 355 mm (14.0 in) with Triple Grouser Track Shoes
- Product Link™ PL240, Cellular

299D3 Compact Track Loader with Steel Track Undercarriage

OPTIONAL EQUIPMENT

- External Counterweights
- Beacon, Rotating
- Engine Block Heater – 120V
- Oil, Hydraulic, Cold Operation
- Paint, Custom
- Heavy Duty Battery, 850 CCA, with Battery Disconnect
- Heavy Duty Battery, 1,000 CCA, with Battery Disconnect
- Product Link PL641, Cellular
- Variable Speed Demand Fan with Reversing Functionality
- Speed Sensitive Ride Control
- Bluetooth® Radio with Microphone (AM/FM/Weather Band Receiver with USB and Auxiliary Input Jack)

For more complete information on Cat products, dealer services, and industry solutions, visit us on the web at www.cat.com

© 2021 Caterpillar
All rights reserved

Materials and specifications are subject to change without notice. Featured machines in photos may include additional equipment. See your Cat dealer for available options.

CAT, CATERPILLAR, LET'S DO THE WORK, their respective logos, "Caterpillar Corporate Yellow," the "Power Edge" and Cat "Modern Hex" trade dress as well as corporate and product identity used herein, are trademarks of Caterpillar and may not be used without permission.

AEHQ8201-02 (01-2021)
Replaces AEHQ8201-01
(Am North, EU, APD, ANZP)

