



Cat[®] Hammers

E Series, GC, and GC Silenced Models

Technical Specifications

Not all attachments are available in all regions. Consult your Cat[®] dealer for specific configurations available in your region.

Table of Contents

Specifications	2				
Hydraulic Specifications	3				
Dimensions	4				
Hammer Tool Specifications	6				
Matching	9				
311F9	318D217	326D231	336F44	349F XE58	M317F83
312D2 GC9	318F18	326F32	336F XE46	34959	M318F85
312D210	320D2 GC19	329D234	336 GC48	352F59	M320D295
312F11	320D220	330D235	33649	352F XE60	M320F97
313D2 GC11	320F21	330F36	340D252	35260	M322D2101
313D212	320 GC22	330 GC37	340F53	374F61	M322F110
313D2 LGP13	32023	33039	340F UHD54	M314F62	
313F GC14	323D225	335F CR40	34056	M315D266	
314F15	323F26	336D2 GC41	345 GC57	M315F70	
315F CR15	32328	336D242	349D257	M316F72	
316F16	325F CR30	336D2 XE43	349F58	M317D281	
Additional Options	115				
Autolube	116				

Hammer Technical Specifications

Specifications

Model	Part No.	Linkage	Carrier Weight, Minimum		Carrier Weight, Maximum		Operating Weight, Minimum		Operating Weight, Maximum	
			t	lb	t	lb	kg	lb	kg	lb
H110 GC Top-mount	569-1808	312/313, 315	11	24250.6	16	35273.6	1237	2721.4	1262	2776.4
H110 GC Side-mount	565-6678	312/313	11	24250.6	16	35273.6	837	1841.4	837	1841.4
	569-1810	315	11	24250.6	16	35273.6	868	1909.6	868	1909.6
H110 GC S Top-mount	565-4611	312/313, 315, CW-40, CW-40 S	11	24250.6	16	35273.6	1203	2646.6	1228	2701.6
H110E S Top-mount	355-3817		11	24300.0	18	39700.0	950	2090.0	1080	2376.0
	385-0326		11	24300.0	18	39700.0	950	2090.0	1080	2376.0
	388-4794		11	24300.0	18	39700.0	950	2090.0	1080	2376.0
H115 GC Top-mount	417-8035	312/313, 315	13	28659.8	18	39682.8	1327	2919.4	1388	3053.6
H115 GC Side-mount	417-8088	312/313	13	28659.8	18	39682.8	1183	2602.6	1183	2602.6
	417-8092	315	13	28659.8	18	39682.8	1199	2637.8	1199	2637.8
H115 GC S Top-mount	536-3733	312/313, 315, CW-40, CW-40 S	13	28659.8	18	39682.8	1307	2875.4	1331	2928.2
H115E S Top-mount	355-7065	B, CB	12	26500.0	20	44100.0	1070	2354.0	1460	3212.0
	385-0328	B, CB	12	26500.0	20	44100.0	1070	2354.0	1460	3212.0
	388-4795	B, CB	12	26500.0	20	44100.0	1070	2354.0	1460	3212.0
H120 GC Top-mount	572-0372	B, CB, DB	18	39682.8	25	55115.0	1826	4017.2	1866	4105.2
H120 GC Side-mount	572-0373	B	18	39682.8	25	55115.0	1663	3658.6	1663	3658.6
	572-0374	CB	18	39682.8	25	55115.0	1688	3713.6	1688	3713.6
	572-0375	DB	18	39682.8	25	55115.0	1718	3779.6	1718	3779.6
H120 GC S Top-mount	536-3734	B, CB, DB, CW-40, CW-40 S	18	39682.8	25	55115.0	1754	3858.8	1785	3927.0
H120E S Top-mount	355-7061	B, CB, DB	16	35300.0	27	59500.0	1480	3256.0	1860	4092.0
	385-0329	B, CB, DB	16	35300.0	27	59500.0	1480	3256.0	1860	4092.0
	388-4796	B, CB, DB	16	35300.0	27	59500.0	1480	3256.0	1860	4092.0
H130 GC Top-mount	572-0384	CB, DB	25	55115.0	32	70547.2	2364	5200.8	2384	5244.8
H130 GC Side-mount	572-0385	CB	25	55115.0	32	70547.2	2187	4811.4	2187	4811.4
	572-0386	DB	25	55115.0	32	70547.2	2205	4851.0	2205	4851.0
H130 GC S Top-mount	536-3735	CB, DB, CW-45, CW-45 S, CW-40	25	55115.0	32	70547.2	2451	5392.2	2487	5471.4
H130E S Top-mount	355-7063	B, CB, DB	18	39700.0	36	79400.0	1750	3850.0	2140	4708.0
	385-0330	B, CB, DB	18	39700.0	36	79400.0	1750	3850.0	2140	4708.0
	388-4797	B, CB, DB	18	39700.0	36	79400.0	1750	3850.0	2140	4708.0
H140 GC Top-mount	572-0376	CB, DB, TB	30	66138.0	40	88184.0	3017	6637.4	3074	6762.8
H140 GC S Top-mount	536-3736	CB, DB, TB, CW-45, CW-45 S	30	66138.0	40	88184.0	2981	6558.2	3134	6894.8
H140E S Top-mount	363-0738	CB, DB, TB	24	52900.0	42	92600.0	2410	5302.0	2660	5852.0
	426-4892	CB, DB, TB	24	52900.0	42	92600.0	2410	5302.0	2660	5852.0
	431-0575	CB, DB, TB	24	52900.0	42	92600.0	2410	5302.0	2660	5852.0
	431-0581	CB, DB, TB	24	52900.0	42	92600.0	2410	5302.0	2660	5852.0
H160E S Top-mount	366-5119	DB, TB, UB	32	70600.0	55	121300.0	3230	7106.0	3530	7766.0
	426-4894	DB, TB, UB	32	70600.0	55	121300.0	3230	7106.0	3530	7766.0
	431-0578	DB, TB, UB	32	70600.0	55	121300.0	3230	7106.0	3530	7766.0
	431-0584	DB, TB, UB	32	70600.0	55	121300.0	3230	7106.0	3530	7766.0
H180E S Top-mount	366-5168	TB, UB, VB/VB2	42	92610.0	76	167580.0	3990	8778.0	4340	9548.0
	426-4896	TB, UB, VB/VB2	42	92610.0	76	167580.0	3990	8778.0	4340	9548.0
	431-0580	TB, UB, VB/VB2	42	92610.0	76	167580.0	3990	8778.0	4340	9548.0
	431-0589	TB, UB, VB/VB2	42	92610.0	76	167580.0	3990	8778.0	4340	9548.0

Hammer Technical Specifications

Hydraulic Specifications

Model	Part No.	Energy Class		Blows Per Minute		Rated Flow, Minimum		Rated Flow, Maximum		Operating Pressure, Minimum		Operating Pressure, Maximum		Sound Level
		J	ft-lb	Minimum	Maximum	lpm	gpm	lpm	gpm	kPa	psi	kPa	psi	
H110 GC Top-mount	569-1808	2000	1474.93	450	650	80	21.16	100	26.46	14000	2030	16000	2320	132
H110 GC Side-mount	565-6678	2000	1474.93	450	650	80	21.16	100	26.46	14000	2030	16000	2320	132
	569-1810	2000	1474.93	450	650	80	21.16	100	26.46	14000	2030	16000	2320	132
H110 GC S Top-mount	565-4611	2000	1474.93	450	650	80	21.16	100	26.46	14000	2030	16000	2320	126
H110E S Top-mount	355-3817	2712	2000.00	450	1000	60	15.87	120	31.75	13000	1885	16000	2320	118
	385-0326	2712	2000.00	450	1000	60	15.87	120	31.75	13000	1885	16000	2320	118
	388-4794	2712	2000.00	450	1000	60	15.87	120	31.75	13000	1885	16000	2320	118
H115 GC Top-mount	417-8035	3000	2212.40	450	800	90	23.81	120	31.75	15000	2175	17000	2465	134
H115 GC Side-mount	417-8088	3000	2212.40	450	800	90	23.81	120	31.75	15000	2175	17000	2465	134
	417-8092	3000	2212.40	450	800	90	23.81	120	31.75	15000	2175	17000	2465	134
H115 GC S Top-mount	536-3733	3000	2212.40	450	800	90	23.81	120	31.75	15000	2175	17000	2465	128
H115E S Top-mount	355-7065	4067	3000.00	370	800	70	18.52	130	34.39	13000	1885	15000	2175	117
	385-0328	4067	3000.00	370	800	70	18.52	130	34.39	13000	1885	15000	2175	117
	388-4795	4067	3000.00	370	800	70	18.52	130	34.39	13000	1885	15000	2175	117
H120 GC Top-mount	572-0372	4000	2949.87	400	800	125	33.07	150	39.68	16000	2320	18000	2610	134
H120 GC Side-mount	572-0373	4000	2949.87	400	800	125	33.07	150	39.68	16000	2320	18000	2610	134
	572-0374	4000	2949.87	400	800	125	33.07	150	39.68	16000	2320	18000	2610	134
	572-0375	4000	2949.87	400	800	125	33.07	150	39.68	16000	2320	18000	2610	134
H120 GC S Top-mount	536-3734	4000	2949.87	400	800	125	33.07	151	39.95	16000	2320	18000	2610	130
H120E S Top-mount	355-7061	4745	3500.00	350	620	100	26.46	170	44.97	13000	1885	15000	2175	118
	385-0329	4745	3500.00	350	620	100	26.46	170	44.97	13000	1885	15000	2175	118
	388-4796	4745	3500.00	350	620	100	26.46	170	44.97	13000	1885	15000	2175	118
H130 GC Top-mount	572-0384	6000	4424.80	350	700	160	42.33	190	50.26	16000	2320	18000	2610	132
H130 GC Side-mount	572-0385	6000	4424.80	350	700	160	42.33	190	50.26	16000	2320	18000	2610	132
	572-0386	6000	4424.80	350	700	160	42.33	190	50.26	16000	2320	18000	2610	132
H130 GC S Top-mount	536-3735	6000	4424.80	350	700	161	42.59	191	50.53	16000	2320	18000	2610	128
H130E S Top-mount	355-7063	6101	4500.00	320	600	120	31.75	220	58.20	13000	1885	15000	2175	120
	385-0330	6101	4500.00	320	600	120	31.75	220	58.20	13000	1885	15000	2175	120
	388-4797	6101	4500.00	320	600	120	31.75	220	58.20	13000	1885	15000	2175	120
H140 GC Top-mount	572-0376	7500	5531.00	250	550	180	47.62	220	58.20	16000	2320	18000	2610	136
H140 GC S Top-mount	536-3736	7500	5531.00	250	550	181	47.88	221	58.47	16000	2320	18000	2610	130
H140E S Top-mount	363-0738	8135	6000.00	325	540	160	42.33	230	60.85	13000	1885	16000	2320	120
	426-4892	8135	6000.00	325	540	160	42.33	230	60.85	13000	1885	16000	2320	120
	431-0575	8135	6000.00	325	540	160	42.33	230	60.85	13000	1885	16000	2320	120
	431-0581	8135	6000.00	325	540	160	42.33	230	60.85	13000	1885	16000	2320	120
H160E S Top-mount	366-5119	11524	8500.00	400	505	220	58.20	300	79.37	13000	1885	16000	2320	126
	426-4894	11524	8500.00	400	505	220	58.20	300	79.37	13000	1885	16000	2320	126
	431-0578	11524	8500.00	400	505	220	58.20	300	79.37	13000	1885	16000	2320	126
	431-0584	11524	8500.00	400	505	220	58.20	300	79.37	13000	1885	16000	2320	126
H180E S Top-mount	366-5168	16270	12000.00	275	450	220	58.20	300	79.37	13000	1885	16000	2320	126
	426-4896	16270	12000.00	275	450	220	58.20	300	79.37	13000	1885	16000	2320	126
	431-0580	16270	12000.00	275	450	220	58.20	300	79.37	13000	1885	16000	2320	126
	431-0589	16270	12000.00	275	450	220	58.20	300	79.37	13000	1885	16000	2320	126

Hammer Technical Specifications

Dimensions

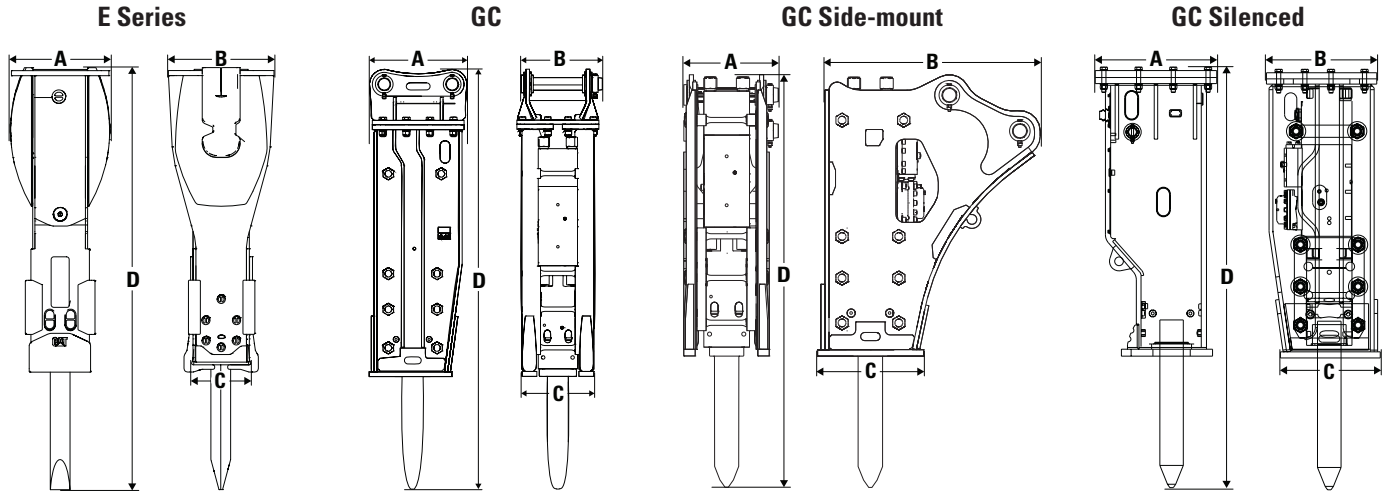

Model	Part No.	(A) Width		(B) Length, Top		(C) Length, Bottom		(D) Height	
		mm	in	mm	in	mm	in	mm	in
H110 GC Top-mount	569-1808	520	20.47	700	27.56	490	19.29	1433	56.42
H110 GC Side-mount	565-6678	350	13.78	1019	40.12	443	17.44	1176	46.30
	569-1810	360	14.17	1072	42.20	456	17.95	1232	48.50
H110 GC S Top-mount	565-4611	520	20.47	700	27.56	400	15.75	1475	58.07
H110E S Top-mount	355-3817	555	21.85	585	23.03			2024	79.69
	385-0326	555	21.85	585	23.03			2024	79.69
	388-4794	555	21.85	585	23.03			2024	79.69
H115 GC Top-mount	417-8035	520	20.47	700	27.56	645	25.39	1430	56.30
H115 GC Side-mount	417-8088	422	16.61	1119	44.06	595	23.43	1354	53.31
	417-8092	422	16.61	1170	46.06	595	23.43	1365	53.74
H115 GC S Top-mount	536-3733	520	20.47	700	27.56	485	19.09	1445	56.89
H115E S Top-mount	355-7065	555	21.85	585	23.03			2191	86.26
	385-0328	555	21.85	585	23.03			2191	86.26
	388-4795	555	21.85	585	23.03			2191	86.26
H120 GC Top-mount	572-0372	525	20.67	632	24.88			2389	94.06
H120 GC Side-mount	572-0373	556	21.89	1270	50.00	620	24.41	2294	90.31
	572-0374	576	22.68	1302	51.26	620	24.41	2294	90.31
	572-0375	610	24.02	1327	52.24	620	24.41	2304	90.71
H120 GC S Top-mount	536-3734	520	20.47	700	27.56	525	20.67	1605	63.19
H120E S Top-mount	355-7061	578	22.76	585	23.03			2372	93.39
	385-0329	578	22.76	585	23.03			2372	93.39
	388-4796	578	22.76	585	23.03			2372	93.39

(continued on next page)

Hammer Technical Specifications

Dimensions (continued)

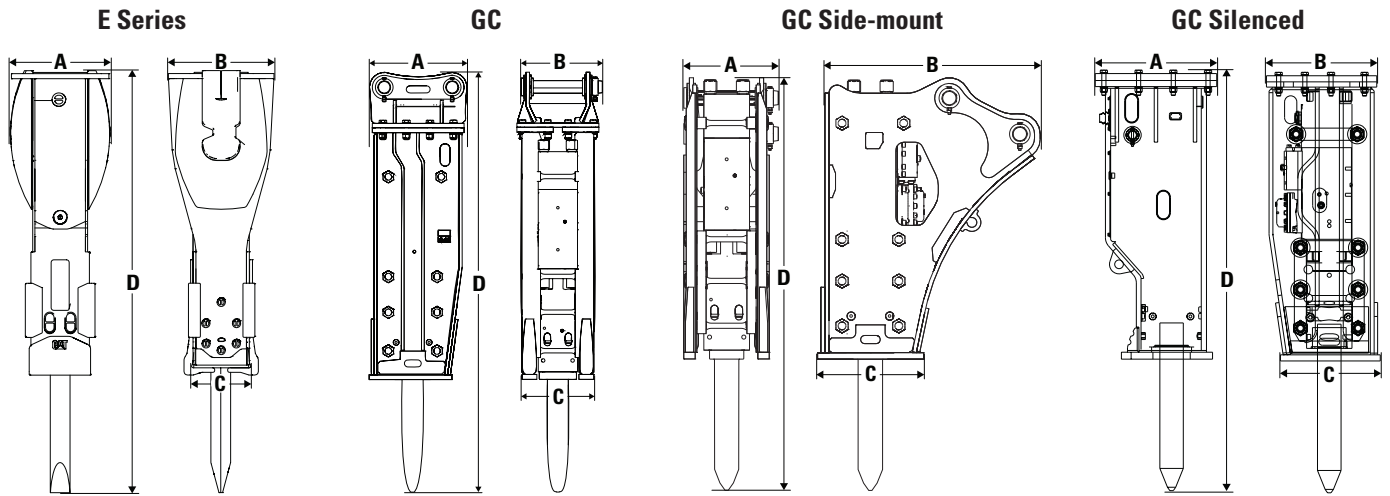

Model	Part No.	(A) Width		(B) Length, Top		(C) Length, Bottom		(D) Height	
		mm	in	mm	in	mm	in	mm	in
H130 GC Top-mount	572-0384	585	23.03	655	25.79			2632	103.62
H130 GC Side-mount	572-0385	580	22.83	1367	53.82	650	25.59	2530	99.61
	572-0386	615	24.21	1367	53.82	650	25.59	2537	99.88
H130 GC S Top-mount	536-3735	660	25.98	830	32.68	563	22.17	1795	70.67
H130E S Top-mount	355-7063	627	24.69	585	23.03			2560	100.79
	385-0330	627	24.69	585	23.03			2560	100.79
	388-4797	627	24.69	585	23.03			2560	100.79
H140 GC Top-mount	572-0376	635	25.00	730	28.74	714	28.11	2798	110.16
H140 GC S Top-mount	536-3736	660	25.98	830	32.68	606	23.86	2025	79.72
H140E S Top-mount	363-0738	670	26.38	585	23.03			2759	108.62
	426-4892	670	26.38	585	23.03			2759	108.62
	431-0575	670	26.38	585	23.03			2759	108.62
	431-0581	670	26.38	585	23.03			2759	108.62
H160E S Top-mount	366-5119	736	28.98	730	28.74			3057	120.35
	426-4894	736	28.98	730	28.74			3057	120.35
	431-0578	736	28.98	730	28.74			3057	120.35
	431-0584	736	28.98	730	28.74			3057	120.35
H180E S Top-mount	366-5168	758	29.84	730	28.74			3257	128.23
	426-4896	758	29.84	730	28.74			3257	128.23
	431-0580	758	29.84	730	28.74			3257	128.23
	431-0589	758	29.84	730	28.74			3257	128.23

Hammer Technical Specifications

Hammer Tool Specifications

Hammer Model	Tool Family	Tool Profile	Part No.	Total Length		Working Length		Diameter, Top		Diameter, Bottom		Weight	
				mm	in	mm	in	mm	in	mm	in	kg	lb
H110 GC	Standard	Blunt	565-4613	950	37.40	550.0	21.65	72.0	2.83	98.0	3.86	52.6	115.98
	Standard	Chisel	565-4615	950	37.40	550.0	21.65	72.0	2.83	98.0	3.86	50.4	111.13
	Standard	Chisel (Forged Tip)	565-4616	950	37.40	550.0	21.65	72.0	2.83	130.0	5.12	50.4	111.13
	Standard	Moil	565-4612	950	37.40	550.0	21.65	72.0	2.83	98.0	3.86	47.6	104.96
	Standard	Pyramidal	565-4614	950	37.40	550.0	21.65	72.0	2.83	98.0	3.86	48.3	106.50
H110 GC S	Standard	Blunt	565-4613	950	37.40	550.0	21.65	72.0	2.83	98.0	3.86	52.6	115.98
	Standard	Chisel	565-4615	950	37.40	550.0	21.65	72.0	2.83	98.0	3.86	50.4	111.13
	Standard	Chisel (Forged Tip)	565-4616	950	37.40	550.0	21.65	72.0	2.83	130.0	5.12	50.0	110.25
	Standard	Moil	565-4612	950	37.40	550.0	21.65	72.0	2.83	98.0	3.86	47.6	104.96
	Standard	Pyramidal	565-4614	950	37.40	550.0	21.65	72.0	2.83	98.0	3.86	48.3	106.50
H110E S	Standard	Blunt	355-5887	890	35.04	496.0	19.53	99.5	3.92	99.5	3.92	53.1	117.07
	Standard	Chisel	355-5882	890	35.04	496.0	19.53	99.5	3.92	99.5	3.92	50.4	111.11
	Standard	Moil	355-5884	890	35.04	496.0	19.53	99.5	3.92	99.5	3.92	50.2	110.67
	Specialty	Long Chisel	373-4914	1000	39.37	606.0	23.86	99.5	3.92	99.5	3.92	57.1	125.88
	Specialty	Long Moil	373-4916	1000	39.37	606.0	23.86	99.5	3.92	99.5	3.92	56.9	125.44
	WearFlex	Blunt	468-8005	890	35.04	496.0	19.53	99.5	3.92	99.5	3.92	53.2	117.29
	WearFlex	Chisel	468-8031	890	35.04	496.0	19.53	99.5	3.92	99.5	3.92	50.4	111.11
	WearFlex	Moil	468-8013	890	35.04	496.0	19.53	99.5	3.92	99.5	3.92	50.3	110.89
H115 GC	Standard	Blunt	566-1533	1100	43.31	700.0	27.56	120.0	4.72	120.0	4.72	95.3	210.14
	Standard	Chisel	566-1536	1100	43.31	700.0	27.56	120.0	4.72	120.0	4.72	90.5	199.55
	Standard	Chisel (Forged Tip)	569-4710	1100	43.31	700.0	27.56	120.0	4.72	159.0	6.26	95.1	209.63
	Standard	Moil	566-1535	1100	43.31	700.0	27.56	120.0	4.72	120.0	4.72	85.4	188.31
	Standard	Pyramidal	566-1534	1100	43.31	700.0	27.56	120.0	4.72	120.0	4.72	89.0	196.25
H115 GC S	Standard	Blunt	566-1533	1100	43.31	700.0	27.56	120.0	4.72	120.0	4.72	95.3	210.14
	Standard	Chisel	566-1536	1100	43.31	700.0	27.56	120.0	4.72	120.0	4.72	90.5	199.55
	Standard	Chisel (Forged Tip)	569-4710	1100	43.31	700.0	27.56	120.0	4.72	159.0	6.26	95.1	209.63
	Standard	Moil	566-1535	1100	43.31	700.0	27.56	120.0	4.72	120.0	4.72	85.4	188.31
	Standard	Pyramidal	566-1534	1100	43.31	700.0	27.56	120.0	4.72	120.0	4.72	89.0	196.25
H115E S	Standard	Blunt	355-5880	980	38.58	549.0	21.61	109.5	4.31	109.5	4.31	69.6	153.44
	Standard	Chisel	355-5878	980	38.58	549.0	21.61	109.5	4.31	109.5	4.31	65.8	145.06
	Standard	Moil	355-5879	980	38.58	549.0	21.61	109.5	4.31	109.5	4.31	65.7	144.84
	Specialty	Long Chisel	373-4917	1080	42.52	649.0	25.55	109.5	4.31	109.5	4.31	73.2	161.38
	Specialty	Long Moil	373-4918	1080	42.52	649.0	25.55	109.5	4.31	109.5	4.31	73.0	160.94
	WearFlex	Blunt	468-8006	980	38.58	549.0	21.61	109.5	4.31	109.5	4.31	69.7	153.66
	WearFlex	Chisel	468-8032	980	38.58	549.0	21.61	109.5	4.31	109.5	4.31	65.9	145.28
	WearFlex	Moil	468-8014	980	38.58	549.0	21.61	109.5	4.31	109.5	4.31	65.7	144.84

(continued on next page)

Hammer Technical Specifications

Hammer Tool Specifications (continued)

Hammer Model	Tool Family	Tool Profile	Part No.	Total Length		Working Length		Diameter, Top		Diameter, Bottom		Weight	
				mm	in	mm	in	mm	in	mm	in	kg	lb
H120 GC	Standard	Blunt	565-8758	1200	47.24	750.0	29.53	135.0	5.31	135.0	5.31	118.0	260.19
	Standard	Chisel	565-8761	1200	47.24	750.0	29.53	135.0	5.31	135.0	5.31	116.0	255.78
	Standard	Chisel (Forged Tip)	569-4711	1200	47.24	750.0	29.53	135.0	5.31	180.0	5.31	132.0	291.06
	Standard	Moil	565-8760	1200	47.24	750.0	29.53	135.0	5.31	135.0	5.31	116.0	255.78
	Standard	Pyramidal	565-8759	1200	47.24	750.0	29.53	135.0	5.31	135.0	5.31	115.0	253.58
H120 GC S	Standard	Blunt	565-8758	1200	47.24	750.0	29.53	135.0	5.31	135.0	5.31	118.0	260.19
	Standard	Chisel	565-8761	1200	47.24	750.0	29.53	135.0	5.31	135.0	5.31	116.0	255.78
	Standard	Chisel (Forged Tip)	569-4711	1200	47.24	750.0	29.53	135.0	5.31	180.0	5.31	132.0	291.06
	Standard	Moil	565-8760	1200	47.24	750.0	29.53	135.0	5.31	135.0	5.31	116.0	255.78
	Standard	Pyramidal	565-8759	1200	47.24	750.0	29.53	135.0	5.31	135.0	5.31	115.0	253.58
H120E S	Standard	Blunt	355-5867	1075	42.32	597.0	23.50	119.5	4.70	119.5	4.70	91.6	201.94
	Standard	Chisel	355-5865	1075	42.32	597.0	23.50	119.5	4.70	119.5	4.70	86.3	190.26
	Standard	Moil	355-5866	1075	42.32	597.0	23.50	119.5	4.70	119.5	4.70	86.2	190.04
	Specialty	Long Chisel	373-4919	1175	46.26	697.0	27.44	119.5	4.70	119.5	4.70	95.1	209.66
	Specialty	Long Moil	373-4920	1175	46.26	697.0	27.44	119.5	4.70	119.5	4.70	95.0	209.44
	WearFlex	Blunt	468-8007	1075	42.32	597.0	23.50	119.5	4.70	119.5	4.70	91.6	201.94
	WearFlex	Chisel	468-8033	1075	42.32	597.0	23.50	119.5	4.70	119.5	4.70	86.4	190.48
	WearFlex	Moil	468-8017	1075	42.32	597.0	23.50	119.5	4.70	119.5	4.70	86.3	190.26
H130 GC	Standard	Blunt	565-8762	1300	51.18	800.0	31.50	150.0	5.91	150.0	5.91	173.0	381.47
	Standard	Chisel	565-8767	1300	51.18	800.0	31.50	150.0	5.91	150.0	5.91	165.0	363.83
	Standard	Chisel (Forged Tip)	569-4712	1300	51.18	800.0	31.50	150.0	5.91	197.0	5.91	175.0	385.88
	Standard	Moil	565-8766	1300	51.18	800.0	31.50	150.0	5.91	150.0	5.91	165.0	363.83
	Standard	Pyramidal	565-8764	1300	51.18	800.0	31.50	150.0	5.91	150.0	5.91	161.0	355.01
H130 GC S	Standard	Blunt	565-8762	1300	51.18	800.0	31.50	150.0	5.91	150.0	5.91	173.0	381.47
	Standard	Chisel	565-8767	1300	51.18	800.0	31.50	150.0	5.91	150.0	5.91	165.0	363.83
	Standard	Chisel (Forged Tip)	569-4712	1300	51.18	800.0	31.50	150.0	5.91	197.0	5.91	175.0	385.88
	Standard	Moil	565-8766	1300	51.18	800.0	31.50	150.0	5.91	150.0	5.91	165.0	363.83
	Standard	Pyramidal	565-8764	1300	51.18	800.0	31.50	150.0	5.91	150.0	5.91	161.0	355.01
H130E S	Standard	Blunt	355-5877	1150	45.28	646.6	25.46	130.0	5.12	130.0	5.12	115.3	254.19
	Standard	Chisel	355-5868	1150	45.28	646.6	25.46	130.0	5.12	130.0	5.12	108.4	238.98
	Standard	Moil	355-5876	1150	45.28	646.6	25.46	130.0	5.12	130.0	5.12	108.2	238.54
	Specialty	Hard Rock Chisel	373-4923	1150	45.28	646.6	25.46	130.0	5.12	129.5	5.10	104.7	230.82
	Specialty	Long Chisel	373-4921	1250	49.21	746.6	29.39	130.0	5.12	129.5	5.10	118.7	261.69
	Specialty	Long Moil	373-4922	1250	49.21	746.6	29.39	130.0	5.12	129.5	5.10	118.5	261.25
	WearFlex	Blunt	468-8008	1150	45.28	646.6	25.46	130.0	5.12	130.0	5.12	115.4	254.41
	WearFlex	Chisel	468-8034	1150	45.28	646.6	25.46	130.0	5.12	130.0	5.12	108.5	239.20
	WearFlex	Moil	468-8021	1150	45.28	646.6	25.46	130.0	5.12	130.0	5.12	108.3	238.76

(continued on next page)

Hammer Technical Specifications

Hammer Tool Specifications (continued)

Hammer Model	Tool Family	Tool Profile	Part No.	Total Length		Working Length		Diameter, Top		Diameter, Bottom		Weight	
				mm	in	mm	in	mm	in	mm	in	kg	lb
H140 GC	Standard	Blunt	566-1537	1400	55.12	735.0	28.94	120.0	4.72	153.0	6.02	172.0	379.26
	Standard	Chisel	566-1540	1400	55.12	735.0	28.94	120.0	4.72	153.0	6.02	178.0	392.49
	Standard	Chisel (Forged Tip)	569-4713	1400	55.12	735.0	28.94	120.0	4.72	203.0	6.02	190.0	418.95
	Standard	Moil	566-1539	1400	55.12	735.0	28.94	120.0	4.72	153.0	6.02	176.0	388.08
	Standard	Pyramidal	566-1538	1400	55.12	735.0	28.94	120.0	4.72	153.0	6.02	172.0	379.26
H140 GC S	Standard	Blunt	566-1537	1400	55.12	735.0	28.94	120.0	4.72	153.0	6.02	172.0	379.26
	Standard	Chisel	566-1540	1400	55.12	735.0	28.94	120.0	4.72	153.0	6.02	178.0	392.49
	Standard	Chisel (Forged Tip)	569-4713	1400	55.12	735.0	28.94	120.0	4.72	203.0	6.02	190.0	418.95
	Standard	Moil	566-1539	1400	55.12	735.0	28.94	120.0	4.72	153.0	6.02	176.0	388.08
	Standard	Pyramidal	566-1538	1400	55.12	735.0	28.94	120.0	4.72	153.0	6.02	172.0	379.26
H140E S	Standard	Blunt	374-3622	1200	47.24	651.8	25.66	139.5	5.49	139.5	5.49	140.0	308.65
	Standard	Chisel	374-3620	1200	47.24	651.8	25.66	139.5	5.49	139.5	5.49	131.0	288.81
	Standard	Moil	374-3621	1200	47.24	651.8	25.66	139.5	5.49	139.5	5.49	130.3	287.26
	Specialty	Hard Rock Chisel	423-1654	1200	47.24	651.8	25.66	139.5	5.49	139.5	5.49	127.3	280.65
	Specialty	Long Chisel	423-1659	1350	53.15	801.8	31.57	139.5	5.49	139.5	5.49	149.1	328.71
	Specialty	Long Moil	423-1660	1350	53.15	801.8	31.57	139.5	5.49	139.5	5.49	149.2	328.93
	Specialty	Super Blunt	423-1662	1250	49.21	701.8	27.63	139.5	5.49	150.0	5.91	157.4	347.01
	WearFlex	Blunt	468-8010	1200	47.24	651.8	25.66	139.5	5.49	139.5	5.49	140.1	308.87
	WearFlex	Chisel	468-8035	1200	47.24	651.8	25.66	139.5	5.49	139.5	5.49	131.2	289.25
	WearFlex	Moil	468-8023	1200	47.24	651.8	25.66	139.5	5.49	139.5	5.49	131.2	289.25
H160E S	Standard	Blunt	374-3625	1400	55.12	753.0	29.65	155.5	6.12	159.5	6.28	211.0	465.17
	Standard	Chisel	374-3623	1400	55.12	753.0	29.65	155.5	6.12	159.5	6.28	196.8	433.87
	Standard	Moil	374-3624	1400	55.12	753.0	29.65	155.5	6.12	159.5	6.28	197.6	435.63
	Specialty	Hard Rock Chisel	423-1663	1400	55.12	753.0	29.65	155.5	6.12	159.5	6.28	190.9	420.86
	Specialty	Long Chisel	423-1664	1530	60.24	883.0	34.76	155.5	6.12	159.5	6.28	217.2	478.84
	Specialty	Long Moil	423-1665	1530	60.24	883.0	34.76	155.5	6.12	159.5	6.28	218.0	480.61
	Specialty	Super Blunt	423-1667	1450	57.09	803.0	31.61	155.5	6.12	175.0	6.89	241.7	532.86
	WearFlex	Blunt	468-8011	1400	55.12	753.0	29.65	155.5	6.12	159.5	6.28	211.0	465.17
	WearFlex	Chisel	468-8036	1400	55.12	753.0	29.65	155.5	6.12	159.5	6.28	196.8	433.87
	WearFlex	Moil	468-8029	1400	55.12	753.0	29.65	155.5	6.12	159.5	6.28	197.6	435.63
H180E S	Standard	Blunt	374-3629	1500	59.06	760.5	29.94	174.5	6.87	179.5	7.07	287.1	632.95
	Standard	Chisel	374-3626	1500	59.06	760.5	29.94	174.5	6.87	179.5	7.07	266.2	586.87
	Standard	Moil	374-3627	1500	59.06	760.5	29.94	174.5	6.87	179.5	7.07	268.3	591.50
	Specialty	Hard Rock Chisel	423-1668	1500	59.06	760.5	29.94	174.5	6.87	179.5	7.07	257.7	568.13
	Specialty	Super Blunt	423-1669	1550	61.02	810.5	31.91	174.5	6.87	202.0	7.95	335.0	738.55
	WearFlex	Blunt	468-8012	1500	59.06	760.5	29.94	174.5	6.87	179.5	7.07	287.1	632.95
	WearFlex	Chisel	468-8038	1500	59.06	760.5	29.94	174.5	6.87	179.5	7.07	266.2	586.87
	WearFlex	Moil	468-8030	1500	59.06	760.5	29.94	174.5	6.87	179.5	7.07	268.3	591.50

Matching – Tracked Excavators

Match
 * Working Range Front Only
 † Allowed Usage on Machine Less Than 50%
 No Match

311F

Pin-on

Undercarriage	L	
Counterweight	—	
Boom Type	Reach	
Stick Length	2.25 m (7'5")	2.80 m (9'2")
H110GC		✓
H110GC S	✓	✓
H110E S	✓	✓
H115E S	✓	✓

Cat Pin Grabber Coupler

Undercarriage	L	
Counterweight	—	
Boom Type	Reach	
Stick Length	2.25 m (7'5")	2.80 m (9'2")
H110GC S	✓	
H110E S	✓	✓
H115E S	✓	

CW-20 S Dedicated Coupler

Undercarriage	L
Counterweight	—
Boom Type	Reach
Stick Length	2.25 m (7'5")
H110E S	✓
H115E S	✓

CW-20 Dedicated Coupler

Undercarriage	L
Counterweight	—
Boom Type	Reach
Stick Length	2.25 m (7'5")
H110E S	✓
H115E S	✓

312D2 GC

Pin-on

Undercarriage	—
Counterweight	—
Boom Type	Reach
Stick Length	2.50 m (8'2")
H110E S	✓
H115E S	✓

Cat Pin Grabber Coupler

Undercarriage	—
Counterweight	—
Boom Type	Reach
Stick Length	2.50 m (8'2")
H110E S	✓
H115E S	✓

(continued on next page)

Hammer Technical Specifications

Matching – Tracked Excavators (continued)

Match
 * Working Range Front Only
 † Allowed Usage on Machine Less Than 50%
 No Match

312D2

Pin-on

Undercarriage	—		L	
Counterweight	—		—	
Boom Type	Reach		Reach	
Stick Length	2.50 m (8'2")	3.00 m (9'10")	2.50 m (8'2")	3.00 m (9'10")
H110GC	✓	✓	✓	✓
H110GC, side mount			✓	✓
H110GC S	✓	✓	✓	✓
H110E S	✓	✓	✓	✓
H115 GC	✓	✓	✓	✓
H115 GC S	✓	✓	✓	✓
H115E S	✓	✓	✓	✓

Cat Pin Grabber Coupler

Undercarriage	—		L	
Counterweight	—		—	
Boom Type	Reach		Reach	
Stick Length	2.50 m (8'2")	3.00 m (9'10")	2.50 m (8'2")	3.00 m (9'10")
H110GC	✓	✓	✓	✓
H110GC, side mount			✓	✓
H110GC S	✓	✓	✓	✓
H110E S	✓	✓	✓	✓
H115 GC	✓*		✓	
H115 GC S	✓		✓	✓*
H115E S	✓	✓	✓	✓

CW-20 S Dedicated Coupler

Undercarriage	L
Counterweight	—
Boom Type	Reach
Stick Length	2.50 m (8'2")
H110GC	✓
H110GC S	✓
H110E S	✓
H115 GC	✓*
H115 GC S	✓
H115E S	✓

CW-20 Dedicated Coupler

Undercarriage	L
Counterweight	—
Boom Type	Reach
Stick Length	2.50 m (8'2")
H110GC	✓
H110GC S	✓
H110E	✓
H115 GC	✓
H115 GC	✓
H115E	✓

(continued on next page)

Matching – Tracked Excavators (continued)

Match
 Working Range Front Only
 Allowed Usage on Machine Less Than 50%
 No Match

312F

Pin-on

Undercarriage	—					
Counterweight	—					
Boom Type	Reach				VA	
Stick Length	2.10 m (6'11")	2.50 m (8'2")	2.80 m (9'2")	3.00 m (9'10")	2.10 m (6'11")	2.50 m (8'2")
H110E S	✓	✓	✓	✓	✓	✓
H115 GC S	✓	✓	✓	✓	✓	✓
H115E S	✓	✓	✓	✓	✓	

Cat Pin Grabber Coupler

Undercarriage	—					
Counterweight	—					
Boom Type	Reach				VA	
Stick Length	2.10 m (6'11")	2.50 m (8'2")	2.80 m (9'2")	3.00 m (9'10")	2.10 m (6'11")	2.50 m (8'2")
H110E S	✓	✓	✓	✓	✓	✓
H115 GC S	✓	✓	✓	✓*		
H115E S	✓	✓	✓	✓		

CW-20 S Dedicated Coupler

Undercarriage	—					
Counterweight	—					
Boom Type	Reach				VA	
Stick Length	2.10 m (6'11")	2.50 m (8'2")	2.80 m (9'2")	3.00 m (9'10")	2.10 m (6'11")	
H110E S	✓	✓	✓	✓	✓	
H115 GC S	✓	✓	✓*			
H115E S	✓	✓	✓	✓		

CW-20 Dedicated Coupler

Undercarriage	—					
Counterweight	—					
Boom Type	Reach				VA	
Stick Length	2.10 m (6'11")	2.50 m (8'2")	2.80 m (9'2")	3.00 m (9'10")	2.10 m (6'11")	2.50 m (8'2")
H110E S	✓	✓	✓	✓	✓	✓
H115 GC	✓	✓	✓	✓*		
H115E S	✓	✓	✓	✓		

313D2 GC

Pin-on

Undercarriage	—
Counterweight	—
Boom Type	Reach
Stick Length	2.50 m (8'2")
H110GC	✓
H110GC, side mount	✓
H110GC S	✓
H110E S	✓
H115 GC	✓
H115 GC S	✓
H115E S	✓

(continued on next page)

Hammer Technical Specifications

Matching – Tracked Excavators *(continued)*

Match
 Working Range Front Only
 Allowed Usage on Machine Less Than 50%
 No Match

313D2 GC *(continued)*

Cat Pin Grabber Coupler

Undercarriage	—
Counterweight	—
Boom Type	Reach
Stick Length	2.50 m (8'2")
H110GC	✓
H110GC, side mount	✓
H110GC S	✓
H110E S	✓
H115 GC S	✓*
H115E S	✓

313D2

Pin-on

Undercarriage	—	L
Counterweight	—	—
Boom Type	Reach HD	Reach HD
Stick Length	2.50 m HD (8'2")	2.50 m HD (8'2")
H110GC	✓	✓
H110GC, side mount	✓	✓
H110GC S	✓	✓
H110E S	✓	✓
H115 GC	✓	✓
H115 GC S	✓	✓
H115E S	✓	✓

Cat Pin Grabber Coupler

Undercarriage	—	L
Counterweight	—	—
Boom Type	Reach HD	Reach HD
Stick Length	2.50 m HD (8'2")	2.50 m HD (8'2")
H110GC	✓	✓
H110GC, side mount	✓	✓
H110GC S	✓	✓
H110E S	✓	✓
H115 GC	✓*	✓*
H115 GC S	✓	✓
H115E S	✓	✓

(continued on next page)

Matching – Tracked Excavators *(continued)*

Match
 * Working Range Front Only
 † Allowed Usage on Machine Less Than 50%
 No Match

313D2 *(continued)*

CW-20 S Dedicated Coupler

Undercarriage	L
Counterweight	—
Boom Type	Reach HD
Stick Length	2.50 m HD (8'2")
H110GC	✓
H110GC S	✓
H110E S	✓
H115 GC S	✓*
H115E S	✓

CW-20 Dedicated Coupler

Undercarriage	L
Counterweight	—
Boom Type	Reach HD
Stick Length	2.50 m HD (8'2")
H110GC	✓
H110GC S	✓
H110E S	✓
H115 GC	✓*
H115 GC S	✓
H115E S	✓

313D2 LGP

Pin-on

Undercarriage	L	
Counterweight	—	
Boom Type	Reach HD	
Stick Length	2.50 m HD (8'2")	3.00 m (9'10")
H110GC	✓	✓
H110GC S	✓	✓
H110E S	✓	✓
H115 GC	✓	✓
H115 GC S	✓	✓
H115E S	✓	✓

(continued on next page)

Hammer Technical Specifications

Matching – Tracked Excavators *(continued)*

Match
 * Working Range Front Only
 † Allowed Usage on Machine Less Than 50%
 No Match

313F GC

Pin-on

Undercarriage	L		L with Blade	
Counterweight	—		—	
Boom Type	Reach		Reach	
Stick Length	2.50 m (8'2")	3.00 m (9'10")	2.50 m (8'2")	3.00 m (9'10")
H110GC	✓	✓	✓	✓
H110GC S	✓	✓	✓	✓
H110E S	✓	✓	✓	✓
H115E S	✓	✓	✓	✓

Cat Pin Grabber Coupler

Undercarriage	L		L with Blade	
Counterweight	—		—	
Boom Type	Reach		Reach	
Stick Length	2.50 m (8'2")	3.00 m (9'10")	2.50 m (8'2")	3.00 m (9'10")
H110GC	✓	✓	✓	✓
H110GC S	✓	✓	✓	✓
H110E S	✓	✓	✓	✓
H115E S	✓	✓	✓	✓

CW-20 S Dedicated Coupler

Undercarriage	L		L with Blade	
Counterweight	—		—	
Boom Type	Reach		Reach	
Stick Length	2.50 m (8'2")	3.00 m (9'10")	2.50 m (8'2")	3.00 m (9'10")
H110GC S	✓	✓	✓	✓
H110E S	✓	✓	✓	✓
H115E S	✓	✓	✓	✓

CW-20 Dedicated Coupler

Undercarriage	L		L with Blade	
Counterweight	—		—	
Boom Type	Reach		Reach	
Stick Length	2.50 m (8'2")	3.00 m (9'10")	2.50 m (8'2")	3.00 m (9'10")
H110GC S	✓	✓	✓	✓
H110E S	✓	✓	✓	✓
H115E S	✓	✓	✓	✓

(continued on next page)

Matching – Tracked Excavators (continued)

Match
 Working Range Front Only
 Allowed Usage on Machine Less Than 50%
 No Match

314F

Pin-on

Undercarriage	L					
Counterweight	—					
Boom Type	Reach					VA
Stick Length	2.10 m (6'11")	2.50 m (8'2")	2.80 m (9'2")	3.00 m (9'10")	3.00 m TR (9'10")	2.50 m (8'2")
H110E S	✓	✓	✓	✓	✓	✓
H115 GC		✓	✓	✓	✓	
H115 GC S	✓	✓	✓	✓	✓	✓
H115E S		✓	✓	✓	✓	✓

Cat Pin Grabber Coupler

Undercarriage	L					
Counterweight	—					
Boom Type	Reach					VA
Stick Length	2.10 m (6'11")	2.50 m (8'2")	2.80 m (9'2")	3.00 m (9'10")	3.00 m TR (9'10")	2.50 m (8'2")
H110E S	✓	✓	✓	✓	✓	✓
H115 GC		✓	✓	✓*	✓*	
H115 GC S		✓	✓	✓	✓*	
H115E S		✓	✓	✓	✓	

CW-20 S Dedicated Coupler

Undercarriage	L		
Counterweight	—		
Boom Type	Reach		VA
Stick Length	2.50 m (8'2")	3.00 m (9'10")	2.50 m (8'2")
H110E S	✓	✓	✓
H115 GC S	✓	✓*	
H115E S	✓	✓	

CW-20 Dedicated Coupler

Undercarriage	L			
Counterweight	—			
Boom Type	Reach			VA
Stick Length	2.10 m (6'11")	2.50 m (8'2")	3.00 m (9'10")	2.50 m (8'2")
H110E S	✓	✓	✓	✓
H115 GC		✓	✓*	
H115E S		✓	✓	

315F CR

Pin-on

Undercarriage	L				
Counterweight	—				
Boom Type	Reach				VA
Stick Length	2.50 m (8'2")	2.80 m (9'2")	3.00 m (9'10")	3.00 m TR (9'10")	2.10 m (6'11")
H110E S	✓	✓	✓	✓	✓
H115 GC	✓	✓	✓	✓	
H115 GC S	✓	✓	✓	✓	✓
H115E S	✓	✓	✓	✓	✓

(continued on next page)

Hammer Technical Specifications

Matching – Tracked Excavators *(continued)*

Match
 Working Range Front Only
 Allowed Usage on Machine Less Than 50%
 No Match

315F CR *(continued)*

Cat Pin Grabber Coupler

Undercarriage	L				
Counterweight	—				
Boom Type	Reach				VA
Stick Length	2.50 m (8'2")	2.80 m (9'2")	3.00 m (9'10")	3.00 m TR (9'10")	2.10 m (6'11")
H110E S	✓	✓	✓	✓	✓
H115 GC	✓	✓	✓*	✓*	
H115 GC S	✓	✓	✓	✓*	
H115E S	✓	✓	✓	✓	✓

CW-20 S Dedicated Coupler

Undercarriage	L		
Counterweight	—		
Boom Type	Reach		VA
Stick Length	2.50 m (8'2")	3.00 m (9'10")	2.10 m (6'11")
H110E S	✓	✓	✓
H115 GC S		✓*	
H115E S	✓	✓	✓

CW-20 Dedicated Coupler

Undercarriage	L		
Counterweight	—		
Boom Type	Reach		VA
Stick Length	2.50 m (8'2")	3.00 m (9'10")	2.10 m (6'11")
H110E S	✓	✓	✓
H115 GC	✓	✓*	
H115E S	✓	✓	✓

316F

Pin-on

Undercarriage	L					
Counterweight	—					
Boom Type	Reach				VA	
Stick Length	2.25 m (7'5")	2.60 m (8'6")	2.90 m (9'6")	3.10 m (10'2")	2.25 m (7'5")	2.60 m (8'6")
H110E S	✓	✓	✓	✓	✓	✓
H115 GC		✓	✓	✓		
H115 GC S	✓	✓	✓	✓	✓	✓
H115E S	✓	✓	✓	✓	✓	✓
H120E S	✓	✓	✓	✓	✓	✓

(continued on next page)

Matching – Tracked Excavators *(continued)*

Match
 * Working Range Front Only
 † Allowed Usage on Machine Less Than 50%
 No Match

316F *(continued)*

Cat Pin Grabber Coupler

Undercarriage	L					
Counterweight	—					
Boom Type	Reach				VA	
Stick Length	2.25 m (7'5")	2.60 m (8'6")	2.90 m (9'6")	3.10 m (10'2")	2.25 m (7'5")	2.60 m (8'6")
H110E S	✓	✓	✓	✓	✓	✓
H115 GC		✓	✓	✓		
H115 GC S	✓	✓	✓	✓	✓	✓
H115E S	✓	✓	✓	✓	✓	✓
H120E S	✓	✓	✓*			

CW-30 S Dedicated Coupler

Undercarriage	L					
Counterweight	—					
Boom Type	Reach				VA	
Stick Length	2.25 m (7'5")	2.60 m (8'6")	2.90 m (9'6")	2.25 m (7'5")	2.60 m (8'6")	
H110E S	✓	✓	✓	✓	✓	
H115 GC S	✓	✓	✓	✓	✓	
H115E S	✓	✓	✓	✓	✓	
H120E S	✓	✓	✓			

CW-30 Dedicated Coupler

Undercarriage	L					
Counterweight	—					
Boom Type	Reach				VA	
Stick Length	2.25 m (7'5")	2.60 m (8'6")	2.90 m (9'6")	2.25 m (7'5")	2.60 m (8'6")	
H110E S	✓	✓	✓	✓	✓	
H115 GC S	✓	✓	✓	✓	✓	
H115E S	✓	✓	✓	✓	✓	
H120E S	✓	✓	✓			

318D2

Pin-on

Undercarriage	L				
Counterweight	—				
Boom Type	Reach		Reach HD		
Stick Length	2.60 m (8'6")	2.90 m (9'6")	2.60 m HD (8'6")	2.90 m (9'6")	
H115 GC	✓	✓	✓	✓	
H115 GC S	✓	✓	✓	✓	
H115E S	✓	✓	✓	✓	
H120E S	✓	✓	✓	✓	

(continued on next page)

Hammer Technical Specifications

Matching – Tracked Excavators *(continued)*

Match
 Working Range Front Only
 Allowed Usage on Machine Less Than 50%
 No Match

318D2 *(continued)*

Cat Pin Grabber Coupler

Undercarriage	L			
Counterweight	—			
Boom Type	Reach		Reach HD	
Stick Length	2.60 m (8'6")	2.90 m (9'6")	2.60 m HD (8'6")	2.90 m (9'6")
H115 GC	✓	✓	✓	✓
H115 GC S	✓	✓	✓	✓
H115E S	✓	✓	✓	✓
H120E S	✓	✓*	✓*	✓*

CW-30 S Dedicated Coupler

Undercarriage	L
Counterweight	—
Boom Type	Reach
Stick Length	2.60 m (8'6")
H115 GC	✓
H115 GC S	✓
H115E S	✓
H120E S	✓

CW-30 Dedicated Coupler

Undercarriage	L
Counterweight	—
Boom Type	Reach
Stick Length	2.60 m (8'6")
H115 GC	✓
H115 GC S	✓
H115E S	✓
H120E S	✓

318F

Pin-on

Undercarriage	L					
Counterweight	—					
Boom Type	Reach				VA	
Stick Length	2.25 m (7'5")	2.60 m (8'6")	2.90 m (9'6")	3.10 m (10'2")	2.25 m (7'5")	2.60 m (8'6")
H115 GC			✓	✓		
H115 GC S	✓	✓	✓	✓	✓	✓
H115E S	✓	✓	✓	✓	✓	✓
H120E S	✓	✓	✓	✓	✓	✓
H130E S	✓	✓	✓	✓		

(continued on next page)

Hammer Technical Specifications

Matching – Tracked Excavators (continued)

Match
 Working Range Front Only
 Allowed Usage on Machine Less Than 50%
 No Match

318F (continued)

Cat Pin Grabber Coupler

Undercarriage	L					
Counterweight	—					
Boom Type	Reach				VA	
Stick Length	2.25 m (7'5")	2.60 m (8'6")	2.90 m (9'6")	3.10 m (10'2")	2.25 m (7'5")	2.60 m (8'6")
H115 GC			✓	✓		
H115 GC S	✓	✓	✓	✓	✓	✓
H115E S	✓	✓	✓	✓	✓	✓
H120E S	✓	✓	✓	✓*	✓	✓
H130E S	✓	✓*	✓*			

CW-30 S Dedicated Coupler

Undercarriage	L					
Counterweight	—					
Boom Type	Reach				VA	
Stick Length	2.25 m (7'5")	2.60 m (8'6")	2.90 m (9'6")	3.10 m (10'2")	2.25 m (7'5")	2.60 m (8'6")
H115 GC S	✓	✓	✓	✓	✓	✓
H115E S	✓	✓	✓	✓	✓	✓
H120E S	✓	✓	✓	✓		
H130E S	✓	✓*	✓*			

CW-30 Dedicated Coupler

Undercarriage	L					
Counterweight	—					
Boom Type	Reach				VA	
Stick Length	2.25 m (7'5")	2.60 m (8'6")	2.90 m (9'6")	3.10 m (10'2")	2.25 m (7'5")	2.60 m (8'6")
H115 GC S	✓	✓	✓	✓	✓	✓
H115E S	✓	✓	✓	✓	✓	✓
H120E S	✓	✓	✓	✓	✓	✓
H130E S	✓	✓*	✓*			

320D2 GC

Pin-on

Undercarriage	—	
Counterweight	—	
Boom Type	Reach	
Stick Length	2.50 m (8'2")	2.92 m (9'7")
H115E S	✓	✓
H120 GC	✓	✓
H120 GC Side-mount		✓
H120 GC S	✓	✓
H120E S	✓	✓
H130E S	✓	✓

(continued on next page)

Hammer Technical Specifications

Matching – Tracked Excavators *(continued)*

Match
 Working Range Front Only
 Allowed Usage on Machine Less Than 50%
 No Match

320D2 GC *(continued)*

Cat Pin Grabber Coupler

Undercarriage	—	
Counterweight	—	
Boom Type	Reach	
Stick Length	2.50 m (8'2")	2.92 m (9'7")
H115E S	✓	✓
H120 GC	✓	✓*
H120 GC Side-mount		✓
H120 GC S	✓	✓*
H120E S	✓	✓
H130E S	✓	✓*

CW-40 S Dedicated Coupler

Undercarriage	—	
Counterweight	—	
Boom Type	Reach	
Stick Length	2.50 m (8'2")	2.92 m (9'7")
H115E S	✓	✓
H120 GC	✓	✓
H120 GC S	✓	✓
H120E S	✓	✓
H130E S	✓	✓

CW-40 Dedicated Coupler

Undercarriage	—	
Counterweight	—	
Boom Type	Reach	
Stick Length	2.50 m (8'2")	2.92 m (9'7")
H115E S	✓	✓
H120 GC	✓	✓
H120 GC S	✓	✓
H120E S	✓	✓
H130E S	✓	✓*

320D2

Pin-on

Undercarriage	—			L		
Counterweight	—			—		
Boom Type	Reach HD		ME	Reach HD		ME
Stick Length	2.50 m HD (8'2")	2.92 m HD (9'7")	2.40 m (7'10")	2.50 m HD (8'2")	2.92 m HD (9'7")	2.40 m (7'10")
H115E S	✓	✓		✓	✓	
H120 GC	✓	✓	✓	✓	✓	✓
H120 GC Side-mount	✓	✓		✓	✓	
H120 GC S	✓	✓	✓	✓	✓	✓
H120E S	✓	✓	✓	✓	✓	✓
H130E S	✓	✓	✓	✓	✓	✓

(continued on next page)

Matching – Tracked Excavators *(continued)*

Match
 Working Range Front Only
 Allowed Usage on Machine Less Than 50%
 No Match

320D2 *(continued)*

Cat Pin Grabber Coupler

Undercarriage	—		L	
Counterweight	—		—	
Boom Type	Reach HD		Reach HD	
Stick Length	2.50 m HD (8'2")	2.92 m HD (9'7")	2.50 m HD (8'2")	2.92 m HD (9'7")
H115E S	✓	✓	✓	✓
H120 GC	✓		✓	✓
H120 GC Side-mount	✓	✓	✓	✓
H120 GC S	✓	✓*	✓	✓
H120E S	✓	✓	✓	✓
H130E S	✓*		✓	✓

CW-40 S Dedicated Coupler

Undercarriage	L	
Counterweight	—	
Boom Type	Reach HD	
Stick Length	2.50 m HD (8'2")	2.92 m HD (9'7")
H115E S	✓	✓
H120 GC	✓	✓
H120 GC S	✓	✓
H120E S	✓	✓
H130E S	✓	✓

CW-40 Dedicated Coupler

Undercarriage	L	
Counterweight	—	
Boom Type	Reach HD	
Stick Length	2.50 m HD (8'2")	2.92 m HD (9'7")
H115E S	✓	✓
H120 GC	✓	✓
H120 GC S	✓	✓
H120E S	✓	✓
H130E S	✓	✓

320F

Pin-on

Undercarriage	—		L			
Counterweight	—		—			
Boom Type	Reach	VA	Reach	VA	Reach	VA
Stick Length	2.92 m HD (9'7")	2.92 m HD (9'7")	2.50 m HD (8'2")	2.92 m HD (9'7")	2.50 m HD (8'2")	2.92 m HD (9'7")
H115E S	✓	✓	✓	✓	✓	✓
H120 GC				✓		
H120 GC S	✓	✓	✓	✓	✓	✓
H120E S	✓	✓	✓	✓	✓	✓
H130E S	✓	✓	✓	✓	✓	✓

(continued on next page)

Hammer Technical Specifications

Matching – Tracked Excavators (continued)

Match
 * Working Range Front Only
 † Allowed Usage on Machine Less Than 50%
 No Match

320F (continued)

Cat Pin Grabber Coupler

Undercarriage	—		L			
Counterweight	—		—			
Boom Type	Reach		Reach		VA	
Stick Length	2.92 m HD (9'7")	2.92 m HD (9'7")	2.50 m HD (8'2")	2.92 m HD (9'7")	2.50 m HD (8'2")	2.92 m HD (9'7")
H115E S	✓	✓	✓	✓	✓	✓
H120 GC				✓		
H120 GC S	✓	✓*	✓	✓	✓	✓
H120E S	✓	✓	✓	✓	✓	✓
H130E S	✓*		✓	✓	✓	✓

CW-40 S Dedicated Coupler

Undercarriage	—		L			
Counterweight	—		—			
Boom Type	Reach	VA	Reach		VA	
Stick Length	2.92 m HD (9'7")	2.92 m HD (9'7")	2.50 m HD (8'2")	2.92 m HD (9'7")	2.50 m HD (8'2")	2.92 m HD (9'7")
H115E S	✓	✓	✓	✓	✓	✓
H120 GC S	✓	✓	✓	✓	✓	✓
H120E S	✓	✓	✓	✓	✓	✓
H130E S	✓	✓*	✓	✓	✓	✓

CW-40 Dedicated Coupler

Undercarriage	—		L			
Counterweight	—		—			
Boom Type	Reach	VA	Reach		VA	
Stick Length	2.92 m HD (9'7")	2.92 m HD (9'7")	2.50 m HD (8'2")	2.92 m HD (9'7")	2.50 m HD (8'2")	2.92 m HD (9'7")
H115E S	✓	✓	✓	✓	✓	✓
H120 GC S	✓	✓	✓	✓	✓	✓
H120E S	✓	✓	✓	✓	✓	✓
H130E S	✓	✓*	✓	✓	✓	✓

320 GC

Pin-on

Undercarriage	—		L			
Counterweight	3.7 mt		4.2 mt		4.2 mt	
Boom Type	Reach		Reach		Reach	
Stick Length	2.50 m (8'2")	2.92 m (9'7")	2.50 m (8'2")	2.92 m (9'7")	2.50 m (8'2")	2.92 m (9'7")
H115E S	✓	✓	✓	✓	✓	✓
H120 GC	✓	✓	✓	✓	✓	✓
H120 GC Side-mount	✓	✓				
H120 GC S	✓	✓	✓	✓	✓	✓
H120E S	✓	✓	✓	✓	✓	✓
H130E S	✓	✓†	✓	✓†	✓	✓†

(continued on next page)

Matching – Tracked Excavators (continued)

Match
 * Working Range Front Only
 † Allowed Usage on Machine Less Than 50%
 No Match

320 GC (continued)

Cat Pin Grabber Coupler

Undercarriage	—				L	
Counterweight	3.7 mt		4.2 mt		4.2 mt	
Boom Type	Reach		Reach		Reach	
Stick Length	2.50 m (8'2")	2.92 m (9'7")	2.50 m (8'2")	2.92 m (9'7")	2.50 m (8'2")	2.92 m (9'7")
H115E S	✓	✓	✓	✓	✓	✓
H120 GC	✓†	✓†*	✓†	✓†	✓†	✓†
H120 GC Side-mount	✓†	✓†				
H120 GC S	✓†	✓†	✓†	✓†	✓†	✓†
H120E S	✓†	✓†	✓†	✓†	✓†	✓†
H130E S	✓†	✓†*	✓†	✓†	✓†	✓†

CW-40 S Dedicated Coupler

Undercarriage	—				L	
Counterweight	3.7 mt		4.2 mt		4.2 mt	
Boom Type	Reach		Reach		Reach	
Stick Length	2.50 m (8'2")	2.92 m (9'7")	2.50 m (8'2")	2.92 m (9'7")	2.50 m (8'2")	2.92 m (9'7")
H115E S	✓	✓	✓	✓	✓	✓
H120 GC	✓†	✓†				
H120 GC S	✓†	✓†	✓†	✓†	✓†	✓†
H120E S	✓†	✓†	✓†	✓†	✓†	✓†
H130E S	✓†	✓†	✓†	✓†	✓†	✓†

CW-40 Dedicated Coupler

Undercarriage	—				L	
Counterweight			4.2 mt		4.2 mt	
Boom Type	Reach		Reach		Reach	
Stick Length	2.50 m (8'2")	2.92 m (9'7")	2.50 m (8'2")	2.92 m (9'7")	2.50 m (8'2")	2.92 m (9'7")
H115E S	✓	✓	✓	✓	✓	✓
H120 GC	✓†	✓†				
H120 GC S	✓†	✓†	✓†	✓†	✓†	✓†
H120E S	✓†	✓†	✓†	✓†	✓†	✓†
H130E S	✓†	✓†	✓†	✓†	✓†	✓†

320

Pin-on

Undercarriage	—			
Counterweight	3.7 mt			
Boom Type	Reach		Reach HD	
Stick Length	2.50 m (8'2")	2.92 m (9'7")	2.50 m HD (8'2")	2.92 m HD (9'7")
H115E S	✓	✓	✓	✓
H120 GC				
H120 GC S				
H120E S	✓	✓	✓	✓
H130E S	✓	✓†	✓	✓

(continued on next page)

Hammer Technical Specifications

Matching – Tracked Excavators (continued)

Match
 * Working Range Front Only
 † Allowed Usage on Machine Less Than 50%
 No Match

320 (continued)

Pin-on (continued)

Undercarriage	L							
Counterweight	3.7 mt				4.2 mt			
Boom Type	Reach HD		Reach		Reach HD		VA	
Stick Length	2.50 m HD (8'2")	2.92 m HD (9'7")	2.50 m (8'2")	2.92 m (9'7")	2.50 m HD (8'2")	2.92 m HD (9'7")	2.50 m (8'2")	2.92 m (9'7")
H115E S	✓	✓	✓	✓	✓	✓	✓	✓
H120 GC	✓	✓	✓	✓	✓	✓		
H120 GC S	✓	✓	✓	✓	✓	✓	✓	✓
H120E S	✓	✓	✓	✓	✓	✓	✓	✓
H130E S	✓	✓	✓	✓†	✓	✓	✓	✓†

Cat Pin Grabber Coupler

Undercarriage	—			
Counterweight	3.7 mt			
Boom Type	Reach		Reach HD	
Stick Length	2.50 m (8'2")	2.92 m (9'7")	2.50 m HD (8'2")	2.92 m HD (9'7")
H115E S	✓	✓	✓	✓
H120 GC				
H120 GC Side-mount				
H120 GC S				
H120E S	✓†	✓†	✓	✓
H130E S	✓†	✓†*	✓*	

Cat Pin Grabber Coupler (continued)

Undercarriage	L							
Counterweight	3.7 mt				4.2 mt			
Boom Type	Reach HD		Reach		Reach HD		VA	
Stick Length	2.50 m HD (8'2")	2.92 m HD (9'7")	2.50 m (8'2")	2.92 m (9'7")	2.50 m HD (8'2")	2.92 m HD (9'7")	2.50 m (8'2")	2.92 m (9'7")
H115E S	✓	✓	✓	✓	✓	✓	✓	✓
H120 GC	✓	✓	✓†	✓†	✓	✓		
H120 GC Side-mount					✓	✓		
H120 GC S	✓	✓	✓†	✓†	✓	✓	✓†	✓†
H120E S	✓	✓	✓†	✓†	✓	✓	✓†	✓†
H130E S	✓	✓	✓†	✓†	✓	✓	✓†	✓†

CW-40 S Dedicated Coupler

Undercarriage	L							
Counterweight	3.7 mt				4.2 mt			
Boom Type	Reach HD		Reach		Reach HD		VA	
Stick Length	2.50 m HD (8'2")	2.92 m HD (9'7")	2.50 m (8'2")	2.92 m (9'7")	2.50 m HD (8'2")	2.92 m HD (9'7")	2.50 m (8'2")	2.92 m (9'7")
H115E S	✓	✓	✓	✓	✓	✓	✓	✓
H120 GC	✓	✓			✓	✓		
H120 GC S	✓	✓	✓†	✓†	✓	✓	✓†	✓†
H120E S	✓	✓	✓†	✓†	✓	✓	✓†	✓†
H130E S	✓	✓	✓†	✓†	✓	✓	✓†	✓†

(continued on next page)

Matching – Tracked Excavators *(continued)*

Match
 Working Range Front Only
 Allowed Usage on Machine Less Than 50%
 No Match

320 *(continued)*

CW-40 Dedicated Coupler

Undercarriage	L							
Counterweight	3.7 mt				4.2 mt			
Boom Type	Reach HD		Reach		Reach HD		VA	
Stick Length	2.50 m HD (8'2")	2.92 m HD (9'7")	2.50 m (8'2")	2.92 m (9'7")	2.50 m HD (8'2")	2.92 m HD (9'7")	2.50 m (8'2")	2.92 m (9'7")
H115E S	✓	✓	✓	✓	✓	✓	✓	✓
H120 GC	✓	✓			✓	✓		
H120 GC S	✓	✓	✓†	✓†	✓	✓	✓†	✓†
H120E S	✓	✓	✓†	✓†	✓	✓	✓†	✓†
H130E S	✓	✓	✓†	✓†	✓	✓	✓†	✓†

323D2

Pin-on

Undercarriage	L			
Counterweight	—			
Boom Type	Reach	Reach HD		ME
Stick Length	2.92 m (9'7")	2.50 m HD (8'2")	2.92 m HD (9'7")	2.40 m (7'10")
H120 GC	✓	✓	✓	✓
H120 GC Side-mount		✓	✓	✓
H120 GC S	✓	✓	✓	✓
H120E S	✓	✓	✓	✓
H130E S	✓	✓	✓	✓

Cat Pin Grabber Coupler

Undercarriage	L		
Counterweight	—		
Boom Type	Reach HD		ME
Stick Length	2.50 m HD (8'2")	2.92 m HD (9'7")	2.40 m (7'10")
H120 GC	✓	✓	✓
H120 GC Side-mount	✓	✓	✓
H120 GC S	✓	✓	✓
H120E S	✓	✓	✓
H130E S	✓	✓	✓

CW-40 S Dedicated Coupler

Undercarriage	L	
Counterweight	—	
Boom Type	Reach HD	
Stick Length	2.50 m HD (8'2")	2.92 m HD (9'7")
H120 GC	✓	✓
H120 GC S	✓	✓
H120E S	✓	✓
H130E S	✓	✓

(continued on next page)

Hammer Technical Specifications

Matching – Tracked Excavators *(continued)*

Match
 Working Range Front Only
 Allowed Usage on Machine Less Than 50%
 No Match

323D2 *(continued)*

CW-40 Dedicated Coupler

Undercarriage	L		
Counterweight	—		
Boom Type	Reach HD		ME
Stick Length	2.50 m HD (8'2")	2.92 m HD (9'7")	2.40 m (7'10")
H120 GC	✓	✓	✓
H120 GC S	✓	✓	✓
H120E S	✓	✓	✓
H130E S	✓	✓	✓

323F

Pin-on

Undercarriage	L						
Counterweight	—						
Boom Type	Reach			Reach HD		VA	
Stick Length	2.50 m HD (8'2")	2.92 m HD (9'7")	2.92 m HD (9'7")	2.92 m HD-TR (9'7")	3.86 m HD (12'8")	2.50 m HD (8'2")	2.92 m HD (9'7")
H120 GC		✓	✓	✓	✓		
H120 GC S	✓	✓	✓	✓	✓	✓	✓
H120E S	✓	✓	✓	✓	✓	✓	✓
H130E S	✓	✓	✓	✓	✓	✓	✓

Pin-on *(continued)*

Undercarriage	L							
Counterweight	5.35 mt				—			
Boom Type	Reach		VA		Reach		VA	
Stick Length	2.50 m HD (8'2")	2.92 m HD (9'7")	2.50 m HD (8'2")	2.92 m HD (9'7")	2.50 m HD (8'2")	2.92 m HD (9'7")	2.50 m HD (8'2")	2.92 m HD (9'7")
H120 GC								
H120 GC S	✓	✓	✓	✓	✓	✓	✓	✓
H120E S	✓	✓	✓	✓	✓	✓	✓	✓
H130E S	✓	✓	✓	✓	✓	✓	✓	✓

Cat Pin Grabber Coupler

Undercarriage	L						
Counterweight	—						
Boom Type	Reach		Reach HD			VA	
Stick Length	2.50 m HD (8'2")	2.92 m HD (9'7")	2.92 m HD (9'7")	2.92 m HD-TR (9'7")	3.86 m HD (12'8")	2.50 m HD (8'2")	2.92 m HD (9'7")
H120 GC		✓	✓	✓	✓		
H120 GC S	✓	✓	✓	✓	✓	✓	✓
H120E S	✓	✓	✓	✓	✓	✓	✓
H130E S	✓	✓	✓	✓	✓	✓	✓

(continued on next page)

Matching – Tracked Excavators (continued)

Match
 Working Range Front Only
 Allowed Usage on Machine Less Than 50%
 No Match

323F (continued)

Cat Pin Grabber Coupler (continued)

Undercarriage	L				LN			
Counterweight	5.35 mt				—			
Boom Type	Reach		VA		Reach		VA	
Stick Length	2.50 m HD (8'2")	2.92 m HD (9'7")	2.50 m HD (8'2")	2.92 m HD (9'7")	2.50 m HD (8'2")	2.92 m HD (9'7")	2.50 m HD (8'2")	2.92 m HD (9'7")
H120 GC								
H120 GC S	✓	✓	✓	✓	✓	✓	✓	✓*
H120E S	✓	✓	✓	✓	✓	✓	✓	✓
H130E S	✓	✓	✓	✓	✓	✓	✓*	

CW-40 S Dedicated Coupler

Undercarriage	L							
Counterweight	—				5.35 mt			
Boom Type	Reach		VA		Reach		VA	
Stick Length	2.50 m HD (8'2")	2.92 m HD (9'7")	2.50 m HD (8'2")	2.92 m HD (9'7")	2.50 m HD (8'2")	2.92 m HD (9'7")	2.50 m HD (8'2")	2.92 m HD (9'7")
H120 GC S	✓	✓	✓	✓	✓	✓	✓	✓
H120E S	✓	✓	✓	✓	✓	✓	✓	✓
H130E S	✓	✓	✓	✓	✓	✓	✓	✓

CW-40 S Dedicated Coupler (continued)

Undercarriage	LN			
Counterweight	—			
Boom Type	Reach		VA	
Stick Length	2.50 m HD (8'2")	2.92 m HD (9'7")	2.50 m HD (8'2")	2.92 m HD (9'7")
H120 GC S	✓	✓	✓	✓
H120E S	✓	✓	✓	✓
H130E S	✓	✓	✓	✓*

CW-40 Dedicated Coupler

Undercarriage	L							
Counterweight	—				5.35 mt			
Boom Type	Reach		VA		Reach		VA	
Stick Length	2.50 m HD (8'2")	2.92 m HD (9'7")	2.50 m HD (8'2")	2.92 m HD (9'7")	2.50 m HD (8'2")	2.92 m HD (9'7")	2.50 m HD (8'2")	2.92 m HD (9'7")
H120 GC S	✓	✓	✓	✓	✓	✓	✓	✓
H120E S	✓	✓	✓	✓	✓	✓	✓	✓
H130E S	✓	✓	✓	✓	✓	✓	✓	✓

CW-40 Dedicated Coupler (continued)

Undercarriage	LN			
Counterweight	—			
Boom Type	Reach		VA	
Stick Length	2.50 m HD (8'2")	2.92 m HD (9'7")	2.50 m HD (8'2")	2.92 m HD (9'7")
H120 GC S	✓	✓	✓	✓
H120E S	✓	✓	✓	✓
H130E S	✓	✓	✓	✓*

(continued on next page)

Hammer Technical Specifications

Matching – Tracked Excavators (continued)

Match
 Working Range Front Only
 † Allowed Usage on Machine Less Than 50%
 No Match

323

Pin-on

Undercarriage	L						
Counterweight	4.2 mt						
Boom Type	Reach			Reach HD			
Stick Length	2.50 m (8'2")	2.92 m (9'7")	3.86 m (12'8")	2.50 m (8'2")	2.50 m HD (8'2")	2.92 m (9'7")	2.92 m HD (9'7")
H120 GC	✓	✓	✓	✓	✓	✓	✓
H120 GC Side-mount	✓	✓			✓		✓
H120 GC S	✓	✓	✓	✓	✓	✓	✓
H120E S	✓	✓	✓	✓	✓	✓	✓
H130E S	✓	✓†	✓	✓	✓	✓	✓

Pin-on (continued)

Undercarriage	L				
Counterweight	4.2 mt		5.4 mt		
Boom Type	VA		Reach		
Stick Length	2.50 m (8'2")	2.92 m (9'7")	2.50 m (8'2")	2.92 m (9'7")	3.86 m (12'8")
H120 GC			✓	✓	✓
H120 GC Side-mount			✓	✓	
H120 GC S	✓	✓	✓	✓	✓
H120E S	✓	✓	✓	✓	✓
H130E S	✓	✓†	✓	✓†	✓

Pin-on (continued)

Undercarriage	L						
Counterweight	5.4 mt						
Boom Type	Reach HD					VA	
Stick Length	2.50 m (8'2")	2.50 m HD (8'2")	2.92 m (9'7")	2.92 m HD (9'7")	2.92 m TR (9'7")	2.50 m (8'2")	2.92 m (9'7")
H120 GC	✓	✓	✓	✓	✓		
H120 GC Side-mount		✓		✓			
H120 GC S	✓	✓	✓	✓	✓	✓	✓
H120E S	✓	✓	✓	✓	✓	✓	✓
H130E S	✓	✓	✓	✓	✓	✓	✓†

Cat Pin Grabber Coupler

Undercarriage	L						
Counterweight	4.2 mt						
Boom Type	Reach			Reach HD			
Stick Length	2.50 m (8'2")	2.92 m (9'7")	3.86 m (12'8")	2.50 m (8'2")	2.50 m HD (8'2")	2.92 m (9'7")	2.92 m HD (9'7")
H120 GC	✓†	✓†	✓†	✓	✓	✓	✓
H120 GC Side-mount	✓†	✓†			✓		✓
H120 GC S	✓†	✓†	✓†	✓	✓	✓	✓
H120E S	✓†	✓†	✓†	✓	✓	✓	✓
H130E S	✓†	✓†		✓	✓	✓	✓

(continued on next page)

Matching – Tracked Excavators (continued)

Match
 Working Range Front Only
 † Allowed Usage on Machine Less Than 50%
 No Match

323 (continued)

Cat Pin Grabber Coupler (continued)

Undercarriage	L				
Counterweight	4.2 mt		5.4 mt		
Boom Type	VA		Reach		
Stick Length	2.50 m (8'2")	2.92 m (9'7")	2.50 m (8'2")	2.92 m (9'7")	3.86 m (12'8")
H120 GC			√†	√†	√†
H120 GC Side-mount			√†	√†	
H120 GC S	√†	√†	√†	√†	√†
H120E S	√†	√†	√†	√†	√†
H130E S	√†	√†	√†	√†	

Cat Pin Grabber Coupler (continued)

Undercarriage	L						
Counterweight	5.4 mt						
Boom Type	Reach HD					VA	
Stick Length	2.50 m (8'2")	2.50 m HD (8'2")	2.92 m (9'7")	2.92 m HD (9'7")	2.92 m TR (9'7")	2.50 m (8'2")	2.92 m (9'7")
H120 GC	✓	✓	✓	✓	✓		
H120 GC Side-mount		✓		✓			
H120 GC S	✓	✓	✓	✓	✓	√†	√†
H120E S	✓	✓	✓	✓	✓	√†	√†
H130E S	✓	✓	✓	✓	✓	√†	√†

CW-40 S Dedicated Coupler

Undercarriage	L					
Counterweight	4.2 mt					
Boom Type	Reach		Reach HD		VA	
Stick Length	2.50 m (8'2")	2.92 m (9'7")	2.50 m HD (8'2")	2.92 m HD (9'7")	2.50 m (8'2")	2.92 m (9'7")
H120 GC			✓	✓		
H120 GC S	√†	√†	✓	✓	√†	√†
H120E S	√†	√†	✓	✓	√†	√†
H130E S	√†	√†	✓	✓	√†	√†

CW-40 S Dedicated Coupler (continued)

Undercarriage	L					
Counterweight	5.4 mt					
Boom Type	Reach		Reach HD		VA	
Stick Length	2.50 m (8'2")	2.92 m (9'7")	2.50 m HD (8'2")	2.92 m HD (9'7")	2.50 m (8'2")	2.92 m (9'7")
H120 GC			✓	✓		
H120 GC S	√†	√†	✓	✓	√†	√†
H120E S	√†	√†	✓	✓	√†	√†
H130E S	√†	√†	✓	✓	√†	√†

(continued on next page)

Hammer Technical Specifications

Matching – Tracked Excavators (continued)

Match
 * Working Range Front Only
 † Allowed Usage on Machine Less Than 50%
 No Match

323 (continued)

CW-40 Dedicated Coupler

Undercarriage	L					
Counterweight	4.2 mt					
Boom Type	Reach		Reach HD		VA	
Stick Length	2.50 m (8'2")	2.92 m (9'7")	2.50 m HD (8'2")	2.92 m HD (9'7")	2.50 m (8'2")	2.92 m (9'7")
H120 GC			✓	✓		
H120 GC S	✓†	✓†	✓	✓	✓†	✓†
H120E S	✓†	✓†	✓	✓	✓†	✓†
H130E S	✓†	✓†	✓	✓	✓†	✓†

CW-40 Dedicated Coupler (continued)

Undercarriage	L					
Counterweight	5.4 mt					
Boom Type	Reach		Reach HD		VA	
Stick Length	2.50 m (8'2")	2.92 m (9'7")	2.50 m HD (8'2")	2.92 m HD (9'7")	2.50 m (8'2")	2.92 m (9'7")
H120 GC			✓	✓		
H120 GC S	✓†	✓†	✓	✓	✓†	✓†
H120E S	✓†	✓†	✓	✓	✓†	✓†
H130E S	✓†	✓†	✓	✓	✓†	✓†

325F CR

Pin-on

Undercarriage	L	
Counterweight	—	
Boom Type	Reach	VA
Stick Length	2.92 m HD (9'7")	2.92 m HD (9'7")
H120 GC	✓	
H120 GC S	✓	✓
H120E S	✓	✓
H130E S	✓	✓

Cat Pin Grabber Coupler

Undercarriage	L	
Counterweight	—	
Boom Type	Reach	VA
Stick Length	2.92 m HD (9'7")	2.92 m HD (9'7")
H120 GC	✓	
H120 GC S	✓	✓
H120E S	✓	✓
H130E S	✓	✓

(continued on next page)

Matching – Tracked Excavators *(continued)*

Match
 Working Range Front Only
 Allowed Usage on Machine Less Than 50%
 No Match

325F CR *(continued)*

CW-40 S Dedicated Coupler

Undercarriage	L	
Counterweight	—	
Boom Type	Reach	VA
Stick Length	2.92 m HD (9'7")	2.92 m HD (9'7")
H120 GC S	✓	✓
H120E S	✓	✓
H130E S	✓	✓

CW-40 Dedicated Coupler

Undercarriage	L	
Counterweight	—	
Boom Type	Reach	VA
Stick Length	2.92 m HD (9'7")	2.92 m HD (9'7")
H120 GC S	✓	✓
H120E S	✓	✓
H130E S	✓	✓

326D2

Pin-on

Undercarriage	L		
Counterweight	—		
Boom Type	Reach		Reach HD
Stick Length	2.50 m (8'2")	2.95 m (9'8")	2.95 m HD (9'8")
H120 GC	✓	✓	✓
H120 GC Side-mount			✓
H120 GC S	✓	✓	✓
H120E S	✓	✓	✓
H130 GC	✓	✓	✓
H130 GC Side-mount			✓
H130 GC S	✓	✓	✓
H130E S	✓	✓	✓
H140E S	✓	✓	✓

(continued on next page)

Hammer Technical Specifications

Matching – Tracked Excavators *(continued)*

Match
 Working Range Front Only
 Allowed Usage on Machine Less Than 50%
 No Match

326D2 *(continued)*

Cat Pin Grabber Coupler

Undercarriage	L		
Counterweight	—		
Boom Type	Reach		Reach HD
Stick Length	2.50 m (8'2")	2.95 m (9'8")	2.95 m HD (9'8")
H120 GC	✓	✓	✓
H120 GC Side-mount			✓
H120 GC S	✓	✓	✓
H120E S	✓	✓	✓
H130 GC	✓	✓	✓
H130 GC Side-mount			✓
H130 GC S	✓	✓	✓
H130E S	✓	✓	✓
H140E S	✓	✓	✓

CW-40 Dedicated Coupler

Undercarriage	L	
Counterweight	—	
Boom Type	Reach	Reach HD
Stick Length	2.50 m (8'2")	2.95 m HD (9'8")
H120 GC	✓	✓
H120 GC S	✓	✓
H120E S	✓	✓
H130 GC	✓	✓
H130 GC S	✓	✓
H130E S	✓	✓
H140E S	✓	✓

326F

Pin-on

Undercarriage	L				
Counterweight	—				
Boom Type	Reach HD			VA	
Stick Length	2.50 m HD (8'2")	2.95 m HD (9'8")	3.60 m HD (11'10")	2.50 m HD (8'2")	2.95 m HD (9'8")
H120 GC	✓	✓	✓		
H120 GC S	✓	✓	✓	✓	✓
H120E S	✓	✓	✓	✓	✓
H130 GC	✓	✓	✓		
H130 GC S	✓	✓	✓	✓	✓
H130E S	✓	✓	✓	✓	✓
H140E S	✓	✓	✓	✓	✓

(continued on next page)

Matching – Tracked Excavators *(continued)*

Match
 Working Range Front Only
 Allowed Usage on Machine Less Than 50%
 No Match

326F *(continued)*

Pin-on *(continued)*

Undercarriage	LN			
Counterweight	—			
Boom Type	Reach HD		VA	
Stick Length	2.50 m HD (8'2")	2.95 m HD (9'8")	2.50 m HD (8'2")	2.95 m HD (9'8")
H120 GC				
H120 GC S	✓	✓	✓	✓
H120E S	✓	✓	✓	✓
H130 GC				
H130 GC S	✓	✓	✓	✓
H130E S	✓	✓	✓	✓
H140E S	✓	✓	✓	✓

Cat Pin Grabber Coupler

Undercarriage	L				
Counterweight	—				
Boom Type	Reach HD			VA	
Stick Length	2.50 m HD (8'2")	2.95 m HD (9'8")	3.60 m HD (11'10")	2.50 m HD (8'2")	2.95 m HD (9'8")
H120 GC	✓	✓	✓		
H120 GC S	✓	✓	✓	✓	✓
H120E S	✓	✓	✓	✓	✓
H130 GC	✓	✓	✓*		
H130 GC S	✓	✓	✓	✓	✓
H130E S	✓	✓	✓	✓	✓
H140E S	✓	✓	✓*	✓	✓

Cat Pin Grabber Coupler *(continued)*

Undercarriage	LN			
Counterweight	—			
Boom Type	Reach HD		VA	
Stick Length	2.50 m HD (8'2")	2.95 m HD (9'8")	2.50 m HD (8'2")	2.95 m HD (9'8")
H120 GC				
H120 GC S	✓	✓	✓	✓
H120E S	✓	✓	✓	✓
H130 GC				
H130 GC S	✓	✓	✓	✓*
H130E S	✓	✓	✓	✓
H140E S	✓	✓	✓*	

(continued on next page)

Hammer Technical Specifications

Matching – Tracked Excavators (continued)

Match
 * Working Range Front Only
 † Allowed Usage on Machine Less Than 50%
 No Match

326F (continued)

CW-40 Dedicated Coupler

Undercarriage	L				LN			
Counterweight	—				—			
Boom Type	Reach HD		VA		Reach HD		VA	
Stick Length	2.50 m HD (8'2")	2.95 m HD (9'8")	2.50 m HD (8'2")	2.95 m HD (9'8")	2.50 m HD (8'2")	2.95 m HD (9'8")	2.50 m HD (8'2")	2.95 m HD (9'8")
H120 GC S	✓	✓	✓	✓	✓	✓	✓	✓
H120E S	✓	✓	✓	✓	✓	✓	✓	✓
H130 GC S	✓	✓	✓	✓	✓	✓	✓	✓
H130E S	✓	✓	✓	✓	✓	✓	✓	✓
H140E S	✓	✓	✓	✓	✓	✓	✓	✓*

329D2

Pin-on

Undercarriage	—			L		
Counterweight	—			—		
Boom Type	Reach		ME	Reach		ME
Stick Length	2.65 m (8'8")	3.20 m (10'6")	2.50 m (8'2")	2.65 m (8'8")	3.20 m (10'6")	2.50 m (8'2")
H120E S	✓	✓	✓	✓	✓	✓
H130E S	✓	✓	✓	✓	✓	✓
H140E S	✓	✓	✓	✓	✓	✓

CW-45 S Dedicated Coupler

Undercarriage	—			L		
Counterweight	—			—		
Boom Type	Reach		ME	Reach		ME
Stick Length	2.65 m (8'8")	3.20 m (10'6")	2.50 m (8'2")	2.65 m (8'8")	3.20 m (10'6")	2.50 m (8'2")
H120E S	✓	✓	✓	✓	✓	✓
H130E S	✓	✓	✓	✓	✓	✓
H140E S	✓	✓	✓	✓	✓	✓

CW-45 Dedicated Coupler

Undercarriage	—			L		
Counterweight	—			—		
Boom Type	Reach		ME	Reach		ME
Stick Length	2.65 m (8'8")	3.20 m (10'6")	2.50 m (8'2")	2.65 m (8'8")	3.20 m (10'6")	2.50 m (8'2")
H120E S	✓	✓	✓	✓	✓	✓
H130E S	✓	✓	✓	✓	✓	✓
H140E S	✓	✓*	✓	✓	✓	✓

(continued on next page)

Matching – Tracked Excavators *(continued)*

Match
 * Working Range Front Only
 † Allowed Usage on Machine Less Than 50%
 No Match

330D2

Pin-on

Undercarriage	L			
Counterweight	—			
Boom Type	Reach	Reach HD		ME
Stick Length	2.65 m (8'8")	2.65 m HD (8'8")	3.20 m HD (10'6")	2.50 m (8'2")
H120E S	✓	✓	✓	
H130 GC	✓	✓	✓	✓
H130 GC Side-mount		✓	✓	✓
H130 GC S	✓	✓	✓	✓
H130E S	✓	✓	✓	✓
H140 GC	✓	✓	✓	✓
H140 GC S	✓	✓	✓	✓
H140E S	✓	✓	✓	✓

Cat Pin Grabber Coupler

Undercarriage	L			
Counterweight	—			
Boom Type	Reach	Reach HD		ME
Stick Length	2.65 m (8'8")	2.65 m HD (8'8")	3.20 m HD (10'6")	2.50 m (8'2")
H120E S	✓	✓	✓	
H130 GC	✓	✓	✓	✓
H130 GC Side-mount		✓	✓	✓
H130 GC S	✓	✓	✓	✓
H130E S	✓	✓	✓	✓
H140 GC	✓	✓		✓
H140 GC S	✓	✓*		✓
H140E S	✓	✓	✓	✓

CW-45 S Dedicated Coupler

Undercarriage	L			
Counterweight	—			
Boom Type	Reach	Reach HD		ME
Stick Length	2.65 m (8'8")	2.65 m HD (8'8")	3.20 m HD (10'6")	2.50 m (8'2")
H120E S	✓	✓	✓	
H130 GC	✓	✓	✓	✓
H130 GC S	✓	✓	✓	✓
H130E S	✓	✓	✓	✓
H140 GC	✓	✓		✓
H140 GC S	✓*	✓*		✓
H140E S	✓	✓	✓	✓

(continued on next page)

Hammer Technical Specifications

Matching – Tracked Excavators *(continued)*

Match
 Working Range Front Only
 Allowed Usage on Machine Less Than 50%
 No Match

330D2 *(continued)*

CW-45 Dedicated Coupler

Undercarriage	L			
Counterweight	—			
Boom Type	Reach	Reach HD		ME
Stick Length	2.65 m (8'8")	2.65 m HD (8'8")	3.20 m HD (10'6")	2.50 m (8'2")
H120E S	✓	✓	✓	
H130 GC	✓	✓	✓	✓
H130 GC S	✓	✓	✓	✓
H130E S	✓	✓	✓	✓
H140 GC	✓	✓		✓
H140 GC S	✓	✓*		✓
H140E S	✓	✓	✓	✓

330F

Pin-on

Undercarriage	L				LN	
Counterweight	—				—	
Boom Type	Reach ES	Reach HD			Reach HD	
Stick Length	3.20 m ES (10'6")	2.65 m HD (8'8")	3.20 m HD (10'6")	3.75 m HD (12'4")	2.65 m HD (8'8")	3.20 m HD (10'6")
H120E S	✓	✓	✓	✓	✓	✓
H130 GC	✓		✓	✓		
H130 GC S	✓	✓	✓	✓	✓	✓
H130E S	✓	✓	✓	✓	✓	✓
H140 GC	✓		✓	✓		
H140 GC S	✓	✓	✓	✓	✓	✓
H140E S	✓	✓	✓	✓	✓	✓

Cat Pin Grabber Coupler

Undercarriage	L			LN	
Counterweight	—			—	
Boom Type	Reach HD			Reach HD	
Stick Length	2.65 m HD (8'8")	3.20 m HD (10'6")	3.75 m HD (12'4")	2.65 m HD (8'8")	3.20 m HD (10'6")
H120E S	✓	✓	✓	✓	✓
H130 GC		✓	✓		
H130 GC S	✓	✓	✓	✓	✓
H130E S	✓	✓	✓	✓	✓
H140 GC		✓	✓*		
H140 GC S	✓	✓*		✓*	
H140E S	✓	✓	✓	✓	✓

(continued on next page)

Matching – Tracked Excavators *(continued)*

Match
 * Working Range Front Only
 † Allowed Usage on Machine Less Than 50%
 No Match

330F *(continued)*

CW-45 S Dedicated Coupler

Undercarriage	L		LN	
Counterweight	—		—	
Boom Type	Reach HD		Reach HD	
Stick Length	2.65 m HD (8'8")	3.20 m HD (10'6")	2.65 m HD (8'8")	3.20 m HD (10'6")
H120E S	✓	✓	✓	✓
H130 GC S	✓	✓	✓	✓
H130E S	✓	✓	✓	✓
H140 GC S	✓	✓*	✓*	
H140E S	✓	✓	✓	✓

CW-45 Dedicated Coupler

Undercarriage	L		LN	
Counterweight	—		—	
Boom Type	Reach HD		Reach HD	
Stick Length	2.65 m HD (8'8")	3.20 m HD (10'6")	2.65 m HD (8'8")	3.20 m HD (10'6")
H120E S	✓	✓	✓	✓
H130 GC S	✓	✓	✓	✓
H130E S	✓	✓	✓	✓
H140 GC S	✓	✓*	✓*	
H140E S	✓	✓	✓	✓

330 GC

Pin-on

Undercarriage	—					
Counterweight	5.8 mt			6.7 mt		
Boom Type	Reach		ME	Reach		ME
Stick Length	2.65 m (8'8")	3.20 m (10'6")	2.50 m (8'2")	2.65 m (8'8")	3.20 m (10'6")	2.50 m (8'2")
H120E S	✓	✓	✓	✓	✓	✓
H130 GC	✓	✓	✓	✓	✓	✓
H130 GC Side-mount	✓	✓	✓	✓	✓	✓
H130 GC S	✓	✓	✓	✓	✓	✓
H130E S	✓	✓	✓	✓	✓	✓
H140 GC	✓	✓	✓	✓	✓	✓
H140 GC S	✓	✓*	✓	✓	✓	✓
H140E S	✓	✓	✓	✓	✓	✓

(continued on next page)

Hammer Technical Specifications

Matching – Tracked Excavators *(continued)*

Match
 Working Range Front Only
 Allowed Usage on Machine Less Than 50%
 No Match

330 GC *(continued)*

Pin-on *(continued)*

Undercarriage	L		
Counterweight	6.7 mt		
Boom Type	Reach		ME
Stick Length	2.65 m (8'8")	3.20 m (10'6")	2.50 m (8'2")
H120E S	✓	✓	
H130 GC	✓	✓	✓
H130 GC Side-mount			
H130 GC S	✓	✓	✓
H130E S	✓	✓	
H140 GC	✓	✓	✓
H140 GC S	✓	✓	✓
H140E S	✓	✓	

Cat Pin Grabber Coupler

Undercarriage	—						L	
Counterweight	5.8 mt			6.7 mt			6.7 mt	
Boom Type	Reach		ME	Reach		ME	Reach	
Stick Length	2.65 m (8'8")	3.20 m (10'6")	2.50 m (8'2")	2.65 m (8'8")	3.20 m (10'6")	2.50 m (8'2")	2.65 m (8'8")	3.20 m (10'6")
H120E S	✓	✓	✓	✓	✓	✓	✓	✓
H130 GC	✓	✓	✓	✓	✓	✓	✓	✓
H130 GC Side-mount	✓	✓	✓	✓	✓	✓		
H130 GC S	✓	✓	✓	✓	✓	✓	✓	✓
H130E S	✓	✓	✓	✓	✓	✓	✓	✓
H140 GC	✓*		✓	✓	✓*	✓	✓	✓
H140 GC S			✓*	✓		✓	✓	✓
H140E S	✓	✓	✓	✓	✓	✓	✓	✓

CW-45 S Dedicated Coupler

Undercarriage	—						L	
Counterweight	5.8 mt			6.7 mt			6.7 mt	
Boom Type	Reach		ME	Reach		ME	Reach	
Stick Length	2.65 m (8'8")	3.20 m (10'6")	2.50 m (8'2")	2.65 m (8'8")	3.20 m (10'6")	2.50 m (8'2")	2.65 m (8'8")	3.20 m (10'6")
H120E S	✓	✓	✓	✓	✓	✓	✓	✓
H130 GC	✓	✓	✓	✓	✓	✓		
H130 GC S	✓	✓	✓	✓	✓	✓	✓	✓
H130E S	✓	✓	✓	✓	✓	✓	✓	✓
H140 GC			✓	✓	✓*	✓		
H140 GC S			✓*	✓*		✓	✓	✓
H140E S	✓	✓	✓	✓	✓	✓	✓	✓

(continued on next page)

Matching – Tracked Excavators (continued)

Match
 Working Range Front Only
 Allowed Usage on Machine Less Than 50%
 No Match

330 GC (continued)

CW-45 Dedicated Coupler

Undercarriage	—						L	
Counterweight	5.8 mt			6.7 mt			6.7 mt	
Boom Type	Reach		ME	Reach		ME	Reach	
Stick Length	2.65 m (8'8")	3.20 m (10'6")	2.50 m (8'2")	2.65 m (8'8")	3.20 m (10'6")	2.50 m (8'2")	2.65 m (8'8")	3.20 m (10'6")
H120E S	✓	✓	✓	✓	✓	✓	✓	✓
H130 GC	✓	✓	✓	✓	✓	✓		
H130 GC S	✓	✓	✓	✓	✓	✓	✓	✓
H130E S	✓	✓	✓	✓	✓	✓	✓	✓
H140 GC	✓*		✓	✓	✓*	✓		
H140 GC S			✓*	✓*		✓	✓	✓
H140E S	✓	✓	✓	✓	✓	✓	✓	✓

330

Pin-on

Undercarriage	L						LN	
Counterweight	6.7 mt						6.7 mt	
Boom Type	Reach			Reach HD		ME	Reach	
Stick Length	2.65 m (8'8")	3.75 m (12'4")	3.20 m (10'6")	2.65 m HD (8'8")	3.20 m HD (10'6")	2.50 m (8'2")	2.65 m (8'8")	3.20 m (10'6")
H120E S	✓	✓	✓	✓	✓	✓	✓	✓
H130 GC	✓	✓	✓	✓	✓	✓		
H130 GC Side-mount				✓	✓	✓		
H130 GC S	✓	✓	✓	✓	✓	✓	✓	✓
H130E S	✓	✓	✓	✓	✓	✓	✓	✓
H140 GC	✓	✓	✓	✓	✓	✓		
H140 GC S	✓	✓	✓	✓	✓	✓	✓	✓
H140E S	✓	✓	✓	✓	✓	✓	✓	✓

Cat Pin Grabber Coupler

Undercarriage	L						LN	
Counterweight	6.7 mt						6.7 mt	
Boom Type	Reach			Reach HD		ME	Reach	
Stick Length	2.65 m (8'8")	3.75 m (12'4")	3.20 m (10'6")	2.65 m HD (8'8")	3.20 m HD (10'6")	2.50 m (8'2")	2.65 m (8'8")	3.20 m (10'6")
H120E S	✓	✓	✓	✓	✓	✓	✓	✓
H130 GC	✓	✓	✓	✓	✓	✓		
H130 GC Side-mount				✓	✓	✓		
H130 GC S	✓	✓	✓	✓	✓	✓	✓	✓
H130E S	✓	✓	✓	✓	✓	✓	✓	✓
H140 GC	✓	✓	✓	✓	✓	✓		
H140 GC S	✓		✓	✓	✓*	✓	✓	✓*
H140E S	✓	✓	✓	✓	✓	✓	✓	✓

(continued on next page)

Hammer Technical Specifications

Matching – Tracked Excavators *(continued)*

Match
 * Working Range Front Only
 † Allowed Usage on Machine Less Than 50%
 No Match

330 *(continued)*

CW-45 S Dedicated Coupler

Undercarriage	L					LN	
Counterweight	6.7 mt					6.7 mt	
Boom Type	Reach		Reach HD		ME	Reach	
Stick Length	2.65 m (8'8")	3.20 m (10'6")	2.65 m HD (8'8")	3.20 m HD (10'6")	2.50 m (8'2")	2.65 m (8'8")	3.20 m (10'6")
H120E S	✓	✓	✓	✓	✓	✓	✓
H130 GC			✓	✓	✓		
H130 GC S	✓	✓	✓	✓	✓	✓	✓
H130E S	✓	✓	✓	✓	✓	✓	✓
H140 GC			✓	✓	✓		
H140 GC S	✓	✓	✓	✓*	✓	✓	
H140E S	✓	✓	✓	✓	✓	✓	✓

CW-45 Dedicated Coupler

Undercarriage	L					LN	
Counterweight	6.7 mt					6.7 mt	
Boom Type	Reach		Reach HD		ME	Reach	
Stick Length	2.65 m (8'8")	3.20 m (10'6")	2.65 m HD (8'8")	3.20 m HD (10'6")	2.50 m (8'2")	2.65 m (8'8")	3.20 m (10'6")
H120E S	✓	✓	✓	✓	✓	✓	✓
H130 GC			✓	✓	✓		
H130 GC S	✓	✓	✓	✓	✓	✓	✓
H130E S	✓	✓	✓	✓	✓	✓	✓
H140 GC			✓	✓	✓		
H140 GC S	✓	✓	✓	✓*	✓	✓	✓*
H140E S	✓	✓	✓	✓	✓	✓	✓

335F CR

Pin-on

Undercarriage	L		
Counterweight	—		
Boom Type	Reach HD		
Stick Length	2.65 m HD (8'8")	3.20 m HD (10'6")	3.75 m HD (12'4")
H120E S	✓	✓	✓
H130 GC	✓	✓	✓
H130 GC S	✓	✓	✓
H130E S	✓	✓	✓
H140 GC	✓	✓	✓
H140 GC S	✓	✓	✓
H140E S	✓	✓	✓

(continued on next page)

Matching – Tracked Excavators *(continued)*

Match
 Working Range Front Only
 Allowed Usage on Machine Less Than 50%
 No Match

335F CR *(continued)*

Cat Pin Grabber Coupler

Undercarriage	L		
Counterweight	—		
Boom Type	Reach HD		
Stick Length	2.65 m HD (8'8")	3.20 m HD (10'6")	3.75 m HD (12'4")
H120E S	✓	✓	✓
H130 GC	✓	✓	✓
H130 GC S	✓	✓	✓
H130E S	✓	✓	✓
H140 GC	✓	✓	✓*
H140 GC S	✓	✓*	
H140E S	✓	✓	✓

CW-45 S Dedicated Coupler

Undercarriage	L	
Counterweight	—	
Boom Type	Reach HD	
Stick Length	2.65 m HD (8'8")	3.20 m HD (10'6")
H120E S	✓	✓
H130 GC S	✓	✓
H130E S	✓	✓
H140 GC S	✓	
H140E S	✓	✓

CW-45 Dedicated Coupler

Undercarriage	L	
Counterweight	—	
Boom Type	Reach HD	
Stick Length	2.65 m HD (8'8")	3.20 m HD (10'6")
H120E S	✓	✓
H130 GC S	✓	✓
H130E S	✓	✓
H140 GC S	✓	✓*
H140E S	✓	✓

336D2 GC

Pin-on

Undercarriage	—
Counterweight	—
Boom Type	Reach
Stick Length	2.80 m (9'2")
H140 GC	✓
H140 GC S	✓
H140E S	✓
H160E S	✓

(continued on next page)

Hammer Technical Specifications

Matching – Tracked Excavators *(continued)*

Match
 * Working Range Front Only
 † Allowed Usage on Machine Less Than 50%
 No Match

336D2 GC *(continued)*

Cat Pin Grabber Coupler

Undercarriage	—
Counterweight	—
Boom Type	Reach
Stick Length	2.80 m (9'2")
H140 GC	✓
H140 GC S	✓*
H140E S	✓

CW-45 S Dedicated Coupler

Undercarriage	—
Counterweight	—
Boom Type	Reach
Stick Length	2.80 m (9'2")
H140 GC	✓
H140 GC S	✓*
H140E S	✓

CW-45 Dedicated Coupler

Undercarriage	—
Counterweight	—
Boom Type	Reach
Stick Length	2.80 m (9'2")
H140 GC	✓
H140 GC S	✓*
H140E S	✓

336D2

Pin-on

Undercarriage	—		L					
Counterweight	—		—					
Boom Type	Reach HD		Reach HD				ME	
Stick Length	2.80 m HD (9'2")	3.20 m HD (10'6")	2.80 m HD (9'2")	3.20 m HD (10'6")	3.20 m (10'6")	3.90 m (12'10")	2.15 m (7'1")	2.55 m (8'4")
H140 GC	✓	✓	✓	✓	✓	✓	✓	✓
H140 GC S	✓	✓	✓	✓	✓	✓	✓	✓
H140E S			✓	✓	✓	✓	✓	✓
H160E S			✓	✓	✓	✓	✓	✓

Cat Pin Grabber Coupler

Undercarriage	—		L					
Counterweight	—		—					
Boom Type	Reach HD		Reach HD				ME	
Stick Length	2.80 m HD (9'2")	3.20 m HD (10'6")	2.80 m HD (9'2")	3.20 m HD (10'6")	3.20 m (10'6")	3.90 m (12'10")	2.15 m (7'1")	2.55 m (8'4")
H140 GC	✓	✓	✓	✓	✓	✓*	✓	✓
H140 GC S	✓*	✓*	✓	✓*	✓		✓	✓
H140E S			✓	✓	✓	✓	✓	✓
H160E S			✓	✓*	✓*		✓	✓*

(continued on next page)

Matching – Tracked Excavators *(continued)*

Match
 Working Range Front Only
 Allowed Usage on Machine Less Than 50%
 No Match

336D2 *(continued)*

CW-45 S Dedicated Coupler

Undercarriage	L			
Counterweight	—			
Boom Type	Reach HD		ME	
Stick Length	3.20 m HD (10'6")	3.90 m (12'10")	2.15 m (7'1")	2.55 m (8'4")
H140 GC	✓	✓*	✓	✓
H140 GC S	✓*		✓	✓
H140E S	✓	✓	✓	✓
H160E S	✓*		✓	✓

CW-45 Dedicated Coupler

Undercarriage	L				
Counterweight	—				
Boom Type	Reach HD			ME	
Stick Length	3.20 m HD (10'6")	3.20 m (10'6")	3.90 m (12'10")	2.15 m (7'1")	2.55 m (8'4")
H140 GC	✓	✓	✓*	✓	✓
H140 GC S	✓*	✓		✓	✓
H140E S	✓	✓	✓	✓	✓
H160E S	✓*	✓		✓	✓

336D2 XE

Pin-on

Undercarriage	—		L					
Counterweight	—		—					
Boom Type	Reach HD		Reach HD				ME	
Stick Length	2.80 m HD (9'2")	3.20 m HD (10'6")	2.80 m HD (9'2")	3.20 m HD (10'6")	3.20 m (10'6")	3.90 m (12'10")	2.15 m (7'1")	2.55 m (8'4")
H140 GC	✓	✓	✓	✓	✓	✓	✓	✓
H140 GC S	✓	✓	✓	✓	✓	✓	✓	✓
H140E S			✓	✓	✓	✓	✓	✓
H160E S			✓	✓	✓	✓	✓	✓

Cat Pin Grabber Coupler

Undercarriage	—		L		
Counterweight	—		—		
Boom Type	Reach HD		Reach HD	ME	
Stick Length	2.80 m HD (9'2")	3.20 m HD (10'6")	3.20 m (10'6")	2.15 m (7'1")	2.55 m (8'4")
H140 GC	✓	✓	✓	✓	✓
H140 GC S	✓*	✓*	✓	✓	✓
H140E S			✓	✓	✓
H160E S			✓*	✓	✓*

(continued on next page)

Hammer Technical Specifications

Matching – Tracked Excavators *(continued)*

Match
 Working Range Front Only
 Allowed Usage on Machine Less Than 50%
 No Match

336D2 XE *(continued)*

CW-45 Dedicated Coupler

Undercarriage	L		
Counterweight	—		
Boom Type	Reach HD	ME	
Stick Length	3.20 m (10'6")	2.15 m (7'1")	2.55 m (8'4")
H140 GC	✓	✓	✓
H140 GC S	✓	✓	✓
H140E S	✓	✓	✓
H160E S	✓	✓	✓

336F

Pin-on

Undercarriage	L			
Counterweight	6.0 mt			
Boom Type	Reach HD			ME
Stick Length	2.80 m HD (9'2")	3.20 m HD (10'6")	3.90 m HD (12'10")	2.55 m (8'4")
H140 GC	✓	✓	✓	✓
H140 GC S	✓	✓	✓	✓
H140E S	✓	✓	✓	✓
H160E S	✓	✓	✓	✓

Pin-on *(continued)*

Undercarriage	L							
Counterweight	7.0 mt						8.45 mt	
Boom Type	Reach ES		Reach HD			ME	Straight	
Stick Length	3.20 m ES (10'6")	3.90 m ES (12'10")	2.80 m HD (9'2")	3.20 m HD (10'6")	3.90 m HD (12'10")	2.55 m (8'4")	3.20 m HD (10'6")	3.90 m HD (12'10")
H140 GC	✓	✓		✓	✓	✓		
H140 GC S	✓	✓	✓	✓	✓	✓	✓	✓
H140E S	✓	✓	✓	✓	✓	✓	✓	✓
H160E S	✓	✓	✓	✓	✓	✓	✓	✓

Pin-on *(continued)*

Undercarriage	LN						
Counterweight	7.0 mt				8.45 mt		
Boom Type	Reach HD			ME	Straight		
Stick Length	2.80 m HD (9'2")	3.20 m HD (10'6")	3.90 m HD (12'10")	2.55 m (8'4")	3.20 m HD (10'6")	3.90 m HD (12'10")	
H140 GC							
H140 GC S	✓	✓	✓	✓	✓	✓	
H140E S	✓	✓	✓	✓	✓	✓	
H160E S	✓	✓	✓	✓	✓	✓	

(continued on next page)

Hammer Technical Specifications

Matching – Tracked Excavators *(continued)*

Match
 Working Range Front Only
 Allowed Usage on Machine Less Than 50%
 No Match

336F *(continued)*

Cat Pin Grabber Coupler

Undercarriage	L			
Counterweight	6.0 mt			
Boom Type	Reach HD			ME
Stick Length	2.80 m HD (9'2")	3.20 m HD (10'6")	3.90 m HD (12'10")	2.55 m (8'4")
H140 GC	✓	✓	✓	✓
H140 GC S	✓	✓	✓*	✓
H140E S	✓	✓	✓	✓
H160E S	✓	✓	✓*	✓

Cat Pin Grabber Coupler *(continued)*

Undercarriage	L							
Counterweight	7.0 mt						8.45 mt	
Boom Type	Reach ES		Reach HD			ME	Straight	
Stick Length	3.20 m ES (10'6")	3.90 m ES (12'10")	2.80 m HD (9'2")	3.20 m HD (10'6")	3.90 m HD (12'10")	2.55 m (8'4")	3.20 m HD (10'6")	3.90 m HD (12'10")
H140 GC	✓	✓		✓	✓	✓		
H140 GC S	✓	✓	✓	✓	✓	✓	✓	✓
H140E S	✓	✓	✓	✓	✓	✓	✓	✓
H160E S	✓	✓	✓	✓	✓	✓		

Cat Pin Grabber Coupler *(continued)*

Undercarriage	LN						
Counterweight	7.0 mt				8.45 mt		
Boom Type	Reach HD			ME	Straight		
Stick Length	2.80 m HD (9'2")	3.20 m HD (10'6")	3.90 m HD (12'10")	2.55 m (8'4")	3.20 m HD (10'6")	3.90 m HD (12'10")	
H140 GC							
H140 GC S	✓	✓	✓*	✓	✓	✓	
H140E S	✓	✓	✓	✓	✓	✓	
H160E S	✓	✓	✓*	✓			

CW-45 S Dedicated Coupler

Undercarriage	L						
Counterweight	7.0 mt				8.45 mt		
Boom Type	Reach HD			ME	Straight		
Stick Length	2.80 m HD (9'2")	3.20 m HD (10'6")	3.90 m HD (12'10")	2.55 m (8'4")	3.20 m HD (10'6")	3.90 m HD (12'10")	
H140 GC S	✓	✓	✓	✓			
H140E S	✓	✓	✓	✓	✓	✓	
H160E S	✓	✓	✓	✓			

(continued on next page)

Hammer Technical Specifications

Matching – Tracked Excavators *(continued)*

Match
 Working Range Front Only
 Allowed Usage on Machine Less Than 50%
 No Match

336F *(continued)*

CW-45 S Dedicated Coupler *(continued)*

Undercarriage	LN					
Counterweight	7.0 mt			8.45 mt		
Boom Type	Reach HD			ME	Straight	
Stick Length	2.80 m HD (9'2")	3.20 m HD (10'6")	3.90 m HD (12'10")	2.55 m (8'4")	3.20 m HD (10'6")	3.90 m HD (12'10")
H140 GC S	✓	✓	✓*	✓		
H140E S	✓	✓	✓	✓	✓	✓
H160E S	✓	✓	✓*	✓		

CW-45 Dedicated Coupler

Undercarriage	L					
Counterweight	7.0 mt			8.45 mt		
Boom Type	Reach HD			ME	Straight	
Stick Length	2.80 m HD (9'2")	3.20 m HD (10'6")	3.90 m HD (12'10")	2.55 m (8'4")	3.20 m HD (10'6")	3.90 m HD (12'10")
H140 GC S	✓	✓	✓	✓		
H140E S	✓	✓	✓	✓	✓	✓
H160E S	✓	✓	✓	✓		

CW-45 Dedicated Coupler *(continued)*

Undercarriage	LN					
Counterweight	7.0 mt			8.45 mt		
Boom Type	Reach HD			ME	Straight	
Stick Length	2.80 m HD (9'2")	3.20 m HD (10'6")	3.90 m HD (12'10")	2.55 m (8'4")	3.20 m HD (10'6")	3.90 m HD (12'10")
H140 GC S	✓	✓	✓	✓		
H140E S	✓	✓	✓	✓	✓	✓
H160E S	✓	✓	✓*	✓		

336F XE

Pin-on

Undercarriage	L				
Counterweight	5.05 mt				
Boom Type	Reach HD				
Stick Length	2.55 m (8'4")	2.80 m HD (9'2")	3.20 m HD (10'6")	3.90 m HD (12'10")	
H140 GC	✓	✓	✓	✓	
H140 GC S	✓	✓	✓	✓	
H140E S	✓	✓	✓	✓	
H160E S	✓	✓	✓	✓	

(continued on next page)

Matching – Tracked Excavators (continued)

Match
 * Working Range Front Only
 † Allowed Usage on Machine Less Than 50%
 No Match

336F XE (continued)

Pin-on (continued)

Undercarriage	L					
Counterweight	6.05 mt					
Boom Type	Reach ES		Reach HD			ME
Stick Length	3.20 m ES (10'6")	3.90 m ES (12'10")	2.80 m HD (9'2")	3.20 m HD (10'6")	3.90 m HD (12'10")	2.55 m (8'4")
H140 GC	✓	✓	✓	✓	✓	✓
H140 GC S	✓	✓	✓	✓	✓	✓
H140E S	✓	✓	✓	✓	✓	✓
H160E S	✓	✓	✓	✓	✓	✓

Pin-on (continued)

Undercarriage	LN			
Counterweight	6.05 mt			
Boom Type	Reach HD			ME
Stick Length	2.80 m HD (9'2")	3.20 m HD (10'6")	3.90 m HD (12'10")	2.55 m (8'4")
H140 GC				
H140 GC S	✓	✓	✓	✓
H140E S	✓	✓	✓	✓
H160E S	✓	✓	✓	✓

Cat Pin Grabber Coupler

Undercarriage	L			
Counterweight	5.05 mt			
Boom Type	Reach HD			
Stick Length	2.55 m (8'4")	2.80 m HD (9'2")	3.20 m HD (10'6")	3.90 m HD (12'10")
H140 GC	✓	✓	✓	✓
H140 GC S	✓	✓	✓	✓*
H140E S	✓	✓	✓	✓
H160E S	✓	✓	✓	✓*

Cat Pin Grabber Coupler (continued)

Undercarriage	L					
Counterweight	6.05 mt					
Boom Type	Reach ES		Reach HD			ME
Stick Length	3.20 m ES (10'6")	3.90 m ES (12'10")	2.80 m HD (9'2")	3.20 m HD (10'6")	3.90 m HD (12'10")	2.55 m (8'4")
H140 GC	✓	✓	✓	✓	✓	✓
H140 GC S	✓	✓	✓	✓	✓	✓
H140E S	✓	✓	✓	✓	✓	✓
H160E S	✓	✓	✓	✓	✓	✓

(continued on next page)

Hammer Technical Specifications

Matching – Tracked Excavators (continued)

Match
 * Working Range Front Only
 † Allowed Usage on Machine Less Than 50%
 No Match

336F XE (continued)

Cat Pin Grabber Coupler (continued)

Undercarriage	LN			
Counterweight	6.05 mt			
Boom Type	Reach HD			ME
Stick Length	2.80 m HD (9'2")	3.20 m HD (10'6")	3.90 m HD (12'10")	2.55 m (8'4")
H140 GC				
H140 GC S	✓	✓	✓*	✓
H140E S	✓	✓	✓	✓
H160E S	✓	✓	✓*	✓

CW-45 S Dedicated Coupler

Undercarriage	L				LN			
Counterweight	6.05 mt				6.05 mt			
Boom Type	Reach HD			ME	Reach HD			ME
Stick Length	2.80 m HD (9'2")	3.20 m HD (10'6")	3.90 m HD (12'10")	2.55 m (8'4")	2.80 m HD (9'2")	3.20 m HD (10'6")	3.90 m HD (12'10")	2.55 m (8'4")
H140 GC S	✓	✓	✓	✓	✓	✓	✓*	✓
H140E S	✓	✓	✓	✓	✓	✓	✓	✓
H160E S	✓	✓	✓	✓	✓	✓	✓*	✓

CW-45 Dedicated Coupler

Undercarriage	L				LN			
Counterweight	6.05 mt				6.05 mt			
Boom Type	Reach HD			ME	Reach HD			ME
Stick Length	2.80 m HD (9'2")	3.20 m HD (10'6")	3.90 m HD (12'10")	2.55 m (8'4")	2.80 m HD (9'2")	3.20 m HD (10'6")	3.90 m HD (12'10")	2.55 m (8'4")
H140 GC S	✓	✓	✓	✓	✓	✓	✓	✓
H140E S	✓	✓	✓	✓	✓	✓	✓	✓
H160E S	✓	✓	✓	✓	✓	✓	✓*	✓

336 GC

Pin-on

Undercarriage	—			L			LN	
Counterweight	6.8 mt			6.8 mt			6.8 mt	
Boom Type	Reach			Reach			Reach	
Stick Length	2.80 m (9'2")	3.20 m (10'6")	3.90 m (12'10")	2.80 m (9'2")	3.20 m (10'6")	3.90 m (12'10")	2.80 m (9'2")	3.20 m (10'6")
H140 GC	✓	✓	✓	✓	✓	✓		
H140 GC S	✓	✓	✓	✓	✓	✓	✓	✓
H140E S	✓	✓	✓	✓	✓	✓	✓	✓
H160E S	✓	✓	✓	✓	✓	✓	✓	✓

(continued on next page)

Matching – Tracked Excavators *(continued)*

Match
 Working Range Front Only
 Allowed Usage on Machine Less Than 50%
 No Match

336 GC *(continued)*

Cat Pin Grabber Coupler

Undercarriage	—			L			LN	
Counterweight	6.8 mt			6.8 mt			6.8 mt	
Boom Type	Reach			Reach			Reach	
Stick Length	2.80 m (9'2")	3.20 m (10'6")	3.90 m (12'10")	2.80 m (9'2")	3.20 m (10'6")	3.90 m (12'10")	2.80 m (9'2")	3.20 m (10'6")
H140 GC	✓	✓	✓*	✓	✓	✓		
H140 GC S	✓	✓		✓	✓		✓	✓*
H140E S	✓	✓	✓	✓	✓	✓	✓	✓
H160E S	✓	✓		✓	✓		✓	✓*

CW-45 S Dedicated Coupler

Undercarriage	—		L		LN	
Counterweight	6.8 mt		6.8 mt		6.8 mt	
Boom Type	Reach		Reach		Reach	
Stick Length	2.80 m (9'2")	3.20 m (10'6")	2.80 m (9'2")	3.20 m (10'6")	2.80 m (9'2")	3.20 m (10'6")
H140 GC	✓	✓				
H140 GC S	✓	✓	✓	✓	✓	✓*
H140E S	✓	✓	✓	✓	✓	✓
H160E S	✓	✓	✓	✓	✓	✓*

CW-45 Dedicated Coupler

Undercarriage	—		L		LN	
Counterweight	6.8 mt		6.8 mt		6.8 mt	
Boom Type	Reach		Reach		Reach	
Stick Length	2.80 m (9'2")	3.20 m (10'6")	2.80 m (9'2")	3.20 m (10'6")	2.80 m (9'2")	3.20 m (10'6")
H140 GC	✓	✓				
H140 GC S	✓	✓	✓	✓	✓	✓
H140E S	✓	✓	✓	✓	✓	✓
H160E S	✓	✓	✓	✓	✓	✓*

336

Pin-on

Undercarriage	L					
Counterweight	6.8 mt					
Boom Type	Reach			Reach HD		ME
Stick Length	2.80 m (9'2")	3.20 m (10'6")	3.90 m (12'10")	2.80 m HD (9'2")	3.20 m HD (10'6")	2.55 m (8'4")
H140 GC	✓	✓	✓	✓	✓	✓
H140 GC S	✓	✓	✓	✓	✓	✓
H140E S	✓	✓	✓	✓	✓	✓
H160E S	✓	✓	✓	✓	✓	✓

(continued on next page)

Hammer Technical Specifications

Matching – Tracked Excavators *(continued)*

Match
 * Working Range Front Only
 † Allowed Usage on Machine Less Than 50%
 No Match

336 *(continued)*

Pin-on *(continued)*

Undercarriage	L						
Counterweight	7.5 mt						
Boom Type	Reach			Reach HD			ME
Stick Length	2.80 m (9'2")	3.20 m (10'6")	3.90 m (12'10")	2.80 m HD (9'2")	3.20 m HD (10'6")	3.90 m HD (12'10")	2.55 m (8'4")
H140 GC	✓	✓	✓	✓	✓	✓	✓
H140 GC S	✓	✓	✓	✓	✓	✓	✓
H140E S	✓	✓	✓		✓	✓	✓
H160E S	✓	✓	✓		✓	✓	✓

Pin-on *(continued)*

Undercarriage	LN					
Counterweight	7.5 mt					
Boom Type	Reach			Reach HD		ME
Stick Length	2.80 m (9'2")	3.20 m (10'6")	3.90 m (12'10")	3.20 m HD (10'6")	3.90 m HD (12'10")	2.55 m (8'4")
H140 GC						
H140 GC S	✓	✓	✓	✓	✓	✓
H140E S	✓	✓	✓	✓	✓	✓
H160E S	✓	✓	✓	✓	✓	✓

Cat Pin Grabber Coupler

Undercarriage	L					
Counterweight	6.8 mt					
Boom Type	Reach			Reach HD		ME
Stick Length	2.80 m (9'2")	3.20 m (10'6")	3.90 m (12'10")	2.80 m HD (9'2")	3.20 m HD (10'6")	2.55 m (8'4")
H140 GC	✓	✓	✓	✓	✓	✓
H140 GC S	✓	✓	✓	✓	✓	✓
H140E S	✓	✓	✓	✓	✓	✓
H160E S	✓	✓	✓*	✓	✓	✓

Cat Pin Grabber Coupler *(continued)*

Undercarriage	L						
Counterweight	7.5 mt						
Boom Type	Reach			Reach HD			ME
Stick Length	2.80 m (9'2")	3.20 m (10'6")	3.90 m (12'10")	2.80 m HD (9'2")	3.20 m HD (10'6")	3.90 m HD (12'10")	2.55 m (8'4")
H140 GC	✓	✓	✓	✓	✓	✓	✓
H140 GC S	✓	✓	✓	✓	✓	✓	✓
H140E S	✓	✓	✓		✓	✓	✓
H160E S	✓	✓	✓		✓	✓	✓

(continued on next page)

Matching – Tracked Excavators *(continued)*

Match
 Working Range Front Only
 Allowed Usage on Machine Less Than 50%
 No Match

336 *(continued)*

Cat Pin Grabber Coupler *(continued)*

Undercarriage	LN					
Counterweight	7.5 mt					
Boom Type	Reach			Reach HD		ME
Stick Length	2.80 m (9'2")	3.20 m (10'6")	3.90 m (12'10")	3.20 m HD (10'6")	3.90 m HD (12'10")	2.55 m (8'4")
H140 GC						
H140 GC S	✓	✓	✓*	✓	✓*	✓
H140E S	✓	✓	✓	✓	✓	✓
H160E S	✓	✓	✓*	✓		✓

CW-45 S Dedicated Coupler

Undercarriage	L						
Counterweight	6.8 mt			7.5 mt			
Boom Type	Reach HD	ME	Reach			Reach HD	ME
Stick Length	3.20 m HD (10'6")	2.55 m (8'4")	2.80 m (9'2")	3.20 m (10'6")	3.90 m (12'10")	3.20 m HD (10'6")	2.55 m (8'4")
H140 GC	✓	✓				✓	✓
H140 GC S	✓	✓	✓	✓	✓	✓	✓
H140E S	✓	✓	✓	✓	✓	✓	✓
H160E S	✓	✓	✓	✓	✓	✓	✓

CW-45 S Dedicated Coupler *(continued)*

Undercarriage	LN					
Counterweight	7.5 mt					
Boom Type	Reach			Reach HD		ME
Stick Length	2.80 m (9'2")	3.20 m (10'6")	3.90 m (12'10")	3.20 m HD (10'6")	3.90 m HD (12'10")	2.55 m (8'4")
H140 GC						
H140 GC S	✓	✓	✓*	✓	✓*	✓
H140E S	✓	✓	✓	✓	✓	✓
H160E S	✓	✓	✓*	✓		✓

CW-45 Dedicated Coupler

Undercarriage	L							
Counterweight	6.8 mt			7.5 mt				
Boom Type	Reach HD		ME	Reach			Reach HD	ME
Stick Length	2.80 m HD (9'2")	3.20 m HD (10'6")	2.55 m (8'4")	2.80 m (9'2")	3.20 m (10'6")	3.90 m (12'10")	3.20 m HD (10'6")	2.55 m (8'4")
H140 GC	✓	✓	✓				✓	✓
H140 GC S	✓	✓	✓	✓	✓	✓	✓	✓
H140E S	✓	✓	✓	✓	✓	✓	✓	✓
H160E S	✓	✓	✓	✓	✓	✓	✓	✓

(continued on next page)

Hammer Technical Specifications

Matching – Tracked Excavators (continued)

Match
 Working Range Front Only
 Allowed Usage on Machine Less Than 50%
 No Match

336 (continued)

CW-45 Dedicated Coupler (continued)

Undercarriage	LN					
Counterweight	7.5 mt					
Boom Type	Reach			Reach HD		ME
Stick Length	2.80 m (9'2")	3.20 m (10'6")	3.90 m (12'10")	3.20 m HD (10'6")	3.90 m HD (12'10")	2.55 m (8'4")
H140 GC						
H140 GC S	✓	✓	✓*	✓	✓*	✓
H140E S	✓	✓	✓	✓	✓	✓
H160E S	✓	✓	✓*	✓		✓

340D2

Pin-on

Undercarriage	L							
Counterweight	—				8.5 mt			
Boom Type	Reach HD		ME		Reach HD		ME	
Stick Length	2.80 m HD (9'2")	3.20 m HD (10'6")	2.15 m (7'1")	2.55 m (8'4")	2.80 m HD (9'2")	3.20 m HD (10'6")	2.15 m (7'1")	2.55 m (8'4")
H140 GC	✓	✓	✓	✓	✓	✓	✓	✓
H140 GC S	✓	✓	✓	✓	✓	✓	✓	✓
H140E S		✓	✓	✓	✓	✓	✓	✓
H160E S		✓	✓	✓	✓	✓	✓	✓
H180E S		✓	✓	✓	✓	✓	✓	✓

Cat Pin Grabber Coupler

Undercarriage	L							
Counterweight	—				8.5 mt			
Boom Type	Reach HD		ME		Reach HD		ME	
Stick Length	2.80 m HD (9'2")	3.20 m HD (10'6")	2.15 m (7'1")	2.55 m (8'4")	3.20 m HD (10'6")	2.15 m (7'1")	2.55 m (8'4")	
H140 GC	✓	✓	✓	✓	✓	✓	✓	
H140 GC S	✓	✓	✓	✓	✓	✓	✓	
H140E S		✓	✓	✓	✓	✓	✓	
H160E S		✓	✓	✓	✓	✓	✓	
H180E S		✓*	✓	✓	✓	✓	✓	

CW-45 S Dedicated Coupler

Undercarriage	L						
Counterweight	—			8.5 mt			
Boom Type	Reach HD		ME		Reach HD		ME
Stick Length	3.20 m HD (10'6")	2.15 m (7'1")	2.55 m (8'4")	3.20 m HD (10'6")	2.15 m (7'1")	2.55 m (8'4")	
H140 GC	✓	✓	✓	✓	✓	✓	
H140 GC S	✓	✓	✓	✓	✓	✓	
H140E S	✓	✓	✓	✓	✓	✓	
H160E S	✓	✓	✓	✓	✓	✓	
H180E S	✓	✓	✓	✓	✓	✓	

(continued on next page)

Matching – Tracked Excavators *(continued)*

Match
 Working Range Front Only
 Allowed Usage on Machine Less Than 50%
 No Match

340D2 *(continued)*

CW-45 Dedicated Coupler

Undercarriage	L					
Counterweight	8.5 mt					
Boom Type	Reach HD	ME		Reach HD	ME	
Stick Length	3.20 m HD (10'6")	2.15 m (7'1")	2.55 m (8'4")	3.20 m HD (10'6")	2.15 m (7'1")	2.55 m (8'4")
H140 GC	✓	✓	✓	✓	✓	✓
H140 GC S	✓	✓	✓	✓	✓	✓
H140E S	✓	✓	✓	✓	✓	✓
H160E S	✓	✓	✓	✓	✓	✓
H180E S	✓	✓	✓	✓	✓	✓

340F

Pin-on

Undercarriage	L		
Counterweight	7.0 mt		
Boom Type	Reach HD	ME	
Stick Length	2.80 m HD (9'2")	3.20 m HD (10'6")	2.55 m (8'4")
H140 GC S	✓	✓	✓
H140E S	✓	✓	✓
H160E S	✓	✓	✓
H180E S	✓†	✓†	✓†

Cat Pin Grabber Coupler

Undercarriage	L		
Counterweight	7.0 mt		
Boom Type	Reach HD	ME	
Stick Length	2.80 m HD (9'2")	3.20 m HD (10'6")	2.55 m (8'4")
H140 GC S	✓	✓	✓
H140E S	✓	✓	✓
H160E S	✓	✓	✓

CW-45 S Dedicated Coupler

Undercarriage	L		
Counterweight	7.0 mt		
Boom Type	Reach HD	ME	
Stick Length	2.80 m HD (9'2")	3.20 m HD (10'6")	2.55 m (8'4")
H140 GC S	✓	✓	✓
H140E S	✓	✓	✓
H160E S	✓	✓	✓

CW-45 Dedicated Coupler

Undercarriage	L		
Counterweight	7.0 mt		
Boom Type	Reach HD	ME	
Stick Length	2.80 m HD (9'2")	3.20 m HD (10'6")	2.55 m (8'4")
H140 GC S	✓	✓	✓
H140E S	✓	✓	✓
H160E S	✓	✓	✓

(continued on next page)

Hammer Technical Specifications

Matching – Tracked Excavators *(continued)*

Match
 * Working Range Front Only
 † Allowed Usage on Machine Less Than 50%
 No Match

340F UHD

Pin-on

Undercarriage	L-FIX					
Counterweight	8.45 mt					
Boom Type	Retrofit (B)			Retrofit (S)		
Stick Length	2.80 m HD (9'2")	3.20 m HD (10'6")	3.90 m HD (12'10")	2.80 m HD (9'2")	3.20 m HD (10'6")	3.90 m HD (12'10")
H140 GC S	✓	✓	✓	✓	✓	✓
H140E S	✓	✓	✓	✓	✓	✓
H160E S	✓	✓	✓	✓	✓	✓
H180E S	✓†	✓†	✓†			

Pin-on *(continued)*

Undercarriage	L-VG					
Counterweight	8.45 mt					
Boom Type	Retrofit (B)			Retrofit (S)		
Stick Length	2.80 m HD (9'2")	3.20 m HD (10'6")	3.90 m HD (12'10")	2.80 m HD (9'2")	3.20 m HD (10'6")	3.90 m HD (12'10")
H140 GC S	✓	✓	✓	✓	✓	✓
H140E S	✓	✓	✓	✓	✓	✓
H160E S	✓	✓	✓	✓	✓	✓
H180E S	✓†	✓†	✓†			

Cat Pin Grabber Coupler

Undercarriage	L-FIX					
Counterweight	8.45 mt					
Boom Type	Retrofit (B)			Retrofit (S)		
Stick Length	2.80 m HD (9'2")	3.20 m HD (10'6")	3.90 m HD (12'10")	2.80 m HD (9'2")	3.20 m HD (10'6")	3.90 m HD (12'10")
H140 GC S	✓	✓	✓	✓	✓*	
H140E S	✓	✓	✓	✓	✓	✓
H160E S	✓	✓	✓			

Cat Pin Grabber Coupler *(continued)*

Undercarriage	L-VG					
Counterweight	8.45 mt					
Boom Type	Retrofit (B)			Retrofit (S)		
Stick Length	2.80 m HD (9'2")	3.20 m HD (10'6")	3.90 m HD (12'10")	2.80 m HD (9'2")	3.20 m HD (10'6")	3.90 m HD (12'10")
H140 GC S	✓	✓	✓	✓	✓	✓
H140E S	✓	✓	✓	✓	✓	✓
H160E S	✓	✓	✓			

(continued on next page)

Matching – Tracked Excavators *(continued)*

Match
 Working Range Front Only
 Allowed Usage on Machine Less Than 50%
 No Match

340F UHD *(continued)*

CW-45 S Dedicated Coupler

Undercarriage	L-FIX					
Counterweight	8.45 mt					
Boom Type	Retrofit (B)			Retrofit (S)		
Stick Length	2.80 m HD (9'2")	3.20 m HD (10'6")	3.90 m HD (12'10")	2.80 m HD (9'2")	3.20 m HD (10'6")	3.90 m HD (12'10")
H140 GC S	✓	✓	✓		✓	
H140E S	✓	✓	✓	✓	✓	✓
H160E S	✓	✓	✓			

CW-45 S Dedicated Coupler *(continued)*

Undercarriage	L-VG					
Counterweight	8.45 mt					
Boom Type	Retrofit (B)			Retrofit (S)		
Stick Length	2.80 m HD (9'2")	3.20 m HD (10'6")	3.90 m HD (12'10")	2.80 m HD (9'2")	3.20 m HD (10'6")	3.90 m HD (12'10")
H140 GC S	✓	✓	✓		✓	
H140E S	✓	✓	✓	✓	✓	✓
H160E S	✓	✓	✓			

CW-45 Dedicated Coupler

Undercarriage	L-FIX					
Counterweight	8.45 mt					
Boom Type	Retrofit (B)			Retrofit (S)		
Stick Length	2.80 m HD (9'2")	3.20 m HD (10'6")	3.90 m HD (12'10")	2.80 m HD (9'2")	3.20 m HD (10'6")	3.90 m HD (12'10")
H140 GC S	✓	✓	✓		✓	
H140E S	✓	✓	✓	✓	✓	✓
H160E S	✓	✓	✓			

CW-45 Dedicated Coupler *(continued)*

Undercarriage	L-VG					
Counterweight	8.45 mt					
Boom Type	Retrofit (B)			Retrofit (S)		
Stick Length	2.80 m HD (9'2")	3.20 m HD (10'6")	3.90 m HD (12'10")	2.80 m HD (9'2")	3.20 m HD (10'6")	3.90 m HD (12'10")
H140 GC S	✓	✓	✓		✓	✓
H140E S	✓	✓	✓	✓	✓	✓
H160E S	✓	✓	✓			

(continued on next page)

Hammer Technical Specifications

Matching – Tracked Excavators (continued)

Match
 * Working Range Front Only
 † Allowed Usage on Machine Less Than 50%
 No Match

340

Pin-on

Undercarriage	L		LN		HD High Wide			
Counterweight	9.0 mt		9.0 mt		7.5 mt			
Boom Type	Straight		Straight		Reach			ME
Stick Length	3.20 m (10'6")	3.90 m (12'10")	3.20 m (10'6")	3.90 m (12'10")	2.80 m (9'2")	3.20 m (10'6")	3.90 m (12'10")	2.55 m (8'4")
H140 GC	✓	✓						
H140 GC S	✓	✓	✓	✓	✓	✓	✓	✓
H140E S	✓	✓	✓	✓	✓	✓	✓	✓
H160E S	✓	✓	✓	✓	✓	✓	✓	✓

Cat Pin Grabber Coupler

Undercarriage	L		LN		HD High Wide			
Counterweight	9.0 mt		9.0 mt		7.5 mt			
Boom Type	Straight		Straight		Reach			ME
Stick Length	3.20 m (10'6")	3.90 m (12'10")	3.20 m (10'6")	3.90 m (12'10")	2.80 m (9'2")	3.20 m (10'6")	3.90 m (12'10")	2.55 m (8'4")
H140 GC	✓	✓						
H140 GC S	✓	✓	✓	✓*	✓	✓	✓	✓
H140E S	✓	✓	✓	✓	✓	✓	✓	✓
H160E S					✓	✓	✓	✓

CW-45 S Dedicated Coupler

Undercarriage	L		LN		HD High Wide			
Counterweight	9.0 mt		9.0 mt		7.5 mt			
Boom Type	Straight		Straight		Reach			ME
Stick Length	3.20 m (10'6")	3.90 m (12'10")	3.20 m (10'6")	3.90 m (12'10")	2.80 m (9'2")	3.20 m (10'6")	3.90 m (12'10")	2.55 m (8'4")
H140 GC S					✓	✓	✓	✓
H140E S	✓	✓	✓	✓	✓	✓	✓	✓
H160E S					✓	✓	✓	✓

CW-45 Dedicated Coupler

Undercarriage	L		LN		HD High Wide			
Counterweight	9.0 mt		9.0 mt		7.5 mt			
Boom Type	Straight		Straight		Reach			ME
Stick Length	3.20 m (10'6")	3.90 m (12'10")	3.20 m (10'6")	3.90 m (12'10")	2.80 m (9'2")	3.20 m (10'6")	3.90 m (12'10")	2.55 m (8'4")
H140 GC S					✓	✓	✓	✓
H140E S	✓	✓	✓	✓	✓	✓	✓	✓
H160E S					✓	✓	✓	✓

(continued on next page)

Matching – Tracked Excavators *(continued)*

Match
 Working Range Front Only
 Allowed Usage on Machine Less Than 50%
 No Match

345 GC

Pin-on

Undercarriage	—			
Counterweight	9.0 mt			
Boom Type	Reach HD		ME	
Stick Length	2.90 m HD (9'6")	3.35 m HD (11'0")	2.50 m (8'2")	3.00 m (9'10")
H160E S	✓	✓	✓	✓
H180E S	✓	✓	✓	✓

Cat Pin Grabber Coupler

Undercarriage	—	
Counterweight	9.0 mt	
Boom Type	Reach HD	
Stick Length	2.90 m HD (9'6")	3.35 m HD (11'0")
H160E S	✓	✓
H180E S	✓	✓*

CW-55 Dedicated Coupler

Undercarriage	—			
Counterweight	9.0 mt			
Boom Type	Reach HD		ME	
Stick Length	2.90 m HD (9'6")	3.35 m HD (11'0")	2.50 m (8'2")	3.00 m (9'10")
H160E S	✓	✓	✓	✓
H180E S	✓	✓*	✓	✓*

349D2

Pin-on

Undercarriage	—				L-FIX			
Counterweight	—				—			
Boom Type	Reach HD		ME		Reach HD		ME	
Stick Length	3.35 m HD (11'0")	3.90 m HD (12'10")	2.50 m (8'2")	3.00 m (9'10")	3.35 m HD (11'0")	3.90 m HD (12'10")	2.50 m (8'2")	3.00 m (9'10")
H160E S	✓	✓	✓	✓	✓	✓	✓	✓
H180E S	✓	✓	✓	✓	✓	✓	✓	✓

Cat Pin Grabber Coupler

Undercarriage	—		L-FIX	
Counterweight	—		—	
Boom Type	Reach HD		Reach HD	
Stick Length	3.35 m HD (11'0")	3.90 m HD (12'10")	3.35 m HD (11'0")	3.90 m HD (12'10")
H160E S	✓	✓	✓	✓
H180E S	✓	✓	✓	✓

(continued on next page)

Hammer Technical Specifications

Matching – Tracked Excavators *(continued)*

Match
 Working Range Front Only
 Allowed Usage on Machine Less Than 50%
 No Match

349D2 *(continued)*

CW-55 Dedicated Coupler

Undercarriage	—				L-FIX			
Counterweight	—				—			
Boom Type	Reach HD		ME		Reach HD		ME	
Stick Length	3.35 m HD (11'0")	3.90 m HD (12'10")	2.50 m (8'2")	3.00 m (9'10")	3.35 m HD (11'0")	3.90 m HD (12'10")	2.50 m (8'2")	3.00 m (9'10")
H160E S	✓	✓	✓	✓	✓	✓	✓	✓
H180E S	✓	✓	✓	✓	✓	✓	✓	✓

349F

Pin-on

Undercarriage	L-FIX				
Counterweight	—				
Boom Type	Long-Reach	Reach HD		ME	
Stick Length	4.30 m HD (14'1")	3.40 m HD (11'2")	3.90 m HD (12'10")	2.50 m (8'2")	3.00 m (9'10")
H160E S	✓	✓	✓	✓	✓
H180E S	✓	✓	✓	✓	✓

Cat Pin Grabber Coupler

Undercarriage	L-FIX		
Counterweight	—		
Boom Type	Long-Reach	Reach HD	
Stick Length	4.30 m HD (14'1")	3.40 m HD (11'2")	3.90 m HD (12'10")
H160E S	✓	✓	✓
H180E S	✓	✓	✓

349F XE

Pin-on

Undercarriage	L-FIX				
Counterweight	—				
Boom Type	Long-Reach	Reach HD		ME	
Stick Length	4.30 m HD (14'1")	3.40 m HD (11'2")	3.90 m HD (12'10")	2.50 m (8'2")	3.00 m (9'10")
H160E S	✓	✓	✓	✓	✓
H180E S	✓	✓	✓	✓	✓

Cat Pin Grabber Coupler

Undercarriage	L-FIX		
Counterweight	—		
Boom Type	Long-Reach	Reach HD	
Stick Length	4.30 m HD (14'1")	3.40 m HD (11'2")	3.90 m HD (12'10")
H160E S	✓	✓	✓
H180E S	✓	✓	✓

(continued on next page)

Matching – Tracked Excavators *(continued)*

Match
 Working Range Front Only
 Allowed Usage on Machine Less Than 50%
 No Match

349

Pin-on

Undercarriage	L					
Counterweight	9.0 mt					
Boom Type	Long-Reach	Reach HD			ME	
Stick Length	4.30 m HD (14'1")	2.90 m HD (9'6")	3.35 m HD (11'0")	3.90 m HD (12'10")	2.50 m (8'2")	3.00 m (9'10")
H160E S	✓	✓	✓	✓	✓	✓
H180E S	✓	✓	✓	✓	✓	✓

Cat Pin Grabber Coupler

Undercarriage	L				
Counterweight	9.0 mt				
Boom Type	Long-Reach	Reach HD			
Stick Length	4.30 m HD (14'1")	2.90 m HD (9'6")	3.35 m HD (11'0")	3.90 m HD (12'10")	
H160E S	✓	✓	✓	✓	
H180E S		✓	✓	✓	

CW-55 Dedicated Coupler

Undercarriage	L			
Counterweight	9.0 mt			
Boom Type	Reach HD		ME	
Stick Length	2.90 m HD (9'6")	3.35 m HD (11'0")	2.50 m (8'2")	3.00 m (9'10")
H160E S	✓	✓	✓	✓
H180E S	✓	✓	✓	✓

352F

Pin-on

Undercarriage	L-VG					
Counterweight	—					
Boom Type	Long-Reach	Reach HD			ME	
Stick Length	4.30 m HD (14'1")	2.90 m HD (9'6")	3.40 m HD (11'2")	3.90 m HD (12'10")	2.50 m (8'2")	3.00 m (9'10")
H160E S	✓	✓	✓	✓	✓	✓
H180E S	✓	✓	✓	✓	✓	✓

Cat Pin Grabber Coupler

Undercarriage	L-VG				
Counterweight	—				
Boom Type	Long-Reach	Reach HD			
Stick Length	4.30 m HD (14'1")	2.90 m HD (9'6")	3.40 m HD (11'2")	3.90 m HD (12'10")	
H160E S	✓	✓	✓	✓	
H180E S	✓	✓	✓	✓	

(continued on next page)

Hammer Technical Specifications

Matching – Tracked Excavators *(continued)*

Match
 * Working Range Front Only
 † Allowed Usage on Machine Less Than 50%
 No Match

352F *(continued)*

CW-55 Dedicated Coupler

Undercarriage	L-VG			
Counterweight	—			
Boom Type	Reach HD		ME	
Stick Length	2.90 m HD (9'6")	3.40 m HD (11'2")	2.50 m (8'2")	3.00 m (9'10")
H160E S	✓	✓	✓	✓
H180E S	✓	✓	✓	✓

352F XE

Pin-on

Undercarriage	L-VG					
Counterweight	—					
Boom Type	Long-Reach	Reach HD			ME	
Stick Length	4.30 m HD (14'1")	2.90 m HD (9'6")	3.40 m HD (11'2")	3.90 m HD (12'10")	2.50 m (8'2")	3.00 m (9'10")
H160E S	✓	✓	✓	✓	✓	✓
H180E S	✓	✓	✓	✓	✓	✓

Cat Pin Grabber Coupler

Undercarriage	L-VG			
Counterweight	—			
Boom Type	Long-Reach	Reach HD		
Stick Length	4.30 m HD (14'1")	2.90 m HD (9'6")	3.40 m HD (11'2")	3.90 m HD (12'10")
H160E S	✓	✓	✓	✓
H180E S	✓	✓	✓	✓

CW-55 Dedicated Coupler

Undercarriage	L-VG			
Counterweight	—			
Boom Type	Reach HD		ME	
Stick Length	2.90 m HD (9'6")	3.40 m HD (11'2")	2.50 m (8'2")	3.00 m (9'10")
H160E S	✓	✓	✓	✓
H180E S	✓	✓	✓	✓

352

Pin-on

Undercarriage	L-VG					
Counterweight	9.0 mt					
Boom Type	Long-Reach	Reach HD			ME	
Stick Length	4.30 m HD (14'1")	2.90 m HD (9'6")	3.35 m HD (11'0")	3.90 m HD (12'10")	2.50 m (8'2")	3.00 m (9'10")
H160E S	✓	✓	✓	✓	✓	✓
H180E S	✓	✓	✓	✓	✓	✓

(continued on next page)

Matching – Tracked Excavators *(continued)*

Match
 Working Range Front Only
 Allowed Usage on Machine Less Than 50%
 No Match

352 *(continued)*

Cat Pin Grabber Coupler

Undercarriage	L-VG			
Counterweight	9.0 mt			
Boom Type	Long-Reach	Reach HD		
Stick Length	4.30 m HD (14'1")	2.90 m HD (9'6")	3.35 m HD (11'0")	3.90 m HD (12'10")
H160E S	✓	✓	✓	✓
H180E S	✓*	✓	✓	✓

CW-55 Dedicated Coupler

Undercarriage	L-VG				
Counterweight	9.0 mt				
Boom Type	Long-Reach	Reach HD		ME	
Stick Length	4.30 m HD (14'1")	2.90 m HD (9'6")	3.35 m HD (11'0")	2.50 m (8'2")	3.00 m (9'10")
H160E S	✓	✓	✓	✓	✓
H180E S	✓	✓	✓	✓	✓

374F

Pin-on

Undercarriage	L					
Counterweight	—					
Boom Type	Reach				ME	
Stick Length	2.84 m HD (9'4")	3.60 m HD (11'10")	4.15 m HD (13'7")	4.67 m HD (15'4")	2.57 m (8'5")	3.00 m (9'10")
H180E S	✓	✓	✓	✓	✓	✓

CW-70 Dedicated Coupler

Undercarriage	L					
Counterweight	—					
Boom Type	Reach				ME	
Stick Length	2.84 m HD (9'4")	3.60 m HD (11'10")	4.15 m HD (13'7")	4.67 m HD (15'4")	2.57 m (8'5")	3.00 m (9'10")
H180E S	✓	✓	✓	✓	✓	✓

Hammer Technical Specifications

Matching – Wheeled Excavators

Match
 Working Range Front Only
 Allowed Usage on Machine Less Than 50%
 No Match

M314F

Pin-on

Undercarriage	Front and Rear Outriggers								
Counterweight	2.8 mt								
Boom Type	1 PC (short)			1 PC			VA		
Stick Length	2.00 m (6'7")	2.30 m (7'7")	2.60 m (8'6")	2.00 m (6'7")	2.30 m (7'7")	2.60 m (8'6")	2.00 m (6'7")	2.30 m (7'7")	2.60 m (8'6")
H110E S	✓	✓	✓	✓	✓	✓	✓	✓	✓
H115 GC	✓	✓	✓	✓	✓	✓	✓	✓	✓
H115 GC S	✓	✓	✓	✓	✓	✓	✓	✓	✓
H115E S	✓	✓	✓	✓	✓	✓	✓	✓	✓

Pin-on (continued)

Undercarriage	Front and Rear Outriggers								
Counterweight	3.3 mt								
Boom Type	1 PC (short)			1 PC			VA		
Stick Length	2.00 m (6'7")	2.30 m (7'7")	2.60 m (8'6")	2.00 m (6'7")	2.30 m (7'7")	2.60 m (8'6")	2.00 m (6'7")	2.30 m (7'7")	2.60 m (8'6")
H110E S	✓	✓	✓	✓	✓	✓	✓	✓	✓
H115 GC	✓	✓	✓	✓	✓	✓	✓	✓	✓
H115 GC S	✓	✓	✓	✓	✓	✓	✓	✓	✓
H115E S	✓	✓	✓	✓	✓	✓	✓	✓	✓

Pin-on (continued)

Undercarriage	Front Blade; Rear Outriggers								
Counterweight	2.8 mt								
Boom Type	1 PC (short)			1 PC			VA		
Stick Length	2.00 m (6'7")	2.30 m (7'7")	2.60 m (8'6")	2.00 m (6'7")	2.30 m (7'7")	2.60 m (8'6")	2.00 m (6'7")	2.30 m (7'7")	2.60 m (8'6")
H110E S	✓	✓	✓	✓	✓	✓	✓	✓	✓
H115 GC	✓	✓	✓	✓	✓	✓	✓	✓	✓
H115 GC S	✓	✓	✓	✓	✓	✓	✓	✓	✓
H115E S	✓	✓	✓	✓	✓	✓	✓	✓	✓

Pin-on (continued)

Undercarriage	Front Blade; Rear Outriggers								
Counterweight	3.3 mt								
Boom Type	1 PC (short)			1 PC			VA		
Stick Length	2.00 m (6'7")	2.30 m (7'7")	2.60 m (8'6")	2.00 m (6'7")	2.30 m (7'7")	2.60 m (8'6")	2.00 m (6'7")	2.30 m (7'7")	2.60 m (8'6")
H110E S	✓	✓	✓	✓	✓	✓	✓	✓	✓
H115 GC	✓	✓	✓	✓	✓	✓	✓	✓	✓
H115 GC S	✓	✓	✓	✓	✓	✓	✓	✓	✓
H115E S	✓	✓	✓	✓	✓	✓	✓	✓	✓

Pin-on (continued)

Undercarriage	Rear Blade								
Counterweight	2.8 mt								
Boom Type	1 PC (short)			1 PC			VA		
Stick Length	2.00 m (6'7")	2.30 m (7'7")	2.60 m (8'6")	2.00 m (6'7")	2.30 m (7'7")	2.60 m (8'6")	2.00 m (6'7")	2.30 m (7'7")	2.60 m (8'6")
H110E S	✓	✓	✓	✓	✓	✓	✓	✓	✓
H115 GC	✓	✓	✓	✓	✓	✓	✓	✓*	
H115 GC S	✓	✓	✓	✓	✓	✓	✓	✓	✓*
H115E S	✓	✓	✓	✓	✓	✓	✓	✓	✓

(continued on next page)

Matching – Wheeled Excavators (continued)

Match
 Working Range Front Only
 Allowed Usage on Machine Less Than 50%
 No Match

M314F (continued)

Pin-on (continued)

Undercarriage	Rear Blade								
Counterweight	3.3 mt								
Boom Type	1 PC (short)			1 PC			VA		
Stick Length	2.00 m (6'7")	2.30 m (7'7")	2.60 m (8'6")	2.00 m (6'7")	2.30 m (7'7")	2.60 m (8'6")	2.00 m (6'7")	2.30 m (7'7")	2.60 m (8'6")
H110E S	✓	✓	✓	✓	✓	✓	✓	✓	✓
H115 GC	✓	✓	✓	✓	✓	✓	✓	✓	✓
H115 GC S	✓	✓	✓	✓	✓	✓	✓	✓	✓
H115E S	✓	✓	✓	✓	✓	✓	✓	✓	✓

Cat Pin Grabber Coupler

Undercarriage	Front and Rear Outriggers								
Counterweight	2.8 mt								
Boom Type	1 PC (short)			1 PC			VA		
Stick Length	2.00 m (6'7")	2.30 m (7'7")	2.60 m (8'6")	2.00 m (6'7")	2.30 m (7'7")	2.60 m (8'6")	2.00 m (6'7")	2.30 m (7'7")	2.60 m (8'6")
H110E S	✓	✓	✓	✓	✓	✓	✓	✓	✓
H115 GC	✓	✓	✓	✓	✓	✓	✓	✓	✓
H115 GC S	✓	✓	✓	✓	✓	✓	✓	✓	✓
H115E S	✓	✓	✓	✓	✓	✓	✓	✓	✓

Cat Pin Grabber Coupler (continued)

Undercarriage	Front and Rear Outriggers								
Counterweight	3.3 mt								
Boom Type	1 PC (short)			1 PC			VA		
Stick Length	2.00 m (6'7")	2.30 m (7'7")	2.60 m (8'6")	2.00 m (6'7")	2.30 m (7'7")	2.60 m (8'6")	2.00 m (6'7")	2.30 m (7'7")	2.60 m (8'6")
H110E S	✓	✓	✓	✓	✓	✓	✓	✓	✓
H115 GC	✓	✓	✓	✓	✓	✓	✓	✓	✓
H115 GC S	✓	✓	✓	✓	✓	✓	✓	✓	✓
H115E S	✓	✓	✓	✓	✓	✓	✓	✓	✓

Cat Pin Grabber Coupler (continued)

Undercarriage	Front Blade; Rear Outriggers								
Counterweight	2.8 mt								
Boom Type	1 PC (short)			1 PC			VA		
Stick Length	2.00 m (6'7")	2.30 m (7'7")	2.60 m (8'6")	2.00 m (6'7")	2.30 m (7'7")	2.60 m (8'6")	2.00 m (6'7")	2.30 m (7'7")	2.60 m (8'6")
H110E S	✓	✓	✓	✓	✓	✓	✓	✓	✓
H115 GC	✓	✓	✓	✓	✓	✓	✓	✓	✓
H115 GC S	✓	✓	✓	✓	✓	✓	✓	✓	✓
H115E S	✓	✓	✓	✓	✓	✓	✓	✓	✓

Cat Pin Grabber Coupler (continued)

Undercarriage	Front Blade; Rear Outriggers								
Counterweight	3.3 mt								
Boom Type	1 PC (short)			1 PC			VA		
Stick Length	2.00 m (6'7")	2.30 m (7'7")	2.60 m (8'6")	2.00 m (6'7")	2.30 m (7'7")	2.60 m (8'6")	2.00 m (6'7")	2.30 m (7'7")	2.60 m (8'6")
H110E S	✓	✓	✓	✓	✓	✓	✓	✓	✓
H115 GC	✓	✓	✓	✓	✓	✓	✓	✓	✓
H115 GC S	✓	✓	✓	✓	✓	✓	✓	✓	✓
H115E S	✓	✓	✓	✓	✓	✓	✓	✓	✓

(continued on next page)

Hammer Technical Specifications

Matching – Wheeled Excavators (continued)

Match
 Working Range Front Only
 Allowed Usage on Machine Less Than 50%
 No Match

M314F (continued)

Cat Pin Grabber Coupler (continued)

Undercarriage	Rear Blade							
Counterweight	2.8 mt							
Boom Type	1 PC (short)			1 PC			VA	
Stick Length	2.00 m (6'7")	2.30 m (7'7")	2.60 m (8'6")	2.00 m (6'7")	2.30 m (7'7")	2.60 m (8'6")	2.00 m (6'7")	2.30 m (7'7")
H110E S	✓	✓	✓	✓	✓	✓	✓	✓*
H115 GC	✓	✓*						
H115 GC S	✓	✓	✓*	✓*				
H115E S	✓	✓	✓	✓	✓	✓*	✓*	

Cat Pin Grabber Coupler (continued)

Undercarriage	Rear Blade								
Counterweight	3.3 mt								
Boom Type	1 PC (short)			1 PC			VA		
Stick Length	2.00 m (6'7")	2.30 m (7'7")	2.60 m (8'6")	2.00 m (6'7")	2.30 m (7'7")	2.60 m (8'6")	2.00 m (6'7")	2.30 m (7'7")	2.60 m (8'6")
H110E S	✓	✓	✓	✓	✓	✓	✓	✓	✓
H115 GC	✓	✓	✓	✓	✓*				
H115 GC S	✓	✓	✓	✓	✓	✓*	✓*		
H115E S	✓	✓	✓	✓	✓	✓	✓	✓	✓*

CW-20 S Dedicated Coupler

Undercarriage	Front and Rear Outriggers								
Counterweight	2.8 mt								
Boom Type	1 PC (short)			1 PC			VA		
Stick Length	2.00 m (6'7")	2.30 m (7'7")	2.60 m (8'6")	2.00 m (6'7")	2.30 m (7'7")	2.60 m (8'6")	2.00 m (6'7")	2.30 m (7'7")	2.60 m (8'6")
H110E S	✓	✓	✓	✓	✓	✓	✓	✓	✓
H115 GC S	✓	✓	✓	✓	✓	✓			
H115E S	✓	✓	✓	✓	✓	✓			

CW-20 S Dedicated Coupler (continued)

Undercarriage	Front and Rear Outriggers								
Counterweight	3.3 mt								
Boom Type	1 PC (short)			1 PC			VA		
Stick Length	2.00 m (6'7")	2.30 m (7'7")	2.60 m (8'6")	2.00 m (6'7")	2.30 m (7'7")	2.60 m (8'6")	2.00 m (6'7")	2.30 m (7'7")	2.60 m (8'6")
H110E S	✓	✓	✓	✓	✓	✓	✓	✓	✓
H115 GC S	✓	✓	✓	✓	✓	✓			
H115E S	✓	✓	✓	✓	✓	✓			

CW-20 S Dedicated Coupler (continued)

Undercarriage	Front Blade; Rear Outriggers								
Counterweight	2.8 mt								
Boom Type	1 PC (short)			1 PC			VA		
Stick Length	2.00 m (6'7")	2.30 m (7'7")	2.60 m (8'6")	2.00 m (6'7")	2.30 m (7'7")	2.60 m (8'6")	2.00 m (6'7")	2.30 m (7'7")	2.60 m (8'6")
H110E S	✓	✓	✓	✓	✓	✓	✓	✓	✓
H115 GC S	✓	✓	✓	✓	✓	✓			
H115E S	✓	✓	✓	✓	✓	✓			

(continued on next page)

Matching – Wheeled Excavators *(continued)*

Match
 Working Range Front Only
 Allowed Usage on Machine Less Than 50%
 No Match

M314F *(continued)*

CW-20 S Dedicated Coupler *(continued)*

Undercarriage	Front Blade; Rear Outriggers								
Counterweight	3.3 mt								
Boom Type	1 PC (short)			1 PC			VA		
Stick Length	2.00 m (6'7")	2.30 m (7'7")	2.60 m (8'6")	2.00 m (6'7")	2.30 m (7'7")	2.60 m (8'6")	2.00 m (6'7")	2.30 m (7'7")	2.60 m (8'6")
H110E S	✓	✓	✓	✓	✓	✓	✓	✓	✓
H115 GC S	✓	✓	✓	✓	✓	✓			
H115E S	✓	✓	✓	✓	✓	✓			

CW-20 S Dedicated Coupler *(continued)*

Undercarriage	Rear Blade								
Counterweight	2.8 mt								
Boom Type	1 PC (short)			1 PC			VA		
Stick Length	2.00 m (6'7")	2.30 m (7'7")	2.60 m (8'6")	2.00 m (6'7")	2.30 m (7'7")	2.60 m (8'6")	2.00 m (6'7")	2.30 m (7'7")	2.60 m (8'6")
H110E S	✓	✓	✓	✓	✓	✓	✓	✓	✓*
H115 GC S	✓	✓	✓*	✓*					
H115E S	✓	✓	✓	✓	✓	✓			

CW-20 S Dedicated Coupler *(continued)*

Undercarriage	Rear Blade								
Counterweight	3.3 mt								
Boom Type	1 PC (short)			1 PC			VA		
Stick Length	2.00 m (6'7")	2.30 m (7'7")	2.60 m (8'6")	2.00 m (6'7")	2.30 m (7'7")	2.60 m (8'6")	2.00 m (6'7")	2.30 m (7'7")	2.60 m (8'6")
H110E S	✓	✓	✓	✓	✓	✓	✓	✓	✓
H115 GC S	✓	✓	✓	✓	✓	✓*			
H115E S	✓	✓	✓	✓	✓	✓			

CW-20 Dedicated Coupler

Undercarriage	Front and Rear Outriggers								
Counterweight	2.8 mt								
Boom Type	1 PC (short)			1 PC			VA		
Stick Length	2.00 m (6'7")	2.30 m (7'7")	2.60 m (8'6")	2.00 m (6'7")	2.30 m (7'7")	2.60 m (8'6")	2.00 m (6'7")	2.30 m (7'7")	2.60 m (8'6")
H110E S	✓	✓	✓	✓	✓	✓	✓	✓	✓
H115 GC S	✓	✓	✓	✓	✓	✓			
H115 E S	✓	✓	✓	✓	✓	✓		✓	✓

CW-20 Dedicated Coupler *(continued)*

Undercarriage	Front and Rear Outriggers								
Counterweight	3.3 mt								
Boom Type	1 PC (short)			1 PC			VA		
Stick Length	2.00 m (6'7")	2.30 m (7'7")	2.60 m (8'6")	2.00 m (6'7")	2.30 m (7'7")	2.60 m (8'6")	2.00 m (6'7")	2.30 m (7'7")	2.60 m (8'6")
H110E S	✓	✓	✓	✓	✓	✓	✓	✓	✓
H115 GC S	✓	✓	✓	✓	✓	✓			
H115 E S	✓	✓	✓	✓	✓	✓		✓	✓

(continued on next page)

Hammer Technical Specifications

Matching – Wheeled Excavators (continued)

Match
 * Working Range Front Only
 † Allowed Usage on Machine Less Than 50%
 No Match

M314F (continued)

CW-20 Dedicated Coupler (continued)

Undercarriage	Front Blade; Rear Outriggers								
Counterweight	2.8 mt								
Boom Type	1 PC (short)			1 PC			VA		
Stick Length	2.00 m (6'7")	2.30 m (7'7")	2.60 m (8'6")	2.00 m (6'7")	2.30 m (7'7")	2.60 m (8'6")	2.00 m (6'7")	2.30 m (7'7")	2.60 m (8'6")
H110E S	✓	✓	✓	✓	✓	✓	✓	✓	✓
H115 GC S	✓	✓	✓	✓	✓	✓			
H115 E S	✓	✓	✓	✓	✓	✓		✓	✓

CW-20 Dedicated Coupler (continued)

Undercarriage	Front Blade; Rear Outriggers								
Counterweight	3.3 mt								
Boom Type	1 PC (short)			1 PC			VA		
Stick Length	2.00 m (6'7")	2.30 m (7'7")	2.60 m (8'6")	2.00 m (6'7")	2.30 m (7'7")	2.60 m (8'6")	2.00 m (6'7")	2.30 m (7'7")	2.60 m (8'6")
H110E S	✓	✓	✓	✓	✓	✓	✓	✓	✓
H115 GC S	✓	✓	✓	✓	✓	✓			
H115 E S	✓	✓	✓	✓	✓	✓		✓	✓

CW-20 Dedicated Coupler (continued)

Undercarriage	Rear Blade								
Counterweight	2.8 mt								
Boom Type	1 PC (short)			1 PC			VA		
Stick Length	2.00 m (6'7")	2.30 m (7'7")	2.60 m (8'6")	2.00 m (6'7")	2.30 m (7'7")	2.60 m (8'6")	2.00 m (6'7")	2.30 m (7'7")	2.60 m (8'6")
H110E S	✓	✓	✓	✓	✓	✓	✓	✓	✓*
H115 GC S	✓	✓	✓*	✓	✓*				
H115 E S	✓	✓	✓	✓	✓	✓		✓*	

CW-20 Dedicated Coupler (continued)

Undercarriage	Rear Blade								
Counterweight	3.3 mt								
Boom Type	1 PC (short)			1 PC			VA		
Stick Length	2.00 m (6'7")	2.30 m (7'7")	2.60 m (8'6")	2.00 m (6'7")	2.30 m (7'7")	2.60 m (8'6")	2.00 m (6'7")	2.30 m (7'7")	2.60 m (8'6")
H110E S	✓	✓	✓	✓	✓	✓	✓	✓	✓
H115 GC S	✓	✓	✓	✓	✓	✓			
H115 E S	✓	✓	✓	✓	✓	✓		✓	✓*

M315D2

Pin-on

Undercarriage	Front Outriggers; Rear Blade					
Counterweight	2.9 mt					
Boom Type	1 PC (short)		1 PC		VA	
Stick Length	2.00 m (6'7")	2.30 m (7'7")	2.00 m (6'7")	2.30 m (7'7")	2.00 m (6'7")	2.30 m (7'7")
H110E S	✓	✓	✓	✓	✓	✓
H115 GC	✓	✓	✓	✓	✓	✓
H115 GC S	✓	✓	✓	✓	✓	✓
H115E S	✓	✓	✓	✓	✓	✓

(continued on next page)

Matching – Wheeled Excavators (continued)

Match
 Working Range Front Only
 Allowed Usage on Machine Less Than 50%
 No Match

M315D2 (continued)

Pin-on (continued)

Undercarriage	Front Outriggers; Rear Blade					
Counterweight	3.3 mt					
Boom Type	1 PC (short)		1 PC		VA	
Stick Length	2.00 m (6'7")	2.30 m (7'7")	2.00 m (6'7")	2.30 m (7'7")	2.00 m (6'7")	2.30 m (7'7")
H110E S	✓	✓	✓	✓	✓	✓
H115 GC	✓	✓	✓	✓	✓	✓
H115 GC S	✓	✓	✓	✓	✓	✓
H115E S	✓	✓	✓	✓	✓	✓

Pin-on (continued)

Undercarriage	Rear Blade					
Counterweight	2.9 mt					
Boom Type	1 PC (short)		1 PC		VA	
Stick Length	2.00 m (6'7")	2.30 m (7'7")	2.00 m (6'7")	2.30 m (7'7")	2.00 m (6'7")	2.30 m (7'7")
H110E S	✓	✓	✓	✓	✓	✓
H115 GC	✓	✓	✓	✓	✓	✓
H115 GC S	✓	✓	✓	✓	✓	✓
H115E S	✓	✓	✓	✓	✓	✓

Pin-on (continued)

Undercarriage	Rear Blade					
Counterweight	3.3 mt					
Boom Type	1 PC (short)		1 PC		VA	
Stick Length	2.00 m (6'7")	2.30 m (7'7")	2.00 m (6'7")	2.30 m (7'7")	2.00 m (6'7")	2.30 m (7'7")
H110E S	✓	✓	✓	✓	✓	✓
H115 GC	✓	✓	✓	✓	✓	✓
H115 GC S	✓	✓	✓	✓	✓	✓
H115E S	✓	✓	✓	✓	✓	✓

Cat Pin Grabber Coupler

Undercarriage	Front Outriggers; Rear Blade					
Counterweight	2.9 mt					
Boom Type	1 PC (short)		1 PC		VA	
Stick Length	2.00 m (6'7")	2.30 m (7'7")	2.00 m (6'7")	2.30 m (7'7")	2.00 m (6'7")	2.30 m (7'7")
H110E S	✓	✓	✓	✓	✓	✓
H115 GC	✓	✓	✓	✓	✓	✓
H115 GC S	✓	✓	✓	✓	✓	✓
H115E S	✓	✓	✓	✓	✓	✓

Cat Pin Grabber Coupler (continued)

Undercarriage	Front Outriggers; Rear Blade					
Counterweight	3.3 mt					
Boom Type	1 PC (short)		1 PC		VA	
Stick Length	2.00 m (6'7")	2.30 m (7'7")	2.00 m (6'7")	2.30 m (7'7")	2.00 m (6'7")	2.30 m (7'7")
H110E S	✓	✓	✓	✓	✓	✓
H115 GC	✓	✓	✓	✓	✓	✓
H115 GC S	✓	✓	✓	✓	✓	✓
H115E S	✓	✓	✓	✓	✓	✓

(continued on next page)

Hammer Technical Specifications

Matching – Wheeled Excavators (continued)

Match
 Working Range Front Only
 † Allowed Usage on Machine Less Than 50%
 No Match

M315D2 (continued)

Cat Pin Grabber Coupler (continued)

Undercarriage	Rear Blade					
Counterweight	2.9 mt					
Boom Type	1 PC (short)		1 PC		VA	
Stick Length	2.00 m (6'7")	2.30 m (7'7")	2.00 m (6'7")	2.30 m (7'7")	2.00 m (6'7")	2.30 m (7'7")
H110E S	✓	✓	✓	✓	✓	✓
H115 GC	✓	✓*				
H115 GC S	✓	✓	✓*			
H115E S	✓	✓	✓	✓	✓	✓*

Cat Pin Grabber Coupler (continued)

Undercarriage	Rear Blade					
Counterweight	3.3 mt					
Boom Type	1 PC (short)		1 PC		VA	
Stick Length	2.00 m (6'7")	2.30 m (7'7")	2.00 m (6'7")	2.30 m (7'7")	2.00 m (6'7")	2.30 m (7'7")
H110E S	✓	✓	✓	✓	✓	✓
H115 GC	✓	✓	✓	✓*	✓*	
H115 GC S	✓	✓	✓	✓	✓*	
H115E S	✓	✓	✓	✓	✓	✓

CW-20 S Dedicated Coupler

Undercarriage	Front Outriggers; Rear Blade					
Counterweight	2.9 mt					
Boom Type	1 PC (short)		1 PC		VA	
Stick Length	2.00 m (6'7")	2.30 m (7'7")	2.00 m (6'7")	2.30 m (7'7")	2.00 m (6'7")	2.30 m (7'7")
H110E S	✓	✓	✓	✓	✓	✓
H115 GC	✓	✓	✓	✓		
H115 GC S	✓	✓	✓	✓		
H115E S	✓	✓	✓	✓		

CW-20 S Dedicated Coupler (continued)

Undercarriage	Front Outriggers; Rear Blade					
Counterweight	3.3 mt					
Boom Type	1 PC (short)		1 PC		VA	
Stick Length	2.00 m (6'7")	2.30 m (7'7")	2.00 m (6'7")	2.30 m (7'7")	2.00 m (6'7")	2.30 m (7'7")
H110E S	✓	✓	✓	✓	✓	✓
H115 GC	✓	✓	✓	✓		
H115 GC S	✓	✓	✓	✓		
H115E S	✓	✓	✓	✓		

CW-20 S Dedicated Coupler (continued)

Undercarriage	Rear Blade					
Counterweight	2.9 mt					
Boom Type	1 PC (short)		1 PC		VA	
Stick Length	2.00 m (6'7")	2.30 m (7'7")	2.00 m (6'7")	2.30 m (7'7")	2.00 m (6'7")	2.30 m (7'7")
H110E S	✓	✓	✓	✓	✓	✓
H115 GC	✓	✓*	✓*			
H115 GC S	✓	✓	✓*	✓*		
H115E S	✓	✓	✓	✓		

(continued on next page)

Matching – Wheeled Excavators (continued)

Match
 Working Range Front Only
 † Allowed Usage on Machine Less Than 50%
 No Match

M315D2 (continued)

CW-20 S Dedicated Coupler (continued)

Undercarriage	Rear Blade					
Counterweight	3.3 mt					
Boom Type	1 PC (short)		1 PC		VA	
Stick Length	2.00 m (6'7")	2.30 m (7'7")	2.00 m (6'7")	2.30 m (7'7")	2.00 m (6'7")	2.30 m (7'7")
H110E S	✓	✓	✓	✓	✓	✓
H115 GC	✓	✓	✓	✓*		
H115 GC S	✓	✓	✓	✓		
H115E S	✓	✓	✓	✓		

CW-20 Dedicated Coupler

Undercarriage	Front Outriggers; Rear Blade					
Counterweight	2.9 mt					
Boom Type	1 PC (short)		1 PC		VA	
Stick Length	2.00 m (6'7")	2.30 m (7'7")	2.00 m (6'7")	2.30 m (7'7")	2.00 m (6'7")	2.30 m (7'7")
H110E S	✓	✓	✓	✓	✓	✓
H115 GC	✓	✓	✓	✓		
H115 GC S	✓	✓	✓	✓		
H115E S	✓	✓	✓	✓		✓

CW-20 Dedicated Coupler (continued)

Undercarriage	Front Outriggers; Rear Blade					
Counterweight	3.3 mt					
Boom Type	1 PC (short)		1 PC		VA	
Stick Length	2.00 m (6'7")	2.30 m (7'7")	2.00 m (6'7")	2.30 m (7'7")	2.00 m (6'7")	2.30 m (7'7")
H110E S	✓	✓	✓	✓	✓	✓
H115 GC	✓	✓	✓	✓		
H115 GC S	✓	✓	✓	✓		
H115E S	✓	✓	✓	✓		✓

CW-20 Dedicated Coupler (continued)

Undercarriage	Rear Blade					
Counterweight	2.9 mt					
Boom Type	1 PC (short)		1 PC		VA	
Stick Length	2.00 m (6'7")	2.30 m (7'7")	2.00 m (6'7")	2.30 m (7'7")	2.00 m (6'7")	2.30 m (7'7")
H110E S	✓	✓	✓	✓	✓	✓
H115 GC	✓	✓	✓*			
H115 GC S	✓	✓	✓	✓*		
H115E S	✓	✓	✓	✓		✓*

CW-20 Dedicated Coupler (continued)

Undercarriage	Rear Blade					
Counterweight	3.3 mt					
Boom Type	1 PC (short)		1 PC		VA	
Stick Length	2.00 m (6'7")	2.30 m (7'7")	2.00 m (6'7")	2.30 m (7'7")	2.00 m (6'7")	2.30 m (7'7")
H110E S	✓	✓	✓	✓	✓	✓
H115 GC	✓	✓	✓	✓		
H115 GC S	✓	✓	✓	✓		
H115E S	✓	✓	✓	✓		✓

(continued on next page)

Hammer Technical Specifications

Matching – Wheeled Excavators (continued)

Match
 Working Range Front Only
 Allowed Usage on Machine Less Than 50%
 No Match

M315F

Pin-on

Undercarriage	Front (parallel) Blade; Rear Outriggers				Front Outriggers; Rear (parallel) Blade			
Counterweight	3.75 mt				3.75 mt			
Boom Type	Offset		VA		Offset		VA	
Stick Length	2.30 m (7'7")	2.45 m (8'0")	2.30 m (7'7")	2.45 m (8'0")	2.30 m (7'7")	2.45 m (8'0")	2.30 m (7'7")	2.45 m (8'0")
H110E S	✓	✓	✓	✓	✓	✓	✓	✓
H115 GC	✓	✓	✓	✓	✓	✓	✓	✓
H115 GC S	✓	✓	✓	✓	✓	✓	✓	✓
H115E S	✓	✓	✓	✓	✓	✓	✓	✓

Pin-on (continued)

Undercarriage	Front Outriggers; Rear (radial) Blade				Rear (parallel) Blade			
Counterweight	3.75 mt				3.75 mt			
Boom Type	Offset		VA		Offset		VA	
Stick Length	2.30 m (7'7")	2.45 m (8'0")	2.30 m (7'7")	2.45 m (8'0")	2.30 m (7'7")	2.45 m (8'0")	2.30 m (7'7")	2.45 m (8'0")
H110E S	✓	✓	✓	✓	✓	✓	✓	✓
H115 GC	✓	✓	✓	✓	✓	✓	✓	✓
H115 GC S	✓	✓	✓	✓	✓	✓	✓	✓
H115E S	✓	✓	✓	✓	✓	✓	✓	✓

Pin-on (continued)

Undercarriage	Rear (radial) Blade			
Counterweight	3.75 mt			
Boom Type	Offset		VA	
Stick Length	2.30 m (7'7")	2.45 m (8'0")	2.30 m (7'7")	2.45 m (8'0")
H110E S	✓	✓	✓	✓
H115 GC	✓	✓	✓	✓
H115 GC S	✓	✓	✓	✓
H115E S	✓	✓	✓	✓

Cat Pin Grabber Coupler

Undercarriage	Front (parallel) Blade; Rear Outriggers				Front Outriggers; Rear (parallel) Blade			
Counterweight	3.75 mt				3.75 mt			
Boom Type	Offset		VA		Offset		VA	
Stick Length	2.30 m (7'7")	2.45 m (8'0")	2.30 m (7'7")	2.45 m (8'0")	2.30 m (7'7")	2.45 m (8'0")	2.30 m (7'7")	2.45 m (8'0")
H110E S	✓	✓	✓	✓	✓	✓	✓	✓
H115 GC	✓	✓	✓	✓	✓	✓	✓	✓
H115 GC S	✓	✓	✓	✓	✓	✓	✓	✓
H115E S	✓	✓	✓	✓	✓	✓	✓	✓

Cat Pin Grabber Coupler (continued)

Undercarriage	Front Outriggers; Rear (radial) Blade				Rear (parallel) Blade			
Counterweight	3.75 mt				3.75 mt			
Boom Type	Offset		VA		Offset		VA	
Stick Length	2.30 m (7'7")	2.45 m (8'0")	2.30 m (7'7")	2.45 m (8'0")	2.30 m (7'7")	2.45 m (8'0")	2.30 m (7'7")	2.45 m (8'0")
H110E S	✓	✓	✓	✓	✓	✓	✓	✓
H115 GC	✓	✓	✓	✓			✓*	✓*
H115 GC S	✓	✓	✓	✓			✓	✓*
H115E S	✓	✓	✓	✓	✓	✓*	✓	✓

(continued on next page)

Matching – Wheeled Excavators (continued)

Match
 * Working Range Front Only
 † Allowed Usage on Machine Less Than 50%
 No Match

M315F (continued)

Cat Pin Grabber Coupler (continued)

Undercarriage	Rear (radial) Blade			
Counterweight	3.75 mt			
Boom Type	Offset		VA	
Stick Length	2.30 m (7'7")	2.45 m (8'0")	2.30 m (7'7")	2.45 m (8'0")
H110E S	✓	✓	✓	✓
H115 GC			✓*	
H115 GC S			✓*	✓*
H115E S	✓*	✓*	✓	✓

CW-20 S Dedicated Coupler

Undercarriage	Front (parallel) Blade; Rear Outriggers				Front Outriggers; Rear (parallel) Blade			
Counterweight	3.75 mt				3.75 mt			
Boom Type	Offset		VA		Offset		VA	
Stick Length	2.30 m (7'7")	2.45 m (8'0")	2.30 m (7'7")	2.45 m (8'0")	2.30 m (7'7")	2.45 m (8'0")	2.30 m (7'7")	2.45 m (8'0")
H110E S	✓	✓	✓	✓	✓	✓	✓	✓
H115 GC S		✓		✓		✓		✓
H115E S	✓	✓		✓	✓	✓		✓

CW-20 S Dedicated Coupler (continued)

Undercarriage	Front Outriggers; Rear (radial) Blade				Rear (parallel) Blade			
Counterweight	3.75 mt				3.75 mt			
Boom Type	Offset		VA		Offset		VA	
Stick Length	2.30 m (7'7")	2.45 m (8'0")	2.30 m (7'7")	2.45 m (8'0")	2.30 m (7'7")	2.45 m (8'0")	2.30 m (7'7")	2.45 m (8'0")
H110E S	✓	✓	✓	✓	✓	✓	✓	✓
H115 GC S		✓		✓		✓		✓
H115E S	✓	✓		✓	✓	✓		✓

CW-20 S Dedicated Coupler (continued)

Undercarriage	Rear (radial) Blade			
Counterweight	3.75 mt			
Boom Type	Offset		VA	
Stick Length	2.30 m (7'7")	2.45 m (8'0")	2.30 m (7'7")	2.45 m (8'0")
H110E S	✓	✓	✓	✓
H115 GC S				✓*
H115E S	✓	✓		✓

CW-20 Dedicated Coupler

Undercarriage	Front (parallel) Blade; Rear Outriggers				Front Outriggers; Rear (parallel) Blade			
Counterweight	3.75 mt				3.75 mt			
Boom Type	Offset		VA		Offset		VA	
Stick Length	2.30 m (7'7")	2.45 m (8'0")	2.30 m (7'7")	2.45 m (8'0")	2.30 m (7'7")	2.45 m (8'0")	2.30 m (7'7")	2.45 m (8'0")
H110E S	✓	✓	✓	✓	✓	✓	✓	✓
H115 GC		✓		✓		✓		✓
H115E S	✓	✓	✓	✓	✓	✓	✓	✓

(continued on next page)

Hammer Technical Specifications

Matching – Wheeled Excavators (continued)

Match
 Working Range Front Only
 Allowed Usage on Machine Less Than 50%
 No Match

M315F (continued)

CW-20 Dedicated Coupler (continued)

Undercarriage	Front Outriggers; Rear (radial) Blade				Rear (parallel) Blade			
Counterweight	3.75 mt				3.75 mt			
Boom Type	Offset		VA		Offset		VA	
Stick Length	2.30 m (7'7")	2.45 m (8'0")	2.30 m (7'7")	2.45 m (8'0")	2.30 m (7'7")	2.45 m (8'0")	2.30 m (7'7")	2.45 m (8'0")
H110E S	✓	✓	✓	✓	✓	✓	✓	✓
H115 GC		✓		✓				✓
H115E S	✓	✓	✓	✓	✓	✓	✓	✓

CW-20 Dedicated Coupler (continued)

Undercarriage	Rear (radial) Blade			
Counterweight	3.75 mt			
Boom Type	Offset		VA	
Stick Length	2.30 m (7'7")	2.45 m (8'0")	2.30 m (7'7")	2.45 m (8'0")
H110E S	✓	✓	✓	✓
H115 GC				✓
H115E S	✓	✓	✓	✓

M316F

Pin-on

Undercarriage	Front (parallel) Blade; Rear Outriggers					
Counterweight	3.2 mt					
Boom Type	1 PC			VA		
Stick Length	2.10 m (6'11")	2.40 m (7'10")	2.60 m (8'6")	2.10 m (6'11")	2.40 m (7'10")	2.60 m (8'6")
H110E S	✓	✓	✓	✓	✓	✓
H115 GC	✓	✓	✓	✓	✓	✓
H115 GC S	✓	✓	✓	✓	✓	✓
H115E S	✓	✓	✓	✓	✓	✓
H120E S	✓	✓	✓	✓	✓	✓

Pin-on (continued)

Undercarriage	Front (parallel) Blade; Rear Outriggers					
Counterweight	3.7 mt					
Boom Type	1 PC			VA		
Stick Length	2.10 m (6'11")	2.40 m (7'10")	2.60 m (8'6")	2.10 m (6'11")	2.40 m (7'10")	2.60 m (8'6")
H110E S	✓	✓	✓	✓	✓	✓
H115 GC	✓	✓	✓	✓	✓	✓
H115 GC S	✓	✓	✓	✓	✓	✓
H115E S	✓	✓	✓	✓	✓	✓
H120E S	✓	✓	✓	✓	✓	✓

(continued on next page)

Hammer Technical Specifications

Matching – Wheeled Excavators (continued)

Match
 Working Range Front Only
 Allowed Usage on Machine Less Than 50%
 No Match

M316F (continued)

Pin-on (continued)

Undercarriage	Front and Rear Outriggers					
Counterweight	3.2 mt					
Boom Type	1 PC			VA		
Stick Length	2.10 m (6'11")	2.40 m (7'10")	2.60 m (8'6")	2.10 m (6'11")	2.40 m (7'10")	2.60 m (8'6")
H110E S	✓	✓	✓	✓	✓	✓
H115 GC	✓	✓	✓	✓	✓	✓
H115 GC S	✓	✓	✓	✓	✓	✓
H115E S	✓	✓	✓	✓	✓	✓
H120E S	✓	✓	✓	✓	✓	✓

Pin-on (continued)

Undercarriage	Front and Rear Outriggers					
Counterweight	3.7 mt					
Boom Type	1 PC			VA		
Stick Length	2.10 m (6'11")	2.40 m (7'10")	2.60 m (8'6")	2.10 m (6'11")	2.40 m (7'10")	2.60 m (8'6")
H110E S	✓	✓	✓	✓	✓	✓
H115 GC	✓	✓	✓	✓	✓	✓
H115 GC S	✓	✓	✓	✓	✓	✓
H115E S	✓	✓	✓	✓	✓	✓
H120E S	✓	✓	✓	✓	✓	✓

Pin-on (continued)

Undercarriage	Front Blade; Rear Outriggers					
Counterweight	3.2 mt					
Boom Type	1 PC			VA		
Stick Length	2.10 m (6'11")	2.40 m (7'10")	2.60 m (8'6")	2.10 m (6'11")	2.40 m (7'10")	2.60 m (8'6")
H110E S	✓	✓	✓	✓	✓	✓
H115 GC	✓	✓	✓	✓	✓	✓
H115 GC S	✓	✓	✓	✓	✓	✓
H115E S	✓	✓	✓	✓	✓	✓
H120E S	✓	✓	✓	✓	✓	✓

Pin-on (continued)

Undercarriage	Front Blade; Rear Outriggers					
Counterweight	3.7 mt					
Boom Type	1 PC			VA		
Stick Length	2.10 m (6'11")	2.40 m (7'10")	2.60 m (8'6")	2.10 m (6'11")	2.40 m (7'10")	2.60 m (8'6")
H110E S	✓	✓	✓	✓	✓	✓
H115 GC	✓	✓	✓	✓	✓	✓
H115 GC S	✓	✓	✓	✓	✓	✓
H115E S	✓	✓	✓	✓	✓	✓
H120E S	✓	✓	✓	✓	✓	✓

(continued on next page)

Hammer Technical Specifications

Matching – Wheeled Excavators (continued)

Match
 * Working Range Front Only
 † Allowed Usage on Machine Less Than 50%
 No Match

M316F (continued)

Pin-on (continued)

Undercarriage	Rear (parallel) Blade					
Counterweight	3.2 mt					
Boom Type	1 PC			VA		
Stick Length	2.10 m (6'11")	2.40 m (7'10")	2.60 m (8'6")	2.10 m (6'11")	2.40 m (7'10")	2.60 m (8'6")
H110E S	✓	✓	✓	✓	✓	✓
H115 GC	✓	✓	✓	✓	✓	✓
H115 GC S	✓	✓	✓	✓	✓	✓
H115E S	✓	✓	✓	✓	✓	✓
H120E S	✓	✓	✓*	✓*		

Pin-on (continued)

Undercarriage	Rear (parallel) Blade					
Counterweight	3.7 mt					
Boom Type	1 PC			VA		
Stick Length	2.10 m (6'11")	2.40 m (7'10")	2.60 m (8'6")	2.10 m (6'11")	2.40 m (7'10")	2.60 m (8'6")
H110E S	✓	✓	✓	✓	✓	✓
H115 GC	✓	✓	✓	✓	✓	✓
H115 GC S	✓	✓	✓	✓	✓	✓
H115E S	✓	✓	✓	✓	✓	✓
H120E S	✓	✓	✓	✓	✓	✓*

Pin-on (continued)

Undercarriage	Rear Blade					
Counterweight	3.2 mt					
Boom Type	1 PC			VA		
Stick Length	2.10 m (6'11")	2.40 m (7'10")	2.60 m (8'6")	2.10 m (6'11")	2.40 m (7'10")	2.60 m (8'6")
H110E S	✓	✓	✓	✓	✓	✓
H115 GC	✓	✓	✓	✓	✓	✓
H115 GC S	✓	✓	✓	✓	✓	✓
H115E S	✓	✓	✓	✓	✓	✓
H120E S	✓	✓	✓*	✓*		

Pin-on (continued)

Undercarriage	Rear Blade					
Counterweight	3.7 mt					
Boom Type	1 PC			VA		
Stick Length	2.10 m (6'11")	2.40 m (7'10")	2.60 m (8'6")	2.10 m (6'11")	2.40 m (7'10")	2.60 m (8'6")
H110E S	✓	✓	✓	✓	✓	✓
H115 GC	✓	✓	✓	✓	✓	✓
H115 GC S	✓	✓	✓	✓	✓	✓
H115E S	✓	✓	✓	✓	✓	✓
H120E S	✓	✓	✓	✓	✓	✓*

(continued on next page)

Matching – Wheeled Excavators *(continued)*

Match
 * Working Range Front Only
 † Allowed Usage on Machine Less Than 50%
 No Match

M316F *(continued)*

Cat Pin Grabber Coupler

Undercarriage	Front (parallel) Blade; Rear Outriggers					
Counterweight	3.2 mt					
Boom Type	1 PC			VA		
Stick Length	2.10 m (6'11")	2.40 m (7'10")	2.60 m (8'6")	2.10 m (6'11")	2.40 m (7'10")	2.60 m (8'6")
H110E S	✓	✓	✓	✓	✓	✓
H115 GC	✓	✓	✓	✓	✓	✓
H115 GC S	✓	✓	✓	✓	✓	✓
H115E S	✓	✓	✓	✓	✓	✓
H120E S	✓	✓	✓	✓	✓	✓

Cat Pin Grabber Coupler *(continued)*

Undercarriage	Front (parallel) Blade; Rear Outriggers					
Counterweight	3.7 mt					
Boom Type	1 PC			VA		
Stick Length	2.10 m (6'11")	2.40 m (7'10")	2.60 m (8'6")	2.10 m (6'11")	2.40 m (7'10")	2.60 m (8'6")
H110E S	✓	✓	✓	✓	✓	✓
H115 GC	✓	✓	✓	✓	✓	✓
H115 GC S	✓	✓	✓	✓	✓	✓
H115E S	✓	✓	✓	✓	✓	✓
H120E S	✓	✓	✓	✓	✓	✓

Cat Pin Grabber Coupler *(continued)*

Undercarriage	Front and Rear Outriggers					
Counterweight	3.2 mt					
Boom Type	1 PC			VA		
Stick Length	2.10 m (6'11")	2.40 m (7'10")	2.60 m (8'6")	2.10 m (6'11")	2.40 m (7'10")	2.60 m (8'6")
H110E S	✓	✓	✓	✓	✓	✓
H115 GC	✓	✓	✓	✓	✓	✓
H115 GC S	✓	✓	✓	✓	✓	✓
H115E S	✓	✓	✓	✓	✓	✓
H120E S	✓	✓	✓	✓	✓	✓

Cat Pin Grabber Coupler *(continued)*

Undercarriage	Front and Rear Outriggers					
Counterweight	3.7 mt					
Boom Type	1 PC			VA		
Stick Length	2.10 m (6'11")	2.40 m (7'10")	2.60 m (8'6")	2.10 m (6'11")	2.40 m (7'10")	2.60 m (8'6")
H110E S	✓	✓	✓	✓	✓	✓
H115 GC	✓	✓	✓	✓	✓	✓
H115 GC S	✓	✓	✓	✓	✓	✓
H115E S	✓	✓	✓	✓	✓	✓
H120E S	✓	✓	✓	✓	✓	✓

(continued on next page)

Hammer Technical Specifications

Matching – Wheeled Excavators (continued)

Match
 Working Range Front Only
 Allowed Usage on Machine Less Than 50%
 No Match

M316F (continued)

Cat Pin Grabber Coupler (continued)

Undercarriage	Front Blade; Rear Outriggers					
Counterweight	3.2 mt					
Boom Type	1 PC			VA		
Stick Length	2.10 m (6'11")	2.40 m (7'10")	2.60 m (8'6")	2.10 m (6'11")	2.40 m (7'10")	2.60 m (8'6")
H110E S	✓	✓	✓	✓	✓	✓
H115 GC	✓	✓	✓	✓	✓	✓
H115 GC S	✓	✓	✓	✓	✓	✓
H115E S	✓	✓	✓	✓	✓	✓
H120E S	✓	✓	✓	✓	✓	✓

Cat Pin Grabber Coupler (continued)

Undercarriage	Front Blade; Rear Outriggers					
Counterweight	3.7 mt					
Boom Type	1 PC			VA		
Stick Length	2.10 m (6'11")	2.40 m (7'10")	2.60 m (8'6")	2.10 m (6'11")	2.40 m (7'10")	2.60 m (8'6")
H110E S	✓	✓	✓	✓	✓	✓
H115 GC	✓	✓	✓	✓	✓	✓
H115 GC S	✓	✓	✓	✓	✓	✓
H115E S	✓	✓	✓	✓	✓	✓
H120E S	✓	✓	✓	✓	✓	✓

Cat Pin Grabber Coupler (continued)

Undercarriage	Rear (parallel) Blade					
Counterweight	3.2 mt					
Boom Type	1 PC			VA		
Stick Length	2.10 m (6'11")	2.40 m (7'10")	2.60 m (8'6")	2.10 m (6'11")	2.40 m (7'10")	2.60 m (8'6")
H110E S	✓	✓	✓	✓	✓	✓
H115 GC	✓	✓*				
H115 GC S	✓	✓*	✓*	✓*		
H115E S	✓	✓	✓	✓	✓	✓*
H120E S						

Cat Pin Grabber Coupler (continued)

Undercarriage	Rear (parallel) Blade					
Counterweight	3.7 mt					
Boom Type	1 PC			VA		
Stick Length	2.10 m (6'11")	2.40 m (7'10")	2.60 m (8'6")	2.10 m (6'11")	2.40 m (7'10")	2.60 m (8'6")
H110E S	✓	✓	✓	✓	✓	✓
H115 GC	✓	✓	✓	✓	✓*	
H115 GC S	✓	✓	✓	✓	✓	✓*
H115E S	✓	✓	✓	✓	✓	✓
H120E S	✓*					

(continued on next page)

Hammer Technical Specifications

Matching – Wheeled Excavators *(continued)*

Match
 * Working Range Front Only
 † Allowed Usage on Machine Less Than 50%
 No Match

M316F *(continued)*

Cat Pin Grabber Coupler *(continued)*

Undercarriage	Rear Blade					
Counterweight	3.2 mt					
Boom Type	1 PC			VA		
Stick Length	2.10 m (6'11")	2.40 m (7'10")	2.60 m (8'6")	2.10 m (6'11")	2.40 m (7'10")	2.60 m (8'6")
H110E S	✓	✓	✓	✓	✓	✓
H115 GC	✓*					
H115 GC S	✓	✓*	✓*	✓*		
H115E S	✓	✓	✓	✓	✓*	✓*
H120E S						

Cat Pin Grabber Coupler *(continued)*

Undercarriage	Rear Blade					
Counterweight	3.7 mt					
Boom Type	1 PC			VA		
Stick Length	2.10 m (6'11")	2.40 m (7'10")	2.60 m (8'6")	2.10 m (6'11")	2.40 m (7'10")	2.60 m (8'6")
H110E S	✓	✓	✓	✓	✓	✓
H115 GC	✓	✓	✓*	✓*	✓*	
H115 GC S	✓	✓	✓	✓	✓*	✓*
H115E S	✓	✓	✓	✓	✓	✓
H120E S	✓*					

CW-20 S Dedicated Coupler

Undercarriage	Front (parallel) Blade; Rear Outriggers					
Counterweight	3.2 mt					
Boom Type	1 PC			VA		
Stick Length	2.10 m (6'11")	2.40 m (7'10")	2.60 m (8'6")	2.10 m (6'11")	2.40 m (7'10")	2.60 m (8'6")
H110E S	✓	✓	✓	✓	✓	✓
H115 GC S	✓	✓	✓	✓	✓	✓
H115E S	✓	✓	✓	✓	✓	✓
H120E S	✓	✓	✓			

CW-20 S Dedicated Coupler *(continued)*

Undercarriage	Front (parallel) Blade; Rear Outriggers					
Counterweight	3.7 mt					
Boom Type	1 PC			VA		
Stick Length	2.10 m (6'11")	2.40 m (7'10")	2.60 m (8'6")	2.10 m (6'11")	2.40 m (7'10")	2.60 m (8'6")
H110E S	✓	✓	✓	✓	✓	✓
H115 GC S	✓	✓	✓	✓	✓	✓
H115E S	✓	✓	✓	✓	✓	✓
H120E S	✓	✓	✓			

(continued on next page)

Hammer Technical Specifications

Matching – Wheeled Excavators (continued)

Match
 Working Range Front Only
 Allowed Usage on Machine Less Than 50%
 No Match

M316F (continued)

CW-20 S Dedicated Coupler (continued)

Undercarriage	Front and Rear Outriggers					
Counterweight	3.2 mt					
Boom Type	1 PC			VA		
Stick Length	2.10 m (6'11")	2.40 m (7'10")	2.60 m (8'6")	2.10 m (6'11")	2.40 m (7'10")	2.60 m (8'6")
H110E S	✓	✓	✓	✓	✓	✓
H115 GC S	✓	✓	✓	✓	✓	✓
H115E S	✓	✓	✓	✓	✓	✓
H120E S	✓	✓	✓			

CW-20 S Dedicated Coupler (continued)

Undercarriage	Front and Rear Outriggers					
Counterweight	3.7 mt					
Boom Type	1 PC			VA		
Stick Length	2.10 m (6'11")	2.40 m (7'10")	2.60 m (8'6")	2.10 m (6'11")	2.40 m (7'10")	2.60 m (8'6")
H110E S	✓	✓	✓	✓	✓	✓
H115 GC S	✓	✓	✓	✓	✓	✓
H115E S	✓	✓	✓	✓	✓	✓
H120E S	✓	✓	✓			

CW-20 S Dedicated Coupler (continued)

Undercarriage	Front Blade; Rear Outriggers					
Counterweight	3.2 mt					
Boom Type	1 PC			VA		
Stick Length	2.10 m (6'11")	2.40 m (7'10")	2.60 m (8'6")	2.10 m (6'11")	2.40 m (7'10")	2.60 m (8'6")
H110E S	✓	✓	✓	✓	✓	✓
H115 GC S	✓	✓	✓	✓	✓	✓
H115E S	✓	✓	✓	✓	✓	✓
H120E S	✓	✓	✓			

CW-20 S Dedicated Coupler (continued)

Undercarriage	Front Blade; Rear Outriggers					
Counterweight	3.7 mt					
Boom Type	1 PC			VA		
Stick Length	2.10 m (6'11")	2.40 m (7'10")	2.60 m (8'6")	2.10 m (6'11")	2.40 m (7'10")	2.60 m (8'6")
H110E S	✓	✓	✓	✓	✓	✓
H115 GC S	✓	✓	✓	✓	✓	✓
H115E S	✓	✓	✓	✓	✓	✓
H120E S	✓	✓	✓			

CW-20 S Dedicated Coupler (continued)

Undercarriage	Rear (parallel) Blade					
Counterweight	3.2 mt					
Boom Type	1 PC			VA		
Stick Length	2.10 m (6'11")	2.40 m (7'10")	2.60 m (8'6")	2.10 m (6'11")	2.40 m (7'10")	2.60 m (8'6")
H110E S	✓	✓	✓	✓	✓	✓
H115 GC S	✓	✓	✓*	✓*		
H115E S	✓	✓	✓	✓	✓	✓
H120E S						

(continued on next page)

Matching – Wheeled Excavators (continued)

Match
 Working Range Front Only
 † Allowed Usage on Machine Less Than 50%
 No Match

M316F (continued)

CW-20 S Dedicated Coupler (continued)

Undercarriage	Rear (parallel) Blade					
Counterweight	3.7 mt					
Boom Type	1 PC			VA		
Stick Length	2.10 m (6'11")	2.40 m (7'10")	2.60 m (8'6")	2.10 m (6'11")	2.40 m (7'10")	2.60 m (8'6")
H110E S	✓	✓	✓	✓	✓	✓
H115 GC S	✓	✓	✓	✓	✓	✓*
H115E S	✓	✓	✓	✓	✓	✓
H120E S	✓	✓*				

CW-20 S Dedicated Coupler (continued)

Undercarriage	Rear Blade					
Counterweight	3.2 mt					
Boom Type	1 PC			VA		
Stick Length	2.10 m (6'11")	2.40 m (7'10")	2.60 m (8'6")	2.10 m (6'11")	2.40 m (7'10")	2.60 m (8'6")
H110E S	✓	✓	✓	✓	✓	✓
H115 GC S	✓	✓*	✓*	✓*		
H115E S	✓	✓	✓	✓	✓	✓
H120E S						

CW-20 S Dedicated Coupler (continued)

Undercarriage	Rear Blade					
Counterweight	3.7 mt					
Boom Type	1 PC			VA		
Stick Length	2.10 m (6'11")	2.40 m (7'10")	2.60 m (8'6")	2.10 m (6'11")	2.40 m (7'10")	2.60 m (8'6")
H110E S	✓	✓	✓	✓	✓	✓
H115 GC S	✓	✓	✓	✓	✓*	✓*
H115E S	✓	✓	✓	✓	✓	✓
H120E S	✓	✓*				

CW-20 Dedicated Coupler

Undercarriage	Front (parallel) Blade; Rear Outriggers					
Counterweight	3.2 mt					
Boom Type	1 PC			VA		
Stick Length	2.10 m (6'11")	2.40 m (7'10")	2.60 m (8'6")	2.10 m (6'11")	2.40 m (7'10")	2.60 m (8'6")
H110E S	✓	✓	✓	✓	✓	✓
H115 GC	✓	✓	✓	✓	✓	✓
H115E S	✓	✓	✓	✓	✓	✓
H120E S	✓	✓	✓			

CW-20 Dedicated Coupler (continued)

Undercarriage	Front (parallel) Blade; Rear Outriggers					
Counterweight	3.7 mt					
Boom Type	1 PC			VA		
Stick Length	2.10 m (6'11")	2.40 m (7'10")	2.60 m (8'6")	2.10 m (6'11")	2.40 m (7'10")	2.60 m (8'6")
H110E S	✓	✓	✓	✓	✓	✓
H115 GC	✓	✓	✓	✓	✓	✓
H115E S	✓	✓	✓	✓	✓	✓
H120E S	✓	✓	✓			

(continued on next page)

Hammer Technical Specifications

Matching – Wheeled Excavators (continued)

Match
 Working Range Front Only
 Allowed Usage on Machine Less Than 50%
 No Match

M316F (continued)

CW-20 Dedicated Coupler (continued)

Undercarriage	Front and Rear Outriggers					
Counterweight	3.2 mt					
Boom Type	1 PC			VA		
Stick Length	2.10 m (6'11")	2.40 m (7'10")	2.60 m (8'6")	2.10 m (6'11")	2.40 m (7'10")	2.60 m (8'6")
H110E S	✓	✓	✓	✓	✓	✓
H115 GC	✓	✓	✓	✓	✓	✓
H115E S	✓	✓	✓	✓	✓	✓
H120E S	✓	✓	✓			

CW-20 Dedicated Coupler (continued)

Undercarriage	Front and Rear Outriggers					
Counterweight	3.7 mt					
Boom Type	1 PC			VA		
Stick Length	2.10 m (6'11")	2.40 m (7'10")	2.60 m (8'6")	2.10 m (6'11")	2.40 m (7'10")	2.60 m (8'6")
H110E S	✓	✓	✓	✓	✓	✓
H115 GC	✓	✓	✓	✓	✓	✓
H115E S	✓	✓	✓	✓	✓	✓
H120E S	✓	✓	✓			

CW-20 Dedicated Coupler (continued)

Undercarriage	Front Blade; Rear Outriggers					
Counterweight	3.2 mt					
Boom Type	1 PC			VA		
Stick Length	2.10 m (6'11")	2.40 m (7'10")	2.60 m (8'6")	2.10 m (6'11")	2.40 m (7'10")	2.60 m (8'6")
H110E S	✓	✓	✓	✓	✓	✓
H115 GC	✓	✓	✓	✓	✓	✓
H115E S	✓	✓	✓	✓	✓	✓
H120E S	✓	✓	✓			

CW-20 Dedicated Coupler (continued)

Undercarriage	Front Blade; Rear Outriggers					
Counterweight	3.7 mt					
Boom Type	1 PC			VA		
Stick Length	2.10 m (6'11")	2.40 m (7'10")	2.60 m (8'6")	2.10 m (6'11")	2.40 m (7'10")	2.60 m (8'6")
H110E S	✓	✓	✓	✓	✓	✓
H115 GC	✓	✓	✓	✓	✓	✓
H115E S	✓	✓	✓	✓	✓	✓
H120E S	✓	✓	✓			

CW-20 Dedicated Coupler (continued)

Undercarriage	Rear (parallel) Blade					
Counterweight	3.2 mt					
Boom Type	1 PC			VA		
Stick Length	2.10 m (6'11")	2.40 m (7'10")	2.60 m (8'6")	2.10 m (6'11")	2.40 m (7'10")	2.60 m (8'6")
H110E S	✓	✓	✓	✓	✓	✓
H115 GC	✓	✓	✓*	✓*	✓*	
H115E S	✓	✓	✓	✓	✓	✓
H120E S						

(continued on next page)

Matching – Wheeled Excavators *(continued)*

Match
 * Working Range Front Only
 † Allowed Usage on Machine Less Than 50%
 No Match

M316F *(continued)*

CW-20 Dedicated Coupler *(continued)*

Undercarriage	Rear (parallel) Blade					
Counterweight	3.7 mt					
Boom Type	1 PC			VA		
Stick Length	2.10 m (6'11")	2.40 m (7'10")	2.60 m (8'6")	2.10 m (6'11")	2.40 m (7'10")	2.60 m (8'6")
H110E S	✓	✓	✓	✓	✓	✓
H115 GC	✓	✓	✓	✓	✓	✓
H115E S	✓	✓	✓	✓	✓	✓
H120E S	✓	✓*				

CW-20 Dedicated Coupler *(continued)*

Undercarriage	Rear Blade					
Counterweight	3.2 mt					
Boom Type	1 PC			VA		
Stick Length	2.10 m (6'11")	2.40 m (7'10")	2.60 m (8'6")	2.10 m (6'11")	2.40 m (7'10")	2.60 m (8'6")
H110E S	✓	✓	✓	✓	✓	✓
H115 GC	✓	✓	✓*	✓*		
H115E S	✓	✓	✓	✓	✓	✓*
H120E S						

CW-20 Dedicated Coupler *(continued)*

Undercarriage	Rear Blade					
Counterweight	3.7 mt					
Boom Type	1 PC			VA		
Stick Length	2.10 m (6'11")	2.40 m (7'10")	2.60 m (8'6")	2.10 m (6'11")	2.40 m (7'10")	2.60 m (8'6")
H110E S	✓	✓	✓	✓	✓	✓
H115 GC	✓	✓	✓	✓	✓	✓*
H115E S	✓	✓	✓	✓	✓	✓
H120E S	✓	✓*				

M317D2

Pin-on

Undercarriage	Front Outriggers; Rear Blade							
Counterweight	3.5 mt				3.9 mt			
Boom Type	1 PC		VA		1 PC		VA	
Stick Length	2.40 m (7'10")	2.60 m (8'6")	2.40 m (7'10")	2.60 m (8'6")	2.40 m (7'10")	2.60 m (8'6")	2.40 m (7'10")	2.60 m (8'6")
H110E S	✓	✓	✓	✓	✓	✓	✓	✓
H115 GC	✓	✓	✓	✓	✓	✓	✓	✓
H115 GC S	✓	✓	✓	✓	✓	✓	✓	✓
H115E S	✓	✓	✓	✓	✓	✓	✓	✓
H120E S	✓	✓	✓	✓	✓	✓	✓	✓

(continued on next page)

Hammer Technical Specifications

Matching – Wheeled Excavators *(continued)*

Match
 Working Range Front Only
 Allowed Usage on Machine Less Than 50%
 No Match

M317D2 *(continued)*

Pin-on *(continued)*

Undercarriage	Rear Blade							
	3.5 mt				3.9 mt			
	1 PC		VA		1 PC		VA	
Stick Length	2.40 m (7'10")	2.60 m (8'6")	2.40 m (7'10")	2.60 m (8'6")	2.40 m (7'10")	2.60 m (8'6")	2.40 m (7'10")	2.60 m (8'6")
H110E S	✓	✓	✓	✓	✓	✓	✓	✓
H115 GC	✓	✓	✓	✓	✓	✓	✓	✓
H115 GC S	✓	✓	✓	✓	✓	✓	✓	✓
H115E S	✓	✓	✓	✓	✓	✓	✓	✓
H120E S	✓	✓*	✓*		✓	✓	✓	✓

Cat Pin Grabber Coupler

Undercarriage	Front Outriggers; Rear Blade							
	3.5 mt				3.9 mt			
	1 PC		VA		1 PC		VA	
Stick Length	2.40 m (7'10")	2.60 m (8'6")	2.40 m (7'10")	2.60 m (8'6")	2.40 m (7'10")	2.60 m (8'6")	2.40 m (7'10")	2.60 m (8'6")
H110E S	✓	✓	✓	✓	✓	✓	✓	✓
H115 GC	✓	✓	✓	✓	✓	✓	✓	✓
H115 GC S	✓	✓	✓	✓	✓	✓	✓	✓
H115E S	✓	✓	✓	✓	✓	✓	✓	✓
H120E S	✓	✓	✓	✓	✓	✓	✓	✓

Cat Pin Grabber Coupler *(continued)*

Undercarriage	Rear Blade							
	3.5 mt				3.9 mt			
	1 PC		VA		1 PC		VA	
Stick Length	2.40 m (7'10")	2.60 m (8'6")	2.40 m (7'10")	2.60 m (8'6")	2.40 m (7'10")	2.60 m (8'6")	2.40 m (7'10")	2.60 m (8'6")
H110E S	✓	✓	✓	✓	✓	✓	✓	✓
H115 GC	✓*				✓	✓	✓*	✓*
H115 GC S	✓	✓*	✓*		✓	✓	✓	✓*
H115E S	✓	✓	✓	✓	✓	✓	✓	✓
H120E S								

CW-20 S Dedicated Coupler

Undercarriage	Front Outriggers; Rear Blade							
	3.5 mt				3.9 mt			
	1 PC		VA		1 PC		VA	
Stick Length	2.40 m (7'10")	2.60 m (8'6")	2.40 m (7'10")	2.60 m (8'6")	2.40 m (7'10")	2.60 m (8'6")	2.40 m (7'10")	2.60 m (8'6")
H110E S	✓	✓	✓	✓	✓	✓	✓	✓
H115 GC	✓	✓	✓	✓	✓	✓	✓	✓
H115 GC S	✓	✓	✓	✓	✓	✓	✓	✓
H115E S	✓	✓	✓	✓	✓	✓	✓	✓
H120E S	✓	✓			✓	✓		

(continued on next page)

Hammer Technical Specifications

Matching – Wheeled Excavators (continued)

Match
 * Working Range Front Only
 † Allowed Usage on Machine Less Than 50%
 No Match

M317D2 (continued)

CW-20 S Dedicated Coupler (continued)

Undercarriage	Rear Blade							
	3.5 mt				3.9 mt			
Counterweight	1 PC		VA		1 PC		VA	
Stick Length	2.40 m (7'10")	2.60 m (8'6")	2.40 m (7'10")	2.60 m (8'6")	2.40 m (7'10")	2.60 m (8'6")	2.40 m (7'10")	2.60 m (8'6")
H110E S	✓	✓	✓	✓	✓	✓	✓	✓
H115 GC	✓*	✓*			✓	✓	✓*	✓*
H115 GC S	✓	✓*	✓*		✓	✓	✓	✓*
H115E S	✓	✓	✓	✓	✓	✓	✓	✓
H120E S					✓*			

CW-20 Dedicated Coupler

Undercarriage	Front Outriggers; Rear Blade							
	3.5 mt				3.9 mt			
Counterweight	1 PC		VA		1 PC		VA	
Stick Length	2.40 m (7'10")	2.60 m (8'6")	2.40 m (7'10")	2.60 m (8'6")	2.40 m (7'10")	2.60 m (8'6")	2.40 m (7'10")	2.60 m (8'6")
H110E S	✓	✓	✓	✓	✓	✓	✓	✓
H115 GC	✓	✓	✓	✓	✓	✓	✓	✓
H115 GC S	✓	✓	✓	✓	✓	✓	✓	✓
H115E S	✓	✓	✓	✓	✓	✓	✓	✓
H120E S	✓	✓			✓	✓		

CW-20 Dedicated Coupler (continued)

Undercarriage	Rear Blade							
	3.5 mt				3.9 mt			
Counterweight	1 PC		VA		1 PC		VA	
Stick Length	2.40 m (7'10")	2.60 m (8'6")	2.40 m (7'10")	2.60 m (8'6")	2.40 m (7'10")	2.60 m (8'6")	2.40 m (7'10")	2.60 m (8'6")
H110E S	✓	✓	✓	✓	✓	✓	✓	✓
H115 GC	✓	✓*			✓	✓	✓	✓*
H115 GC S	✓	✓	✓*	✓*	✓	✓	✓	✓
H115E S	✓	✓	✓	✓	✓	✓	✓	✓
H120E S					✓*			

M317F

Pin-on

Undercarriage	Front (parallel) Blade; Rear Outriggers				Front Outriggers; Rear (parallel) Blade		
	4.3 mt						
Counterweight	Offset		VA		Offset		VA
Stick Length	2.45 m (8'0")	2.45 m (8'0")	2.60 m (8'6")	2.45 m (8'0")	2.45 m (8'0")	2.60 m (8'6")	
H110E S	✓	✓	✓	✓	✓	✓	
H115 GC	✓	✓	✓	✓	✓	✓	
H115 GC S	✓	✓	✓	✓	✓	✓	
H115E S	✓	✓	✓	✓	✓	✓	
H120E S	✓	✓			✓	✓	

(continued on next page)

Hammer Technical Specifications

Matching – Wheeled Excavators (continued)

Match
 Working Range Front Only
 Allowed Usage on Machine Less Than 50%
 No Match

M317F (continued)

Pin-on (continued)

Undercarriage	Rear (parallel) Blade			Wide Axle – Rear (parallel) Blade		
Counterweight	4.3 mt			4.3 mt		
Boom Type	Offset	VA		Offset	VA	
Stick Length	2.45 m (8'0")	2.45 m (8'0")	2.60 m (8'6")	2.45 m (8'0")	2.45 m (8'0")	2.60 m (8'6")
H110E S	✓	✓	✓	✓	✓	✓
H115 GC	✓	✓	✓	✓	✓	✓
H115 GC S	✓	✓	✓	✓	✓	✓
H115E S	✓	✓	✓	✓	✓	✓
H120E S	✓	✓		✓	✓	

Cat Pin Grabber Coupler

Undercarriage	Front (parallel) Blade; Rear Outriggers			Front Outriggers; Rear (parallel) Blade		
Counterweight	4.3 mt			4.3 mt		
Boom Type	Offset	VA		Offset	VA	
Stick Length	2.45 m (8'0")	2.45 m (8'0")	2.60 m (8'6")	2.45 m (8'0")	2.45 m (8'0")	2.60 m (8'6")
H110E S	✓	✓	✓	✓	✓	✓
H115 GC	✓	✓	✓	✓	✓	✓
H115 GC S	✓	✓	✓	✓	✓	✓
H115E S	✓	✓	✓	✓	✓	✓

Cat Pin Grabber Coupler (continued)

Undercarriage	Rear (parallel) Blade			Wide Axle – Rear (parallel) Blade		
Counterweight	4.3 mt			4.3 mt		
Boom Type	Offset	VA		Offset	VA	
Stick Length	2.45 m (8'0")	2.45 m (8'0")	2.60 m (8'6")	2.45 m (8'0")	2.45 m (8'0")	2.60 m (8'6")
H110E S	✓	✓	✓	✓	✓	✓
H115 GC	✓*	✓	✓*	✓	✓	✓
H115 GC S	✓*	✓	✓	✓	✓	✓
H115E S	✓	✓	✓	✓	✓	✓

CW-20 S Dedicated Coupler

Undercarriage	Front (parallel) Blade; Rear Outriggers			Front Outriggers; Rear (parallel) Blade		
Counterweight	4.3 mt			4.3 mt		
Boom Type	Offset	VA		Offset	VA	
Stick Length	2.45 m (8'0")	2.45 m (8'0")	2.60 m (8'6")	2.45 m (8'0")	2.45 m (8'0")	2.60 m (8'6")
H110E S	✓	✓	✓	✓	✓	✓
H115 GC S	✓	✓		✓	✓	
H115E S	✓	✓	✓	✓	✓	✓

CW-20 S Dedicated Coupler (continued)

Undercarriage	Rear (parallel) Blade			Wide Axle – Rear (parallel) Blade		
Counterweight	4.3 mt			4.3 mt		
Boom Type	Offset	VA		Offset	VA	
Stick Length	2.45 m (8'0")	2.45 m (8'0")	2.60 m (8'6")	2.45 m (8'0")	2.45 m (8'0")	2.60 m (8'6")
H110E S	✓	✓	✓	✓	✓	✓
H115 GC S	✓	✓		✓	✓	
H115E S	✓	✓	✓	✓	✓	✓

(continued on next page)

Matching – Wheeled Excavators (continued)

Match
 Working Range Front Only
 Allowed Usage on Machine Less Than 50%
 No Match

M317F (continued)

CW-20 Dedicated Coupler

Undercarriage	Front (parallel) Blade; Rear Outriggers			Front Outriggers; Rear (parallel) Blade		
Counterweight	4.3 mt			4.3 mt		
Boom Type	Offset	VA		Offset	VA	
Stick Length	2.45 m (8'0")	2.45 m (8'0")	2.60 m (8'6")	2.45 m (8'0")	2.45 m (8'0")	2.60 m (8'6")
H110E S	✓	✓	✓	✓	✓	✓
H115 GC	✓	✓		✓	✓	
H115E S	✓	✓	✓	✓	✓	✓

CW-20 Dedicated Coupler (continued)

Undercarriage	Rear (parallel) Blade			Wide Axle – Rear (parallel) Blade		
Counterweight	4.3 mt			4.3 mt		
Boom Type	Offset	VA		Offset	VA	
Stick Length	2.45 m (8'0")	2.45 m (8'0")	2.60 m (8'6")	2.45 m (8'0")	2.45 m (8'0")	2.60 m (8'6")
H110E S	✓	✓	✓	✓	✓	✓
H115 GC	✓	✓		✓	✓	
H115E S	✓	✓	✓	✓	✓	✓

M318F

Pin-on

Undercarriage	Front and Rear Outriggers					
Counterweight	3.4 mt					
Boom Type	1 PC			VA		
Stick Length	2.10 m (6'11")	2.40 m (7'10")	2.60 m (8'6")	2.10 m (6'11")	2.40 m (7'10")	2.60 m (8'6")
H110E S	✓	✓	✓	✓	✓	✓
H115 GC	✓	✓	✓	✓	✓	✓
H115 GC S	✓	✓	✓	✓	✓	✓
H115E S	✓	✓	✓	✓	✓	✓
H120E S	✓	✓	✓	✓	✓	✓

Pin-on (continued)

Undercarriage	Front and Rear Outriggers					
Counterweight	3.9 mt					
Boom Type	1 PC			VA		
Stick Length	2.10 m (6'11")	2.40 m (7'10")	2.60 m (8'6")	2.10 m (6'11")	2.40 m (7'10")	2.60 m (8'6")
H110E S	✓	✓	✓	✓	✓	✓
H115 GC	✓	✓	✓	✓	✓	✓
H115 GC S	✓	✓	✓	✓	✓	✓
H115E S	✓	✓	✓	✓	✓	✓
H120E S	✓	✓	✓	✓	✓	✓

(continued on next page)

Hammer Technical Specifications

Matching – Wheeled Excavators (continued)

Match
 * Working Range Front Only
 † Allowed Usage on Machine Less Than 50%
 No Match

M318F (continued)

Pin-on (continued)

Undercarriage	Front Outriggers; Rear Blade (Wide U/C)					
Counterweight	3.4 mt					
Boom Type	1 PC			VA		
Stick Length	2.10 m (6'11")	2.40 m (7'10")	2.60 m (8'6")	2.10 m (6'11")	2.40 m (7'10")	2.60 m (8'6")
H110E S	✓	✓	✓	✓	✓	✓
H115 GC	✓	✓	✓	✓	✓	✓
H115 GC S	✓	✓	✓	✓	✓	✓
H115E S	✓	✓	✓	✓	✓	✓
H120E S	✓	✓	✓	✓	✓	✓

Pin-on (continued)

Undercarriage	Front Outriggers; Rear Blade (Wide U/C)					
Counterweight	3.9 mt					
Boom Type	1 PC			VA		
Stick Length	2.10 m (6'11")	2.40 m (7'10")	2.60 m (8'6")	2.10 m (6'11")	2.40 m (7'10")	2.60 m (8'6")
H110E S	✓	✓	✓	✓	✓	✓
H115 GC	✓	✓	✓	✓	✓	✓
H115 GC S	✓	✓	✓	✓	✓	✓
H115E S	✓	✓	✓	✓	✓	✓
H120E S	✓	✓	✓	✓	✓	✓

Pin-on (continued)

Undercarriage	Front Outriggers; Rear Blade					
Counterweight	3.4 mt					
Boom Type	1 PC			VA		
Stick Length	2.10 m (6'11")	2.40 m (7'10")	2.60 m (8'6")	2.10 m (6'11")	2.40 m (7'10")	2.60 m (8'6")
H110E S	✓	✓	✓	✓	✓	✓
H115 GC	✓	✓	✓	✓	✓	✓
H115 GC S	✓	✓	✓	✓	✓	✓
H115E S	✓	✓	✓	✓	✓	✓
H120E S	✓	✓	✓	✓	✓	✓

Pin-on (continued)

Undercarriage	Front Outriggers; Rear Blade					
Counterweight	3.9 mt					
Boom Type	1 PC			VA		
Stick Length	2.10 m (6'11")	2.40 m (7'10")	2.60 m (8'6")	2.10 m (6'11")	2.40 m (7'10")	2.60 m (8'6")
H110E S	✓	✓	✓	✓	✓	✓
H115 GC	✓	✓	✓	✓	✓	✓
H115 GC S	✓	✓	✓	✓	✓	✓
H115E S	✓	✓	✓	✓	✓	✓
H120E S	✓	✓	✓	✓	✓	✓

(continued on next page)

Hammer Technical Specifications

Matching – Wheeled Excavators (continued)

Match
 * Working Range Front Only
 † Allowed Usage on Machine Less Than 50%
 No Match

M318F (continued)

Pin-on (continued)

Undercarriage	Rear Blade					
Counterweight	3.4 mt					
Boom Type	1 PC			VA		
Stick Length	2.10 m (6'11")	2.40 m (7'10")	2.60 m (8'6")	2.10 m (6'11")	2.40 m (7'10")	2.60 m (8'6")
H110E S	✓	✓	✓	✓	✓	✓
H115 GC	✓	✓	✓	✓	✓	✓
H115 GC S	✓	✓	✓	✓	✓	✓
H115E S	✓	✓	✓	✓	✓	✓
H120E S		✓	✓	✓	✓	✓*

Pin-on (continued)

Undercarriage	Rear Blade					
Counterweight	3.9 mt					
Boom Type	1 PC			VA		
Stick Length	2.10 m (6'11")	2.40 m (7'10")	2.60 m (8'6")	2.10 m (6'11")	2.40 m (7'10")	2.60 m (8'6")
H110E S	✓	✓	✓	✓	✓	✓
H115 GC	✓	✓	✓	✓	✓	✓
H115 GC S	✓	✓	✓	✓	✓	✓
H115E S	✓	✓	✓	✓	✓	✓
H120E S	✓	✓	✓	✓	✓	✓

Pin-on (continued)

Undercarriage	Rear Blade (Wide U/C)					
Counterweight	3.4 mt					
Boom Type	1 PC			VA		
Stick Length	2.10 m (6'11")	2.40 m (7'10")	2.60 m (8'6")	2.10 m (6'11")	2.40 m (7'10")	2.60 m (8'6")
H110E S	✓	✓	✓	✓	✓	✓
H115 GC	✓	✓	✓	✓	✓	✓
H115 GC S	✓	✓	✓	✓	✓	✓
H115E S	✓	✓	✓	✓	✓	✓
H120E S	✓	✓	✓	✓	✓	✓

Pin-on (continued)

Undercarriage	Rear Blade (Wide U/C)					
Counterweight	3.9 mt					
Boom Type	1 PC			VA		
Stick Length	2.10 m (6'11")	2.40 m (7'10")	2.60 m (8'6")	2.10 m (6'11")	2.40 m (7'10")	2.60 m (8'6")
H110E S	✓	✓	✓	✓	✓	✓
H115 GC	✓	✓	✓	✓	✓	✓
H115 GC S	✓	✓	✓	✓	✓	✓
H115E S	✓	✓	✓	✓	✓	✓
H120E S	✓	✓	✓	✓	✓	✓

(continued on next page)

Hammer Technical Specifications

Matching – Wheeled Excavators *(continued)*

Match
 * Working Range Front Only
 † Allowed Usage on Machine Less Than 50%
 No Match

M318F *(continued)*

Cat Pin Grabber Coupler

Undercarriage	Front and Rear Outriggers					
Counterweight	3.4 mt					
Boom Type	1 PC			VA		
Stick Length	2.10 m (6'11")	2.40 m (7'10")	2.60 m (8'6")	2.10 m (6'11")	2.40 m (7'10")	2.60 m (8'6")
H110E S	✓	✓	✓	✓	✓	✓
H115 GC	✓	✓	✓	✓	✓	✓
H115 GC S	✓	✓	✓	✓	✓	✓
H115E S	✓	✓	✓	✓	✓	✓
H120E S	✓	✓	✓	✓	✓	✓

Cat Pin Grabber Coupler *(continued)*

Undercarriage	Front and Rear Outriggers					
Counterweight	3.9 mt					
Boom Type	1 PC			VA		
Stick Length	2.10 m (6'11")	2.40 m (7'10")	2.60 m (8'6")	2.10 m (6'11")	2.40 m (7'10")	2.60 m (8'6")
H110E S	✓	✓	✓	✓	✓	✓
H115 GC	✓	✓	✓	✓	✓	✓
H115 GC S	✓	✓	✓	✓	✓	✓
H115E S	✓	✓	✓	✓	✓	✓
H120E S	✓	✓	✓	✓	✓	✓

Cat Pin Grabber Coupler *(continued)*

Undercarriage	Front Outriggers; Rear Blade (Wide U/C)					
Counterweight	3.4 mt					
Boom Type	1 PC			VA		
Stick Length	2.10 m (6'11")	2.40 m (7'10")	2.60 m (8'6")	2.10 m (6'11")	2.40 m (7'10")	2.60 m (8'6")
H110E S	✓	✓	✓	✓	✓	✓
H115 GC	✓	✓	✓	✓	✓	✓
H115 GC S	✓	✓	✓	✓	✓	✓
H115E S	✓	✓	✓	✓	✓	✓
H120E S	✓	✓	✓	✓	✓	✓

Cat Pin Grabber Coupler *(continued)*

Undercarriage	Front Outriggers; Rear Blade (Wide U/C)					
Counterweight	3.9 mt					
Boom Type	1 PC			VA		
Stick Length	2.10 m (6'11")	2.40 m (7'10")	2.60 m (8'6")	2.10 m (6'11")	2.40 m (7'10")	2.60 m (8'6")
H110E S	✓	✓	✓	✓	✓	✓
H115 GC	✓	✓	✓	✓	✓	✓
H115 GC S	✓	✓	✓	✓	✓	✓
H115E S	✓	✓	✓	✓	✓	✓
H120E S	✓	✓	✓	✓	✓	✓

(continued on next page)

Matching – Wheeled Excavators *(continued)*

Match
 Working Range Front Only
 Allowed Usage on Machine Less Than 50%
 No Match

M318F *(continued)*

Cat Pin Grabber Coupler *(continued)*

Undercarriage	Front Outriggers; Rear Blade					
Counterweight	3.4 mt					
Boom Type	1 PC			VA		
Stick Length	2.10 m (6'11")	2.40 m (7'10")	2.60 m (8'6")	2.10 m (6'11")	2.40 m (7'10")	2.60 m (8'6")
H110E S	✓	✓	✓	✓	✓	✓
H115 GC	✓	✓	✓	✓	✓	✓
H115 GC S	✓	✓	✓	✓	✓	✓
H115E S	✓	✓	✓	✓	✓	✓
H120E S	✓	✓	✓	✓	✓	✓

Cat Pin Grabber Coupler *(continued)*

Undercarriage	Front Outriggers; Rear Blade					
Counterweight	3.9 mt					
Boom Type	1 PC			VA		
Stick Length	2.10 m (6'11")	2.40 m (7'10")	2.60 m (8'6")	2.10 m (6'11")	2.40 m (7'10")	2.60 m (8'6")
H110E S	✓	✓	✓	✓	✓	✓
H115 GC	✓	✓	✓	✓	✓	✓
H115 GC S	✓	✓	✓	✓	✓	✓
H115E S	✓	✓	✓	✓	✓	✓
H120E S	✓	✓	✓	✓	✓	✓

Cat Pin Grabber Coupler *(continued)*

Undercarriage	Rear Blade					
Counterweight	3.4 mt					
Boom Type	1 PC			VA		
Stick Length	2.10 m (6'11")	2.40 m (7'10")	2.60 m (8'6")	2.10 m (6'11")	2.40 m (7'10")	2.60 m (8'6")
H110E S	✓	✓	✓	✓	✓	✓
H115 GC	✓	✓	✓	✓	✓*	✓*
H115 GC S	✓	✓	✓	✓	✓	✓*
H115E S	✓	✓	✓	✓	✓	✓
H120E S	✓*	✓*				

Cat Pin Grabber Coupler *(continued)*

Undercarriage	Rear Blade					
Counterweight	3.9 mt					
Boom Type	1 PC			VA		
Stick Length	2.10 m (6'11")	2.40 m (7'10")	2.60 m (8'6")	2.10 m (6'11")	2.40 m (7'10")	2.60 m (8'6")
H110E S	✓	✓	✓	✓	✓	✓
H115 GC	✓	✓	✓	✓	✓	✓
H115 GC S	✓	✓	✓	✓	✓	✓
H115E S	✓	✓	✓	✓	✓	✓
H120E S	✓	✓	✓*	✓*	✓*	

(continued on next page)

Hammer Technical Specifications

Matching – Wheeled Excavators *(continued)*

Match
 * Working Range Front Only
 † Allowed Usage on Machine Less Than 50%
 No Match

M318F *(continued)*

Cat Pin Grabber Coupler *(continued)*

Undercarriage	Rear Blade (Wide U/C)					
Counterweight	3.4 mt					
Boom Type	1 PC			VA		
Stick Length	2.10 m (6'11")	2.40 m (7'10")	2.60 m (8'6")	2.10 m (6'11")	2.40 m (7'10")	2.60 m (8'6")
H110E S	✓	✓	✓	✓	✓	✓
H115 GC	✓	✓	✓	✓	✓	✓
H115 GC S	✓	✓	✓	✓	✓	✓
H115E S	✓	✓	✓	✓	✓	✓
H120E S	✓	✓	✓	✓	✓*	

Cat Pin Grabber Coupler *(continued)*

Undercarriage	Rear Blade (Wide U/C)					
Counterweight	3.9 mt					
Boom Type	1 PC			VA		
Stick Length	2.10 m (6'11")	2.40 m (7'10")	2.60 m (8'6")	2.10 m (6'11")	2.40 m (7'10")	2.60 m (8'6")
H110E S	✓	✓	✓	✓	✓	✓
H115 GC	✓	✓	✓	✓	✓	✓
H115 GC S	✓	✓	✓	✓	✓	✓
H115E S	✓	✓	✓	✓	✓	✓
H120E S	✓	✓	✓	✓	✓	✓

CW-20 S Dedicated Coupler

Undercarriage	Front and Rear Outriggers					
Counterweight	3.4 mt					
Boom Type	1 PC			VA		
Stick Length	2.10 m (6'11")	2.40 m (7'10")	2.60 m (8'6")	2.10 m (6'11")	2.40 m (7'10")	2.60 m (8'6")
H110E S	✓	✓	✓	✓	✓	✓
H115 GC S	✓	✓	✓	✓	✓	✓
H115E S	✓	✓	✓	✓	✓	✓
H120E S	✓	✓	✓			

CW-20 S Dedicated Coupler *(continued)*

Undercarriage	Front and Rear Outriggers					
Counterweight	3.9 mt					
Boom Type	1 PC			VA		
Stick Length	2.10 m (6'11")	2.40 m (7'10")	2.60 m (8'6")	2.10 m (6'11")	2.40 m (7'10")	2.60 m (8'6")
H110E S	✓	✓	✓	✓	✓	✓
H115 GC S	✓	✓	✓	✓	✓	✓
H115E S	✓	✓	✓	✓	✓	✓
H120E S	✓	✓	✓			

(continued on next page)

Matching – Wheeled Excavators *(continued)*

Match
 Working Range Front Only
 Allowed Usage on Machine Less Than 50%
 No Match

M318F *(continued)*

CW-20 S Dedicated Coupler *(continued)*

Undercarriage	Front Outriggers; Rear Blade (Wide U/C)					
Counterweight	3.4 mt					
Boom Type	1 PC			VA		
Stick Length	2.10 m (6'11")	2.40 m (7'10")	2.60 m (8'6")	2.10 m (6'11")	2.40 m (7'10")	2.60 m (8'6")
H110E S	✓	✓	✓	✓	✓	✓
H115 GC S	✓	✓	✓	✓	✓	✓
H115E S	✓	✓	✓	✓	✓	✓
H120E S	✓	✓	✓			

CW-20 S Dedicated Coupler *(continued)*

Undercarriage	Front Outriggers; Rear Blade (Wide U/C)					
Counterweight	3.9 mt					
Boom Type	1 PC			VA		
Stick Length	2.10 m (6'11")	2.40 m (7'10")	2.60 m (8'6")	2.10 m (6'11")	2.40 m (7'10")	2.60 m (8'6")
H110E S	✓	✓	✓	✓	✓	✓
H115 GC S	✓	✓	✓	✓	✓	✓
H115E S	✓	✓	✓	✓	✓	✓
H120E S	✓	✓	✓			

CW-20 S Dedicated Coupler *(continued)*

Undercarriage	Front Outriggers; Rear Blade					
Counterweight	3.4 mt					
Boom Type	1 PC			VA		
Stick Length	2.10 m (6'11")	2.40 m (7'10")	2.60 m (8'6")	2.10 m (6'11")	2.40 m (7'10")	2.60 m (8'6")
H110E S	✓	✓	✓	✓	✓	✓
H115 GC S	✓	✓	✓	✓	✓	✓
H115E S	✓	✓	✓	✓	✓	✓
H120E S	✓	✓	✓			

CW-20 S Dedicated Coupler *(continued)*

Undercarriage	Front Outriggers; Rear Blade					
Counterweight	3.9 mt					
Boom Type	1 PC			VA		
Stick Length	2.10 m (6'11")	2.40 m (7'10")	2.60 m (8'6")	2.10 m (6'11")	2.40 m (7'10")	2.60 m (8'6")
H110E S	✓	✓	✓	✓	✓	✓
H115 GC S	✓	✓	✓	✓	✓	✓
H115E S	✓	✓	✓	✓	✓	✓
H120E S	✓	✓	✓			

(continued on next page)

Hammer Technical Specifications

Matching – Wheeled Excavators (continued)

Match
 Working Range Front Only
 Allowed Usage on Machine Less Than 50%
 No Match

M318F (continued)

CW-20 S Dedicated Coupler (continued)

Undercarriage	Rear Blade					
Counterweight	3.4 mt					
Boom Type	1 PC			VA		
Stick Length	2.10 m (6'11")	2.40 m (7'10")	2.60 m (8'6")	2.10 m (6'11")	2.40 m (7'10")	2.60 m (8'6")
H110E S	✓	✓	✓	✓	✓	✓
H115 GC S	✓	✓	✓	✓	✓	✓*
H115E S	✓*	✓	✓	✓	✓	✓
H120E S		✓*	✓*			

CW-20 S Dedicated Coupler (continued)

Undercarriage	Rear Blade					
Counterweight	3.9 mt					
Boom Type	1 PC			VA		
Stick Length	2.10 m (6'11")	2.40 m (7'10")	2.60 m (8'6")	2.10 m (6'11")	2.40 m (7'10")	2.60 m (8'6")
H110E S	✓	✓	✓	✓	✓	✓
H115 GC S	✓	✓	✓	✓	✓	✓
H115E S	✓	✓	✓	✓	✓	✓
H120E S	✓	✓	✓			

CW-20 S Dedicated Coupler (continued)

Undercarriage	Rear Blade (Wide U/C)					
Counterweight	3.4 mt					
Boom Type	1 PC			VA		
Stick Length	2.10 m (6'11")	2.40 m (7'10")	2.60 m (8'6")	2.10 m (6'11")	2.40 m (7'10")	2.60 m (8'6")
H110E S	✓	✓	✓	✓	✓	✓
H115 GC S	✓	✓	✓	✓	✓	✓
H115E S	✓	✓	✓	✓	✓	✓
H120E S	✓	✓	✓			

CW-20 S Dedicated Coupler (continued)

Undercarriage	Rear Blade (Wide U/C)					
Counterweight	3.9 mt					
Boom Type	1 PC			VA		
Stick Length	2.10 m (6'11")	2.40 m (7'10")	2.60 m (8'6")	2.10 m (6'11")	2.40 m (7'10")	2.60 m (8'6")
H110E S	✓	✓	✓	✓	✓	✓
H115 GC S	✓	✓	✓	✓	✓	✓
H115E S	✓	✓	✓	✓	✓	✓
H120E S	✓	✓	✓			

CW-20 Dedicated Coupler

Undercarriage	Front and Rear Outriggers					
Counterweight	3.4 mt					
Boom Type	1 PC			VA		
Stick Length	2.10 m (6'11")	2.40 m (7'10")	2.60 m (8'6")	2.10 m (6'11")	2.40 m (7'10")	2.60 m (8'6")
H110E S	✓	✓	✓	✓	✓	✓
H115 GC	✓	✓	✓	✓	✓	✓
H115E S	✓	✓	✓	✓	✓	✓
H120E S	✓	✓	✓			

(continued on next page)

Matching – Wheeled Excavators (continued)

Match
 Working Range Front Only
 Allowed Usage on Machine Less Than 50%
 No Match

M318F (continued)

CW-20 Dedicated Coupler (continued)

Undercarriage	Front and Rear Outriggers					
Counterweight	3.9 mt					
Boom Type	1 PC			VA		
Stick Length	2.10 m (6'11")	2.40 m (7'10")	2.60 m (8'6")	2.10 m (6'11")	2.40 m (7'10")	2.60 m (8'6")
H110E S	✓	✓	✓	✓	✓	✓
H115 GC	✓	✓	✓	✓	✓	✓
H115E S	✓	✓	✓	✓	✓	✓
H120E S	✓	✓	✓			

CW-20 Dedicated Coupler (continued)

Undercarriage	Front Outriggers; Rear Blade (Wide U/C)					
Counterweight	3.4 mt					
Boom Type	1 PC			VA		
Stick Length	2.10 m (6'11")	2.40 m (7'10")	2.60 m (8'6")	2.10 m (6'11")	2.40 m (7'10")	2.60 m (8'6")
H110E S	✓	✓	✓	✓	✓	✓
H115 GC	✓	✓	✓	✓	✓	✓
H115E S	✓	✓	✓	✓	✓	✓
H120E S	✓	✓	✓			

CW-20 Dedicated Coupler (continued)

Undercarriage	Front Outriggers; Rear Blade (Wide U/C)					
Counterweight	3.9 mt					
Boom Type	1 PC			VA		
Stick Length	2.10 m (6'11")	2.40 m (7'10")	2.60 m (8'6")	2.10 m (6'11")	2.40 m (7'10")	2.60 m (8'6")
H110E S	✓	✓	✓	✓	✓	✓
H115 GC	✓	✓	✓	✓	✓	✓
H115E S	✓	✓	✓	✓	✓	✓
H120E S	✓	✓	✓			

CW-20 Dedicated Coupler (continued)

Undercarriage	Front Outriggers; Rear Blade					
Counterweight	3.4 mt					
Boom Type	1 PC			VA		
Stick Length	2.10 m (6'11")	2.40 m (7'10")	2.60 m (8'6")	2.10 m (6'11")	2.40 m (7'10")	2.60 m (8'6")
H110E S	✓	✓	✓	✓	✓	✓
H115 GC	✓	✓	✓	✓	✓	✓
H115E S	✓	✓	✓	✓	✓	✓
H120E S	✓	✓	✓			

CW-20 Dedicated Coupler (continued)

Undercarriage	Front Outriggers; Rear Blade					
Counterweight	3.9 mt					
Boom Type	1 PC			VA		
Stick Length	2.10 m (6'11")	2.40 m (7'10")	2.60 m (8'6")	2.10 m (6'11")	2.40 m (7'10")	2.60 m (8'6")
H110E S	✓	✓	✓	✓	✓	✓
H115 GC	✓	✓	✓	✓	✓	✓
H115E S	✓	✓	✓	✓	✓	✓
H120E S	✓	✓	✓			

(continued on next page)

Hammer Technical Specifications

Matching – Wheeled Excavators *(continued)*

Match
 * Working Range Front Only
 † Allowed Usage on Machine Less Than 50%
 No Match

M318F *(continued)*

CW-20 Dedicated Coupler *(continued)*

Undercarriage	Rear Blade					
Counterweight	3.4 mt					
Boom Type	1 PC			VA		
Stick Length	2.10 m (6'11")	2.40 m (7'10")	2.60 m (8'6")	2.10 m (6'11")	2.40 m (7'10")	2.60 m (8'6")
H110E S	✓	✓	✓	✓	✓	✓
H115 GC	✓	✓	✓	✓	✓	✓
H115E S	✓*	✓	✓	✓	✓	✓
H120E S		✓*				

CW-20 Dedicated Coupler *(continued)*

Undercarriage	Rear Blade					
Counterweight	3.9 mt					
Boom Type	1 PC			VA		
Stick Length	2.10 m (6'11")	2.40 m (7'10")	2.60 m (8'6")	2.10 m (6'11")	2.40 m (7'10")	2.60 m (8'6")
H110E S	✓	✓	✓	✓	✓	✓
H115 GC	✓	✓	✓	✓	✓	✓
H115E S	✓	✓	✓	✓	✓	✓
H120E S	✓	✓	✓			

CW-20 Dedicated Coupler *(continued)*

Undercarriage	Rear Blade (Wide U/C)					
Counterweight	3.4 mt					
Boom Type	1 PC			VA		
Stick Length	2.10 m (6'11")	2.40 m (7'10")	2.60 m (8'6")	2.10 m (6'11")	2.40 m (7'10")	2.60 m (8'6")
H110E S	✓	✓	✓	✓	✓	✓
H115 GC	✓	✓	✓	✓	✓	✓
H115E S	✓	✓	✓	✓	✓	✓
H120E S	✓	✓	✓			

CW-20 Dedicated Coupler *(continued)*

Undercarriage	Rear Blade (Wide U/C)					
Counterweight	3.9 mt					
Boom Type	1 PC			VA		
Stick Length	2.10 m (6'11")	2.40 m (7'10")	2.60 m (8'6")	2.10 m (6'11")	2.40 m (7'10")	2.60 m (8'6")
H110E S	✓	✓	✓	✓	✓	✓
H115 GC	✓	✓	✓	✓	✓	✓
H115E S	✓	✓	✓	✓	✓	✓
H120E S	✓	✓	✓			

(continued on next page)

Matching – Wheeled Excavators *(continued)*

Match
 Working Range Front Only
 Allowed Usage on Machine Less Than 50%
 No Match

M320D2

Pin-on

Undercarriage	Front and Rear Outriggers				Front Outriggers; Rear Blade			
Counterweight	4.0 mt				4.0 mt			
Boom Type	1 PC		VA		1 PC		VA	
Stick Length	2.50 m (8'2")	2.80 m (9'2")	2.50 m (8'2")	2.80 m (9'2")	2.50 m (8'2")	2.80 m (9'2")	2.50 m (8'2")	2.80 m (9'2")
H115E S	✓	✓	✓	✓	✓	✓	✓	✓
H120 GC	✓	✓	✓	✓	✓	✓	✓	✓
H120 GC Side-mount	✓	✓	✓	✓	✓	✓	✓	✓
H120 GC S	✓	✓	✓	✓	✓	✓	✓	✓
H120E S	✓	✓	✓	✓	✓	✓	✓	✓
H130E S	✓	✓	✓	✓	✓	✓	✓	✓

Pin-on *(continued)*

Undercarriage	Rear Blade			
Counterweight	4.0 mt			
Boom Type	1 PC		VA	
Stick Length	2.50 m (8'2")	2.80 m (9'2")	2.50 m (8'2")	2.80 m (9'2")
H115E S	✓	✓	✓	✓
H120 GC	✓	✓*	✓	✓*
H120 GC Side-mount	✓	✓	✓	✓
H120 GC S	✓	✓	✓	✓
H120E S	✓	✓	✓	✓
H130E S	✓	✓*	✓	✓*

Cat Pin Grabber Coupler

Undercarriage	Front and Rear Outriggers				Front Outriggers; Rear Blade			
Counterweight	4.0 mt				4.0 mt			
Boom Type	1 PC		VA		1 PC		VA	
Stick Length	2.50 m (8'2")	2.80 m (9'2")	2.50 m (8'2")	2.80 m (9'2")	2.50 m (8'2")	2.80 m (9'2")	2.50 m (8'2")	2.80 m (9'2")
H115E S	✓	✓	✓	✓	✓	✓	✓	✓
H120 GC	✓	✓	✓		✓	✓	✓	
H120 GC Side-mount	✓	✓			✓	✓		
H120 GC S	✓	✓	✓	✓	✓	✓	✓	✓
H120E S	✓	✓	✓	✓	✓	✓	✓	✓
H130E S	✓		✓		✓		✓	

Cat Pin Grabber Coupler *(continued)*

Undercarriage	Rear Blade			
Counterweight	4.0 mt			
Boom Type	1 PC		VA	
Stick Length	2.50 m (8'2")	2.80 m (9'2")	2.50 m (8'2")	2.80 m (9'2")
H115E S	✓	✓	✓	✓
H120 GC				
H120 GC Side-mount				
H120 GC S				
H120E S	✓*		✓*	
H130E S				

(continued on next page)

Hammer Technical Specifications

Matching – Wheeled Excavators (continued)

Match
 Working Range Front Only
 Allowed Usage on Machine Less Than 50%
 No Match

M320D2 (continued)

CW-30 S Dedicated Coupler

Undercarriage	Front and Rear Outriggers				Front Outriggers; Rear Blade			
Counterweight	4.0 mt				4.0 mt			
Boom Type	1 PC		VA		1 PC		VA	
Stick Length	2.50 m (8'2")	2.80 m (9'2")	2.50 m (8'2")	2.80 m (9'2")	2.50 m (8'2")	2.80 m (9'2")	2.50 m (8'2")	2.80 m (9'2")
H115E S	✓	✓	✓	✓	✓	✓	✓	✓
H120 GC	✓	✓	✓	✓	✓	✓	✓	✓
H120 GC S	✓	✓	✓	✓	✓	✓	✓	✓
H120E S	✓	✓	✓	✓	✓	✓	✓	✓

CW-30 S Dedicated Coupler (continued)

Undercarriage	Rear Blade			
Counterweight	4.0 mt			
Boom Type	1 PC		VA	
Stick Length	2.50 m (8'2")	2.80 m (9'2")	2.50 m (8'2")	2.80 m (9'2")
H115E S	✓	✓	✓	✓
H120 GC				
H120 GC S	✓*		✓*	
H120E S	✓	✓*	✓	✓*

CW-30 Dedicated Coupler

Undercarriage	Front and Rear Outriggers				Front Outriggers; Rear Blade			
Counterweight	4.0 mt				4.0 mt			
Boom Type	1 PC		VA		1 PC		VA	
Stick Length	2.50 m (8'2")	2.80 m (9'2")	2.50 m (8'2")	2.80 m (9'2")	2.50 m (8'2")	2.80 m (9'2")	2.50 m (8'2")	2.80 m (9'2")
H115E S	✓	✓	✓	✓	✓	✓	✓	✓
H120 GC	✓	✓	✓	✓	✓	✓	✓	✓
H120 GC S	✓	✓	✓	✓	✓	✓	✓	✓
H120E S	✓	✓	✓	✓	✓	✓	✓	✓
H130E S	✓				✓			

CW-30 Dedicated Coupler (continued)

Undercarriage	Rear Blade			
Counterweight	4.0 mt			
Boom Type	1 PC		VA	
Stick Length	2.50 m (8'2")	2.80 m (9'2")	2.50 m (8'2")	2.80 m (9'2")
H115E S	✓	✓	✓	✓
H120 GC				
H120 GC S	✓*		✓*	
H120E S	✓	✓*	✓	✓*
H130E S				

(continued on next page)

Hammer Technical Specifications

Matching – Wheeled Excavators (continued)

Match
 Working Range Front Only
 Allowed Usage on Machine Less Than 50%
 No Match

M320F

Pin-on

Undercarriage	Front and Rear Outriggers							
Counterweight	3.7 mt				4.2 mt			
Boom Type	1 PC		VA		1 PC		VA	
Stick Length	2.50 m (8'2")	2.80 m (9'2")	2.50 m (8'2")	2.80 m (9'2")	2.50 m (8'2")	2.80 m (9'2")	2.50 m (8'2")	2.80 m (9'2")
H115E S	✓	✓	✓	✓	✓	✓	✓	✓
H120 GC	✓	✓	✓	✓	✓	✓	✓	✓
H120 GC S	✓	✓	✓	✓	✓	✓	✓	✓
H120E S	✓	✓	✓	✓	✓	✓	✓	✓
H130E S	✓	✓	✓	✓	✓	✓	✓	✓

Pin-on (continued)

Undercarriage	Front Outriggers; Rear Blade (Wide U/C)							
Counterweight	3.7 mt				4.2 mt			
Boom Type	1 PC		VA		1 PC		VA	
Stick Length	2.50 m (8'2")	2.80 m (9'2")	2.50 m (8'2")	2.80 m (9'2")	2.50 m (8'2")	2.80 m (9'2")	2.50 m (8'2")	2.80 m (9'2")
H115E S	✓	✓	✓	✓	✓	✓	✓	✓
H120 GC	✓	✓	✓	✓	✓	✓	✓	✓
H120 GC S	✓	✓	✓	✓	✓	✓	✓	✓
H120E S	✓	✓	✓	✓	✓	✓	✓	✓
H130E S	✓	✓	✓	✓	✓	✓	✓	✓

Pin-on (continued)

Undercarriage	Front Outriggers; Rear Blade							
Counterweight	3.7 mt				4.2 mt			
Boom Type	1 PC		VA		1 PC		VA	
Stick Length	2.50 m (8'2")	2.80 m (9'2")	2.50 m (8'2")	2.80 m (9'2")	2.50 m (8'2")	2.80 m (9'2")	2.50 m (8'2")	2.80 m (9'2")
H115E S	✓	✓	✓	✓	✓	✓	✓	✓
H120 GC	✓	✓	✓	✓	✓	✓	✓	✓
H120 GC S	✓	✓	✓	✓	✓	✓	✓	✓
H120E S	✓	✓	✓	✓	✓	✓	✓	✓
H130E S	✓	✓	✓	✓	✓	✓	✓	✓

Pin-on (continued)

Undercarriage	Rear Blade							
Counterweight	3.7 mt				4.2 mt			
Boom Type	1 PC		VA		1 PC		VA	
Stick Length	2.50 m (8'2")	2.80 m (9'2")	2.50 m (8'2")	2.80 m (9'2")	2.50 m (8'2")	2.80 m (9'2")	2.50 m (8'2")	2.80 m (9'2")
H115E S	✓	✓	✓	✓	✓	✓	✓	✓
H120 GC	✓*	✓*	✓*		✓	✓	✓	✓*
H120 GC S	✓	✓*	✓	✓*	✓	✓	✓	✓
H120E S	✓	✓	✓	✓	✓	✓	✓	✓
H130E S	✓*		✓*		✓	✓	✓	✓*

(continued on next page)

Hammer Technical Specifications

Matching – Wheeled Excavators (continued)

Match
 Working Range Front Only
 Allowed Usage on Machine Less Than 50%
 No Match

M320F (continued)

Pin-on (continued)

Undercarriage	Rear Blade (Wide U/C)							
Counterweight	3.7 mt				4.2 mt			
Boom Type	1 PC		VA		1 PC		VA	
Stick Length	2.50 m (8'2")	2.80 m (9'2")	2.50 m (8'2")	2.80 m (9'2")	2.50 m (8'2")	2.80 m (9'2")	2.50 m (8'2")	2.80 m (9'2")
H115E S	✓	✓	✓	✓	✓	✓	✓	✓
H120 GC	✓	✓	✓	✓	✓	✓	✓	✓
H120 GC S	✓	✓	✓	✓	✓	✓	✓	✓
H120E S	✓	✓	✓	✓	✓	✓	✓	✓
H130E S	✓	✓	✓	✓*	✓	✓	✓	✓

Cat Pin Grabber Coupler

Undercarriage	Front and Rear Outriggers							
Counterweight	3.7 mt				4.2 mt			
Boom Type	1 PC		VA		1 PC		VA	
Stick Length	2.50 m (8'2")	2.80 m (9'2")	2.50 m (8'2")	2.80 m (9'2")	2.50 m (8'2")	2.80 m (9'2")	2.50 m (8'2")	2.80 m (9'2")
H115E S	✓	✓	✓	✓	✓	✓	✓	✓
H120 GC	✓	✓	✓		✓	✓	✓	
H120 GC S	✓	✓	✓		✓	✓	✓	
H120E S	✓	✓	✓	✓	✓	✓	✓	✓
H130E S	✓	✓	✓		✓	✓	✓	

Cat Pin Grabber Coupler (continued)

Undercarriage	Front Outriggers; Rear Blade (Wide U/C)							
Counterweight	3.7 mt				4.2 mt			
Boom Type	1 PC		VA		1 PC		VA	
Stick Length	2.50 m (8'2")	2.80 m (9'2")	2.50 m (8'2")	2.80 m (9'2")	2.50 m (8'2")	2.80 m (9'2")	2.50 m (8'2")	2.80 m (9'2")
H115E S	✓	✓	✓	✓	✓	✓	✓	✓
H120 GC	✓	✓	✓		✓	✓	✓	
H120 GC S	✓	✓	✓		✓	✓	✓	
H120E S	✓	✓	✓	✓	✓	✓	✓	✓
H130E S	✓		✓		✓		✓	

Cat Pin Grabber Coupler (continued)

Undercarriage	Front Outriggers; Rear Blade							
Counterweight	3.7 mt				4.2 mt			
Boom Type	1 PC		VA		1 PC		VA	
Stick Length	2.50 m (8'2")	2.80 m (9'2")	2.50 m (8'2")	2.80 m (9'2")	2.50 m (8'2")	2.80 m (9'2")	2.50 m (8'2")	2.80 m (9'2")
H115E S	✓	✓	✓	✓	✓	✓	✓	✓
H120 GC	✓	✓	✓		✓	✓	✓	
H120 GC S	✓	✓	✓		✓	✓	✓	
H120E S	✓	✓	✓	✓	✓	✓	✓	✓
H130E S	✓	✓	✓		✓	✓	✓	

(continued on next page)

Matching – Wheeled Excavators (continued)

Match
 * Working Range Front Only
 † Allowed Usage on Machine Less Than 50%
 No Match

M320F (continued)

Cat Pin Grabber Coupler (continued)

Undercarriage	Rear Blade							
	3.7 mt				4.2 mt			
	1 PC		VA		1 PC		VA	
Stick Length	2.50 m (8'2")	2.80 m (9'2")	2.50 m (8'2")	2.80 m (9'2")	2.50 m (8'2")	2.80 m (9'2")	2.50 m (8'2")	2.80 m (9'2")
H115E S	✓	✓	✓	✓	✓	✓	✓	✓
H120 GC								
H120 GC S								
H120E S					✓	✓*	✓*	
H130E S								

Cat Pin Grabber Coupler (continued)

Undercarriage	Rear Blade (Wide U/C)							
	3.7 mt				4.2 mt			
	1 PC		VA		1 PC		VA	
Stick Length	2.50 m (8'2")	2.80 m (9'2")	2.50 m (8'2")	2.80 m (9'2")	2.50 m (8'2")	2.80 m (9'2")	2.50 m (8'2")	2.80 m (9'2")
H115E S	✓	✓	✓	✓	✓	✓	✓	✓
H120 GC					✓*		✓*	
H120 GC S	✓*				✓	✓*	✓	
H120E S	✓	✓*	✓	✓*	✓	✓	✓	✓
H130E S					✓*		✓*	

CW-30 S Dedicated Coupler

Undercarriage	Front and Rear Outriggers							
	3.7 mt				4.2 mt			
	1 PC		VA		1 PC		VA	
Stick Length	2.50 m (8'2")	2.80 m (9'2")	2.50 m (8'2")	2.80 m (9'2")	2.50 m (8'2")	2.80 m (9'2")	2.50 m (8'2")	2.80 m (9'2")
H115E S	✓	✓	✓	✓	✓	✓	✓	✓
H120 GC S	✓	✓	✓	✓	✓	✓	✓	✓
H120E S	✓	✓	✓	✓	✓	✓	✓	✓
H130E S	✓	✓	✓	✓	✓	✓	✓	✓

CW-30 S Dedicated Coupler (continued)

Undercarriage	Front Outriggers; Rear Blade (Wide U/C)							
	3.7 mt				4.2 mt			
	1 PC		VA		1 PC		VA	
Stick Length	2.50 m (8'2")	2.80 m (9'2")	2.50 m (8'2")	2.80 m (9'2")	2.50 m (8'2")	2.80 m (9'2")	2.50 m (8'2")	2.80 m (9'2")
H115E S	✓	✓	✓	✓	✓	✓	✓	✓
H120 GC S	✓	✓	✓	✓	✓	✓	✓	✓
H120E S	✓	✓	✓	✓	✓	✓	✓	✓
H130E S	✓	✓	✓		✓	✓	✓	

(continued on next page)

Hammer Technical Specifications

Matching – Wheeled Excavators (continued)

Match
 Working Range Front Only
 Allowed Usage on Machine Less Than 50%
 No Match

M320F (continued)

CW-30 S Dedicated Coupler (continued)

Undercarriage	Front Outriggers; Rear Blade							
Counterweight	3.7 mt				4.2 mt			
Boom Type	1 PC		VA		1 PC		VA	
Stick Length	2.50 m (8'2")	2.80 m (9'2")	2.50 m (8'2")	2.80 m (9'2")	2.50 m (8'2")	2.80 m (9'2")	2.50 m (8'2")	2.80 m (9'2")
H115E S	✓	✓	✓	✓	✓	✓	✓	✓
H120 GC S	✓	✓	✓	✓	✓	✓	✓	✓
H120E S	✓	✓	✓	✓	✓	✓	✓	✓
H130E S	✓	✓	✓	✓	✓	✓	✓	✓

CW-30 S Dedicated Coupler (continued)

Undercarriage	Rear Blade							
Counterweight	3.7 mt				4.2 mt			
Boom Type	1 PC		VA		1 PC		VA	
Stick Length	2.50 m (8'2")	2.80 m (9'2")	2.50 m (8'2")	2.80 m (9'2")	2.50 m (8'2")	2.80 m (9'2")	2.50 m (8'2")	2.80 m (9'2")
H115E S	✓	✓	✓	✓	✓	✓	✓	✓
H120 GC S					✓*	✓*	✓*	
H120E S	✓*	✓*	✓*		✓	✓	✓	✓
H130E S								

CW-30 S Dedicated Coupler (continued)

Undercarriage	Rear Blade (Wide U/C)							
Counterweight	3.7 mt				4.2 mt			
Boom Type	1 PC		VA		1 PC		VA	
Stick Length	2.50 m (8'2")	2.80 m (9'2")	2.50 m (8'2")	2.80 m (9'2")	2.50 m (8'2")	2.80 m (9'2")	2.50 m (8'2")	2.80 m (9'2")
H115E S	✓	✓	✓	✓	✓	✓	✓	✓
H120 GC S	✓	✓*	✓*		✓	✓	✓	✓
H120E S	✓	✓	✓	✓	✓	✓	✓	✓
H130E S	✓*				✓	✓*	✓	

CW-30 Dedicated Coupler

Undercarriage	Front and Rear Outriggers							
Counterweight	3.7 mt				4.2 mt			
Boom Type	1 PC		VA		1 PC		VA	
Stick Length	2.50 m (8'2")	2.80 m (9'2")	2.50 m (8'2")	2.80 m (9'2")	2.50 m (8'2")	2.80 m (9'2")	2.50 m (8'2")	2.80 m (9'2")
H115E S	✓	✓	✓	✓	✓	✓	✓	✓
H120 GC S	✓	✓	✓	✓	✓	✓	✓	✓
H120E S	✓	✓	✓	✓	✓	✓	✓	✓
H130E S	✓	✓	✓	✓	✓	✓	✓	✓

CW-30 Dedicated Coupler (continued)

Undercarriage	Front Outriggers; Rear Blade (Wide U/C)							
Counterweight	3.7 mt				4.2 mt			
Boom Type	1 PC		VA		1 PC		VA	
Stick Length	2.50 m (8'2")	2.80 m (9'2")	2.50 m (8'2")	2.80 m (9'2")	2.50 m (8'2")	2.80 m (9'2")	2.50 m (8'2")	2.80 m (9'2")
H115E S	✓	✓	✓	✓	✓	✓	✓	✓
H120 GC S	✓	✓	✓	✓	✓	✓	✓	✓
H120E S	✓	✓	✓	✓	✓	✓	✓	✓
H130E S	✓	✓	✓		✓	✓	✓	

(continued on next page)

Matching – Wheeled Excavators (continued)

Match
 Working Range Front Only
 Allowed Usage on Machine Less Than 50%
 No Match

M320F (continued)

CW-30 Dedicated Coupler (continued)

Undercarriage	Front Outriggers; Rear Blade							
Counterweight	3.7 mt				4.2 mt			
Boom Type	1 PC		VA		1 PC		VA	
Stick Length	2.50 m (8'2")	2.80 m (9'2")	2.50 m (8'2")	2.80 m (9'2")	2.50 m (8'2")	2.80 m (9'2")	2.50 m (8'2")	2.80 m (9'2")
H115E S	✓	✓	✓	✓	✓	✓	✓	✓
H120 GC S	✓	✓	✓	✓	✓	✓	✓	✓
H120E S	✓	✓	✓	✓	✓	✓	✓	✓
H130E S	✓	✓	✓	✓	✓	✓	✓	✓

CW-30 Dedicated Coupler (continued)

Undercarriage	Rear Blade							
Counterweight	3.7 mt				4.2 mt			
Boom Type	1 PC		VA		1 PC		VA	
Stick Length	2.50 m (8'2")	2.80 m (9'2")	2.50 m (8'2")	2.80 m (9'2")	2.50 m (8'2")	2.80 m (9'2")	2.50 m (8'2")	2.80 m (9'2")
H115E S	✓	✓	✓	✓	✓	✓	✓	✓
H120 GC S					✓	✓*	✓*	✓*
H120E S	✓*	✓*	✓*		✓	✓	✓	✓*
H130E S								

CW-30 Dedicated Coupler (continued)

Undercarriage	Rear Blade (Wide U/C)							
Counterweight	3.7 mt				4.2 mt			
Boom Type	1 PC		VA		1 PC		VA	
Stick Length	2.50 m (8'2")	2.80 m (9'2")	2.50 m (8'2")	2.80 m (9'2")	2.50 m (8'2")	2.80 m (9'2")	2.50 m (8'2")	2.80 m (9'2")
H115E S	✓	✓	✓	✓	✓	✓	✓	✓
H120 GC S	✓	✓*	✓	✓*	✓	✓	✓	✓
H120E S	✓	✓	✓	✓	✓	✓	✓	✓
H130E S	✓*				✓	✓*	✓	

M322D2

Pin-on

Undercarriage	Front and Rear Outriggers					
Counterweight	3.9 mt					
Boom Type	1 PC			VA		
Stick Length	2.20 m (7'3")	2.50 m (8'2")	2.90 m (9'6")	2.20 m (7'3")	2.50 m (8'2")	2.90 m (9'6")
H115E S	✓	✓	✓	✓	✓	✓
H120 GC	✓	✓	✓	✓	✓	✓
H120 GC Side-mount	✓	✓	✓	✓	✓	✓
H120 GC S	✓	✓	✓	✓	✓	✓
H120E S	✓	✓	✓	✓	✓	✓
H130E S	✓	✓		✓	✓	

(continued on next page)

Hammer Technical Specifications

Matching – Wheeled Excavators (continued)

Match
 Working Range Front Only
 Allowed Usage on Machine Less Than 50%
 No Match

M322D2 (continued)

Pin-on (continued)

Undercarriage	Front and Rear Outriggers					
Counterweight	4.4 mt					
Boom Type	1 PC			VA		
Stick Length	2.20 m (7'3")	2.50 m (8'2")	2.90 m (9'6")	2.20 m (7'3")	2.50 m (8'2")	2.90 m (9'6")
H115E S	✓	✓	✓	✓	✓	✓
H120 GC	✓	✓	✓	✓	✓	✓
H120 GC Side-mount	✓	✓	✓	✓	✓	✓
H120 GC S	✓	✓	✓	✓	✓	✓
H120E S	✓	✓	✓	✓	✓	✓
H130E S	✓	✓		✓	✓	

Pin-on (continued)

Undercarriage	Front and Rear Outriggers					
Counterweight	5.4 mt					
Boom Type	1 PC			VA		
Stick Length	2.20 m (7'3")	2.50 m (8'2")	2.90 m (9'6")	2.20 m (7'3")	2.50 m (8'2")	2.90 m (9'6")
H115E S	✓	✓	✓	✓	✓	✓
H120 GC	✓	✓	✓	✓	✓	✓
H120 GC Side-mount	✓	✓	✓	✓	✓	✓
H120 GC S	✓	✓	✓	✓	✓	✓
H120E S	✓	✓	✓	✓	✓	✓
H130E S	✓	✓		✓	✓	

Pin-on (continued)

Undercarriage	Front Outriggers; Rear Blade					
Counterweight	3.9 mt					
Boom Type	1 PC			VA		
Stick Length	2.20 m (7'3")	2.50 m (8'2")	2.90 m (9'6")	2.20 m (7'3")	2.50 m (8'2")	2.90 m (9'6")
H115E S	✓	✓	✓	✓	✓	✓
H120 GC	✓	✓	✓	✓	✓	✓
H120 GC Side-mount	✓	✓	✓	✓	✓	✓
H120 GC S	✓	✓	✓	✓	✓	✓
H120E S	✓	✓	✓	✓	✓	✓
H130E S	✓	✓		✓	✓	

Pin-on (continued)

Undercarriage	Front Outriggers; Rear Blade					
Counterweight	4.4 mt					
Boom Type	1 PC			VA		
Stick Length	2.20 m (7'3")	2.50 m (8'2")	2.90 m (9'6")	2.20 m (7'3")	2.50 m (8'2")	2.90 m (9'6")
H115E S	✓	✓	✓	✓	✓	✓
H120 GC	✓	✓	✓	✓	✓	✓
H120 GC Side-mount	✓	✓	✓	✓	✓	✓
H120 GC S	✓	✓	✓	✓	✓	✓
H120E S	✓	✓	✓	✓	✓	✓
H130E S	✓	✓		✓	✓	

(continued on next page)

Matching – Wheeled Excavators (continued)

Match
 Working Range Front Only
 Allowed Usage on Machine Less Than 50%
 No Match

M322D2 (continued)

Pin-on (continued)

Undercarriage	Front Outriggers; Rear Blade					
Counterweight	5.4 mt					
Boom Type	1 PC			VA		
Stick Length	2.20 m (7'3")	2.50 m (8'2")	2.90 m (9'6")	2.20 m (7'3")	2.50 m (8'2")	2.90 m (9'6")
H115E S	✓	✓	✓	✓	✓	✓
H120 GC	✓	✓	✓	✓	✓	✓
H120 GC Side-mount	✓	✓	✓	✓	✓	✓
H120 GC S	✓	✓	✓	✓	✓	✓
H120E S	✓	✓	✓	✓	✓	✓
H130E S	✓	✓		✓	✓	

Pin-on (continued)

Undercarriage	Rear Blade					
Counterweight	3.9 mt					
Boom Type	1 PC			VA		
Stick Length	2.20 m (7'3")	2.50 m (8'2")	2.90 m (9'6")	2.20 m (7'3")	2.50 m (8'2")	2.90 m (9'6")
H115E S	✓	✓	✓	✓	✓	✓
H120 GC	✓	✓		✓	✓	
H120 GC Side-mount	✓	✓	✓	✓	✓	✓
H120 GC S	✓	✓	✓*	✓	✓	✓*
H120E S	✓	✓	✓	✓	✓	✓
H130E S	✓	✓*		✓	✓*	

Pin-on (continued)

Undercarriage	Rear Blade					
Counterweight	4.4 mt					
Boom Type	1 PC			VA		
Stick Length	2.20 m (7'3")	2.50 m (8'2")	2.90 m (9'6")	2.20 m (7'3")	2.50 m (8'2")	2.90 m (9'6")
H115E S	✓	✓	✓	✓	✓	✓
H120 GC	✓	✓	✓	✓	✓	✓
H120 GC Side-mount	✓	✓	✓	✓	✓	✓
H120 GC S	✓	✓	✓	✓	✓	✓
H120E S	✓	✓	✓	✓	✓	✓
H130E S	✓	✓		✓	✓	

Pin-on (continued)

Undercarriage	Rear Blade					
Counterweight	5.4 mt					
Boom Type	1 PC			VA		
Stick Length	2.20 m (7'3")	2.50 m (8'2")	2.90 m (9'6")	2.20 m (7'3")	2.50 m (8'2")	2.90 m (9'6")
H115E S	✓	✓	✓	✓	✓	✓
H120 GC	✓	✓	✓	✓	✓	✓
H120 GC Side-mount	✓	✓	✓	✓	✓	✓
H120 GC S	✓	✓	✓	✓	✓	✓
H120E S	✓	✓	✓	✓	✓	✓
H130E S	✓	✓		✓	✓	

(continued on next page)

Hammer Technical Specifications

Matching – Wheeled Excavators (continued)

Match
 Working Range Front Only
 Allowed Usage on Machine Less Than 50%
 No Match

M322D2 (continued)

Cat Pin Grabber Coupler

Undercarriage	Front and Rear Outriggers					
Counterweight	3.9 mt					
Boom Type	1 PC			VA		
Stick Length	2.20 m (7'3")	2.50 m (8'2")	2.90 m (9'6")	2.20 m (7'3")	2.50 m (8'2")	2.90 m (9'6")
H115E S	✓	✓	✓	✓	✓	✓
H120 GC	✓	✓		✓	✓	
H120 GC Side-mount	✓	✓	✓	✓	✓	✓
H120 GC S	✓	✓		✓	✓	
H120E S	✓	✓	✓	✓	✓	✓
H130E S	✓	✓		✓	✓	

Cat Pin Grabber Coupler (continued)

Undercarriage	Front and Rear Outriggers					
Counterweight	4.4 mt					
Boom Type	1 PC			VA		
Stick Length	2.20 m (7'3")	2.50 m (8'2")	2.90 m (9'6")	2.20 m (7'3")	2.50 m (8'2")	2.90 m (9'6")
H115E S	✓	✓	✓	✓	✓	✓
H120 GC	✓	✓		✓	✓	
H120 GC Side-mount	✓	✓	✓	✓	✓	✓
H120 GC S	✓	✓		✓	✓	
H120E S	✓	✓	✓	✓	✓	✓
H130E S	✓	✓		✓	✓	

Cat Pin Grabber Coupler (continued)

Undercarriage	Front and Rear Outriggers					
Counterweight	5.4 mt					
Boom Type	1 PC			VA		
Stick Length	2.20 m (7'3")	2.50 m (8'2")	2.90 m (9'6")	2.20 m (7'3")	2.50 m (8'2")	2.90 m (9'6")
H115E S	✓	✓	✓	✓	✓	✓
H120 GC	✓	✓		✓	✓	
H120 GC Side-mount	✓	✓	✓	✓	✓	✓
H120 GC S	✓	✓		✓	✓	
H120E S	✓	✓	✓	✓	✓	✓
H130E S	✓	✓		✓	✓	

Cat Pin Grabber Coupler (continued)

Undercarriage	Front Outriggers; Rear Blade					
Counterweight	3.9 mt					
Boom Type	1 PC			VA		
Stick Length	2.20 m (7'3")	2.50 m (8'2")	2.90 m (9'6")	2.20 m (7'3")	2.50 m (8'2")	2.90 m (9'6")
H115E S	✓	✓	✓	✓	✓	✓
H120 GC	✓	✓		✓	✓	
H120 GC Side-mount	✓	✓	✓	✓	✓	✓
H120 GC S	✓	✓		✓	✓	
H120E S	✓	✓	✓	✓	✓	✓
H130E S	✓	✓		✓	✓	

(continued on next page)

Matching – Wheeled Excavators (continued)

Match
 Working Range Front Only
 Allowed Usage on Machine Less Than 50%
 No Match

M322D2 (continued)

Cat Pin Grabber Coupler (continued)

Undercarriage	Front Outriggers; Rear Blade					
Counterweight	4.4 mt					
Boom Type	1 PC			VA		
Stick Length	2.20 m (7'3")	2.50 m (8'2")	2.90 m (9'6")	2.20 m (7'3")	2.50 m (8'2")	2.90 m (9'6")
H115E S	✓	✓	✓	✓	✓	✓
H120 GC	✓	✓		✓	✓	
H120 GC Side-mount	✓	✓	✓	✓	✓	✓
H120 GC S	✓	✓		✓	✓	
H120E S	✓	✓	✓	✓	✓	✓
H130E S	✓	✓		✓	✓	

Cat Pin Grabber Coupler (continued)

Undercarriage	Front Outriggers; Rear Blade					
Counterweight	5.4 mt					
Boom Type	1 PC			VA		
Stick Length	2.20 m (7'3")	2.50 m (8'2")	2.90 m (9'6")	2.20 m (7'3")	2.50 m (8'2")	2.90 m (9'6")
H115E S	✓	✓	✓	✓	✓	✓
H120 GC	✓	✓		✓	✓	
H120 GC Side-mount	✓	✓	✓	✓	✓	✓
H120 GC S	✓	✓		✓	✓	
H120E S	✓	✓	✓	✓	✓	✓
H130E S	✓	✓		✓	✓	

Cat Pin Grabber Coupler (continued)

Undercarriage	Rear Blade					
Counterweight	3.9 mt					
Boom Type	1 PC			VA		
Stick Length	2.20 m (7'3")	2.50 m (8'2")	2.90 m (9'6")	2.20 m (7'3")	2.50 m (8'2")	2.90 m (9'6")
H115E S	✓	✓	✓	✓	✓	✓
H120 GC						
H120 GC Side-mount				✓*		
H120 GC S						
H120E S	✓*			✓*	✓*	
H130E S						

Cat Pin Grabber Coupler (continued)

Undercarriage	Rear Blade					
Counterweight	4.4 mt					
Boom Type	1 PC			VA		
Stick Length	2.20 m (7'3")	2.50 m (8'2")	2.90 m (9'6")	2.20 m (7'3")	2.50 m (8'2")	2.90 m (9'6")
H115E S	✓	✓	✓	✓	✓	✓
H120 GC	✓*			✓*		
H120 GC Side-mount	✓	✓*		✓	✓*	
H120 GC S	✓*	✓*		✓*	✓*	
H120E S	✓	✓	✓*	✓	✓	✓*
H130E S						

(continued on next page)

Hammer Technical Specifications

Matching – Wheeled Excavators *(continued)*

Match
 * Working Range Front Only
 † Allowed Usage on Machine Less Than 50%
 No Match

M322D2 *(continued)*

Cat Pin Grabber Coupler *(continued)*

Undercarriage	Rear Blade					
Counterweight	5.4 mt					
Boom Type	1 PC			VA		
Stick Length	2.20 m (7'3")	2.50 m (8'2")	2.90 m (9'6")	2.20 m (7'3")	2.50 m (8'2")	2.90 m (9'6")
H115E S	✓	✓	✓	✓	✓	✓
H120 GC	✓	✓		✓	✓	
H120 GC Side-mount	✓	✓	✓	✓	✓	✓
H120 GC S	✓	✓		✓	✓	
H120E S	✓	✓	✓	✓	✓	✓
H130E S	✓	✓		✓	✓	

CW-40 S Dedicated Coupler

Undercarriage	Front and Rear Outriggers					
Counterweight	3.9 mt					
Boom Type	1 PC			VA		
Stick Length	2.20 m (7'3")	2.50 m (8'2")	2.90 m (9'6")	2.20 m (7'3")	2.50 m (8'2")	2.90 m (9'6")
H115E S	✓	✓	✓	✓	✓	✓
H120 GC	✓	✓		✓	✓	
H120 GC S	✓	✓	✓	✓	✓	✓
H120E S	✓	✓		✓	✓	
H130E S	✓			✓		

CW-40 S Dedicated Coupler *(continued)*

Undercarriage	Front and Rear Outriggers					
Counterweight	4.4 mt					
Boom Type	1 PC			VA		
Stick Length	2.20 m (7'3")	2.50 m (8'2")	2.90 m (9'6")	2.20 m (7'3")	2.50 m (8'2")	2.90 m (9'6")
H115E S	✓	✓	✓	✓	✓	✓
H120 GC	✓	✓		✓	✓	
H120 GC S	✓	✓	✓	✓	✓	✓
H120E S	✓	✓		✓	✓	
H130E S	✓			✓		

CW-40 S Dedicated Coupler *(continued)*

Undercarriage	Front and Rear Outriggers					
Counterweight	5.4 mt					
Boom Type	1 PC			VA		
Stick Length	2.20 m (7'3")	2.50 m (8'2")	2.90 m (9'6")	2.20 m (7'3")	2.50 m (8'2")	2.90 m (9'6")
H115E S	✓	✓	✓	✓	✓	✓
H120 GC	✓	✓		✓	✓	
H120 GC S	✓	✓	✓	✓	✓	✓
H120E S	✓	✓		✓	✓	
H130E S	✓			✓		

(continued on next page)

Matching – Wheeled Excavators (continued)

Match
 Working Range Front Only
 Allowed Usage on Machine Less Than 50%
 No Match

M322D2 (continued)

CW-40 S Dedicated Coupler (continued)

Undercarriage	Front Outriggers; Rear Blade					
Counterweight	3.9 mt					
Boom Type	1 PC			VA		
Stick Length	2.20 m (7'3")	2.50 m (8'2")	2.90 m (9'6")	2.20 m (7'3")	2.50 m (8'2")	2.90 m (9'6")
H115E S	✓	✓	✓	✓	✓	✓
H120 GC	✓	✓		✓	✓	
H120 GC S	✓	✓	✓	✓	✓	✓
H120E S	✓	✓		✓	✓	
H130E S	✓			✓		

CW-40 S Dedicated Coupler (continued)

Undercarriage	Front Outriggers; Rear Blade					
Counterweight	4.4 mt					
Boom Type	1 PC			VA		
Stick Length	2.20 m (7'3")	2.50 m (8'2")	2.90 m (9'6")	2.20 m (7'3")	2.50 m (8'2")	2.90 m (9'6")
H115E S	✓	✓	✓	✓	✓	✓
H120 GC	✓	✓		✓	✓	
H120 GC S	✓	✓	✓	✓	✓	✓
H120E S	✓	✓		✓	✓	
H130E S	✓			✓		

CW-40 S Dedicated Coupler (continued)

Undercarriage	Front Outriggers; Rear Blade					
Counterweight	5.4 mt					
Boom Type	1 PC			VA		
Stick Length	2.20 m (7'3")	2.50 m (8'2")	2.90 m (9'6")	2.20 m (7'3")	2.50 m (8'2")	2.90 m (9'6")
H115E S	✓	✓	✓	✓	✓	✓
H120 GC	✓	✓		✓	✓	
H120 GC S	✓	✓	✓	✓	✓	✓
H120E S	✓	✓		✓	✓	
H130E S	✓			✓		

CW-40 S Dedicated Coupler (continued)

Undercarriage	Rear Blade					
Counterweight	3.9 mt					
Boom Type	1 PC			VA		
Stick Length	2.20 m (7'3")	2.50 m (8'2")	2.90 m (9'6")	2.20 m (7'3")	2.50 m (8'2")	2.90 m (9'6")
H115E S	✓	✓	✓	✓	✓	✓
H120 GC						
H120 GC S	✓*			✓*		
H120E S	✓	✓		✓	✓	
H130E S						

(continued on next page)

Hammer Technical Specifications

Matching – Wheeled Excavators (continued)

 Match

 * Working Range Front Only

 † Allowed Usage on Machine Less Than 50%

 No Match

M322D2 (continued)

CW-40 S Dedicated Coupler (continued)

Undercarriage	Rear Blade					
Counterweight	4.4 mt					
Boom Type	1 PC			VA		
Stick Length	2.20 m (7'3")	2.50 m (8'2")	2.90 m (9'6")	2.20 m (7'3")	2.50 m (8'2")	2.90 m (9'6")
H115E S	✓	✓	✓	✓	✓	✓
H120 GC	✓	✓*		✓	✓*	
H120 GC S	✓	✓		✓	✓	
H120E S	✓	✓		✓	✓	
H130E S	✓*			✓*		

CW-40 S Dedicated Coupler (continued)

Undercarriage	Rear Blade					
Counterweight	5.4 mt					
Boom Type	1 PC			VA		
Stick Length	2.20 m (7'3")	2.50 m (8'2")	2.90 m (9'6")	2.20 m (7'3")	2.50 m (8'2")	2.90 m (9'6")
H115E S	✓	✓	✓	✓	✓	✓
H120 GC	✓	✓		✓	✓	
H120 GC S	✓	✓	✓	✓	✓	✓
H120E S	✓	✓		✓	✓	
H130E S	✓			✓		

CW-40 Dedicated Coupler

Undercarriage	Front and Rear Outriggers					
Counterweight	3.9 mt					
Boom Type	1 PC			VA		
Stick Length	2.20 m (7'3")	2.50 m (8'2")	2.90 m (9'6")	2.20 m (7'3")	2.50 m (8'2")	2.90 m (9'6")
H115E S	✓	✓	✓	✓	✓	✓
H120 GC	✓	✓	✓	✓	✓	
H120 GC S	✓	✓	✓	✓	✓	✓
H120E S	✓	✓		✓	✓	
H130E S	✓			✓		

CW-40 Dedicated Coupler (continued)

Undercarriage	Front and Rear Outriggers					
Counterweight	4.4 mt					
Boom Type	1 PC			VA		
Stick Length	2.20 m (7'3")	2.50 m (8'2")	2.90 m (9'6")	2.20 m (7'3")	2.50 m (8'2")	2.90 m (9'6")
H115E S	✓	✓	✓	✓	✓	✓
H120 GC	✓	✓	✓	✓	✓	
H120 GC S	✓	✓	✓	✓	✓	✓
H120E S	✓	✓		✓	✓	
H130E S	✓			✓		

(continued on next page)

Matching – Wheeled Excavators (continued)

Match
 Working Range Front Only
 Allowed Usage on Machine Less Than 50%
 No Match

M322D2 (continued)

CW-40 Dedicated Coupler (continued)

Undercarriage	Front and Rear Outriggers					
Counterweight	5.4 mt					
Boom Type	1 PC			VA		
Stick Length	2.20 m (7'3")	2.50 m (8'2")	2.90 m (9'6")	2.20 m (7'3")	2.50 m (8'2")	2.90 m (9'6")
H115E S	✓	✓	✓	✓	✓	✓
H120 GC	✓	✓	✓	✓	✓	
H120 GC S	✓	✓	✓	✓	✓	✓
H120E S	✓	✓		✓	✓	
H130E S	✓			✓		

CW-40 Dedicated Coupler (continued)

Undercarriage	Front Outriggers; Rear Blade					
Counterweight	3.9 mt					
Boom Type	1 PC			VA		
Stick Length	2.20 m (7'3")	2.50 m (8'2")	2.90 m (9'6")	2.20 m (7'3")	2.50 m (8'2")	2.90 m (9'6")
H115E S	✓	✓	✓	✓	✓	✓
H120 GC	✓	✓	✓	✓	✓	
H120 GC S	✓	✓	✓	✓	✓	✓
H120E S	✓	✓		✓	✓	
H130E S	✓			✓		

CW-40 Dedicated Coupler (continued)

Undercarriage	Front Outriggers; Rear Blade					
Counterweight	4.4 mt					
Boom Type	1 PC			VA		
Stick Length	2.20 m (7'3")	2.50 m (8'2")	2.90 m (9'6")	2.20 m (7'3")	2.50 m (8'2")	2.90 m (9'6")
H115E S	✓	✓	✓	✓	✓	✓
H120 GC	✓	✓	✓	✓	✓	
H120 GC S	✓	✓	✓	✓	✓	✓
H120E S	✓	✓		✓	✓	
H130E S	✓			✓		

CW-40 Dedicated Coupler (continued)

Undercarriage	Front Outriggers; Rear Blade					
Counterweight	5.4 mt					
Boom Type	1 PC			VA		
Stick Length	2.20 m (7'3")	2.50 m (8'2")	2.90 m (9'6")	2.20 m (7'3")	2.50 m (8'2")	2.90 m (9'6")
H115E S	✓	✓	✓	✓	✓	✓
H120 GC	✓	✓	✓	✓	✓	
H120 GC S	✓	✓	✓	✓	✓	✓
H120E S	✓	✓		✓	✓	
H130E S	✓			✓		

(continued on next page)

Hammer Technical Specifications

Matching – Wheeled Excavators (continued)

Match
 * Working Range Front Only
 † Allowed Usage on Machine Less Than 50%
 No Match

M322D2 (continued)

CW-40 Dedicated Coupler (continued)

Undercarriage	Rear Blade					
Counterweight	3.9 mt					
Boom Type	1 PC			VA		
Stick Length	2.20 m (7'3")	2.50 m (8'2")	2.90 m (9'6")	2.20 m (7'3")	2.50 m (8'2")	2.90 m (9'6")
H115E S	✓	✓	✓	✓	✓	✓
H120 GC	✓*			✓*		
H120 GC S	✓*	✓*		✓*	✓*	
H120E S	✓	✓*		✓	✓	
H130E S						

CW-40 Dedicated Coupler (continued)

Undercarriage	Rear Blade					
Counterweight	4.4 mt					
Boom Type	1 PC			VA		
Stick Length	2.20 m (7'3")	2.50 m (8'2")	2.90 m (9'6")	2.20 m (7'3")	2.50 m (8'2")	2.90 m (9'6")
H115E S	✓	✓	✓	✓	✓	✓
H120 GC	✓	✓*		✓	✓*	
H120 GC S	✓	✓	✓*	✓	✓	✓*
H120E S	✓	✓		✓	✓	
H130E S	✓*			✓*		

CW-40 Dedicated Coupler (continued)

Undercarriage	Rear Blade					
Counterweight	5.4 mt					
Boom Type	1 PC			VA		
Stick Length	2.20 m (7'3")	2.50 m (8'2")	2.90 m (9'6")	2.20 m (7'3")	2.50 m (8'2")	2.90 m (9'6")
H115E S	✓	✓	✓	✓	✓	✓
H120 GC	✓	✓	✓	✓	✓	
H120 GC S	✓	✓	✓	✓	✓	✓
H120E S	✓	✓		✓	✓	
H130E S	✓			✓		

M322F

Pin-on

Undercarriage	Front and Rear Outriggers							
Counterweight	3.5 mt				4.7 mt			
Boom Type	1 PC		VA		1 PC		VA	
Stick Length	2.50 m (8'2")	2.90 m (9'6")	2.50 m (8'2")	2.90 m (9'6")	2.50 m (8'2")	2.90 m (9'6")	2.50 m (8'2")	2.90 m (9'6")
H115E S	✓	✓	✓	✓	✓	✓	✓	✓
H120 GC	✓	✓	✓	✓	✓	✓	✓	✓
H120 GC S	✓	✓	✓	✓	✓	✓	✓	✓
H120E S	✓	✓	✓	✓	✓	✓	✓	✓
H130E S	✓	✓	✓	✓	✓	✓	✓	✓

(continued on next page)

Hammer Technical Specifications

Matching – Wheeled Excavators (continued)

Match
 Working Range Front Only
 Allowed Usage on Machine Less Than 50%
 No Match

M322F (continued)

Pin-on (continued)

Undercarriage	Front Blade; Rear Outriggers							
Counterweight	3.5 mt				4.7 mt			
Boom Type	1 PC		VA		1 PC		VA	
Stick Length	2.50 m (8'2")	2.90 m (9'6")	2.50 m (8'2")	2.90 m (9'6")	2.50 m (8'2")	2.90 m (9'6")	2.50 m (8'2")	2.90 m (9'6")
H115E S	✓	✓	✓	✓	✓	✓	✓	✓
H120 GC	✓	✓	✓	✓	✓	✓	✓	✓
H120 GC S	✓	✓	✓	✓	✓	✓	✓	✓
H120E S	✓	✓	✓	✓	✓	✓	✓	✓
H130E S	✓	✓	✓	✓	✓	✓	✓	✓

Pin-on (continued)

Undercarriage	Front Outriggers; Rear Blade							
Counterweight	3.5 mt				4.7 mt			
Boom Type	1 PC		VA		1 PC		VA	
Stick Length	2.50 m (8'2")	2.90 m (9'6")	2.50 m (8'2")	2.90 m (9'6")	2.50 m (8'2")	2.90 m (9'6")	2.50 m (8'2")	2.90 m (9'6")
H115E S	✓	✓	✓	✓	✓	✓	✓	✓
H120 GC	✓	✓	✓	✓	✓	✓	✓	✓
H120 GC S	✓	✓	✓	✓	✓	✓	✓	✓
H120E S	✓	✓	✓	✓	✓	✓	✓	✓
H130E S	✓	✓	✓	✓	✓	✓	✓	✓

Pin-on (continued)

Undercarriage	Rear Blade							
Counterweight	3.5 mt				4.7 mt			
Boom Type	1 PC		VA		1 PC		VA	
Stick Length	2.50 m (8'2")	2.90 m (9'6")	2.50 m (8'2")	2.90 m (9'6")	2.50 m (8'2")	2.90 m (9'6")	2.50 m (8'2")	2.90 m (9'6")
H115E S	✓	✓	✓	✓	✓	✓	✓	✓
H120 GC	✓	✓*	✓	✓	✓	✓	✓	✓
H120 GC S	✓	✓*	✓	✓*	✓	✓	✓	✓
H120E S	✓	✓	✓	✓	✓	✓	✓	✓
H130E S	✓	✓	✓*	✓	✓	✓	✓	✓

Cat Pin Grabber Coupler

Undercarriage	Front and Rear Outriggers							
Counterweight	3.5 mt				4.7 mt			
Boom Type	1 PC		VA		1 PC		VA	
Stick Length	2.50 m (8'2")	2.90 m (9'6")	2.50 m (8'2")	2.90 m (9'6")	2.50 m (8'2")	2.90 m (9'6")	2.50 m (8'2")	2.90 m (9'6")
H115E S	✓	✓	✓	✓	✓	✓	✓	✓
H120 GC	✓	✓	✓	✓	✓	✓	✓	✓
H120 GC S	✓	✓	✓	✓	✓	✓	✓	✓
H120E S	✓	✓	✓	✓	✓	✓	✓	✓
H130E S	✓	✓	✓	✓	✓	✓	✓	✓

(continued on next page)

Hammer Technical Specifications

Matching – Wheeled Excavators (continued)

Match
 * Working Range Front Only
 † Allowed Usage on Machine Less Than 50%
 No Match

M322F (continued)

Cat Pin Grabber Coupler (continued)

Undercarriage	Front Blade; Rear Outriggers							
Counterweight	3.5 mt				4.7 mt			
Boom Type	1 PC		VA		1 PC		VA	
Stick Length	2.50 m (8'2")	2.90 m (9'6")	2.50 m (8'2")	2.90 m (9'6")	2.50 m (8'2")	2.90 m (9'6")	2.50 m (8'2")	2.90 m (9'6")
H115E S	✓	✓	✓	✓	✓	✓	✓	✓
H120 GC	✓		✓		✓		✓	
H120 GC S	✓		✓		✓		✓	
H120E S	✓	✓	✓	✓	✓	✓	✓	✓
H130E S	✓		✓		✓		✓	

Cat Pin Grabber Coupler (continued)

Undercarriage	Front Blade; Rear Outriggers							
Counterweight	3.5 mt				4.7 mt			
Boom Type	1 PC		VA		1 PC		VA	
Stick Length	2.50 m (8'2")	2.90 m (9'6")	2.50 m (8'2")	2.90 m (9'6")	2.50 m (8'2")	2.90 m (9'6")	2.50 m (8'2")	2.90 m (9'6")
H115E S	✓	✓	✓	✓	✓	✓	✓	✓
H120 GC	✓		✓		✓		✓	
H120 GC S	✓		✓		✓		✓	
H120E S	✓	✓	✓	✓	✓	✓	✓	✓
H130E S	✓		✓		✓		✓	

Cat Pin Grabber Coupler (continued)

Undercarriage	Rear Blade							
Counterweight	3.5 mt				4.7 mt			
Boom Type	1 PC		VA		1 PC		VA	
Stick Length	2.50 m (8'2")	2.90 m (9'6")	2.50 m (8'2")	2.90 m (9'6")	2.50 m (8'2")	2.90 m (9'6")	2.50 m (8'2")	2.90 m (9'6")
H115E S	✓	✓	✓	✓	✓	✓	✓	✓
H120 GC					✓		✓	
H120 GC S					✓		✓	
H120E S	✓*		✓*		✓	✓	✓	✓
H130E S					✓		✓	

CW-40 S Dedicated Coupler

Undercarriage	Front and Rear Outriggers							
Counterweight	3.5 mt				4.7 mt			
Boom Type	1 PC		VA		1 PC		VA	
Stick Length	2.50 m (8'2")	2.90 m (9'6")	2.50 m (8'2")	2.90 m (9'6")	2.50 m (8'2")	2.90 m (9'6")	2.50 m (8'2")	2.90 m (9'6")
H115E S	✓	✓	✓	✓	✓	✓	✓	✓
H120 GC S	✓	✓	✓	✓	✓	✓	✓	✓
H120E S	✓	✓	✓	✓	✓	✓	✓	✓
H130E S	✓		✓		✓		✓	

(continued on next page)

Hammer Technical Specifications

Matching – Wheeled Excavators (continued)

Match
 Working Range Front Only
 Allowed Usage on Machine Less Than 50%
 No Match

M322F (continued)

CW-40 S Dedicated Coupler (continued)

Undercarriage	Front Blade; Rear Outriggers							
Counterweight	3.5 mt				4.7 mt			
Boom Type	1 PC		VA		1 PC		VA	
Stick Length	2.50 m (8'2")	2.90 m (9'6")	2.50 m (8'2")	2.90 m (9'6")	2.50 m (8'2")	2.90 m (9'6")	2.50 m (8'2")	2.90 m (9'6")
H115E S	✓	✓	✓	✓	✓	✓	✓	✓
H120 GC S	✓	✓	✓	✓	✓	✓	✓	✓
H120E S	✓	✓	✓	✓	✓	✓	✓	✓
H130E S	✓		✓		✓		✓	

CW-40 S Dedicated Coupler (continued)

Undercarriage	Front Blade; Rear Outriggers							
Counterweight	3.5 mt				4.7 mt			
Boom Type	1 PC		VA		1 PC		VA	
Stick Length	2.50 m (8'2")	2.90 m (9'6")	2.50 m (8'2")	2.90 m (9'6")	2.50 m (8'2")	2.90 m (9'6")	2.50 m (8'2")	2.90 m (9'6")
H115E S	✓	✓	✓	✓	✓	✓	✓	✓
H120 GC S	✓	✓	✓	✓	✓	✓	✓	✓
H120E S	✓	✓	✓	✓	✓	✓	✓	✓
H130E S	✓		✓		✓		✓	

CW-40 S Dedicated Coupler (continued)

Undercarriage	Rear Blade							
Counterweight	3.5 mt				4.7 mt			
Boom Type	1 PC		VA		1 PC		VA	
Stick Length	2.50 m (8'2")	2.90 m (9'6")	2.50 m (8'2")	2.90 m (9'6")	2.50 m (8'2")	2.90 m (9'6")	2.50 m (8'2")	2.90 m (9'6")
H115E S	✓	✓	✓	✓	✓	✓	✓	✓
H120 GC S	✓*				✓	✓	✓	✓
H120E S	✓	✓*	✓		✓	✓	✓	✓
H130E S					✓		✓	

CW-40 Dedicated Coupler

Undercarriage	Front and Rear Outriggers							
Counterweight	3.5 mt				4.7 mt			
Boom Type	1 PC		VA		1 PC		VA	
Stick Length	2.50 m (8'2")	2.90 m (9'6")	2.50 m (8'2")	2.90 m (9'6")	2.50 m (8'2")	2.90 m (9'6")	2.50 m (8'2")	2.90 m (9'6")
H115E S	✓	✓	✓	✓	✓	✓	✓	✓
H120 GC S	✓	✓	✓	✓	✓	✓	✓	✓
H120E S	✓	✓	✓	✓	✓	✓	✓	✓
H130E S	✓		✓		✓		✓	

(continued on next page)

Hammer Technical Specifications

Matching – Wheeled Excavators *(continued)*

Match
 Working Range Front Only
 Allowed Usage on Machine Less Than 50%
 No Match

M322F *(continued)*

CW-40 Dedicated Coupler *(continued)*

Undercarriage	Front Blade; Rear Outriggers							
Counterweight	3.5 mt				4.7 mt			
Boom Type	1 PC		VA		1 PC		VA	
Stick Length	2.50 m (8'2")	2.90 m (9'6")	2.50 m (8'2")	2.90 m (9'6")	2.50 m (8'2")	2.90 m (9'6")	2.50 m (8'2")	2.90 m (9'6")
H115E S	✓	✓	✓	✓	✓	✓	✓	✓
H120 GC S	✓	✓	✓	✓	✓	✓	✓	✓
H120E S	✓	✓	✓	✓	✓	✓	✓	✓
H130E S	✓		✓		✓		✓	

CW-40 Dedicated Coupler *(continued)*

Undercarriage	Front Outriggers; Rear Blade							
Counterweight	3.5 mt				4.7 mt			
Boom Type	1 PC		VA		1 PC		VA	
Stick Length	2.50 m (8'2")	2.90 m (9'6")	2.50 m (8'2")	2.90 m (9'6")	2.50 m (8'2")	2.90 m (9'6")	2.50 m (8'2")	2.90 m (9'6")
H115E S	✓	✓	✓	✓	✓	✓	✓	✓
H120 GC S	✓	✓	✓	✓	✓	✓	✓	✓
H120E S	✓	✓	✓	✓	✓	✓	✓	✓
H130E S	✓		✓		✓		✓	

CW-40 Dedicated Coupler *(continued)*

Undercarriage	Rear Blade							
Counterweight	3.5 mt				4.7 mt			
Boom Type	1 PC		VA		1 PC		VA	
Stick Length	2.50 m (8'2")	2.90 m (9'6")	2.50 m (8'2")	2.90 m (9'6")	2.50 m (8'2")	2.90 m (9'6")	2.50 m (8'2")	2.90 m (9'6")
H115E S	✓	✓	✓	✓	✓	✓	✓	✓
H120 GC S	✓*		✓*		✓	✓	✓	✓
H120E S	✓	✓*	✓		✓	✓	✓	✓
H130E S					✓		✓	

Additional Options

Model	Part No.	Rock Edges	Wear Package (factory-installed)	Wear Package, Dealer-install	Autolube Kit, Hammer-mount	Autolube Kit, Carrier-mount
H110 GC Top-mount	569-1808		No			
H110 GC Side-mount	565-5678		No			
	569-1810		No			
H110 GC S Top-mount	565-4611		No		550-0446	
H110E S Top-mount	355-3817	355-5839	No	367-0863	317-4203	152-3395
	385-0326	355-5839	No	367-0863	317-4203	152-3395
H115 GC Top-mount	417-8035		No			
H115 GC Side-mount	417-8088		No			
	417-8092		No			
H115 GC S Top-mount	536-3733		No		550-0446	
H115E S Top-mount	355-7065	355-5839	No	367-0863	317-4203	152-3395
	385-0328	355-5839	No	367-0863	317-4203	152-3395
H120 GC Top-mount	572-0372		No			
H120 GC Side-mount	572-0373		No			
	572-0374		No			
	572-0375		No			
H120 GC S Top-mount	536-3734		No		550-0446	
H120E S Top-mount	355-7061	355-5785	No	365-9541	317-4204	152-3395
	385-0329	355-5785	No	365-9541	317-4204	152-3395
H130 GC Top-mount	572-0384		No			
H130 GC Side-mount	572-0385		No			
	572-0386		No			
H130 GC S Top-mount	536-3735		No		550-0446	
H130E S Top-mount	355-7063	355-5785	No	365-9541	317-4204	152-3395
	385-0330	355-5785	No	365-9541	317-4204	152-3395
H140 GC Top-mount	572-0376		No			
H140 GC S Top-mount	536-3736		No		550-0446	
H140E S Top-mount	363-0738	369-9027	No	388-3071	317-4204	152-3395
	426-4892	369-9027	Yes	388-3071	317-4204	152-3395
	431-0575	369-9027	No	388-3071	317-4204	152-3395
	431-0581	369-9027	No	388-3071	317-4204	152-3395
H160E S Top-mount	366-5119	371-7113	No	388-3071	317-4206	152-3395
	426-4894	371-7113	Yes	388-3071	317-4206	152-3395
	431-0578	371-7113	No	388-3071	317-4206	152-3395
	431-0584	371-7113	No	388-3071	317-4206	152-3395
H180E S Top-mount	366-5168	371-7113	No	388-3071	317-4206	152-3395
	426-4896	371-7113	Yes	388-3071	317-4206	152-3395
	431-0580	371-7113	No	388-3071	317-4206	152-3395
	431-0589	371-7113	No	388-3071	317-4206	152-3395

Hammer Technical Specifications

Autolube

Autolube Kit, Hammer-mount	Part No.	317-4203	317-4204	317-4206
Supply Pressure minimum, hammer circuit	bar	90	90	90
	psi	1305	1305	1305
Supply Pressure maximum, hammer circuit	bar	250	250	250
	psi	3626	3626	3626
Flow Displacement, per minute	l	2	2	2
	gal	0.6	0.6	0.6
Operating Temperature, minimum	°C	0	0	0
	°F	31	31	31
Operating Temperature, maximum	°C	70	70	70
	°F	158	158	158
Grease Flow, factory default, per minute	cc	1.68	1.68	1.68
	in ³	0.11	0.11	0.11
Autolube, hammer-mount, grease	single	317-8491	317-8491	317-8491
	12-pack	317-8492	317-8492	317-8492
Autolube Kit, carrier-mount				152-3395
Autolube, carrier-mount, hammer paste, cartridge (400 g)				130-6951
Autolube, carrier-mount, hammer paste, pail (5 kg)				133-8807

For more complete information on Cat products, dealer services, and industry solutions, visit us on the web at www.cat.com

© 2019 Caterpillar
All rights reserved

Materials and specifications are subject to change without notice. Featured machines in photos may include additional equipment. See your Cat dealer for available options.

CAT, CATERPILLAR, LET'S DO THE WORK, their respective logos, "Caterpillar Yellow," the "Power Edge" and Cat "Modern Hex" trade dress as well as corporate and product identity used herein, are trademarks of Caterpillar and may not be used without permission.

GEJQ9376-01 (07-2019)
Replaces GEJQ9376
(Global)

