

1206D-E70TTA

Industrial Engine

UN ECE R96 Stage IIIA/Brazil MAR-1

186-225 kW/249-302 hp

The 6 cylinder option for the Perkins® 1200 Series, the 1206D gives you a complete power solution for UN ECE R96 Stage IIIA/Brazil MAR-1 emission standards. The choice of options, engine configurations and robust technology allows you to integrate the 1206 range into your equipment with minimum engineering.

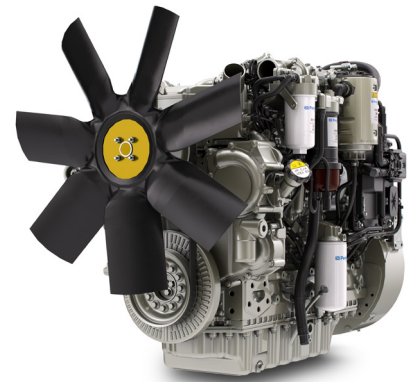

Features and Benefits

A lifetime of low cost

The engine's improved productivity and fuel consumption reduces the total cost of ownership.

Downsizing opportunity

The high power density and excellent torque in our 1206 range gives machine manufacturers the opportunity to use our 6 cylinder engine instead of a larger engine. Downsizing in this way can save you money and create more space to package new aftertreatment units. The 1206 range is an ideal engine solution for large and medium-sized machines for construction, agriculture, materials handling and general industrial applications.

Tailored for your machines

Your needs are our top priority, which is why we provide more tailored technology than anyone else. Working closely with OEMs, we have developed the 1206 range with hundreds of options so that it easily fits into your machine.

Specification	
Cylinders	6
Displacement litres (in ³)	7 (427.7)
Aspiration	Series turbocharged aftercooled
Bore and stroke mm (in)	105 x 135 (4.1 x 5.3)
Maximum power kW (hp)	225 (302)
Rated speed (rpm)	2200
Maximum torque Nm (lb ft) @ rpm	1274 (940) @ 1400
Combustion system	Direct injection
Weight kg (lb)	715 (1576)
Rotation (viewed from flywheel)	Anti-clockwise

For more information please contact a Perkins distributor: <http://distributorlocator.perkins.com>

All information in this document is substantially correct at time of printing and may be altered subsequently.
Photographs are for illustrative purposes only and may not reflect final specification.
Final weight and dimensions will depend on completed specification.
Information subject to selected configuration, and subject to change without notice.
Performance measured per ISO 14396:2002
PN3208/12/20 Produced in England ©2020 Perkins Engines Company Limited

 **Perkins®**

THE HEART OF EVERY GREAT MACHINE

1206D-E70TTA

Industrial Engine

UN ECE R96 Stage IIIA/Brazil MAR-1

186-225 kW/249-302 hp

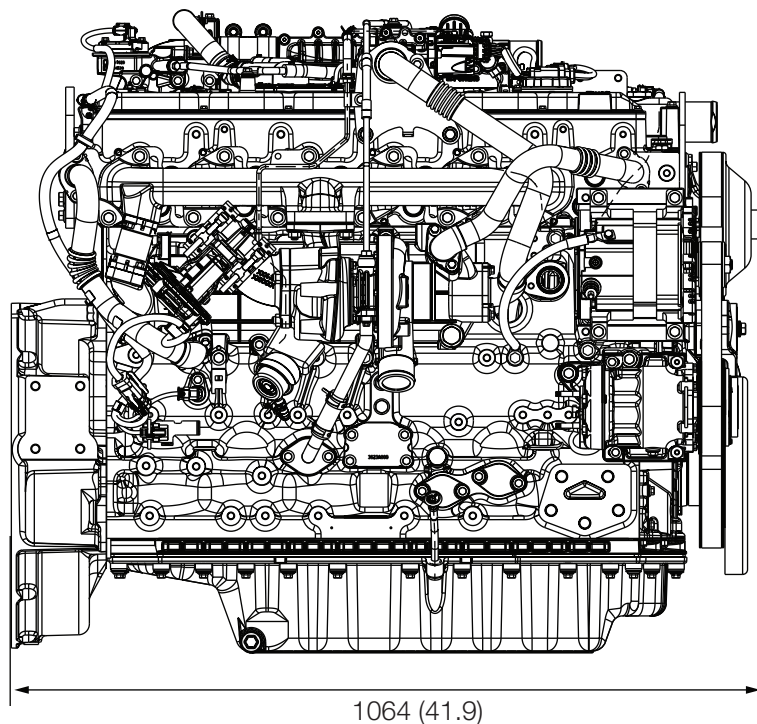
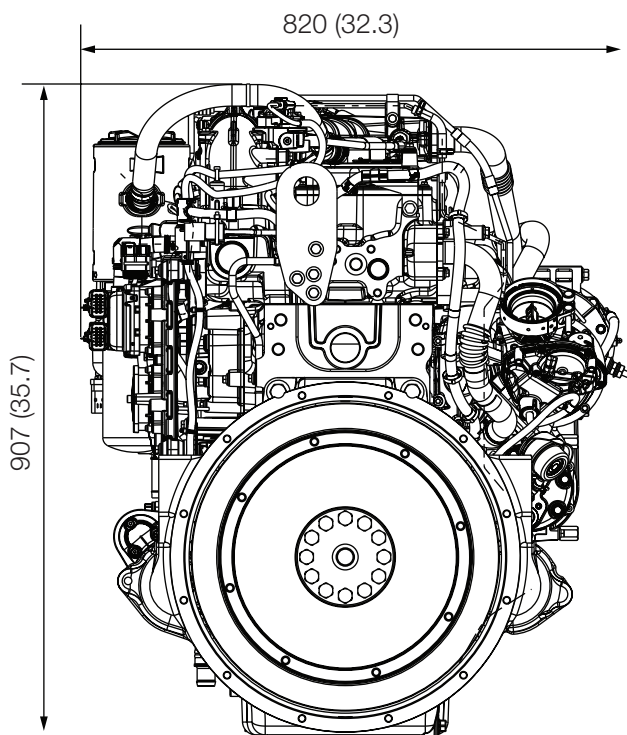
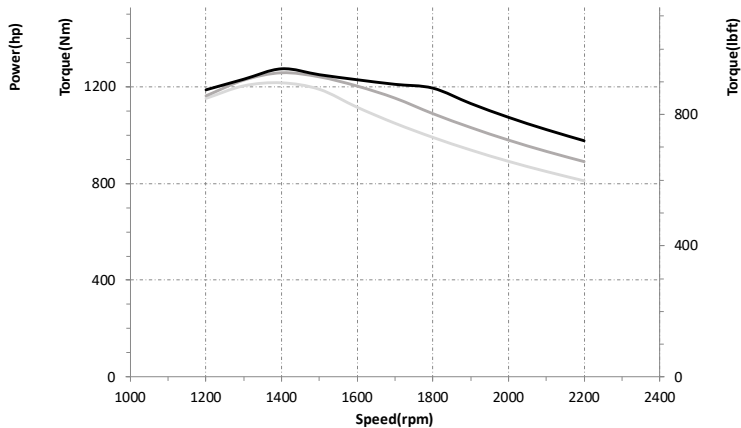
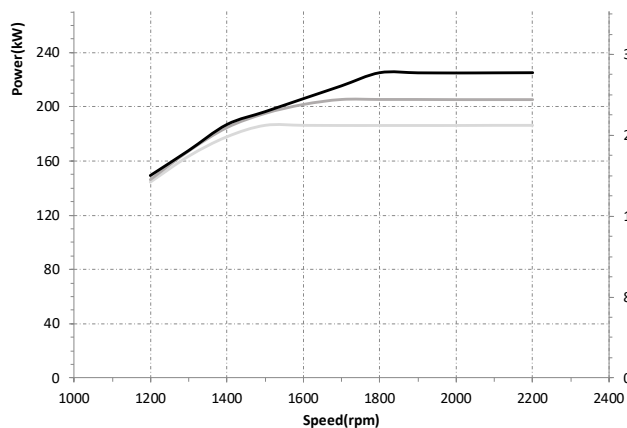

For more information please contact a Perkins distributor: <http://distributorlocator.perkins.com>

All information in this document is substantially correct at time of printing and may be altered subsequently.

Photographs are for illustrative purposes only and may not reflect final specification.

Final weight and dimensions will depend on completed specification.

Information subject to selected configuration, and subject to change without notice.

Performance measured per ISO 14396:2002

PN3208/12/20 Produced in England ©2020 Perkins Engines Company Limited

 **Perkins**[®]

THE HEART OF EVERY GREAT MACHINE