



Pallet and Construction Forks

for 950 GC and 950M-980M Wheel Loaders

Technical Specifications

Not all attachments are available in all regions. Consult your Cat® dealer for specific configurations available in your region.

Table of Contents

ITA Forks				2	
950 GC	2	962M	4	972M	6
950M	3	966M	5	980M	7
Construction Forks				8	
950 GC	8	962M	12	972M	16
950M	10	966M	14	980M	18
Pallet Forks				20	
950 GC	20	962M	22	972M	24
950M	21	966M	23	980M	25



WARNING: Do not exceed tine load capacity. Individual tine capacity is stamped on the side of each tine.



WARNING: Exceeding the rated operating load information provided in this document could result in damage to the machine or fork, personal injury, or death.

Pallet and Construction Forks Technical Specifications

950 GC Operating Specifications

ITA Pallet Fork Operating Specifications

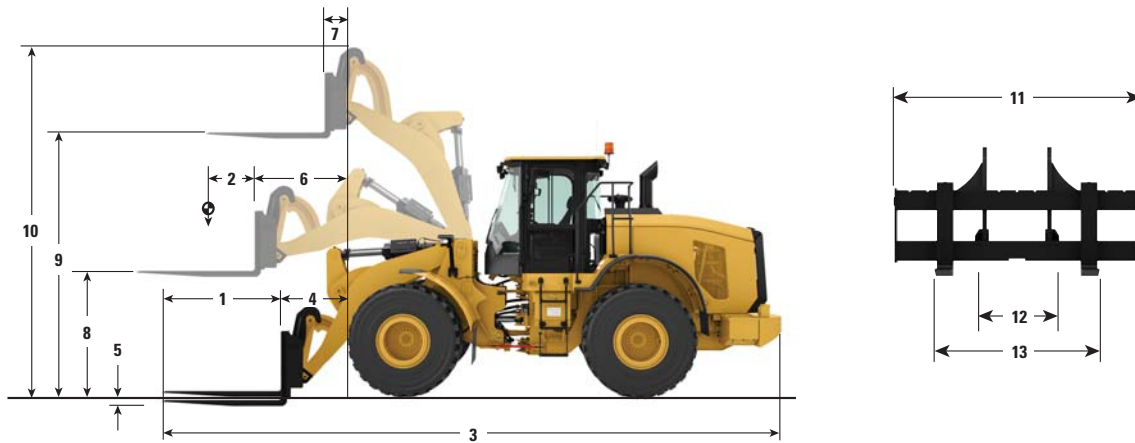

Pallet Fork – Fusion

		60" Tines		72" Tines	
		mm	ft/in	mm	ft/in
1	Fork Tine Length	1524	5'0"	1830	6'0"
2	Load Center	762	2'6"	915	3'0"
3	Length: Overall	8960	29'4"	9266	30'4"
4	Reach: Ground	1266	4'1"	1266	4'1"
5	Dig Depth	-86	-3.40	-86	-3.40
6	Reach: Level Arm	1768	5'9"	1768	5'9"
7	Reach: Full Lift	846	2'9"	846	2'9"
8	Clearance: Level Arm	1759	5'9"	1759	5'9"
9	Clearance: Full Lift	3877	12'8"	3877	12'8"
10	Height: Overall	4100	13'5"	4100	13'5"
11	Carriage Width: Overall	2217	7'3"	2217	7'3"
12	Minimum Fork Spacing	470	1'6"	470	1'6"
13	Maximum Fork Spacing	2070	6'9"	2070	6'9"
	Tine Width	150	6"	150	6"
	Tine Thickness	65	3"	65	3"
		kg	lb	kg	lb
	Load Capacity (per pair)	6300	13,885	5246	11,562
	Tipping Load – Straight*	9106	20,069	8665	19,097
	Tipping Load – Full Turn*	7991	17,612	7597	16,743
	Operating Weight	18 663	41,133	18 710	41,236
	Rated Load % of Full Turn Tip:				
	50% of Tip**	3995	8,804	3799	8,372
	60% of Tip: Rough Terrain***	4794	10,565	4558	10,045
	80% of Tip: Firm and Level***	6182	13,625	5428	11,963

*ISO 14397-1

**SAE J1197 – 50% of full turn static tipping load or hydraulic limit.

***EN474-3 – 80% of full turn static tipping load on firm and level ground or hydraulic limit.



WARNING: Do not exceed tine load capacity. Individual tine capacity is stamped on the side of each tine.



WARNING: Exceeding the rated operating load information provided in this document could result in damage to the machine or fork, personal injury, or death.

Pallet and Construction Forks Technical Specifications

950M Operating Specifications

ITA Pallet Fork Operating Specifications

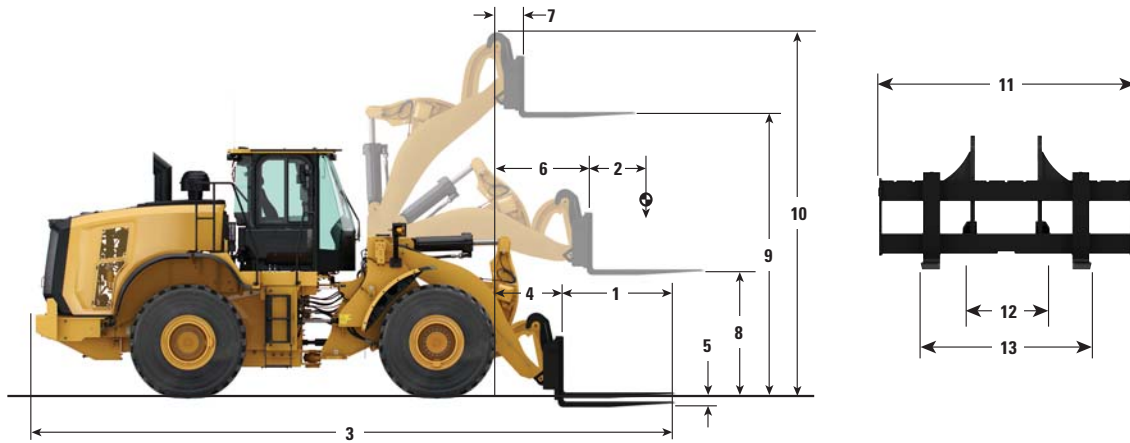

Pallet Fork – Fusion

	60" Tines		72" Tines	
	mm	ft/in	mm	ft/in
1 Fork Tine Length	1524	5'0"	1830	6'0"
2 Load Center	762	2'6"	915	3'0"
3 Length: Overall	8865	29'1"	9171	30'1"
4 Reach: Ground	1243	4'0"	1243	4'0"
5 Dig Depth	-82	-3.2	-82	-3.2
6 Reach: Level Arm	1746	5'8"	1746	5'8"
7 Reach: Full Lift	1031	3'4"	1031	3'4"
8 Clearance: Level Arm	1785	5'10"	1785	5'10"
9 Clearance: Full Lift	3720	12'2"	3720	12'2"
10 Height: Overall	3842	12'7"	3942	12'11"
11 Carriage Width: Overall	2217	7'3"	2217	7'3"
12 Minimum Fork Spacing	470	1'6"	470	1'6"
13 Maximum Fork Spacing	2070	6'9"	2070	6'9"
Tine Width	150	6"	150	6"
Tine Thickness	65	3"	65	3"
	kg	lb	kg	lb
Load Capacity (per pair)	6300	13,885	5246	11,562
Tipping Load – Straight*	9461	20,852	9002	19,840
Tipping Load – Full Turn*	8201	18,075	7796	17,182
Operating Weight	18 903	41,662	18 950	41,766
Rated Load % of Full Turn Tip:				
50% of Tip**	4100	9,036	3898	8,591
60% of Tip: Rough Terrain***	4920	10,844	4677	10,308
80% of Tip: Firm and Level***	6560	14,458	6237	13,746

*ISO 14397-1

**SAE J1197 – 50% of full turn static tipping load or hydraulic limit.

***EN474-3 – 80% of full turn static tipping load on firm and level ground or hydraulic limit.



WARNING: Do not exceed tine load capacity. Individual tine capacity is stamped on the side of each tine.



WARNING: Exceeding the rated operating load information provided in this document could result in damage to the machine or fork, personal injury, or death.

Pallet and Construction Forks Technical Specifications

962M Operating Specifications

ITA Pallet Fork Operating Specifications

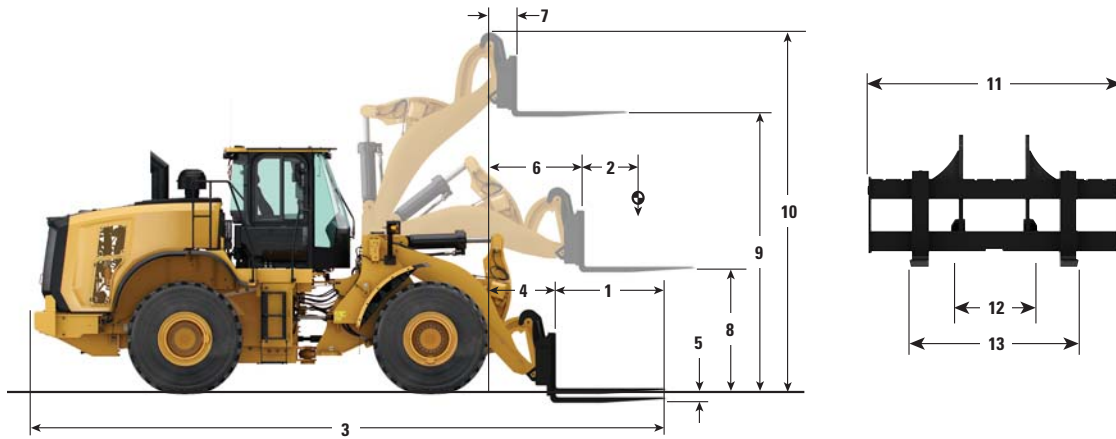

Pallet Fork – Fusion

		60" Tines		72" Tines	
		mm	ft/in	mm	ft/in
1	Fork Tine Length	1524	5'0"	1830	6'0"
2	Load Center	762	2'6"	915	3'0"
3	Length: Overall	9187	29'1"	9493	30'1"
4	Reach: Ground	1360	4'0"	1360	4'0"
5	Dig Depth	-80	-3.2	-80	-3.2
6	Reach: Level Arm	1843	5'8"	1843	5'8"
7	Reach: Full Lift	965	3'4"	965	3'4"
8	Clearance: Level Arm	1785	5'10"	1785	5'10"
9	Clearance: Full Lift	3936	12'2"	3936	12'2"
10	Height: Overall	4159	12'7"	4159	12'11"
11	Carriage Width: Overall	2217	7'3"	2217	7'3"
12	Minimum Fork Spacing	470	1'6"	470	1'6"
13	Maximum Fork Spacing	2070	6'9"	2070	6'9"
	Tine Width	150	6"	150	6"
	Tine Thickness	65	3"	65	3"
		kg	lb	kg	lb
	Load Capacity (per pair)	6300	13,885	5246	11,562
	Tipping Load – Straight*	10 437	20,852	9948	19,840
	Tipping Load – Full Turn*	8995	18,075	8566	17,182
	Operating Weight	19 847	41,662	19 894	41,766
	Rated Load % of Full Turn Tip:				
	50% of Tip**	4497	9,036	4283	8,591
	60% of Tip: Rough Terrain***	5397	10,844	5140	10,308
	80% of Tip: Firm and Level***	7196	14,458	6853	13,746

*ISO 14397-1

**SAE J1197 – 50% of full turn static tipping load or hydraulic limit.

***EN474-3 – 80% of full turn static tipping load on firm and level ground or hydraulic limit.



WARNING: Do not exceed tine load capacity. Individual tine capacity is stamped on the side of each tine.



WARNING: Exceeding the rated operating load information provided in this document could result in damage to the machine or fork, personal injury, or death.

Pallet and Construction Forks Technical Specifications

966M Operating Specifications

ITA Pallet Fork Operating Specifications

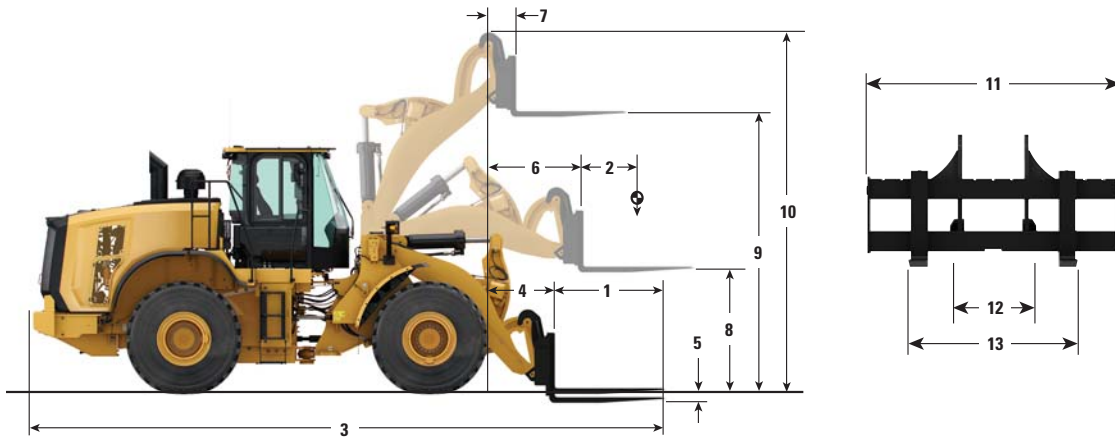

Pallet Fork – Fusion

		60" Tines		72" Tines	
		mm	ft/in	mm	ft/in
1	Fork Tine Length	1524	5'0"	1830	6'0"
2	Load Center	762	2'6"	915	3'0"
3	Length: Overall	9256	29'1"	9562	30'1"
4	Reach: Ground	1136	4'0"	1136	4'0"
5	Dig Depth	-111	-3.2	-111	-3.2
6	Reach: Level Arm	1697	5'8"	1697	5'8"
7	Reach: Full Lift	829	3'4"	829	3'4"
8	Clearance: Level Arm	1856	5'10"	1856	5'10"
9	Clearance: Full Lift	3939	12'2"	3939	12'2"
10	Height: Overall	4161	12'7"	4161	12'11"
11	Carriage Width: Overall	2217	7'3"	2217	7'3"
12	Minimum Fork Spacing	470	1'6"	470	1'6"
13	Maximum Fork Spacing	2070	6'9"	2070	6'9"
	Tine Width	150	6"	150	6"
	Tine Thickness	65	3"	65	3"
		kg	lb	kg	lb
	Load Capacity (per pair)	6300	13,885	5246	11,562
	Tipping Load – Straight*	12 245	20,852	11 668	19,840
	Tipping Load – Full Turn*	10 863	18,075	10 346	17,182
	Operating Weight	22 248	41,662	22 295	41,766
	Rated Load % of Full Turn Tip:				
	50% of Tip**	5431	9,036	5173	8,591
	60% of Tip: Rough Terrain***	6518	10,844	6207	10,308
	80% of Tip: Firm and Level***	8656	14,458	7618	13,746

*ISO 14397-1

**SAE J1197 – 50% of full turn static tipping load or hydraulic limit.

***EN474-3 – 80% of full turn static tipping load on firm and level ground or hydraulic limit.



WARNING: Do not exceed tine load capacity. Individual tine capacity is stamped on the side of each tine.



WARNING: Exceeding the rated operating load information provided in this document could result in damage to the machine or fork, personal injury, or death.

Pallet and Construction Forks Technical Specifications

972M Operating Specifications

ITA Pallet Fork Operating Specifications

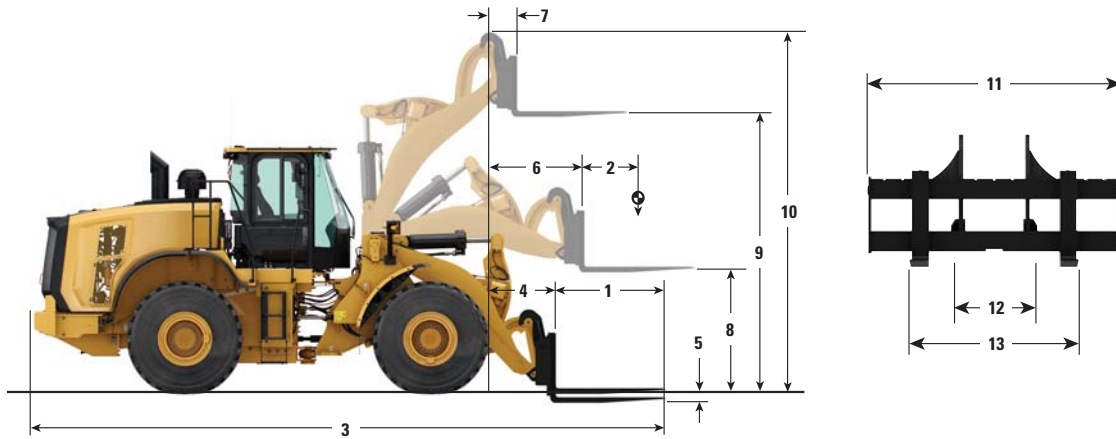

Pallet Fork – Fusion

		60" Tines		72" Tines	
		mm	ft/in	mm	ft/in
1	Fork Tine Length	1524	5'0"	1830	6'0"
2	Load Center	762	2'6"	915	3'0"
3	Length: Overall	9735	29'1"	10 041	30'1"
4	Reach: Ground	1295	4'0"	1295	4'0"
5	Dig Depth	-90	-3.2	-90	-3.2
6	Reach: Level Arm	1827	5'8"	1827	5'8"
7	Reach: Full Lift	782	3'4"	782	3'4"
8	Clearance: Level Arm	1857	5'10"	1857	5'10"
9	Clearance: Full Lift	4162	12'2"	4162	12'2"
10	Height: Overall	4385	12'7"	4385	12'11"
11	Carriage Width: Overall	2217	7'3"	2217	7'3"
12	Minimum Fork Spacing	470	1'6"	470	1'6"
13	Maximum Fork Spacing	2070	6'9"	2070	6'9"
	Tine Width	150	6"	150	6"
	Tine Thickness	65	3"	65	3"
		kg	lb	kg	lb
	Load Capacity (per pair)	6300	13,885	5246	11,562
	Tipping Load – Straight*	13 970	20,852	13 340	19,840
	Tipping Load – Full Turn*	12 288	18,075	11 729	17,182
	Operating Weight	23 943	41,662	23 990	41,766
	Rated Load % of Full Turn Tip:				
	50% of Tip**	6144	9,036	5865	8,591
	60% of Tip: Rough Terrain***	7373	10,844	7038	10,308
	80% of Tip: Firm and Level***	9830	14,458	9383	13,746

*ISO 14397-1

**SAE J1197 – 50% of full turn static tipping load or hydraulic limit.

***EN474-3 – 80% of full turn static tipping load on firm and level ground or hydraulic limit.



WARNING: Do not exceed tine load capacity. Individual tine capacity is stamped on the side of each tine.



WARNING: Exceeding the rated operating load information provided in this document could result in damage to the machine or fork, personal injury, or death.

Pallet and Construction Forks Technical Specifications

980M Operating Specifications

ITA Pallet Fork Operating Specifications

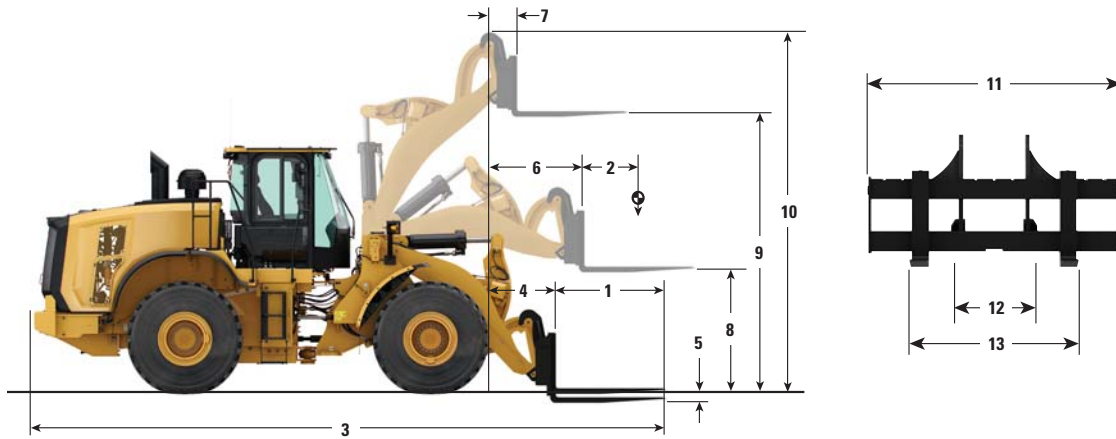

Pallet Fork – Fusion

	60" Tines		72" Tines	
	mm	ft/in	mm	ft/in
1 Fork Tine Length	1524	5'0"	1830	6'0"
2 Load Center	762	2'6"	915	3'0"
3 Length: Overall	9976	29'1"	10 282	30'1"
4 Reach: Ground	1254	4'0"	1254	4'0"
5 Dig Depth	-130	-3.2	-130	-3.2
6 Reach: Level Arm	1833	5'8"	1833	5'8"
7 Reach: Full Lift	906	3'4"	906	3'4"
8 Clearance: Level Arm	1979	5'10"	1979	5'10"
9 Clearance: Full Lift	4247	12'2"	4247	12'2"
10 Height: Overall	4470	12'7"	4470	12'11"
11 Carriage Width: Overall	2217	7'3"	2217	7'3"
12 Minimum Fork Spacing	470	1'6"	470	1'6"
13 Maximum Fork Spacing	2070	6'9"	2070	6'9"
Tine Width	150	6"	150	6"
Tine Thickness	65	3"	65	3"
	kg	lb	kg	lb
Load Capacity (per pair)	6300	13,885	5246	11,562
Tipping Load – Straight*	15 933	20,852	15 233	19,840
Tipping Load – Full Turn*	13 911	18,075	13 294	17,182
Operating Weight	28 152	41,662	28 199	41,766
Rated Load % of Full Turn Tip:				
50% of Tip**	6955	9,036	6647	8,591
60% of Tip: Rough Terrain***	8347	10,844	7976	10,308
80% of Tip: Firm and Level***	9384	14,458	8314	13,746

*ISO 14397-1

**SAE J1197 – 50% of full turn static tipping load or hydraulic limit.

***EN474-3 – 80% of full turn static tipping load on firm and level ground or hydraulic limit.



WARNING: Do not exceed tine load capacity. Individual tine capacity is stamped on the side of each tine.



WARNING: Exceeding the rated operating load information provided in this document could result in damage to the machine or fork, personal injury, or death.

Pallet and Construction Forks Technical Specifications

950 GC Operating Specifications

96" Construction Fork Operating Specifications

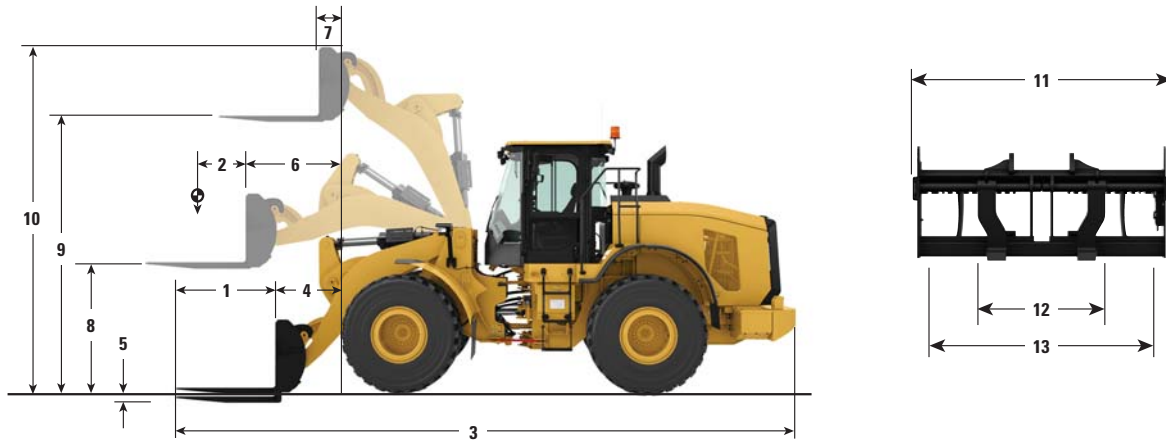

Construction Fork – Fusion

		48" Tines		60" Tines		72" Tines		84" Tines		96" Tines	
		mm	ft/in	mm	ft/in	mm	ft/in	mm	ft/in	mm	ft/in
1	Fork Tine Length	1220	4'0"	1524	5'0"	1830	6'0"	2134	7'0"	2438	7'11"
2	Load Center	610	2'0"	762	2'6"	915	3'0"	1067	3'6"	1220	4'0"
3	Length: Overall	8610	28'2"	8915	29'2"	9220	30'2"	9525	31'2"	9829	32'2"
4	Reach: Ground	1221	4'0"	1221	4'0"	1221	4'0"	1221	4'0"	1221	4'0"
5	Dig Depth	18	0.7"	18	0.7"	18	0.7"	18	0.7"	18	0.7"
6	Reach: Level Arm	1761	5'9"	1761	5'9"	1761	5'9"	1761	5'9"	1761	5'9"
7	Reach: Full Lift	838	2'8"	839	2'9"	839	2'9"	839	2'9"	839	2'9"
8	Clearance: Level Arm	1863	6'1"	1863	6'1"	1863	6'1"	1863	6'1"	1863	6'1"
9	Clearance: Full Lift	3982	13'0"	3982	13'0"	3982	13'0"	3982	13'0"	3982	13'0"
10	Height: Overall	5022	16'5"	5022	16'5"	5022	16'5"	5022	16'5"	5022	16'5"
11	Carriage Width: Overall	2528	8'3"	2528	8'3"	2528	8'3"	2528	8'3"	2528	8'3"
12	Minimum Fork Spacing	576	1'10"	576	1'10"	576	1'10"	576	1'10"	576	1'10"
13	Maximum Fork Spacing	2178	7'1"	2178	7'1"	2178	7'1"	2178	7'1"	2178	7'1"
	Tine Width	180	7"	180	7"	180	7"	180	7"	180	7"
	Tine Thickness	90	4"	90	4"	90	4"	90	4"	90	4"
		kg	lb	kg	lb	kg	lb	kg	lb	kg	lb
	Load Capacity (per pair)	22 200	48,929	17 800	39,231	14 800	32,619	12 700	27,991	11 300	24,905
	Tipping Load – Straight*	9319	20,539	8832	19,466	8386	18,483	7970	17,566	7585	16,717
	Tipping Load – Full Turn*	8149	17,960	7715	17,004	7316	16,124	6944	15,305	6598	14,542
	Operating Weight	18 972	41,814	19 038	41,960	19 099	42,094	19 162	42,233	19 224	42,370
	Rated Load % of Full Turn Tip:										
	50% of Tip**	4075	8,981	3857	8,501	3658	8,062	3472	7,652	3299	7,271
	60% of Tip: Rough Terrain***	4890	10,778	4629	10,202	4390	9,676	4166	9,182	3959	8,726
	80% of Tip: Firm and Level***	6519	14,368	6172	13,603	5658	12,470	5002	11,024	4461	9,832

*ISO 14397-1

**SAE J1197 – 50% of full turn static tipping load or hydraulic limit.

***EN474-3 – 80% of full turn static tipping load on firm and level ground or hydraulic limit.



WARNING: Do not exceed tine load capacity. Individual tine capacity is stamped on the side of each tine.



WARNING: Exceeding the rated operating load information provided in this document could result in damage to the machine or fork, personal injury, or death.

Pallet and Construction Forks Technical Specifications

950 GC Operating Specifications

108" Construction Fork Operating Specifications

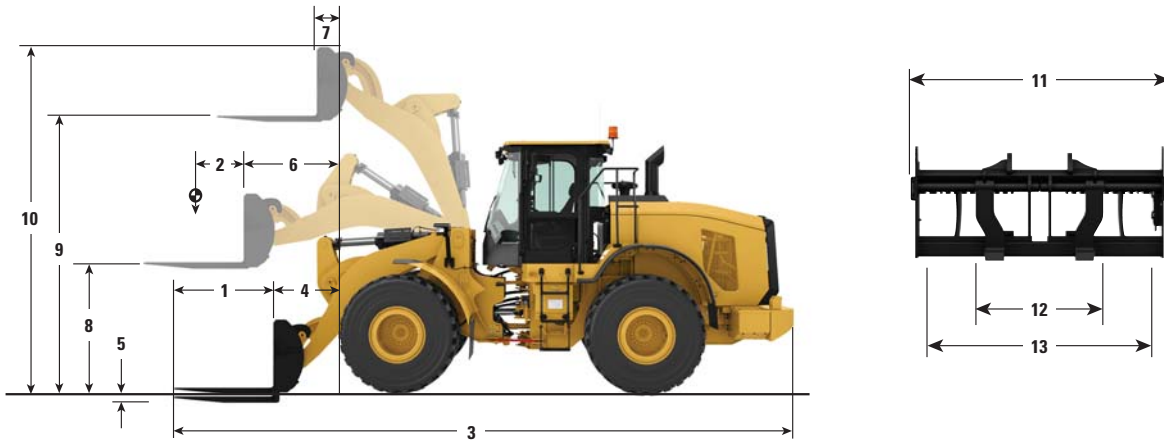

Construction Fork – Fusion

		48" Tines		60" Tines		72" Tines		84" Tines		96" Tines	
		mm	ft/in	mm	ft/in	mm	ft/in	mm	ft/in	mm	ft/in
1	Fork Tine Length	1220	4'0"	1524	5'0"	1830	6'0"	2134	7'0"	2438	7'11"
2	Load Center	610	2'0"	762	2'6"	915	3'0"	1067	3'6"	1219	4'0"
3	Length: Overall	8610	27'11"	8915	28'11"	9220	29'11"	9525	30'11"	9829	31'11"
4	Reach: Ground	1221	3'11"	1221	3'11"	1221	3'11"	1221	3'11"	1221	3'11"
5	Dig Depth	18	0.9"	18	0.9"	18	0.9"	18	0.9"	18	0.9"
6	Reach: Level Arm	1761	5'8"	1656	5'8"	1761	5'8"	1761	5'8"	1761	5'8"
7	Reach: Full Lift	838	3'4"	839	3'4"	839	3'4"	839	3'4"	839	3'4"
8	Clearance: Level Arm	1863	6'2"	1863	6'2"	1863	6'2"	1863	6'2"	1863	6'2"
9	Clearance: Full Lift	3982	12'6"	3982	12'6"	3982	12'6"	3982	12'6"	3982	12'6"
10	Height: Overall	5022	15'11"	5022	15'11"	5022	15'11"	5022	15'11"	5022	15'11"
11	Carriage Width: Overall	2833	8'3"	2833	8'3"	2833	8'3"	2833	8'3"	2833	8'3"
12	Minimum Fork Spacing	590	1'10"	590	1'10"	590	1'10"	590	1'10"	590	1'10"
13	Maximum Fork Spacing	2493	7'1"	2483	7'1"	2483	7'1"	2483	7'1"	2483	7'1"
	Tine Width	180	7"	180	7"	180	7"	180	7"	180	7"
	Tine Thickness	90	4"	90	4"	90	4"	90	4"	90	4"
		kg	lb	kg	lb	kg	lb	kg	lb	kg	lb
	Load Capacity (per pair)	22 200	48,929	17 800	39,231	14 800	32,619	12 700	27,991	14 800	24,905
	Tipping Load – Straight*	9278	21,379	8797	20,259	8351	19,232	7938	18,278	7553	17,394
	Tipping Load – Full Turn*	8109	18,461	7679	17,471	7281	16,567	6911	15,232	6566	14,941
	Operating Weight	19 025	42,343	19 087	42,489	19 149	42,623	19 211	42,762	24 905	42,899
	Rated Load % of Full Turn Tip:										
	50% of Tip**	4054	9,230	3840	8,737	3641	8,283	3456	7,862	3283	7,472
	60% of Tip: Rough Terrain***	4865	11,075	4608	10,482	4369	9,940	4147	9,433	3940	8,964
	80% of Tip: Firm and Level***	6487	14,767	6144	13,978	5649	13,255	4995	12,578	4454	11,952

*ISO 14397-1

**SAE J1197 – 50% of full turn static tipping load or hydraulic limit.

***EN474-3 – 80% of full turn static tipping load on firm and level ground or hydraulic limit.

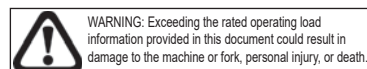
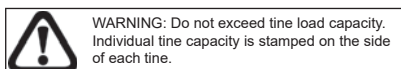

Pallet and Construction Forks Technical Specifications

950M Operating Specifications

96" Construction Fork Operating Specifications

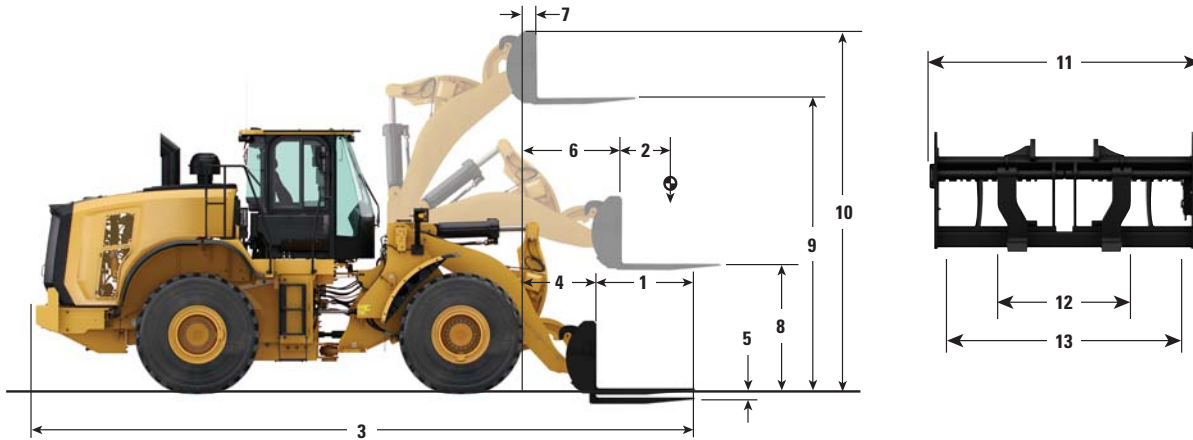

Construction Fork – Fusion

		48" Tines		60" Tines		72" Tines		84" Tines		96" Tines	
		mm	ft/in	mm	ft/in	mm	ft/in	mm	ft/in	mm	ft/in
1	Fork Tine Length	1220	4'0"	1524	5'0"	1830	6'0"	2134	7'0"	2438	7'11"
2	Load Center	610	2'0"	762	2'6"	915	3'0"	1067	3'6"	1220	4'0"
3	Length: Overall	8515	27'11"	8820	28'11"	9125	29'11"	9430	30'11"	9734	31'11"
4	Reach: Ground	1197	3'11"	1198	3'11"	1198	3'11"	1198	3'11"	1198	3'11"
5	Dig Depth	24	0.9"	24	0.9"	24	0.9"	24	0.9"	24	0.9"
6	Reach: Level Arm	1738	5'8"	1738	5'8"	1738	5'8"	1738	5'8"	1738	5'8"
7	Reach: Full Lift	1023	3'4"	1023	3'4"	1023	3'4"	1023	3'4"	1023	3'4"
8	Clearance: Level Arm	1890	6'2"	1890	6'2"	1890	6'2"	1890	6'2"	1890	6'2"
9	Clearance: Full Lift	3825	12'6"	3825	12'6"	3825	12'6"	3825	12'6"	3825	12'6"
10	Height: Overall	4866	15'11"	4866	15'11"	4866	15'11"	4866	15'11"	4866	15'11"
11	Carriage Width: Overall	2528	8'3"	2528	8'3"	2528	8'3"	2528	8'3"	2528	8'3"
12	Minimum Fork Spacing	576	1'10"	576	1'10"	576	1'10"	576	1'10"	576	1'10"
13	Maximum Fork Spacing	2178	7'1"	2178	7'1"	2178	7'1"	2178	7'1"	2178	7'1"
	Tine Width	180	7"	180	7"	180	7"	180	7"	180	7"
	Tine Thickness	90	4"	90	4"	90	4"	90	4"	90	4"
		kg	lb	kg	lb	kg	lb	kg	lb	kg	lb
	Load Capacity (per pair)	22 200	48,929	17 800	39,231	14 800	32,619	12 700	27,991	11 300	24,905
	Tipping Load – Straight*	9700	21,379	9192	20,259	8726	19,232	8293	18,278	7892	17,394
	Tipping Load – Full Turn*	8376	18,461	7927	17,471	7517	16,567	7134	15,723	6779	14,941
	Operating Weight	19 212	42,343	19 278	42,489	19 339	42,623	19 402	42,762	19 464	42,899
	Rated Load % of Full Turn Tip:										
	50% of Tip**	4188	9,230	3964	8,737	3758	8,283	3567	7,862	3390	7,472
	60% of Tip: Rough Terrain***	5025	11,075	4756	10,482	4510	9,940	4280	9,433	4067	8,964
	80% of Tip: Firm and Level***	6700	14,767	6342	13,978	6014	13,255	5707	12,578	5423	11,952

*ISO 14397-1

**SAE J1197 – 50% of full turn static tipping load or hydraulic limit.

***EN474-3 – 80% of full turn static tipping load on firm and level ground or hydraulic limit.



WARNING: Do not exceed tine load capacity. Individual tine capacity is stamped on the side of each tine.



WARNING: Exceeding the rated operating load information provided in this document could result in damage to the machine or fork, personal injury, or death.

Pallet and Construction Forks Technical Specifications

950M Operating Specifications

108" Construction Fork Operating Specifications

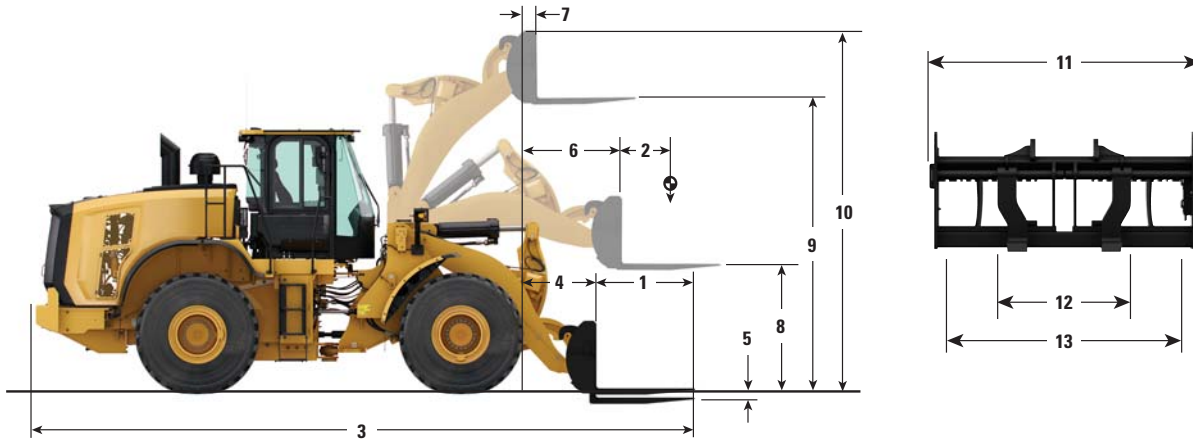

Construction Fork – Fusion

		48" Tines		60" Tines		72" Tines		84" Tines		96" Tines	
		mm	ft/in	mm	ft/in	mm	ft/in	mm	ft/in	mm	ft/in
1	Fork Tine Length	1220	4'0"	1524	5'0"	1830	6'0"	2134	7'0"	2438	7'11"
2	Load Center	610	2'0"	762	2'6"	915	3'0"	1067	3'6"	1220	4'0"
3	Length: Overall	8515	27'11"	8820	28'11"	9125	29'11"	9430	30'11"	9734	31'11"
4	Reach: Ground	1197	3'11"	1197	3'11"	1197	3'11"	1197	3'11"	1197	3'11"
5	Dig Depth	24	0.9"	24	0.9"	24	0.9"	24	0.9"	24	0.9"
6	Reach: Level Arm	1738	5'8"	1738	5'8"	1738	5'8"	1738	5'8"	1738	5'8"
7	Reach: Full Lift	1023	3'4"	1023	3'4"	1023	3'4"	1023	3'4"	1023	3'4"
8	Clearance: Level Arm	1890	6'2"	1890	6'2"	1890	6'2"	1890	6'2"	1890	6'2"
9	Clearance: Full Lift	3825	12'6"	3825	12'6"	3825	12'6"	3825	12'6"	3825	12'6"
10	Height: Overall	4866	15'11"	4866	15'11"	4866	15'11"	4866	15'11"	4866	15'11"
11	Carriage Width: Overall	2833	8'3"	2833	8'3"	2833	8'3"	2833	8'3"	2833	8'3"
12	Minimum Fork Spacing	590	1'10"	590	1'10"	590	1'10"	590	1'10"	590	1'10"
13	Maximum Fork Spacing	2493	7'1"	2493	7'1"	2493	7'1"	2493	7'1"	2493	7'1"
	Tine Width	180	7"	180	7"	180	7"	180	7"	180	7"
	Tine Thickness	90	4"	90	4"	90	4"	90	4"	90	4"
		kg	lb	kg	lb	kg	lb	kg	lb	kg	lb
	Load Capacity (per pair)	22 200	48,929	17 800	39,231	14 800	32,619	12 700	27,991	11 300	24,905
	Tipping Load – Straight*	9659	21,379	9154	20,259	8689	19,232	8259	18,278	7858	17,394
	Tipping Load – Full Turn*	8335	18,461	7889	17,471	7479	16,567	7098	15,644	6744	14,941
	Operating Weight	19 265	42,343	19 327	42,489	19 389	42,623	19 451	42,762	19 514	42,899
	Rated Load % of Full Turn Tip:										
	50% of Tip**	4168	9,230	3944	8,737	3739	8,283	3549	7,862	3372	7,472
	60% of Tip: Rough Terrain***	5001	11,075	4733	10,482	4487	9,940	4259	9,433	4047	8,964
	80% of Tip: Firm and Level***	6668	14,767	6311	13,978	5983	13,255	5679	12,578	5371	11,952

*ISO 14397-1

**SAE J1197 – 50% of full turn static tipping load or hydraulic limit.

***EN474-3 – 80% of full turn static tipping load on firm and level ground or hydraulic limit.



WARNING: Do not exceed tine load capacity. Individual tine capacity is stamped on the side of each tine.



WARNING: Exceeding the rated operating load information provided in this document could result in damage to the machine or fork, personal injury, or death.

Pallet and Construction Forks Technical Specifications

962M Operating Specifications

96" Construction Fork Operating Specifications

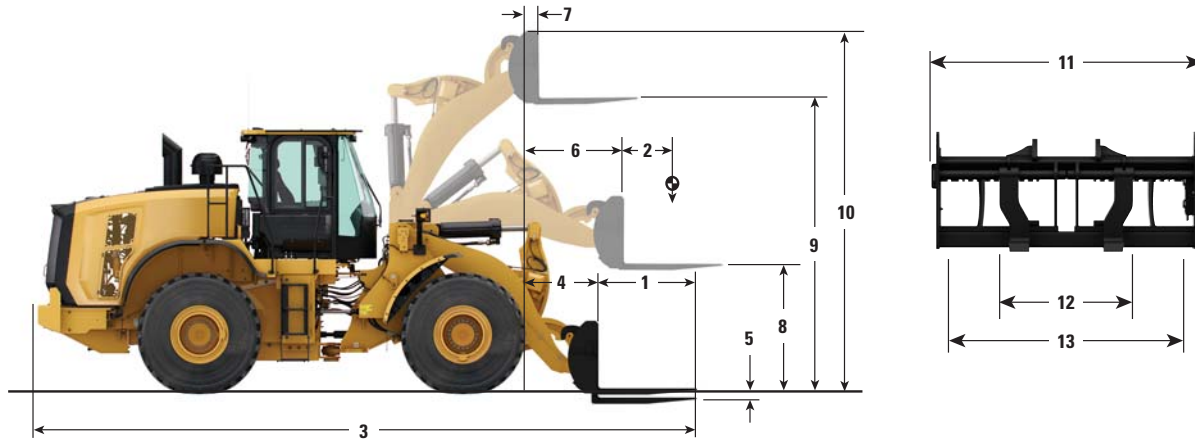

Construction Fork – Fusion

		48" Tines		60" Tines		72" Tines		84" Tines		96" Tines	
		mm	ft/in	mm	ft/in	mm	ft/in	mm	ft/in	mm	ft/in
1	Fork Tine Length	1220	4'0"	1524	5'0"	1830	6'0"	2134	7'0"	2438	7'11"
2	Load Center	610	2'0"	762	2'6"	915	3'0"	1067	3'6"	1220	4'0"
3	Length: Overall	8840	27'11"	9144	28'11"	9449	29'11"	9754	30'11"	10 059	31'11"
4	Reach: Ground	1316	3'11"	1317	3'11"	1317	3'11"	1317	3'11"	1317	3'11"
5	Dig Depth	24	0.9"	24	0.9"	24	0.9"	24	0.9"	24	0.9"
6	Reach: Level Arm	1836	5'8"	1836	5'8"	1836	5'8"	1836	5'8"	1836	5'8"
7	Reach: Full Lift	957	3'4"	957	3'4"	957	3'4"	957	3'4"	957	3'4"
8	Clearance: Level Arm	1890	6'2"	1889	6'2"	1889	6'2"	1889	6'2"	1889	6'2"
9	Clearance: Full Lift	4042	12'6"	4041	12'6"	4041	12'6"	4041	12'6"	4041	12'6"
10	Height: Overall	5082	15'11"	5081	15'11"	5081	15'11"	5081	15'11"	5081	15'11"
11	Carriage Width: Overall	2825	8'3"	2528	8'3"	2528	8'3"	2528	8'3"	2528	8'3"
12	Minimum Fork Spacing	590	1'10"	576	1'10"	576	1'10"	576	1'10"	576	1'10"
13	Maximum Fork Spacing	2493	7'1"	2178	7'1"	2178	7'1"	2178	7'1"	2178	7'1"
	Tine Width	180	7"	180	7"	180	7"	180	7"	180	7"
	Tine Thickness	90	4"	90	4"	90	4"	90	4"	90	4"
		kg	lb	kg	lb	kg	lb	kg	lb	kg	lb
	Load Capacity (per pair)	22 200	48,929	17 800	39,231	14 800	32,619	12 700	27,991	11 300	24,905
	Tipping Load – Straight*	10 665	21,379	10 165	20,259	9669	19,232	9207	18,278	8780	17,394
	Tipping Load – Full Turn*	9152	18,461	8716	17,471	8282	16,567	7877	17,361	7501	14,941
	Operating Weight	20 209	42,343	20 221	42,489	20 283	42,623	20 346	42,762	20 408	42,899
	Rated Load % of Full Turn Tip:										
	50% of Tip**	4576	9,230	4358	8,737	4141	8,283	3938	7,862	3751	7,472
	60% of Tip: Rough Terrain***	5491	11,075	5230	10,482	4969	9,940	4726	9,433	4501	8,964
	80% of Tip: Firm and Level***	7321	14,767	6973	13,978	6626	13,255	6302	12,578	6001	11,952

*ISO 14397-1

**SAE J1197 – 50% of full turn static tipping load or hydraulic limit.

***EN474-3 – 80% of full turn static tipping load on firm and level ground or hydraulic limit.



WARNING: Do not exceed tine load capacity. Individual tine capacity is stamped on the side of each tine.



WARNING: Exceeding the rated operating load information provided in this document could result in damage to the machine or fork, personal injury, or death.

Pallet and Construction Forks Technical Specifications

962M Operating Specifications

108" Construction Fork Operating Specifications

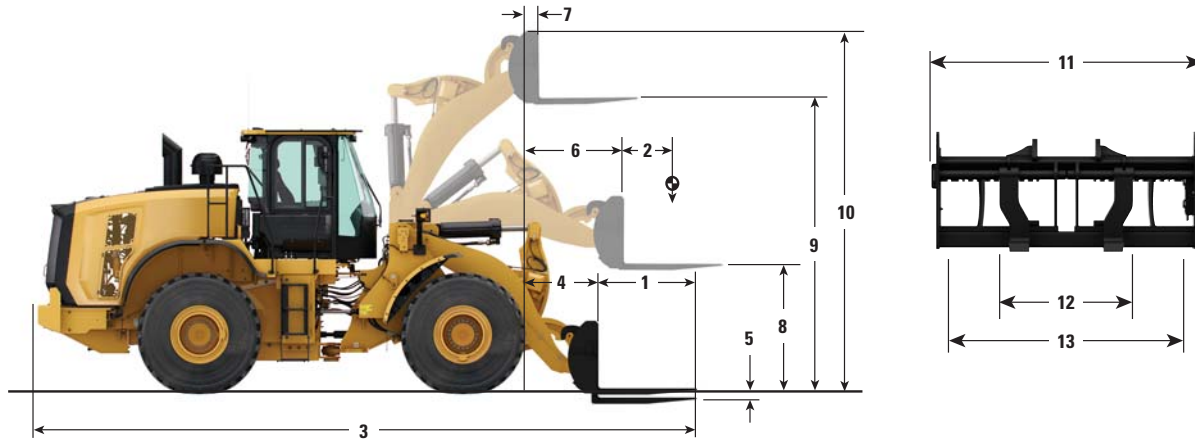

Construction Fork – Fusion

		48" Tines		60" Tines		72" Tines		84" Tines		96" Tines	
		mm	ft/in	mm	ft/in	mm	ft/in	mm	ft/in	mm	ft/in
1	Fork Tine Length	1220	4'0"	1524	5'0"	1830	6'0"	2134	7'0"	2438	7'11"
2	Load Center	610	2'0"	762	2'6"	915	3'0"	1067	3'6"	1220	4'0"
3	Length: Overall	8838	27'11"	9144	28'11"	9449	29'11"	9754	30'11"	10 058	31'11"
4	Reach: Ground	1316	3'11"	1316	3'11"	1316	3'11"	1316	3'11"	1316	3'11"
5	Dig Depth	25	0.9"	25	0.9"	25	0.9"	25	0.9"	25	0.9"
6	Reach: Level Arm	1835	5'8"	1835	5'8"	1835	5'8"	1835	5'8"	1835	5'8"
7	Reach: Full Lift	957	3'4"	957	3'4"	957	3'4"	957	3'4"	957	3'4"
8	Clearance: Level Arm	1890	6'2"	1890	6'2"	1890	6'2"	1890	6'2"	1890	6'2"
9	Clearance: Full Lift	4042	12'6"	4042	12'6"	4042	12'6"	4042	12'6"	4042	12'6"
10	Height: Overall	5082	15'11"	5082	15'11"	5082	15'11"	5082	15'11"	5082	15'11"
11	Carriage Width: Overall	2833	8'3"	2833	8'3"	2833	8'3"	2833	8'3"	2833	8'3"
12	Minimum Fork Spacing	590	1'10"	590	1'10"	590	1'10"	590	1'10"	590	1'10"
13	Maximum Fork Spacing	2493	7'1"	2493	7'1"	2493	7'1"	2493	7'1"	2493	7'1"
	Tine Width	180	7"	180	7"	180	7"	180	7"	180	7"
	Tine Thickness	90	4"	90	4"	90	4"	90	4"	90	4"
		kg	lb	kg	lb	kg	lb	kg	lb	kg	lb
	Load Capacity (per pair)	22 200	48,929	17 800	39,231	14 800	32,619	12 700	27,991	11 300	24,905
	Tipping Load – Straight*	10 665	21,379	10 165	20,259	9669	19,232	9207	18,278	8780	17,394
	Tipping Load – Full Turn*	9152	18,461	8716	17,471	8282	16,567	7877	17,361	7501	14,941
	Operating Weight	20 209	42,343	20 221	42,489	20 283	42,623	20 346	42,762	20 408	42,899
	Rated Load % of Full Turn Tip:										
	50% of Tip**	4576	9,230	4358	8,737	4141	8,283	3938	7,862	3751	7,472
	60% of Tip: Rough Terrain***	5491	11,075	5230	10,482	4969	9,940	4726	9,433	4501	8,964
	80% of Tip: Firm and Level***	7321	14,767	6973	13,978	6626	13,255	6302	12,578	6001	11,952

*ISO 14397-1

**SAE J1197 – 50% of full turn static tipping load or hydraulic limit.

***EN474-3 – 80% of full turn static tipping load on firm and level ground or hydraulic limit.



WARNING: Do not exceed tine load capacity. Individual tine capacity is stamped on the side of each tine.



WARNING: Exceeding the rated operating load information provided in this document could result in damage to the machine or fork, personal injury, or death.

Pallet and Construction Forks Technical Specifications

966M Operating Specifications

96" Construction Fork Operating Specifications

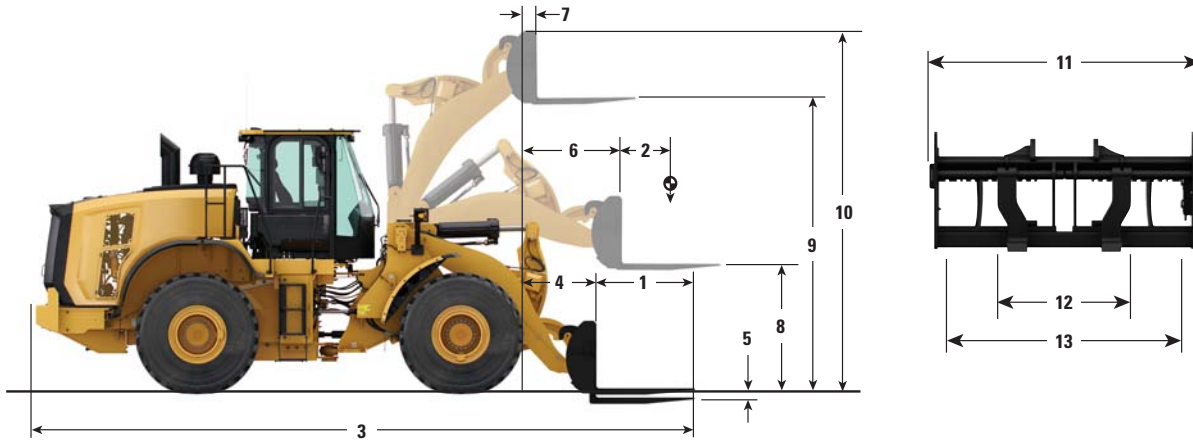

Construction Fork – Fusion

		48" Tines		60" Tines		72" Tines		84" Tines		96" Tines	
		mm	ft/in	mm	ft/in	mm	ft/in	mm	ft/in	mm	ft/in
1	Fork Tine Length	1220	4'0"	1524	5'0"	1830	6'0"	2134	7'0"	2438	7'11"
2	Load Center	610	2'0"	762	2'6"	915	3'0"	1067	3'6"	1220	4'0"
3	Length: Overall	8903	27'11"	9226	28'11"	9531	29'11"	9836	30'11"	10 140	31'11"
4	Reach: Ground	1087	3'11"	1106	3'11"	1106	3'11"	1106	3'11"	1106	3'11"
5	Dig Depth	-7	0.9"	-7	0.9"	-7	0.9"	-7	0.9"	-7	0.9"
6	Reach: Level Arm	1688	5'8"	1688	5'8"	1688	5'8"	1688	5'8"	1688	5'8"
7	Reach: Full Lift	821	3'4"	821	3'4"	821	3'4"	821	3'4"	821	3'4"
8	Clearance: Level Arm	1960	6'2"	1960	6'2"	1960	6'2"	1960	6'2"	1960	6'2"
9	Clearance: Full Lift	4043	12'6"	4043	12'6"	4043	12'6"	4043	12'6"	4043	12'6"
10	Height: Overall	5083	15'11"	5083	15'11"	5083	15'11"	5083	15'11"	5083	15'11"
11	Carriage Width: Overall	2528	8'3"	2528	8'3"	2528	8'3"	2528	8'3"	2528	8'3"
12	Minimum Fork Spacing	576	1'10"	576	1'10"	576	1'10"	576	1'10"	576	1'10"
13	Maximum Fork Spacing	2178	7'1"	2178	7'1"	2178	7'1"	2178	7'1"	2178	7'1"
	Tine Width	180	7"	180	7"	180	7"	180	7"	180	7"
	Tine Thickness	90	4"	90	4"	90	4"	90	4"	90	4"
		kg	lb	kg	lb	kg	lb	kg	lb	kg	lb
	Load Capacity (per pair)	22 200	48,929	17 800	39,231	14 800	32,619	12 700	27,991	11 300	24,905
	Tipping Load – Straight*	12 620	21,379	11 924	20,259	11 345	19,232	10 807	18,278	10 310	17,394
	Tipping Load – Full Turn*	11 168	18,461	10 532	17,471	10 013	16,567	9531	21,006	9085	14,941
	Operating Weight	22 557	42,343	22 621	42,489	22 683	42,623	22 746	42,762	22 808	42,899
	Rated Load % of Full Turn Tip:										
	50% of Tip**	5584	9,230	5266	8,737	5007	8,283	4766	7,862	4542	7,472
	60% of Tip: Rough Terrain***	6701	11,075	6319	10,482	6008	9,940	5719	9,433	5451	8,964
	80% of Tip: Firm and Level***	8934	14,767	8426	13,978	7807	13,255	6937	12,578	6222	11,952

*ISO 14397-1

**SAE J1197 – 50% of full turn static tipping load or hydraulic limit.

***EN474-3 – 80% of full turn static tipping load on firm and level ground or hydraulic limit.



WARNING: Do not exceed tine load capacity. Individual tine capacity is stamped on the side of each tine.



WARNING: Exceeding the rated operating load information provided in this document could result in damage to the machine or fork, personal injury, or death.

Pallet and Construction Forks Technical Specifications

966M Operating Specifications

108" Construction Fork Operating Specifications

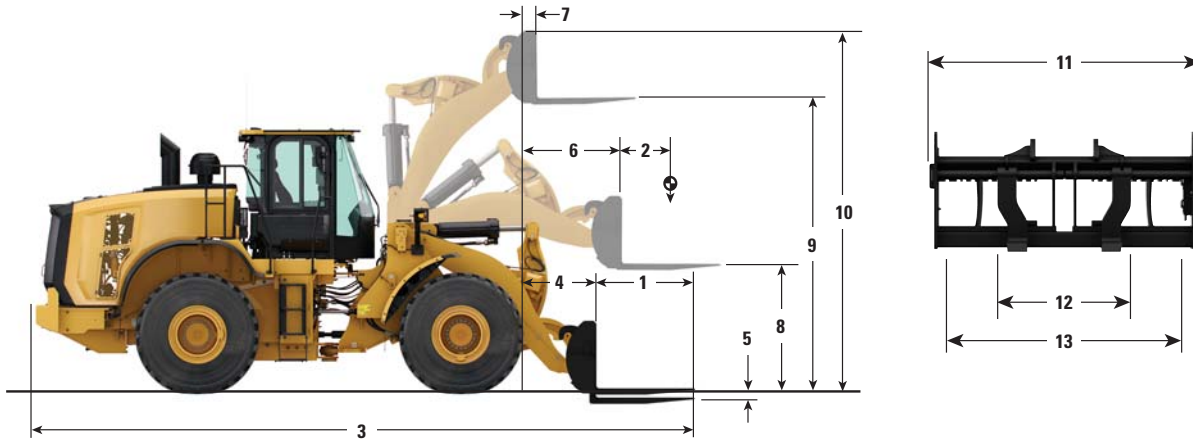

Construction Fork – Fusion

		48" Tines		60" Tines		72" Tines		84" Tines		96" Tines	
		mm	ft/in	mm	ft/in	mm	ft/in	mm	ft/in	mm	ft/in
1	Fork Tine Length	1220	4'0"	1524	5'0"	1830	6'0"	2134	7'0"	2438	7'11"
2	Load Center	610	2'0"	762	2'6"	915	3'0"	1067	3'6"	1220	4'0"
3	Length: Overall	8903	27'11"	9226	28'11"	9531	29'11"	9836	30'11"	10 140	31'11"
4	Reach: Ground	1087	3'11"	1087	3'11"	1087	3'11"	1087	3'11"	1087	3'11"
5	Dig Depth	-7	0.9"	-7	0.9"	-7	0.9"	-7	0.9"	-7	0.9"
6	Reach: Level Arm	1688	5'8"	1688	5'8"	1688	5'8"	1688	5'8"	1688	5'8"
7	Reach: Full Lift	821	3'4"	821	3'4"	821	3'4"	821	3'4"	821	3'4"
8	Clearance: Level Arm	1960	6'2"	1960	6'2"	1960	6'2"	1960	6'2"	1960	6'2"
9	Clearance: Full Lift	4043	12'6"	4043	12'6"	4043	12'6"	4043	12'6"	4043	12'6"
10	Height: Overall	5083	15'11"	5083	15'11"	5083	15'11"	5083	15'11"	5083	15'11"
11	Carriage Width: Overall	2833	8'3"	2833	8'3"	2833	8'3"	2833	8'3"	2833	8'3"
12	Minimum Fork Spacing	590	1'10"	590	1'10"	590	1'10"	590	1'10"	590	1'10"
13	Maximum Fork Spacing	2493	7'1"	2493	7'1"	2493	7'1"	2493	7'1"	2493	7'1"
	Tine Width	180	7"	180	7"	180	7"	180	7"	180	7"
	Tine Thickness	90	4"	90	4"	90	4"	90	4"	90	4"
		kg	lb	kg	lb	kg	lb	kg	lb	kg	lb
	Load Capacity (per pair)	22 200	48,929	17 800	39,231	14 800	32,619	12 700	27,991	11 300	24,905
	Tipping Load – Straight*	12 579	21,379	11 888	20,259	11 310	19,232	10 775	18,278	10 278	17,394
	Tipping Load – Full Turn*	11 128	18,461	10 497	17,471	9979	16,567	9499	20,935	9053	14,941
	Operating Weight	22 610	42,343	22 671	42,489	22 733	42,623	22 795	42,762	22 858	42,899
	Rated Load % of Full Turn Tip:										
	50% of Tip**	5564	9,230	5248	8,737	4989	8,283	4749	7,862	4526	7,472
	60% of Tip: Rough Terrain***	6677	11,075	6298	10,482	5987	9,940	5699	9,433	5432	8,964
	80% of Tip: Firm and Level***	8902	14,767	8397	13,978	7799	13,255	6930	12,578	6215	11,952

*ISO 14397-1

**SAE J1197 – 50% of full turn static tipping load or hydraulic limit.

***EN474-3 – 80% of full turn static tipping load on firm and level ground or hydraulic limit.



WARNING: Do not exceed tine load capacity. Individual tine capacity is stamped on the side of each tine.



WARNING: Exceeding the rated operating load information provided in this document could result in damage to the machine or fork, personal injury, or death.

Pallet and Construction Forks Technical Specifications

972M Operating Specifications

96" Construction Fork Operating Specifications

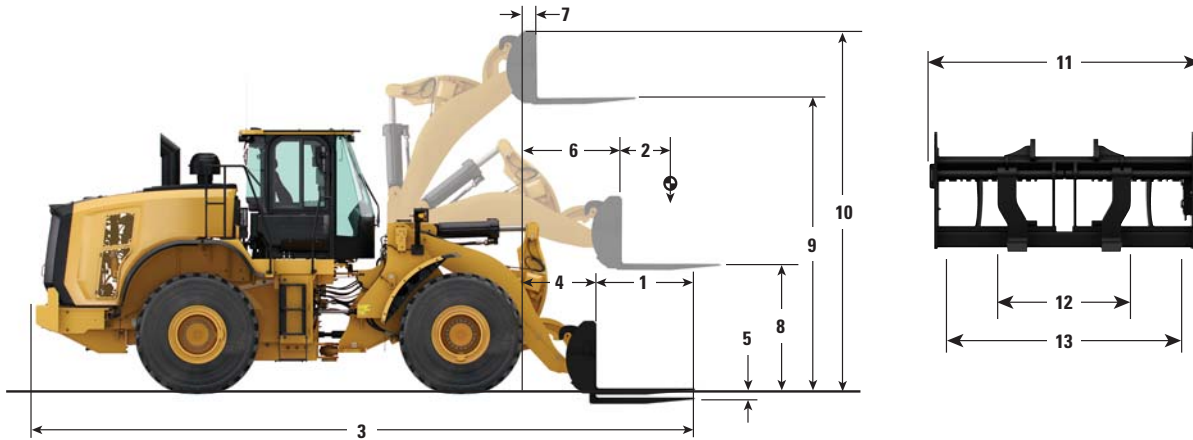

Construction Fork – Fusion

		48" Tines		60" Tines		72" Tines		84" Tines		96" Tines	
		mm	ft/in	mm	ft/in	mm	ft/in	mm	ft/in	mm	ft/in
1	Fork Tine Length	1220	4'0"	1524	5'0"	1830	6'0"	2134	7'0"	2438	7'11"
2	Load Center	610	2'0"	762	2'6"	915	3'0"	1067	3'6"	1220	4'0"
3	Length: Overall	9384	27'11"	9707	28'11"	10 012	29'11"	9430	30'11"	10 621	31'11"
4	Reach: Ground	1248	3'11"	1248	3'11"	1248	3'11"	1248	3'11"	1248	3'11"
5	Dig Depth	14	0.9"	14	0.9"	14	0.9"	14	0.9"	14	0.9"
6	Reach: Level Arm	1818	5'8"	1818	5'8"	1818	5'8"	1818	5'8"	1818	5'8"
7	Reach: Full Lift	773	3'4"	773	3'4"	773	3'4"	773	3'4"	773	3'4"
8	Clearance: Level Arm	1961	6'2"	1961	6'2"	1961	6'2"	1961	6'2"	1961	6'2"
9	Clearance: Full Lift	4266	12'6"	4266	12'6"	4266	12'6"	4266	12'6"	4266	12'6"
10	Height: Overall	5307	15'11"	5307	15'11"	5307	15'11"	5307	15'11"	5307	15'11"
11	Carriage Width: Overall	2528	8'3"	2528	8'3"	2528	8'3"	2528	8'3"	2528	8'3"
12	Minimum Fork Spacing	576	1'10"	576	1'10"	576	1'10"	576	1'10"	576	1'10"
13	Maximum Fork Spacing	2178	7'1"	2178	7'1"	2178	7'1"	2178	7'1"	2178	7'1"
	Tine Width	180	7"	180	7"	180	7"	180	7"	180	7"
	Tine Thickness	90	4"	90	4"	90	4"	90	4"	90	4"
		kg	lb	kg	lb	kg	lb	kg	lb	kg	lb
	Load Capacity (per pair)	22 200	48,929	17 800	39,231	14 800	32,619	12 700	27,991	11 300	24,905
	Tipping Load – Straight*	14 400	21,379	13 644	20,259	13 012	19,232	12 425	18,278	11 881	17,394
	Tipping Load – Full Turn*	12 636	18,461	11 963	17,471	11 401	16,567	10 879	23,977	10 394	14,941
	Operating Weight	22 557	42,343	24 316	42,489	24 378	42,623	24 441	42,762	24 503	42,899
	Rated Load % of Full Turn Tip:										
	50% of Tip**	6318	9,230	5981	8,737	5701	8,283	5439	7,862	5197	7,472
	60% of Tip: Rough Terrain***	7581	11,075	7178	10,482	6841	9,940	6527	9,433	6237	8,964
	80% of Tip: Firm and Level***	10 108	14,767	9570	13,978	9121	13,255	8703	12,578	8315	11,952

*ISO 14397-1

**SAE J1197 – 50% of full turn static tipping load or hydraulic limit.

***EN474-3 – 80% of full turn static tipping load on firm and level ground or hydraulic limit.



WARNING: Do not exceed tine load capacity. Individual tine capacity is stamped on the side of each tine.



WARNING: Exceeding the rated operating load information provided in this document could result in damage to the machine or fork, personal injury, or death.

Pallet and Construction Forks Technical Specifications

972M Operating Specifications

108" Construction Fork Operating Specifications

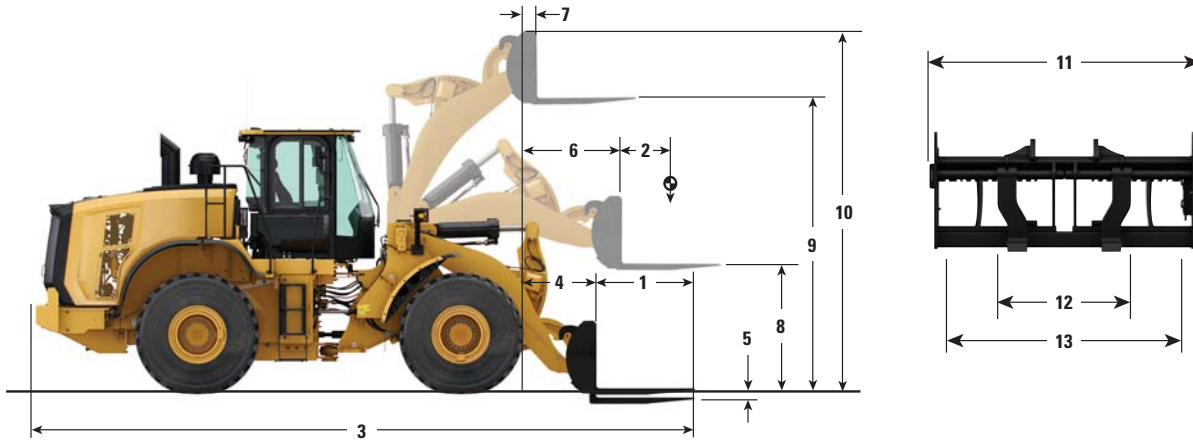

Construction Fork – Fusion

		48" Tines		60" Tines		72" Tines		84" Tines		96" Tines	
		mm	ft/in	mm	ft/in	mm	ft/in	mm	ft/in	mm	ft/in
1	Fork Tine Length	1220	4'0"	1524	5'0"	1830	6'0"	2134	7'0"	2438	7'11"
2	Load Center	610	2'0"	762	2'6"	915	3'0"	1067	3'6"	1220	4'0"
3	Length: Overall	9384	27'11"	9707	28'11"	10 012	29'11"	9430	30'11"	10 621	31'11"
4	Reach: Ground	1248	3'11"	1248	3'11"	1248	3'11"	1248	3'11"	1248	3'11"
5	Dig Depth	14	0.9"	14	0.9"	14	0.9"	14	0.9"	14	0.9"
6	Reach: Level Arm	1818	5'8"	1818	5'8"	1818	5'8"	1818	5'8"	1818	5'8"
7	Reach: Full Lift	773	3'4"	773	3'4"	773	3'4"	773	3'4"	773	3'4"
8	Clearance: Level Arm	1961	6'2"	1961	6'2"	1961	6'2"	1961	6'2"	1961	6'2"
9	Clearance: Full Lift	4266	12'6"	4266	12'6"	4266	12'6"	4266	12'6"	4266	12'6"
10	Height: Overall	5307	15'11"	5307	15'11"	5307	15'11"	5307	15'11"	5307	15'11"
11	Carriage Width: Overall	2833	8'3"	2833	8'3"	2833	8'3"	2833	8'3"	2833	8'3"
12	Minimum Fork Spacing	590	1'10"	590	1'10"	590	1'10"	590	1'10"	590	1'10"
13	Maximum Fork Spacing	2493	7'1"	2493	7'1"	2493	7'1"	2493	7'1"	2493	7'1"
	Tine Width	180	7"	180	7"	180	7"	180	7"	180	7"
	Tine Thickness	90	4"	90	4"	90	4"	90	4"	90	4"
		kg	lb	kg	lb	kg	lb	kg	lb	kg	lb
	Load Capacity (per pair)	22 200	48,929	17 800	39,231	14 800	32,619	12 700	27,991	11 300	24,905
	Tipping Load – Straight*	14 359	21,379	13 607	20,259	12 977	19,232	12 392	18,278	11 848	17,394
	Tipping Load – Full Turn*	12 595	18,461	11 927	17,471	11 366	16,567	10 846	23,905	10 362	14,941
	Operating Weight	24 305	42,343	24 366	42,489	24 428	42,623	24 490	42,762	24 553	42,899
	Rated Load % of Full Turn Tip:										
	50% of Tip**	6297	9,230	5963	8,737	5683	8,283	5423	7,862	5181	7,472
	60% of Tip: Rough Terrain***	7557	11,075	7156	10,482	6820	9,940	6508	9,433	6217	8,964
	80% of Tip: Firm and Level***	10 076	14,767	9541	13,978	9093	13,255	8677	12,578	8289	11,952

*ISO 14397-1

**SAE J1197 – 50% of full turn static tipping load or hydraulic limit.

***EN474-3 – 80% of full turn static tipping load on firm and level ground or hydraulic limit.



WARNING: Do not exceed tine load capacity. Individual tine capacity is stamped on the side of each tine.



WARNING: Exceeding the rated operating load information provided in this document could result in damage to the machine or fork, personal injury, or death.

Pallet and Construction Forks Technical Specifications

980M Operating Specifications

96" Construction Fork Operating Specifications

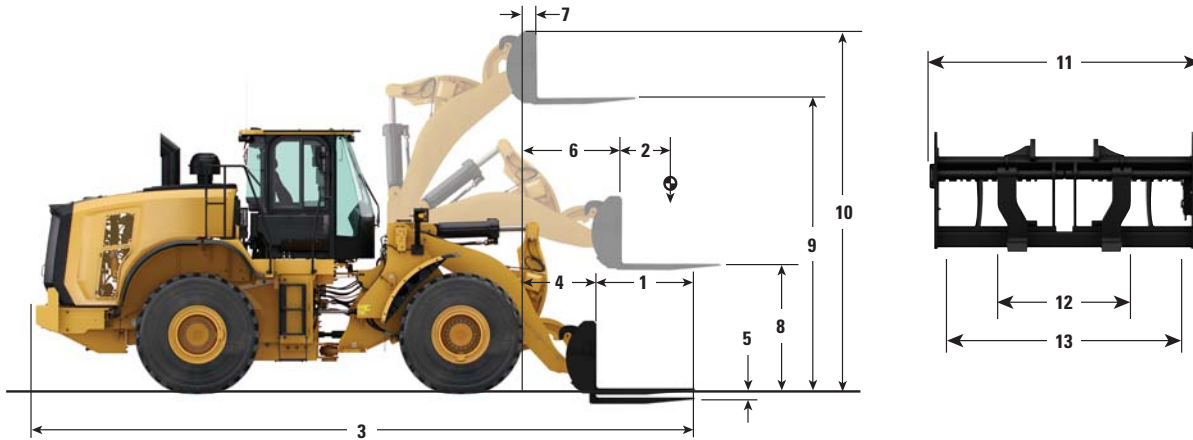

Construction Fork – Fusion

		48" Tines		60" Tines		72" Tines		84" Tines		96" Tines	
		mm	ft/in	mm	ft/in	mm	ft/in	mm	ft/in	mm	ft/in
1	Fork Tine Length	1220	4'0"	1524	(5'0")	1830	6'0"	2134	7'0"	2438	7'11"
2	Load Center	610	2'0"	762	2'6"	915	3'0"	1067	3'6"	1220	4'0"
3	Length: Overall	9615	27'11"	9920	28'11"	10 225	29'11"	9430	30'11"	10 834	31'11"
4	Reach: Ground	1197	3'11"	1197	3'11"	1197	3'11"	1197	3'11"	1197	3'11"
5	Dig Depth	-19	0.9"	-19	0.9"	-19	0.9"	-19	0.9"	-19	0.9"
6	Reach: Level Arm	1820	5'8"	1820	5'8"	1820	5'8"	1820	5'8"	1820	5'8"
7	Reach: Full Lift	893	3'4"	893	3'4"	893	3'4"	893	3'4"	893	3'4"
8	Clearance: Level Arm	2090	6'2"	2090	6'2"	2090	6'2"	2090	6'2"	2090	6'2"
9	Clearance: Full Lift	4358	12'6"	4358	12'6"	4358	12'6"	4358	12'6"	4358	12'6"
10	Height: Overall	5399	15'11"	5399	15'11"	5399	15'11"	5399	15'11"	5399	15'11"
11	Carriage Width: Overall	2528	8'3"	2528	8'3"	2528	8'3"	2528	8'3"	2528	8'3"
12	Minimum Fork Spacing	576	1'10"	576	1'10"	576	1'10"	576	1'10"	576	1'10"
13	Maximum Fork Spacing	2178	7'1"	2178	7'1"	2178	7'1"	2178	7'1"	2178	7'1"
	Tine Width	180	7"	180	7"	180	7"	180	7"	180	7"
	Tine Thickness	90	4"	90	4"	90	4"	90	4"	90	4"
		kg	lb	kg	lb	kg	lb	kg	lb	kg	lb
	Load Capacity (per pair)	22 200	48,929	17 800	39,231	14 800	32,619	12 700	27,991	11 300	24,905
	Tipping Load – Straight*	16 467	21,379	15 698	20,259	14 989	19,232	14 330	18,278	13 719	17,394
	Tipping Load – Full Turn*	14 343	18,461	13 667	17,471	13 043	16,567	12 461	27,464	11 921	14,941
	Operating Weight	28 461	42,343	28 527	42,489	28 588	42,623	28 651	42,762	28 713	42,899
	Rated Load % of Full Turn Tip:										
	50% of Tip**	7173	9,230	6834	8,737	6521	8,283	6230	7,862	5961	7,472
	60% of Tip: Rough Terrain***	8607	11,075	8200	10,482	7826	9,940	7476	9,433	6986	8,964
	80% of Tip: Firm and Level***	11 474	14,767	10 934	13,978	10 434	13,255	9969	12,578	9536	11,952

*ISO 14397-1

**SAE J1197 – 50% of full turn static tipping load or hydraulic limit.

***EN474-3 – 80% of full turn static tipping load on firm and level ground or hydraulic limit.



WARNING: Do not exceed tine load capacity. Individual tine capacity is stamped on the side of each tine.



WARNING: Exceeding the rated operating load information provided in this document could result in damage to the machine or fork, personal injury, or death.

Pallet and Construction Forks Technical Specifications

980M Operating Specifications

108" Construction Fork Operating Specifications

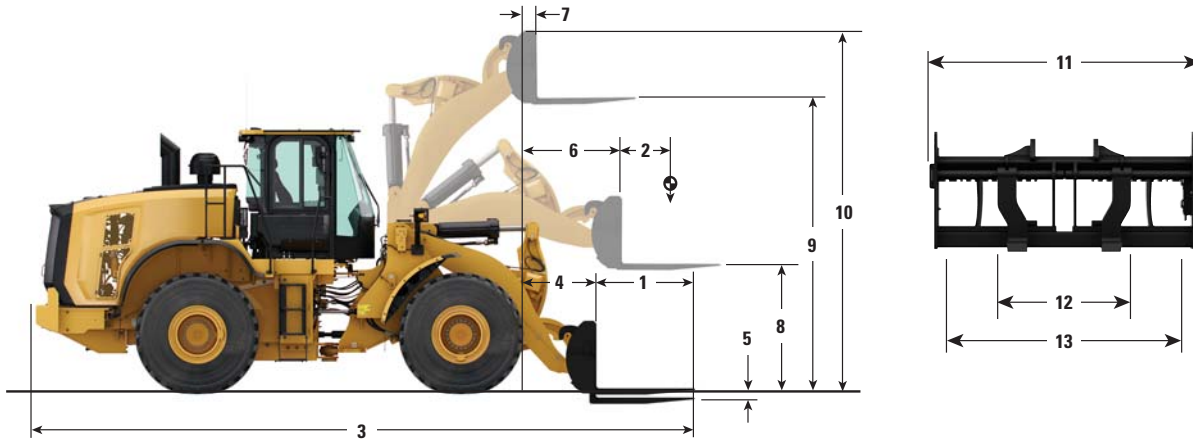

Construction Fork – Fusion

		48" Tines		60" Tines		72" Tines		84" Tines		96" Tines	
		mm	ft/in	mm	ft/in	mm	ft/in	mm	ft/in	mm	ft/in
1	Fork Tine Length	1220	4'0"	1524	5'0"	1830	6'0"	2134	7'0"	2438	7'11"
2	Load Center	610	2'0"	762	2'6"	915	3'0"	1067	3'6"	1220	4'0"
3	Length: Overall	9615	27'11"	9920	28'11"	10 225	29'11"	9430	30'11"	10 834	31'11"
4	Reach: Ground	1197	3'11"	1197	3'11"	1197	3'11"	1197	3'11"	1197	3'11"
5	Dig Depth	-19	0.9"	-19	0.9"	-19	0.9"	-19	0.9"	-19	0.9"
6	Reach: Level Arm	1820	5'8"	1820	5'8"	1820	5'8"	1820	5'8"	1820	5'8"
7	Reach: Full Lift	893	3'4"	893	3'4"	893	3'4"	893	3'4"	893	3'4"
8	Clearance: Level Arm	2090	6'2"	2090	6'2"	2090	6'2"	2090	6'2"	2090	6'2"
9	Clearance: Full Lift	4358	12'6"	4358	12'6"	4358	12'6"	4358	12'6"	4358	12'6"
10	Height: Overall	5399	15'11"	5399	15'11"	5399	15'11"	5399	15'11"	5399	15'11"
11	Carriage Width: Overall	2833	8'3"	2833	8'3"	2833	8'3"	2833	8'3"	2833	8'3"
12	Minimum Fork Spacing	590	1'10"	590	1'10"	590	1'10"	590	1'10"	590	1'10"
13	Maximum Fork Spacing	2493	7'1"	2493	7'1"	2493	7'1"	2493	7'1"	2493	7'1"
	Tine Width	180	7"	180	7"	180	7"	180	7"	180	7"
	Tine Thickness	90	4"	90	4"	90	4"	90	4"	90	4"
		kg	lb	kg	lb	kg	lb	kg	lb	kg	lb
	Load Capacity (per pair)	22 200	48,929	17 800	39,231	14 800	32,619	12 700	27,991	11 300	24,905
	Tipping Load – Straight*	16 426	21,379	15 662	20,259	14 954	19,232	14 297	18,278	13 687	17,394
	Tipping Load – Full Turn*	14 304	18,461	13 632	17,471	13 007	16,567	12 428	27,391	11 888	14,941
	Operating Weight	28 514	42,343	28 576	42,489	28 638	42,623	28 700	42,762	28 763	42,899
	Rated Load % of Full Turn Tip:										
	50% of Tip**	7152	9,230	6816	8,737	6504	8,283	6214	7,862	5944	7,472
	60% of Tip: Rough Terrain***	8583	11,075	8179	10,482	7804	9,940	7457	9,433	6978	8,964
	80% of Tip: Firm and Level***	11 443	14,767	10 906	13,978	10 406	13,255	9 942	12,578	9 510	11,952

*ISO 14397-1

**SAE J1197 – 50% of full turn static tipping load or hydraulic limit.

***EN474-3 – 80% of full turn static tipping load on firm and level ground or hydraulic limit.



WARNING: Do not exceed tine load capacity. Individual tine capacity is stamped on the side of each tine.



WARNING: Exceeding the rated operating load information provided in this document could result in damage to the machine or fork, personal injury, or death.

Pallet and Construction Forks Technical Specifications

950 GC Operating Specifications

87" Carriage Pallet Fork Operating Specifications

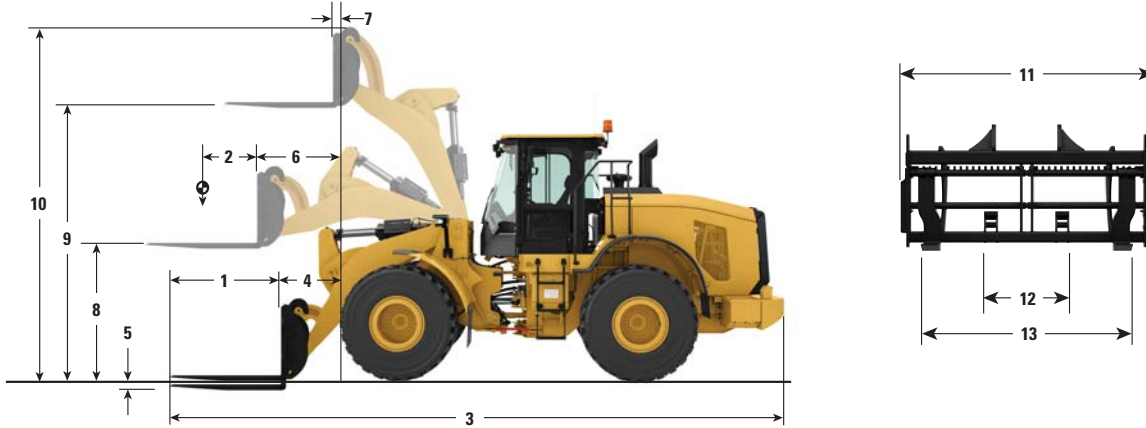

Pallet Fork – Fusion

		48" Tines		60" Tines		72" Tines	
		mm	ft/in	mm	ft/in	mm	ft/in
1	Fork Tine Length	1220	4'0"	1524	5'0"	1830	6'0"
2	Load Center	610	2'0"	762	2'6"	915	3'0"
3	Length: Overall	8531	27'11"	8531	27'11"	9140	29'11"
4	Reach: Ground	1142	3'8"	1142	3'8"	1142	3'8"
5	Dig Depth	-69	-2.7	-69	-2.7	-69	-2.7
6	Reach: Level Arm	1656	5'5"	1656	5'5"	1656	5'5"
7	Reach: Full Lift	734	2'4"	734	2'4"	734	2'4"
8	Clearance: Level Arm	1776	5'9"	1776	5'9"	1776	5'9"
9	Clearance: Full Lift	3895	12'9"	3895	12'9"	3895	12'9"
10	Height: Overall	4964	16'3"	4964	16'3"	4964	16'3"
11	Carriage Width: Overall	2235	7'3"	2235	7'3"	2235	7'3"
12	Minimum Fork Spacing	385	1'3"	385	1'3"	385	1'3"
13	Maximum Fork Spacing	1947	6'4"	1947	6'4"	1947	6'4"
	Tine Width	150	6"	150	6"	150	6"
	Tine Thickness	65	3"	65	3"	65	3"
		kg	lb	kg	lb	kg	lb
	Load Capacity (per pair)	8800	19,395	6590	14,524	5850	12,893
	Tipping Load – Straight*	10 023	22,091	9518	20,978	9057	19,962
	Tipping Load – Full Turn*	8814	19,426	8365	18,436	7954	17,531
	Operating Weight	18 511	40,798	18 549	40,882	18 586	40,964
	Rated Load % of Full Turn Tip:						
	50% of Tip**	4407	9,713	4183	9,219	3977	8,765
	60% of Tip: Rough Terrain***	5289	11,657	5019	11,062	4773	10,520
	80% of Tip: Firm and Level***	7051	15,540	6692	14,749	5851	12,896

*ISO 14397-1

**SAE J1197 – 50% of full turn static tipping load or hydraulic limit.

***EN474-3 – 80% of full turn static tipping load on firm and level ground or hydraulic limit.



WARNING: Do not exceed tine load capacity. Individual tine capacity is stamped on the side of each tine.



WARNING: Exceeding the rated operating load information provided in this document could result in damage to the machine or fork, personal injury, or death.

Pallet and Construction Forks Technical Specifications

950M Operating Specifications

87" Carriage Pallet Fork Operating Specifications

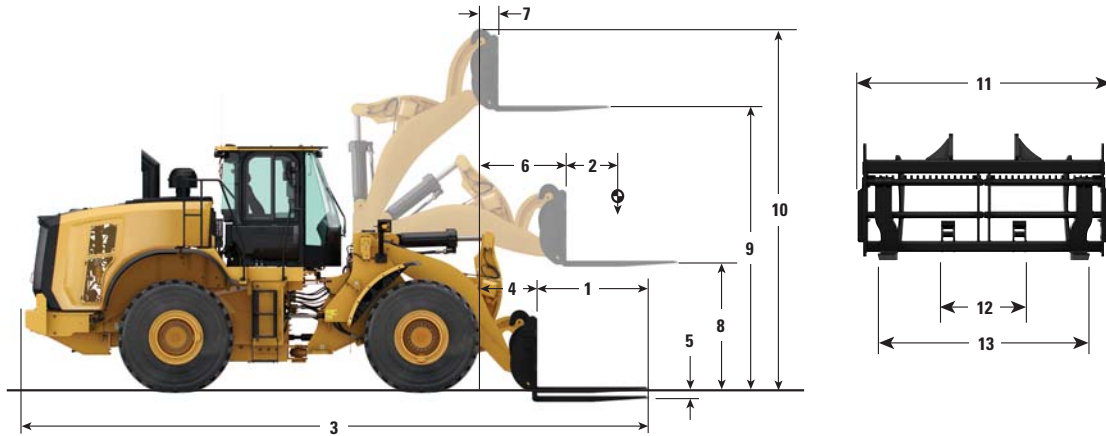

Pallet Fork – Fusion

		48" Tines		60" Tines		72" Tines	
		mm	ft/in	mm	ft/in	mm	ft/in
1	Fork Tine Length	1220	4'0"	1524	5'0"	1830	6'0"
2	Load Center	610	2'0"	762	2'6"	915	3'0"
3	Length: Overall	8438	27'11"	8743	27'11"	9047	29'11"
4	Reach: Ground	1120	3'8"	1120	3'8"	1120	3'8"
5	Dig Depth	-64	-2.7	-64	-2.7	-64	-2.7
6	Reach: Level Arm	1634	5'5"	1634	5'5"	1634	5'5"
7	Reach: Full Lift	919	2'4"	919	2'4"	919	2'4"
8	Clearance: Level Arm	1802	5'9"	1802	5'9"	1802	5'9"
9	Clearance: Full Lift	3737	12'9"	3737	12'9"	3737	12'9"
10	Height: Overall	4805	16'3"	4805	16'3"	4805	16'3"
11	Carriage Width: Overall	2235	7'3"	2235	7'3"	2235	7'3"
12	Minimum Fork Spacing	385	1'3"	385	1'3"	385	1'3"
13	Maximum Fork Spacing	1947	6'4"	1947	6'4"	1947	6'4"
	Tine Width	150	6"	150	6"	150	6"
	Tine Thickness	65	3"	65	3"	65	3"
		kg	lb	kg	lb	kg	lb
	Load Capacity (per pair)	8800	19,395	6590	14,524	5850	12,893
	Tipping Load – Straight*	10 415	22,091	9888	20,978	9405	19,962
	Tipping Load – Full Turn*	9046	19,426	8583	18,436	8160	17,531
	Operating Weight	18 751	40,798	18 789	40,882	18 826	40,964
	Rated Load % of Full Turn Tip:						
	50% of Tip**	4523	9,713	4392	9,219	4080	8,765
	60% of Tip: Rough Terrain***	5428	11,657	5150	11,062	4896	10,520
	80% of Tip: Firm and Level***	7237	15,540	6867	14,749	6528	12,896

*ISO 14397-1

**SAE J1197 – 50% of full turn static tipping load or hydraulic limit.

***EN474-3 – 80% of full turn static tipping load on firm and level ground or hydraulic limit.



WARNING: Do not exceed tine load capacity. Individual tine capacity is stamped on the side of each tine.



WARNING: Exceeding the rated operating load information provided in this document could result in damage to the machine or fork, personal injury, or death.

Pallet and Construction Forks Technical Specifications

962M Operating Specifications

87" Carriage Pallet Fork Operating Specifications

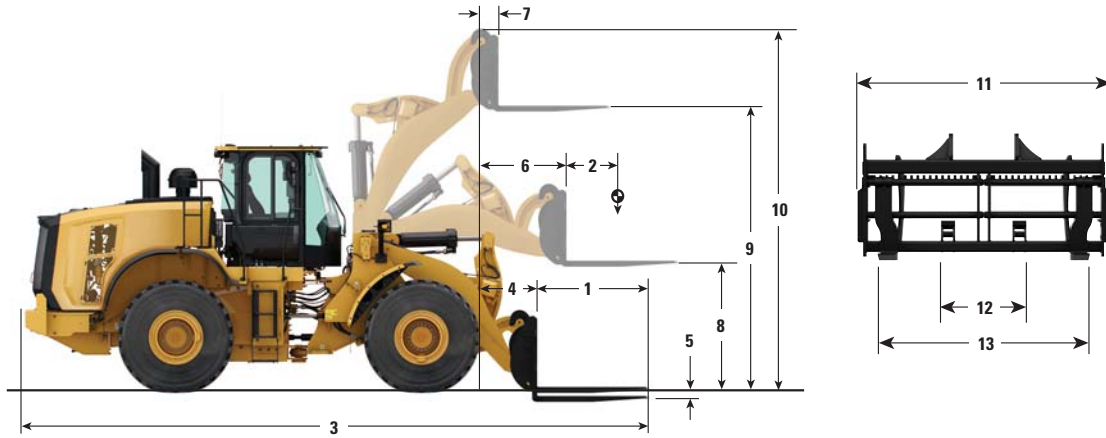

Pallet Fork – Fusion

		48" Tines		60" Tines		72" Tines	
		mm	ft/in	mm	ft/in	mm	ft/in
1	Fork Tine Length	1220	4'0"	1524	5'0"	1830	6'0"
2	Load Center	610	2'0"	762	2'6"	915	3'0"
3	Length: Overall	8760	27'11"	9065	27'11"	9369	29'11"
4	Reach: Ground	1238	3'8"	1238	3'8"	1238	3'8"
5	Dig Depth	-63	-2.7	-63	-2.7	-63	-2.7
6	Reach: Level Arm	1732	5'5"	1732	5'5"	1732	5'5"
7	Reach: Full Lift	853	2'4"	548	2'4"	853	2'4"
8	Clearance: Level Arm	1802	5'9"	1802	5'9"	1802	5'9"
9	Clearance: Full Lift	3954	12'9"	3954	12'9"	3954	12'9"
10	Height: Overall	5022	16'3"	5022	16'3"	5022	16'3"
11	Carriage Width: Overall	2235	7'3"	2235	7'3"	2235	7'3"
12	Minimum Fork Spacing	385	1'3"	385	1'3"	385	1'3"
13	Maximum Fork Spacing	1947	6'4"	1947	6'4"	1947	6'4"
	Tine Width	150	6"	150	6"	150	6"
	Tine Thickness	65	3"	65	3"	65	3"
		kg	lb	kg	lb	kg	lb
	Load Capacity (per pair)	8800	19,395	6590	14,524	5850	12,893
	Tipping Load – Straight*	11 446	22,091	10 886	20,978	10 373	19,962
	Tipping Load – Full Turn*	9883	19,426	9396	18,436	8948	17,531
	Operating Weight	19 695	40,798	19 733	40,882	19 770	40,964
	Rated Load % of Full Turn Tip:						
	50% of Tip**	4942	9,713	4698	9,219	4474	8,765
	60% of Tip: Rough Terrain***	5930	11,657	5637	11,062	5369	10,520
	80% of Tip: Firm and Level***	7907	15,540	7516	14,749	7158	12,896

*ISO 14397-1

**SAE J1197 – 50% of full turn static tipping load or hydraulic limit.

***EN474-3 – 80% of full turn static tipping load on firm and level ground or hydraulic limit.



WARNING: Do not exceed tine load capacity. Individual tine capacity is stamped on the side of each tine.



WARNING: Exceeding the rated operating load information provided in this document could result in damage to the machine or fork, personal injury, or death.

Pallet and Construction Forks Technical Specifications

966M Operating Specifications

87" Carriage Pallet Fork Operating Specifications

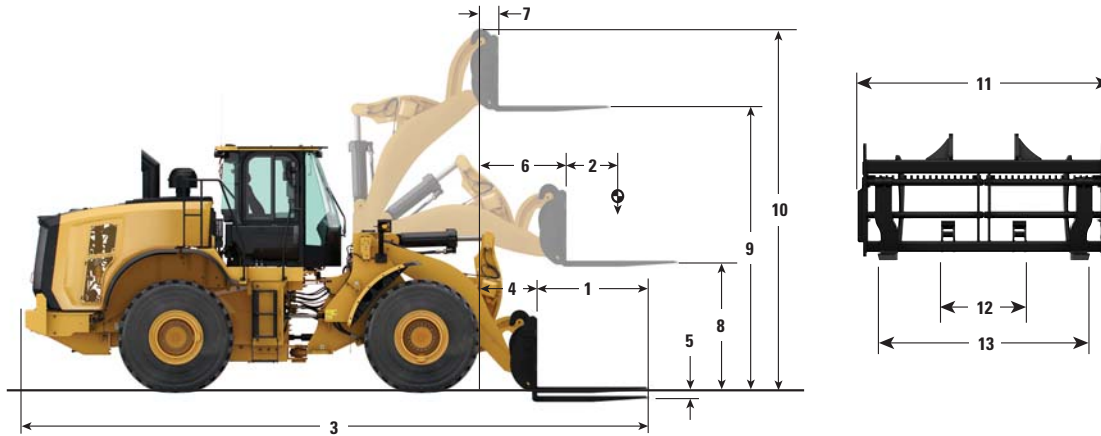

Pallet Fork – Fusion

		48" Tines		60" Tines		72" Tines	
		mm	ft/in	mm	ft/in	mm	ft/in
1	Fork Tine Length	1220	4'0"	1524	5'0"	1830	6'0"
2	Load Center	610	2'0"	762	2'6"	915	3'0"
3	Length: Overall	8827	27'11"	9065	27'11"	9437	29'11"
4	Reach: Ground	1012	3'8"	1238	3'8"	1012	3'8"
5	Dig Depth	-93	-2.7	-93	-2.7	-93	-2.7
6	Reach: Level Arm	1586	5'5"	1281	5'5"	1585	5'5"
7	Reach: Full Lift	718	2'4"	413	2'4"	718	2'4"
8	Clearance: Level Arm	1873	5'9"	1873	5'9"	1873	5'9"
9	Clearance: Full Lift	3957	12'9"	3957	12'9"	3957	12'9"
10	Height: Overall	5025	16'3"	5025	16'3"	5025	16'3"
11	Carriage Width: Overall	2235	7'3"	2235	7'3"	2235	7'3"
12	Minimum Fork Spacing	385	1'3"	385	1'3"	385	1'3"
13	Maximum Fork Spacing	1947	6'4"	1947	6'4"	1947	6'4"
	Tine Width	150	6"	150	6"	150	6"
	Tine Thickness	65	3"	65	3"	65	3"
		kg	lb	kg	lb	kg	lb
	Load Capacity (per pair)	8800	19,395	6590	14,524	5850	12,893
	Tipping Load – Straight*	13 245	22,091	12 761	20,978	12 154	19,962
	Tipping Load – Full Turn*	11 925	19,426	11 332	18,436	10 789	17,531
	Operating Weight	22 096	40,798	22 134	40,882	22 171	40,964
	Rated Load % of Full Turn Tip:						
	50% of Tip**	5963	9,713	5666	9,219	5394	8,765
	60% of Tip: Rough Terrain***	7155	11,657	6799	11,062	6473	10,520
	80% of Tip: Firm and Level***	9540	15,540	9066	14,749	8292	12,896

*ISO 14397-1

**SAE J1197 – 50% of full turn static tipping load or hydraulic limit.

***EN474-3 – 80% of full turn static tipping load on firm and level ground or hydraulic limit.



WARNING: Do not exceed tine load capacity. Individual tine capacity is stamped on the side of each tine.



WARNING: Exceeding the rated operating load information provided in this document could result in damage to the machine or fork, personal injury, or death.

Pallet and Construction Forks Technical Specifications

972M Operating Specifications

87" Carriage Pallet Fork Operating Specifications

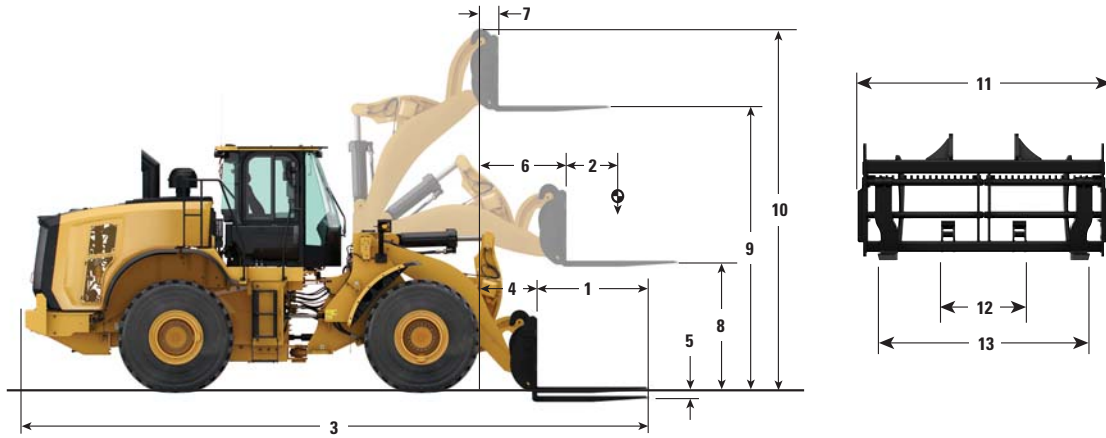

Pallet Fork – Fusion

		48" Tines		60" Tines		72" Tines	
		mm	ft/in	mm	ft/in	mm	ft/in
1	Fork Tine Length	1220	4'0"	1524	5'0"	1830	6'0"
2	Load Center	610	2'0"	762	2'6"	915	3'0"
3	Length: Overall	9306	27'11"	9611	27'11"	9916	29'11"
4	Reach: Ground	1171	3'8"	1238	3'8"	1171	3'8"
5	Dig Depth	-72	-2.7	-72	-2.7	-72	-2.7
6	Reach: Level Arm	1716	5'5"	1411	5'5"	1716	5'5"
7	Reach: Full Lift	671	2'4"	366	2'4"	670	2'4"
8	Clearance: Level Arm	1874	5'9"	1874	5'9"	1874	5'9"
9	Clearance: Full Lift	4180	12'9"	4180	12'9"	4180	12'9"
10	Height: Overall	5249	16'3"	5249	16'3"	5249	16'3"
11	Carriage Width: Overall	2235	7'3"	2235	7'3"	2235	7'3"
12	Minimum Fork Spacing	385	1'3"	385	1'3"	385	1'3"
13	Maximum Fork Spacing	1947	6'4"	1947	6'4"	1947	6'4"
	Tine Width	150	6"	150	6"	150	6"
	Tine Thickness	65	3"	65	3"	65	3"
		kg	lb	kg	lb	kg	lb
	Load Capacity (per pair)	8800	19,395	6590	14,524	5850	12,893
	Tipping Load – Straight*	15 248	22,091	14 527	20,978	13 866	19,962
	Tipping Load – Full Turn*	13 427	19,426	12 789	18,436	12 203	17,531
	Operating Weight	23 791	40,798	23 829	40,882	23 866	40,964
	Rated Load % of Full Turn Tip:						
	50% of Tip**	6714	9,713	6395	9,219	6102	8,765
	60% of Tip: Rough Terrain***	8056	11,657	7673	11,062	7322	10,520
	80% of Tip: Firm and Level***	10 742	15,540	10 231	14,749	9763	12,896

*ISO 14397-1

**SAE J1197 – 50% of full turn static tipping load or hydraulic limit.

***EN474-3 – 80% of full turn static tipping load on firm and level ground or hydraulic limit.



WARNING: Do not exceed tine load capacity. Individual tine capacity is stamped on the side of each tine.



WARNING: Exceeding the rated operating load information provided in this document could result in damage to the machine or fork, personal injury, or death.

Pallet and Construction Forks Technical Specifications

980M Operating Specifications

87" Carriage Pallet Fork Operating Specifications

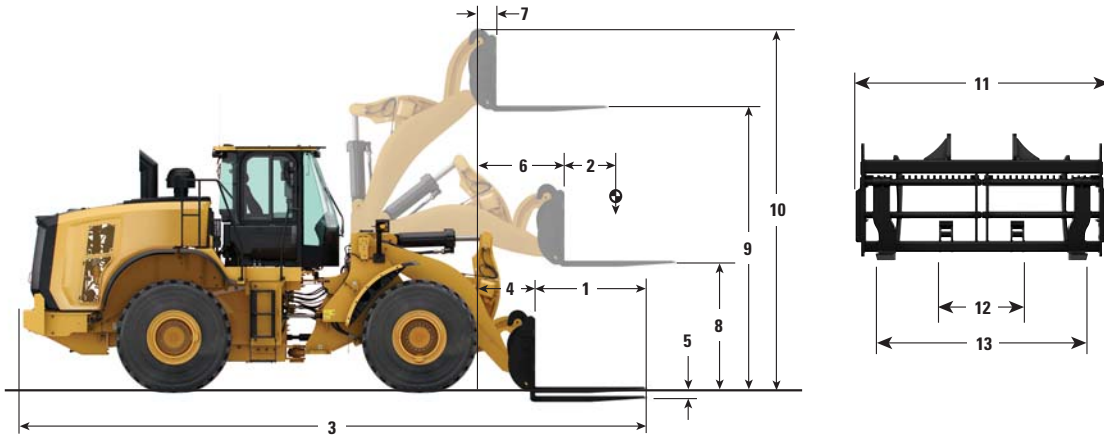

Pallet Fork – Fusion

		48" Tines		60" Tines		72" Tines	
		mm	ft/in	mm	ft/in	mm	ft/in
1	Fork Tine Length	1220	4'0"	1524	5'0"	1830	6'0"
2	Load Center	610	2'0"	762	2'6"	915	3'0"
3	Length: Overall	9551	27'11"	9856	27'11"	10 161	29'11"
4	Reach: Ground	1134	3'8"	1134	3'8"	1134	3'8"
5	Dig Depth	-116	-2.7	-116	-2.7	-116	-2.7
6	Reach: Level Arm	1723	5'5"	1723	5'5"	1723	5'5"
7	Reach: Full Lift	797	2'4"	797	2'4"	796	2'4"
8	Clearance: Level Arm	1993	5'9"	1993	5'9"	1993	5'9"
9	Clearance: Full Lift	4262	12'9"	4262	12'9"	4262	12'9"
10	Height: Overall	5330	16'3"	5330	16'3"	5330	16'3"
11	Carriage Width: Overall	2235	7'3"	2235	7'3"	2235	7'3"
12	Minimum Fork Spacing	385	1'3"	385	1'3"	385	1'3"
13	Maximum Fork Spacing	1947	6'4"	1947	6'4"	1947	6'4"
	Tine Width	150	6"	150	6"	150	6"
	Tine Thickness	65	3"	65	3"	65	3"
		kg	lb	kg	lb	kg	lb
	Load Capacity (per pair)	8800	19,395	6590	14,524	5850	12,893
	Tipping Load – Straight*	17 336	22,091	16 535	20,978	15 800	19,962
	Tipping Load – Full Turn*	15 151	19,426	14 448	18,436	13 802	17,531
	Operating Weight	28 000	40,798	28 038	40,882	28 075	40,964
	Rated Load % of Full Turn Tip:						
	50% of Tip**	7576	9,713	7224	9,219	6901	8,765
	60% of Tip: Rough Terrain***	9091	11,657	8669	11,062	8281	10,520
	80% of Tip: Firm and Level***	11 773	15,540	10 161	14,749	8922	12,896

*ISO 14397-1

**SAE J1197 – 50% of full turn static tipping load or hydraulic limit.

***EN474-3 – 80% of full turn static tipping load on firm and level ground or hydraulic limit.



WARNING: Do not exceed tine load capacity. Individual tine capacity is stamped on the side of each tine.



WARNING: Exceeding the rated operating load information provided in this document could result in damage to the machine or fork, personal injury, or death.

For more complete information on Cat products, dealer services, and industry solutions, visit us on the web at www.cat.com

© 2019 Caterpillar
All rights reserved

Materials and specifications are subject to change without notice. Featured machines in photos may include additional equipment. See your Cat dealer for available options.

CAT, CATERPILLAR, LET'S DO THE WORK, their respective logos, "Caterpillar Yellow", the "Power Edge" and Cat "Modern Hex" trade dress as well as corporate and product identity used herein, are trademarks of Caterpillar and may not be used without permission.

GEJQ9377-01 (05-2019)
Replaces GEJQ9377
(North America)

