



320 GC, GC Narrow

Hydraulic Excavators

Technical Specifications

Configurations and features may vary by region. Please consult your Cat® dealer for availability in your area.

Table of Contents

320 GC Hydraulic Excavator

Specifications	2	Operating Weights and Ground Pressures.....	3
Engine	2	Major Component Weights	3
Swing Mechanism	2	Dimensions.....	4
Weights.....	2	Working Ranges	5
Track	2	Reach Boom Lift Capacities	6
Drive	2	Bucket Specifications and Compatibility	9
Hydraulic System	2	Attachments Offering Guide	13
Service Refill Capacities	2	Standard and Optional Equipment	21
Standards.....	2	Dealer Installed Kit and Attachments	23
Sound Performance	2	320 GC Environmental Declaration	24
Air Conditioning System.....	2		

320 GC Narrow Hydraulic Excavator Specialty Configuration

Key Features and Benefits	25	Sound Performance	27
Specifications	26	Air Conditioning System.....	27
Engine	26	Operating Weights and Ground Pressures.....	28
Swing Mechanism	26	Major Component Weights	28
Weights.....	26	Dimensions.....	29
Track	26	Working Ranges	30
Drive	26	Reach Boom Lift Capacities	31
Standards.....	26	Bucket Specifications and Compatibility	32
Hydraulic System	26	Attachments Offering Guide	36
Service Refill Capacities	27	Standard and Optional Equipment	44
		Dealer Installed Kit and Attachments	46

320 GC Hydraulic Excavator Specifications

Engine

Engine model	Cat® C4.4	
Net Power		
ISO 9249	109 kW	146 hp
ISO 9249 (DIN)	148 hp (metric)	
Engine Power		
ISO 14396	110 kW	148 hp
ISO 14396 (DIN)	150 hp (metric)	
Bore	105 mm	4 in
Stroke	127 mm	5 in
Displacement	4.4 L	269 in ³
Biodiesel Capability	Up to B20 ⁽¹⁾	

- Meets U.S. EPA Tier 4 Final, EU Stage V, and Japan 2014 emission standards.
- Recommended for use up to 4500 m (14,764 ft) altitude with engine power derate above 3000 m (9,842.5 ft).
- Advertised power is tested per the specified standard in effect at the time of manufacture.
- Net power advertised is the power available at the flywheel when the engine is equipped with fan, air intake system, exhaust system and alternator.
- Engine speed at 2,000 rpm.

⁽¹⁾Cat diesel engines are required to use ULSD (ultra-low sulfur diesel fuel with 15 ppm of sulfur or less) or ULSD blended with the following lower-carbon intensity fuels** up to:

- ✓ 20% biodiesel FAME (fatty acid methyl ester)*
- ✓ 100% renewable diesel, HVO (hydrogenated vegetable oil) and GTL (gas-to-liquid) fuels

Refer to guidelines for successful application. Please consult your Cat dealer or “Caterpillar Machine Fluids Recommendations” (SEBU6250) for details.

*Engines with no aftertreatment devices can use higher blends, up to 100% biodiesel (for use of blends higher than 20% biodiesel, consult your Cat dealer).

**Tailpipe greenhouse gas emissions from lower-carbon intensity fuels are essentially the same as traditional fuels.

Swing Mechanism

Swing Speed	11.6 rpm	
Maximum Swing Torque	74.4 kN·m	54,900 lb-ft

Weights

Operating Weight	22 000 kg	48,500 lb
------------------	-----------	-----------

- Long undercarriage, Reach boom, R2.9 (9'6") stick, General Duty (GD) 1.0 m³ (1.31 yd³) bucket, 700 mm (28 in) triple grouser shoes and 4200 kg (9,300 lb) counterweight.

Track

Optional Track Shoes Width	600 mm	24 in
Optional Track Shoes Width	700 mm	28 in
Optional Track Shoes Width	790 mm	31 in
Number of Shoes (each side)	49	
Number of Track Rollers (each side)	8	
Number of Carrier Rollers (each side)	2	

Drive

Gradeability	35°/70%	
Maximum Travel Speed	5.9 km/h	3.6 mph
Maximum Drawbar Pull	200 kN	45,000 lbf

Hydraulic System

Main System – Maximum Flow – Implement	442 L/min (221 × 2 pumps)	117 gal/min (58.5 × 2 pumps)
Maximum Pressure – Equipment – Normal	35 000 kPa	5,075 psi
Maximum Pressure – Travel	34 300 kPa	4,974 psi
Maximum Pressure – Swing	25,000 kPa	3,625 psi
Boom Cylinder – Bore	120 mm	5 in
Boom Cylinder – Stroke	1260 mm	50 in
Stick Cylinder – Bore	135 mm	5 in
Stick Cylinder – Stroke	1504 mm	59 in
Bucket Cylinder – Bore	115 mm	5 in
Bucket Cylinder – Stroke	1104 mm	43 in

Service Refill Capacities

Fuel Tank Capacity	345 L	86.6 gal
Cooling System	25 L	6.6 gal
Engine Oil	15 L	4.0 gal
Swing Drive	12 L	3.2 gal
Final Drive (each)	4 L	1.1 gal
Hydraulic System (including tank)	234 L	61.8 gal
Hydraulic Tank	115 L	30.4 gal
Diesel Exhaust Fluid (DEF) Tank	39 L	10.3 gal

Standards

Brakes	ISO 10265:2008
Cab/Rollover Protective Structure (ROPS)	ISO 12117-2:2008
Operator Protective Guards (OPG)	ISO 10262:1998 Level II (optional)

Sound Performance

ISO 6395:2008 (external)	101 dB(A)
ISO 6396:2008 (inside cab)	70 dB(A)

- Hearing protection may be needed when operating with an open operator station and cab (when not properly maintained or doors/windows open) for extended periods or in a noisy environment.

Air Conditioning System

The air conditioning system on this machine contains the fluorinated greenhouse gas refrigerant R134a (Global Warming Potential = 1430). The system contains 0.85 kg (1.9 lb) of refrigerant which has a CO₂ equivalent of 1.216 metric tonnes (1.340 tons).

320 GC Hydraulic Excavator Specifications

Operating Weights and Ground Pressures

Base Machine Configurations	600 mm (24 in) Triple Grouser Shoes		700 mm (28 in) Triple Grouser Shoes		790 mm (31 in) Triple Grouser Shoes		900 mm (35 in) Triple Grouser Shoes		
	Weight	Ground Pressure	Weight	Ground Pressure	Weight	Ground Pressure	Weight	Ground Pressure	
	kg (lb)	kPa (psi)	kg (lb)	kPa (psi)	kg (lb)	kPa (psi)	kg (lb)	kPa (psi)	
Base Frame with Track Rollers and Carrier Rollers									
4.2 mt (9,300 lb) Counterweight + Long Undercarriage Base Machine									
Reach Boom + R2.9 (9'6") Stick + 1.0 m ³ (1.31 yd ³) GD Bucket	21 600 (47,600)	44.9 (6.5)	22 000 (48,500)	39.2 (5.7)	22 200 (49,000)	35.1 (5.1)	22 500 (49,600)	31.2 (4.5)	

All operating weights include a 90% fuel tank with 75 kg (165 lb) operator.

Major Component Weights

	kg	lb
Base Machine Weight (with 4.2 mt [9,300 lb] counterweight, upper frame, long undercarriage with track rollers – does not include boom cylinders, boom, stick, bucket, stick cylinder, bucket cylinder, tracks, 90% fuel tank and 75 kg [165 lb] operator).	14 800	32,600
Track Shoes:		
600 mm (24 in) Width, 8.5 mm (0.33") Thick Triple Grouser Track Shoes	2600	5,700
700 mm (28 in) Width, 10 mm (0.39") Thick Triple Grouser Track Shoes	3020	6,700
790 mm (31 in) Width, 10 mm (0.39") Thick Triple Grouser Track Shoes with Step Extension	3290	7,300
900 mm (35 in) Width, 10 mm (0.39") Thick Triple Grouser Track Shoes with Step Extension	3570	7,900
Two Boom Cylinders	340	700
Weight of 90% Fuel Tank and 75 kg (165 lb) Operator	310	700
Counterweight:		
4.2 mt (9,300 lb) Counterweight	4200	9,300
Swing Frame:		
Swing Frame	1910	4,200
Undercarriage:		
Standard Base Frame with Heavy Duty (HD) Track Rollers and Standard Carrier Rollers for Long Undercarriage	4390	9,700
Boom (including lines, pins, stick cylinder):		
Reach Boom 5.7 m (18'8")	1690	3,700
Sticks (including lines, pins, bucket cylinder, bucket linkage):		
Reach Stick R2.5 (8'2")	1020	2,200
Reach Stick R2.9 (9'6")	1080	2,400
Bucket (without linkage):		
1.0 m ³ (1.31 yd ³) GD	735	1,600
Quick Couplers (QC):		
CW Dedicated QC	230	500
Pin Grabber QC	390	900

320 GC Hydraulic Excavator Specifications

Dimensions

All dimensions are approximate and may vary depending on bucket selection.

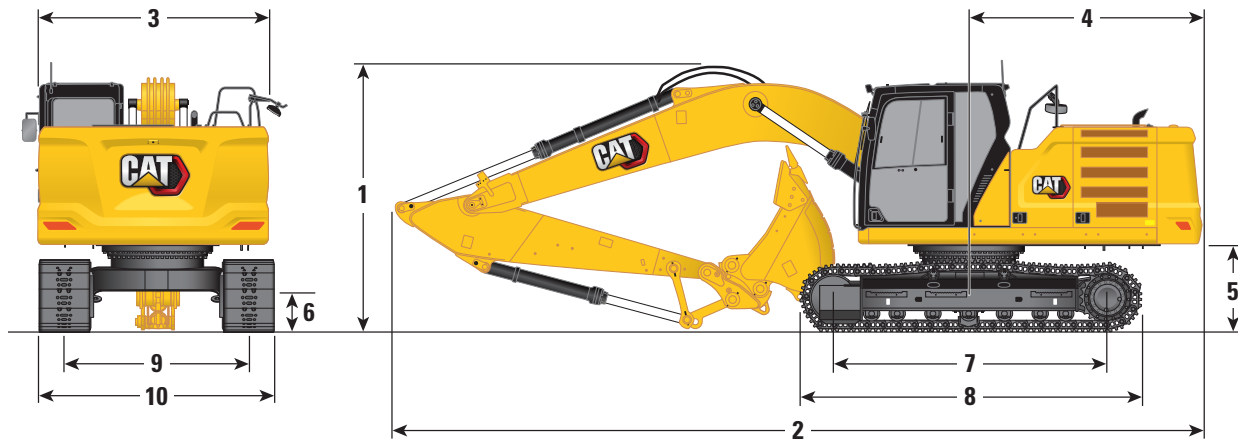

Boom Option

Reach Boom 5.7 m (18'8")

Stick Options

Reach Stick R2.9B1 (9'6")

Reach Stick R2.5B1 (8'2")

		Reach Stick R2.9B1 (9'6")	Reach Stick R2.5B1 (8'2")
1 Machine Height:			
Top of Cab Height	2960 mm	9'8"	2960 mm 9'8"
Top of OPG Height	3100 mm	10'2"	3100 mm 10'2"
Handrail Height	2950 mm	9'8"	2950 mm 9'8"
With Boom/Stick/Bucket Installed	3160 mm	10'4"	3080 mm 10'1"
With Boom/Stick Installed	2910 mm	9'6"	2830 mm 9'3"
With Boom Installed	2480 mm	8'1"	2480 mm 8'1"
2 Machine Length:			
With Boom/Stick/Bucket Installed	9530 mm	31'3"	9530 mm 31'3"
With Boom/Stick Installed	9500 mm	31'1"	9480 mm 31'1"
With Boom Installed	8450 mm	27'8"	8450 mm 27'8"
3 Upperframe Width	2780 mm	9'1"	2780 mm 9'1"
4 Tail Swing Radius	2830 mm	9'3"	2830 mm 9'3"
5 Counterweight Clearance	1050 mm	3'5"	1050 mm 3'5"
6 Ground Clearance	470 mm	1'6"	470 mm 1'6"
7 Length to Center of Rollers	3650 mm	11'11"	3650 mm 11'11"
8 Track Length	4450 mm	14'7"	4450 mm 14'7"
9 Track Gauge	2380 mm	7'9"	2380 mm 7'9"
10 Undercarriage Width:			
600 mm (24 in) Shoes	2980 mm	9'9"	2980 mm 9'9"
700 mm (28 in) Shoes	3080 mm	10'1"	3080 mm 10'1"
790 mm (31 in) Shoes	3170 mm	10'4"	3170 mm 10'4"
900 mm (35 in) Shoes	3280 mm	10'9"	3280 mm 10'9"
Bucket Type		GD	GD
Bucket Capacity	1.0 m ³	1.31 yd ³	1.0 m ³ 1.31 yd ³
Bucket Tip Radius	1570 mm	5'1"	1570 mm 5'1"

320 GC Hydraulic Excavator Specifications

Working Ranges

All dimensions are approximate and may vary depending on bucket selection.

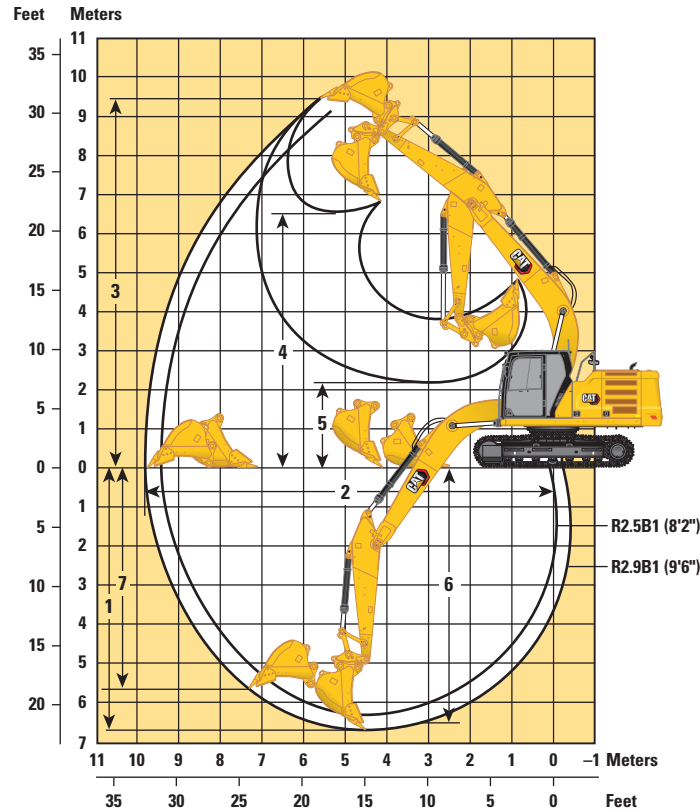

Boom Option	Reach Boom 5.7 m (18'8")			
Stick Options	Reach Stick R2.9B1 (9'6")		Reach Stick R2.5B1 (8'2")	
1 Maximum Digging Depth	6720 mm	22'0"	6300 mm	20'8"
2 Maximum Reach at Ground Line	9860 mm	32'4"	9470 mm	31'0"
3 Maximum Cutting Height	9450 mm	31'0"	9250 mm	30'4"
4 Maximum Loading Height	6490 mm	21'3"	6290 mm	20'7"
5 Minimum Loading Height	2170 mm	7'1"	2590 mm	8'5"
6 Maximum Depth Cut for 2440 mm (8'0") Level Bottom	6550 mm	21'5"	6110 mm	20'0"
7 Maximum Vertical Wall Digging Depth	5690 mm	18'8"	5290 mm	17'4"
Bucket Digging Force (ISO)	129 kN	28,935 lbf	129 kN	28,935 lbf
Stick Digging Force (ISO)	99 kN	22,281 lbf	110 kN	24,688 lbf
Bucket Type	GD		GD	
Bucket Capacity	1.0 m ³	1.31 yd ³	1.0 m ³	1.31 yd ³
Bucket Tip Radius	1570 mm	5'1"	1570 mm	5'1"

320 GC Hydraulic Excavator Specifications

Reach Boom Lift Capacities – Counterweight: 4.2 mt (9,300 lb) – without Bucket

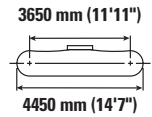
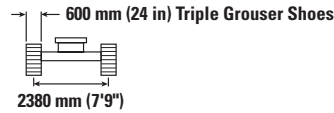
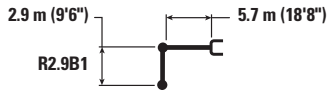

		1500 mm/60 in		3000 mm/120 in		4500 mm/180 in		6000 mm/240 in		7500 mm/300 in		mm in		
7500 mm 300 in	kg lb							*4350	*4350			*3750 *8,350	*3750 *8,350	6150 240
6000 mm 240 in	kg lb							*4950 *10,900	*4950 *10,900			*3500 *7,650	*3500 *7,650	7290 290
4500 mm 180 in	kg lb							*5450 *11,850	5300 11,450	*5150 *10,950	3800 8,100	*3400 *7,500	*3400 *7,500	7990 320
3000 mm 120 in	kg lb					*7950 *17,150	7750 16,700	*6250 *13,600	5100 10,950	*5450 *11,900	3700 7,900	*3500 *7,650	3100 6,850	8360 330
1500 mm 60 in	kg lb					*9650 *20,800	7250 15,650	*7100 *15,400	4850 10,500	5550 11,900	3550 7,650	*3700 *8,100	3000 6,600	8450 340
0 mm 0 in	kg lb			*5800 *13,250	*5800 *13,250	*10 600 *22,900	7000 15,050	7500 16,150	4700 10,150	5450 11,700	3500 7,500	*4100 *9,000	3050 6,750	8260 330
-1500 mm -60 in	kg lb	*6150 *13,800	*6150 *13,800	*10 000 *22,700	*10 000 *22,700	*10 700 *23,150	6900 14,850	7450 16,000	4650 10,000	5400 11,650	3450 7,450	*4800 *10,600	3300 7,250	7780 310
-3000 mm -120 in	kg lb	*10 600 *23,800	*10 600 *23,800	*14 150 *30,650	13 450 28,750	*10 000 *21,600	6950 15,000	*7450 *15,950	4650 10,050			6100 *13,400	3850 8,550	6950 280
-4500 mm -180 in	kg lb			*11 300 *24,200	*11 300 *24,200	*8150 *17,300	7150 15,450					*6150 *13,500	5300 11,950	5600 220

Reach Boom Lift Capacities – Counterweight: 4.2 mt (9,300 lb) – without Bucket

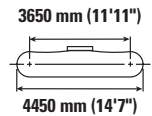
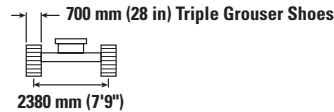
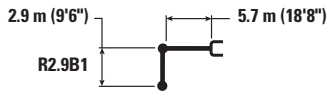

		1500 mm/60 in		3000 mm/120 in		4500 mm/180 in		6000 mm/240 in		7500 mm/300 in		mm in		
7500 mm 300 in	kg lb							*4350	*4350			*3750 *8,350	*3750 *8,350	6150 240
6000 mm 240 in	kg lb							*4950 *10,900	*4950 *10,900			*3500 *7,650	*3500 *7,650	7290 290
4500 mm 180 in	kg lb							*5450 *11,850	5350 11,550	*5150 *10,950	3800 8,150	*3400 *7,500	*3400 *7,500	7990 320
3000 mm 120 in	kg lb					*7950 *17,150	7800 16,850	*6250 *13,600	5150 11,050	*5450 *11,900	3700 8,000	*3500 *7,650	3150 6,950	8360 330
1500 mm 60 in	kg lb					*9650 *20,800	7350 15,800	*7100 *15,400	4900 10,600	5600 12,000	3600 7,750	*3700 *8,100	3050 6,700	8450 340
0 mm 0 in	kg lb			*5800 *13,250	*5800 *13,250	*10 600 *22,900	7050 15,200	7600 16,300	4750 10,250	5500 11,800	3500 7,550	*4100 *9,000	3100 6,800	8260 330
-1500 mm -60 in	kg lb	*6150 *13,800	*6150 *13,800	*10 000 *22,700	*10 000 *22,700	*10 700 *23,150	7000 15,000	7500 16,150	4700 10,050	5450 11,750	3500 7,500	*4800 *10,600	3350 7,350	7780 310
-3000 mm -120 in	kg lb	*10 600 *23,800	*10 600 *23,800	*14 150 *30,650	13 550 29,000	*10 000 *21,600	7050 15,150	*7450 *15,950	4700 10,150			6100 *13,400	3900 8,650	6950 280
-4500 mm -180 in	kg lb			*11 300 *24,200	*11 300 *24,200	*8150 *17,300	7250 15,600					*6150 *13,500	5350 12,050	5600 220



ISO 10567:2007



* Indicates that the load is limited by hydraulic lifting capacity rather than tipping load. The above loads are in compliance with hydraulic excavator lift capacity standard ISO 10567:2007. They do not exceed 87% of hydraulic lifting capacity or 75% of tipping load. Weight of all lifting accessories must be deducted from the above lifting capacities. Lifting capacities are based on the machine standing on a firm, uniform supporting surface. The use of a work tool attachment point to handle/lift objects, could affect the machine lift performance.

Lift capacity stays with ±5% for all available track shoes.

Always refer to the appropriate Operation and Maintenance Manual for specific product information.

320 GC Hydraulic Excavator Specifications

Reach Boom Lift Capacities – Counterweight: 4.2 mt (9,300 lb) – without Bucket

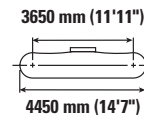
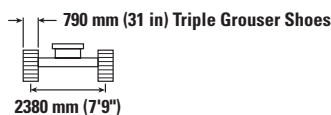
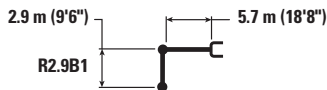

		1500 mm/60 in		3000 mm/120 in		4500 mm/180 in		6000 mm/240 in		7500 mm/300 in		mm in		
7500 mm 300 in	kg lb							*4350	*4350			*3750 *8,350	*3750 *8,350	6150 240
6000 mm 240 in	kg lb							*4950 *10,900	*4950 *10,900			*3500 *7,650	*3500 *7,650	7290 290
4500 mm 180 in	kg lb							*5450 *11,850	5450 11,700	*5150 *10,950	3850 8,250	*3400 *7,500	*3400 *7,500	7990 320
3000 mm 120 in	kg lb					*7950 *17,150	7900 17,000	*6250 *13,600	5200 11,200	*5450 *11,900	3750 8,100	*3500 *7,650	3200 7,050	8360 330
1500 mm 60 in	kg lb					*9650 *20,800	7400 16,000	*7100 *15,400	5000 10,700	5650 12,150	3650 7,850	*3700 *8,100	3100 6,800	8450 340
0 mm 0 in	kg lb			*5800 *13,250	*5800 *13,250	*10 600 *22,900	7150 15,400	7700 16,550	4800 10,350	5550 11,950	3550 7,650	*4100 *9,000	3150 6,900	8260 330
-1500 mm -60 in	kg lb	*6150 *13,800	*6150 *13,800	*10 000 *22,700	*10 000 *22,700	*10 700 *23,150	7050 15,200	7600 16,350	4750 10,200	5550 11,900	3550 7,650	*4800 *10,600	3400 7,450	7780 310
-3000 mm -120 in	kg lb	*10 600 *23,800	*10 600 *23,800	*14 150 *30,650	13 700 29,400	*10 000 *21,600	7150 15,350	*7450 *15,950	4750 10,300			*6100 *13,400	3950 8,750	6950 280
-4500 mm -180 in	kg lb			*11 300 *24,200	*11 300 *24,200	*8150 *17,300	7300 15,800					*6150 *13,500	5450 12,200	5600 220

Reach Boom Lift Capacities – Counterweight: 4.2 mt (9,300 lb) – without Bucket

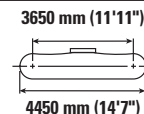
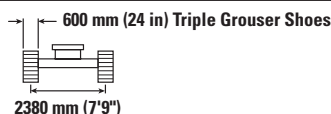
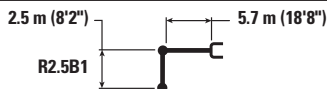

		3000 mm/120 in		4500 mm/180 in		6000 mm/240 in		7500 mm/300 in		mm in		
7500 mm 300 in	kg lb									*4550 *10,100	*4550 *10,100	5600 220
6000 mm 240 in	kg lb					*5400 *11,800	*5400 11,600			*4150 *9,150	*4150 *9,150	6830 270
4500 mm 180 in	kg lb			*6750 *14,600	*6750 *14,600	*5800 *12,650	5250 11,350	*4600 *10,950	3750 8,250	*4050 *8,950	3700 8,150	7570 300
3000 mm 120 in	kg lb			*8500 *18,350	7600 16,450	*6600 *14,250	5050 10,850	5600 12,050	3650 7,850	*4150 *9,150	3350 7,350	7960 320
1500 mm 60 in	kg lb			*10 050 *21,700	7200 15,500	*7350 *15,900	4850 10,450	5500 11,850	3550 7,650	*4450 *9,750	3250 7,100	8050 320
0 mm 0 in	kg lb			*10 750 *23,200	7000 15,000	7500 16,150	4700 10,150	5450 11,700	3500 7,500	*4950 *10,950	3300 7,250	7860 310
-1500 mm -60 in	kg lb	*10 550 *23,950	*10 550 *23,950	*10 600 *22,950	6950 14,950	7450 16,050	4650 10,050			5600 12,350	3600 7,900	7350 290
-3000 mm -120 in	kg lb	*13 300 *28,800	*13 300 *28,800	*9650 *20,800	7050 15,150	*7100 *15,250	4700 10,200			*6400 *14,050	4300 9,550	6470 260
-4500 mm -180 in	kg lb			*7200 *15,100	*7200 *15,100					*6250 *13,650	*6250 *13,650	4980 200



ISO 10567:2007



* Indicates that the load is limited by hydraulic lifting capacity rather than tipping load. The above loads are in compliance with hydraulic excavator lift capacity standard ISO 10567:2007. They do not exceed 87% of hydraulic lifting capacity or 75% of tipping load. Weight of all lifting accessories must be deducted from the above lifting capacities. Lifting capacities are based on the machine standing on a firm, uniform supporting surface. The use of a work tool attachment point to handle/lift objects, could affect the machine lift performance.









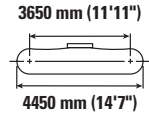
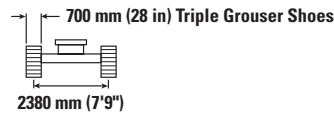
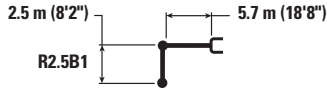

Lift capacity stays with ±5% for all available track shoes.

Always refer to the appropriate Operation and Maintenance Manual for specific product information.

320 GC Hydraulic Excavator Specifications









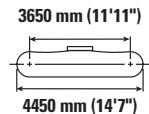
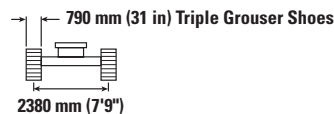
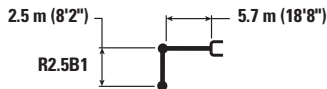

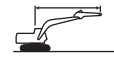
Reach Boom Lift Capacities – Counterweight: 4.2 mt (9,300 lb) – without Bucket



		3000 mm/120 in		4500 mm/180 in		6000 mm/240 in		7500 mm/300 in				mm in
												
7500 mm 300 in	kg lb									*4550 *10,100	*4550 *10,100	5600 220
6000 mm 240 in	kg lb					*5400 *11,800	*5400 11,700			*4150 *9,150	*4150 *9,150	6830 270
4500 mm 180 in	kg lb			*6750 *14,600	*6750 *14,600	*5800 *12,650	5300 11,450	*4600	3750	*4050 *8,950	3700 8,200	7570 300
3000 mm 120 in	kg lb			*8500 *18,350	7700 16,550	*6600 *14,250	5100 10,950	5700 12,200	3700 7,950	*4150 *9,150	3400 7,450	7960 320
1500 mm 60 in	kg lb			*10 050 *21,700	7250 15,600	*7350 *15,900	4900 10,500	5550 12,000	3600 7,750	*4450 *9,750	3250 7,150	8050 320
0 mm 0 in	kg lb			*10 750 *23,200	7050 15,150	*7600 16,300	4750 10,200	5500 11,850	3550 7,600	*4950 *10,950	3350 7,300	7860 310
-1500 mm -60 in	kg lb	*10 550 *23,950	*10 550 *23,950	*10 600 *22,950	7000 15,100	7550 16,200	4700 10,150			5650 12,450	3600 8,000	7350 290
-3000 mm -120 in	kg lb	*13 300 *28,800	*13 300 *28,800	*9650 *20,800	7100 15,250	*7100 *15,250	4750 10,300			*6400 *14,050	4350 9,650	6470 260
-4500 mm -180 in	kg lb			*7200 *15,100	*7200 *15,100					*6250 *13,650	*6250 *13,650	4980 200

Reach Boom Lift Capacities – Counterweight: 4.2 mt (9,300 lb) – without Bucket



		3000 mm/120 in		4500 mm/180 in		6000 mm/240 in		7500 mm/300 in				mm in
												
7500 mm 300 in	kg lb									*4550 *10,100	*4550 *10,100	5600 220
6000 mm 240 in	kg lb					*5400 *11,800	*5400 *11,800			*4150 *9,150	*4150 *9,150	6830 270
4500 mm 180 in	kg lb			*6750 *14,600	*6750 *14,600	*5800 *12,650	5400 11,550	*4600	3800	*4050 *8,950	3750 8,300	7570 300
3000 mm 120 in	kg lb			*8500 *18,350	7800 16,750	*6600 *14,250	5150 11,100	*5700 12,350	3750 8,050	*4150 *9,150	3400 7,550	7960 320
1500 mm 60 in	kg lb			*10 050 *21,700	7350 15,800	*7350 *15,900	4950 10,650	5650 12,150	3650 7,850	*4450 *9,750	3300 7,250	8050 320
0 mm 0 in	kg lb			*10 750 *23,200	7150 15,350	7700 16,500	4800 10,350	5550 12,000	3600 7,700	*4950 *10,950	3350 7,400	7860 310
-1500 mm -60 in	kg lb	*10 550 *23,950	*10 550 *23,950	*10 600 *22,950	7100 15,300	7650 16,400	4750 10,250			5750 12,650	3650 8,100	7350 290
-3000 mm -120 in	kg lb	*13 300 *28,800	*13 300 *28,800	*9650 *20,800	7200 15,450	*7100 *15,250	4850 10,400			*6400 *14,050	4400 9,750	6470 260
-4500 mm -180 in	kg lb			*7200 *15,100	*7200 *15,100					*6250 *13,650	*6250 *13,650	4980 200



ISO 10567:2007



* Indicates that the load is limited by hydraulic lifting capacity rather than tipping load. The above loads are in compliance with hydraulic excavator lift capacity standard ISO 10567:2007. They do not exceed 87% of hydraulic lifting capacity or 75% of tipping load. Weight of all lifting accessories must be deducted from the above lifting capacities. Lifting capacities are based on the machine standing on a firm, uniform supporting surface. The use of a work tool attachment point to handle/lift objects, could affect the machine lift performance.

Lift capacity stays with ±5% for all available track shoes.

Always refer to the appropriate Operation and Maintenance Manual for specific product information.

320 GC Hydraulic Excavator Specifications

Bucket Specifications and Compatibility

	Linkage	Width		Capacity		Weight		Fill %	Long Undercarriage	
		mm	in	m ³	yd ³	kg	lb		4.2 mt (9,300 lb) Counterweight	
									Reach Boom	
									R2.5 (8'2")	R2.9 (9'6")
Pin-On (No Quick Coupler)										
General Duty	B	600	24	0.46	0.61	555	1,223	100	●	●
	B	750	30	0.64	0.84	626	1,380	100	●	●
	B	1200	48	1.19	1.56	812	1,789	100	●	⊙
	B	1300	51	1.30	1.70	835	1,841	100	●	⊙
	B	1400	55	1.43	1.87	879	1,937	100	X	X
General Duty	B	600	24	0.46	0.60	550	1,212	100	●	●
	B	750	30	0.64	0.84	621	1,368	100	●	●
	B	1000	39	0.93	1.22	717	1,580	100	●	●
	B	1200	48	1.19	1.56	807	1,778	100	●	⊙
	B	1400	55	1.43	1.87	874	1,926	100	X	X
	B	1500	60	1.58	2.06	914	2,014	100	X	X
	B	1050	42	1.00	1.31	892	1,967	100	●	●
	B	1200	48	1.19	1.56	917	2,022	100	●	⊙
	B	1300	52	1.30	1.70	974	2,148	100	⊙	⊖
	B	1050	42	1.00	1.31	948	2,091	90	●	●
Severe Duty	B	1200	48	1.20	1.57	1011	2,229	90	●	●
	B	2000	78	1.22	1.60	869	1,916	100	●	⊙
	B	2000	79	1.23	1.61	1096	2,417	100	⊙	⊖
General Duty	312	900	36	0.53	0.69	403	888	100		
Ditch Cleaning Long Reach	312	1200	48	0.57	0.74	386	851	100		
								kg	3440	3180
								lb	7,584	7,011

The above loads are in compliance with hydraulic excavator standard EN474-5:2006+A3:2013, they do not exceed 87% of hydraulic lifting capacity or 75% of tipping capacity with front linkage fully extended at ground line with bucket curled.

Capacity based on ISO 7451:2007.

Bucket weight with General Duty tips.

Maximum Material Density:

- 2100 kg/m³ (3,500 lb/yd³)
- ⊙ 1800 kg/m³ (3,000 lb/yd³)
- ⊖ 1500 kg/m³ (2,500 lb/yd³)
- X Not Recommended

Caterpillar recommends using appropriate work tools to maximize the value customers receive from our products. Use of work tools, including buckets, which are outside of Caterpillar's recommendations or specifications for weight, dimensions, flows, pressures, etc. may result in less-than-optimal performance, including but not limited to reductions in production, stability, reliability, and component durability. Improper use of a work tool resulting in sweeping, prying, twisting and/or catching of heavy loads will reduce the life of the boom and stick.

(continued on next page)

320 GC Hydraulic Excavator Specifications

Bucket Specifications and Compatibility *(continued)*

	Linkage	Width		Capacity		Weight		Fill	Long Undercarriage		
		mm	in	m ³	yd ³	kg	lb		%	4.2 mt (9,300 lb) Counterweight	
										Reach Boom	
									R2.5 (8'2")	R2.9 (9'6")	
With Cat Pin Grabber Coupler											
General Duty	B	600	24	0.46	0.61	555	1,223	100	●	●	
	B	750	30	0.64	0.84	626	1,380	100	●	●	
	B	1200	48	1.19	1.56	812	1,789	100	⊙	⊖	
	B	1300	51	1.30	1.70	835	1,841	100	⊖	⊖	
	B	1400	55	1.43	1.87	879	1,937	100	⊖	○	
General Duty	B	600	24	0.46	0.60	550	1,212	100	●	●	
	B	750	30	0.64	0.84	621	1,368	100	●	●	
	B	1000	39	0.93	1.22	717	1,580	100	●	●	
	B	1200	48	1.19	1.56	807	1,778	100	⊙	⊖	
	B	1400	55	1.43	1.87	874	1,926	100	⊖	○	
	B	1500	60	1.58	2.06	914	2,014	100	○	○	
	B	1050	42	1.00	1.31	892	1,967	100	●	⊙	
	B	1200	48	1.19	1.56	917	2,022	100	⊙	⊖	
	B	1300	52	1.30	1.70	974	2,148	100	⊖	○	
	B	1050	42	1.00	1.31	948	2,091	90	●	●	
Severe Duty	B	1200	48	1.20	1.57	1011	2,229	90	⊙	⊖	
	B	2000	78	1.22	1.60	869	1,916	100	⊙	⊖	
	B	2000	79	1.23	1.61	1096	2,417	100	⊖	○	
								kg	3019	2760	
								lb	6,657	6,086	

The above loads are in compliance with hydraulic excavator standard EN474-5:2006+A3:2013, they do not exceed 87% of hydraulic lifting capacity or 75% of tipping capacity with front linkage fully extended at ground line with bucket curled.

Capacity based on ISO 7451:2007.

Bucket weight with General Duty tips.

Maximum Material Density:

- 2100 kg/m³ (3,500 lb/yd³)
- ⊙ 1800 kg/m³ (3,000 lb/yd³)
- ⊖ 1500 kg/m³ (2,500 lb/yd³)
- 1200 kg/m³ (2,000 lb/yd³)

Caterpillar recommends using appropriate work tools to maximize the value customers receive from our products. Use of work tools, including buckets, which are outside of Caterpillar's recommendations or specifications for weight, dimensions, flows, pressures, etc. may result in less-than-optimal performance, including but not limited to reductions in production, stability, reliability, and component durability. Improper use of a work tool resulting in sweeping, prying, twisting and/or catching of heavy loads will reduce the life of the boom and stick.

(continued on next page)

320 GC Hydraulic Excavator Specifications

Bucket Specifications and Compatibility (continued)

	Linkage	Width		Capacity		Weight		Fill %	Long Undercarriage 4.2 mt (9,300 lb) Counterweight	
		mm	in	m ³	yd ³	kg	lb		Reach Boom	
									R2.5 (8'2")	R2.9 (9'6")
With CW-40 Quick Coupler										
General Duty	B	900	36	0.81	1.06	664	1,463	100	●	●
	B	1050	42	1.00	1.31	711	1,567	100	●	●
	B	1200	48	1.19	1.56	781	1,721	100	●	⊙
	B	1300	51	1.30	1.70	813	1,791	100	⊙	⊖
Heavy Duty	B	600	24	0.46	0.61	618	1,363	100	●	●
	B	1200	48	1.19	1.56	886	1,953	100	⊙	⊙
	B	1300	52	1.30	1.71	944	2,081	100	X	X
Ditch Cleaning	B	2100	83	1.29	1.69	792	1,746	100	⊙	⊖
	B	2100	83	1.46	1.91	809	1,784	100	⊖	⊖
	B	1800	72	1.50	1.96	775	1,709	100	⊖	⊖
	B	1800	72	1.50	1.96	737	1,624	100	⊖	⊖
Ditch Cleaning – Tilt	B	2000	79	1.23	1.61	1161	2,560	100	⊖	⊖
								kg	3191	2932
								lb	7,035	6,464
With CW-40S Quick Coupler										
General Duty	B	600	24	0.46	0.61	508	1,119	100	●	●
	B	750	30	0.64	0.84	592	1,305	100	●	●
	B	900	36	0.81	1.06	661	1,457	100	●	●
	B	1300	51	1.30	1.70	810	1,785	100	⊙	⊖
	B	1400	55	1.43	1.87	845	1,862	100	⊖	⊖
Heavy Duty	B	600	24	0.46	0.61	585	1,289	100	●	●
	B	1200	48	1.19	1.56	875	1,928	100	⊙	⊙
	B	1300	52	1.30	1.70	931	2,052	100	X	X
Ditch Cleaning	B	2000	78	1.22	1.60	815	1,797	100	⊙	⊙
	B	2200	87	1.36	1.78	880	1,940	100	⊙	⊖
Ditch Cleaning – Tilt	B	2000	79	1.23	1.61	1142	2,518	100	⊖	⊖
								kg	3209	2949
								lb	7,075	6,501

The above loads are in compliance with hydraulic excavator standard EN474-5:2006+A3:2013, they do not exceed 87% of hydraulic lifting capacity or 75% of tipping capacity with front linkage fully extended at ground line with bucket curled.

Capacity based on ISO 7451:2007.

Bucket weight with General Duty tips.

Maximum Material Density:

- 2100 kg/m³ (3,500 lb/yd³)
- ⊙ 1800 kg/m³ (3,000 lb/yd³)
- ⊖ 1500 kg/m³ (2,500 lb/yd³)
- 1200 kg/m³ (2,000 lb/yd³)
- X Not Recommended

Caterpillar recommends using appropriate work tools to maximize the value customers receive from our products. Use of work tools, including buckets, which are outside of Caterpillar's recommendations or specifications for weight, dimensions, flows, pressures, etc. may result in less-than-optimal performance, including but not limited to reductions in production, stability, reliability, and component durability. Improper use of a work tool resulting in sweeping, prying, twisting and/or catching of heavy loads will reduce the life of the boom and stick.

320 GC Hydraulic Excavator Specifications

Bucket Specifications and Compatibility (continued)

	Linkage	Width		Capacity		Weight		Fill %	Long Undercarriage		
		mm	in	m ³	yd ³	kg	lb		4.2 mt (9,300 lb) Counterweight		
									Reach Boom		
									R2.5 (8'2")	R2.9 (9'6")	
Pin-On, TRS18 S70											
Heavy Duty Grading	B	1600	63	1.00	1.31	691	1,523	100	●	⊙	
	B	1800	71	1.10	1.44	758	1,671	100	⊙	⊖	
Heavy Duty Digging	B	1150	45	0.90	1.18	778	1,715	100	●	⊙	
	B	1250	49	1.10	1.44	850	1,874	100	⊙	⊖	
Heavy Duty Trenching	B	600	24	0.55	0.72	460	1,014	100	●	●	
Maximum load with pin-on (payload + bucket)									kg	2759	2500
									lb	6,083	5,512
With S70, TRS18 S70											
Heavy Duty Grading	B	1600	63	1.00	1.31	691	1,523	100	⊙	⊖	
	B	1800	71	1.10	1.44	758	1,671	100	⊖	○	
Heavy Duty Digging	B	1150	45	0.90	1.18	778	1,715	100	⊙	⊖	
	B	1250	49	1.10	1.44	850	1,874	100	⊖	○	
Heavy Duty Trenching	B	600	24	0.55	0.72	460	1,014	100	●	●	
Maximum load with pin-on (payload + bucket)									kg	2504	2245
									lb	5,520	4,949
Pin-On, TRS18 HCS70/55											
Heavy Duty Grading	B	1600	63	1.00	1.31	694	1,530	100	⊙	⊖	
	B	1800	71	1.10	1.44	761	1,678	100	⊙	⊖	
Heavy Duty Digging	B	1150	45	0.90	1.18	774	1,706	100	●	⊙	
	B	1250	49	1.10	1.44	846	1,865	100	⊖	○	
Heavy Duty Trenching	B	600	24	0.55	0.72	482	1,063	100	●	●	
Maximum load with pin-on (payload + bucket)									kg	2663	2404
									lb	5871	5,300
HCS70/55, TRS18 HCS70/55											
Heavy Duty Grading	B	1600	63	1.00	1.31	694	1,530	100	⊖	○	
	B	1800	71	1.10	1.44	761	1,678	100	○	◇	
Heavy Duty Digging	B	1150	45	0.90	1.18	774	1,706	100	⊖	○	
	B	1250	49	1.10	1.44	846	1,865	100	○	◇	
Heavy Duty Trenching	B	600	24	0.55	0.72	482	1,063	100	●	●	
Maximum load with pin-on (payload + bucket)									kg	2256	1997
									lb	4,974	4,403

The above loads are in compliance with hydraulic excavator standard EN474-5:2006+A3:2013, they do not exceed 87% of hydraulic lifting capacity or 75% of tipping capacity with front linkage fully extended at ground line with bucket curled.

Capacity based on ISO 7451:2007.

Bucket weight with General Duty tips.

Maximum Material Density:

- 2100 kg/m³ (3,500 lb/yd³)
- ⊙ 1800 kg/m³ (3,000 lb/yd³)
- ⊖ 1500 kg/m³ (2,500 lb/yd³)
- 1200 kg/m³ (2,000 lb/yd³)
- ◇ 900 kg/m³ (1,500 lb/yd³)

Caterpillar recommends using appropriate work tools to maximize the value customers receive from our products. Use of work tools, including buckets, which are outside of Caterpillar's recommendations or specifications for weight, dimensions, flows, pressures, etc. may result in less-than-optimal performance, including but not limited to reductions in production, stability, reliability, and component durability. Improper use of a work tool resulting in sweeping, prying, twisting and/or catching of heavy loads will reduce the life of the boom and stick.

320 GC Hydraulic Excavator Specifications

Attachments Offering Guide

Not all Attachments are available in all regions. Consult your Cat dealer for configurations available in your region.

Match
 † Allowed usage on machine less than 50%
 No Match

PIN-ON ATTACHMENTS

Undercarriage		Long	
Counterweight		4.2 mt (9,300 lb)	
Boom Type		Reach	
Stick Length		R2.5 (8'2")	R2.9 (9'6")
Hydraulic Hammers	H115 S	✓	✓
	H120 GC S	✓	✓
	H120 S	✓	✓
	H130 GC S	✓†	
	H130 S	✓	✓†
Multi-Processors	MP318 Concrete Cutter Jaw	✓	✓
	MP318 Demolition Jaw	✓	✓
	MP318 Pulverizer Jaw	✓	✓
	MP318 Shear Jaw	✓	✓
	MP318 Universal Jaw	✓	✓
Demolition and Sorting Grapples	G317 GC	✓	✓
	G318	✓	✓
	G318 WH-800	✓	✓
	G318 WH-1100	✓	✓
Mobile Scrap and Demolition Shears	S3025 Flat Top	✓	✓
Pulverizers	P218 Secondary Pulverizer	✓	✓
	P318 Primary Pulverizer	✓	✓
Compactors (Vibratory Plate)	CVP110	✓	✓
Rotary Cutters	RC20	✓	✓

(continued on next page)

320 GC Hydraulic Excavator Specifications

Attachments Offering Guide *(continued)*

Not all Attachments are available in all regions. Consult your Cat dealer for configurations available in your region.

1800 kg/m³ (3,000 lb/yd³)
 1200 kg/m³ (2,000 lb/yd³)
 600 kg/m³ (1,000 lb/yd³)
 No Match

PIN-ON ATTACHMENTS *(continued)*

Undercarriage		Long	
Counterweight		4.2 mt (9,300 lb)	
Boom Type		Reach	
Stick Length		2.50 m (8'2")	2.92 m (9'7")
Orange Peel Grapples	GSH420-500	●	●
	GSH420-600	●	●
	GSH420-750	●	●
	GSH425-750	●	○
	GSH425-950	○	○
	GSH425-1150	○	
	GSH520-500	●	●
	GSH520-600	●	●
	GSH520-750	●	●
	GSH525-750	○	○
	GSH525-950	○	
	GSV420-400	●	●
	GSV420-500	●	●
	GSV420-600	●	●
	GSV420-750	●	●
	GSV420-1250	◇	◇
	GSV425-600	●	●
	GSV425-750	●	○
	GSV425-950	○	○
	GSV425-1150	○	
	GSV425-1550	◇	◇
	GSV520 GC-400	●	●
	GSV520 GC-500	●	●
	GSV520 GC-600	●	●
	GSV520 GC-750	●	●
	GSV520-400	●	●
	GSV520-500	●	●
	GSV520-600	●	●
	GSV520-750	●	●
	GSV525-600	●	●
	GSV525-750	○	○
	GSV525-950	○	
	Clamshell Grapples	CTV15-1000	●
CTV15-1200		○	○

(continued on next page)

320 GC Hydraulic Excavator Specifications

Attachments Offering Guide *(continued)*

Not all Attachments are available in all regions. Consult your Cat dealer for configurations available in your region.

Match
 * Working range front only
 † Allowed usage on machine less than 50%
 No Match

CAT PIN GRABBER COUPLER ATTACHMENTS

Undercarriage		Long	
Counterweight		4.2 mt (9,300 lb)	
Boom Type		Reach	
Stick Length		R2.5 (8'2")	R2.9 (9'6")
Hydraulic Hammers	H115 S	✓	✓
	H120 GC S	✓†	✓†
	H120 S	✓†	✓†
	H130 GC S	✓†	✓†
	H130 S	✓†	✓†
Multi-Processors	MP318 Concrete Cutter Jaw	✓	✓
	MP318 Demolition Jaw	✓	✓
	MP318 Pulverizer Jaw	✓	✓
	MP318 Shear Jaw	✓	✓
	MP318 Universal Jaw	✓	✓
Demolition and Sorting Grapples	G317 GC	✓	✓
	G318	✓	✓
	G318 WH-800	✓	✓
	G318 WH-1100	✓	✓*
Mobile Scrap and Demolition Shears	S3025 Flat Top	✓	
Pulverizers	P218 Secondary Pulverizer	✓	✓
	P318 Primary Pulverizer	✓	✓
Compactors (Vibratory Plate)	CVP110	✓	✓
Rotary Cutters	RC20	✓	✓

(continued on next page)

320 GC Hydraulic Excavator Specifications

Attachments Offering Guide *(continued)*

Not all Attachments are available in all regions. Consult your Cat dealer for configurations available in your region.

Match
 † Allowed usage on machine less than 50%

CW-40s DEDICATED COUPLER ATTACHMENTS

Undercarriage		Long	
Counterweight		4.2 mt (9,300 lb)	
Boom Type		Reach	
Stick Length		R2.5 (8'2")	R2.9 (9'6")
Hydraulic Hammers	H115 S	✓	✓
	H120 GC S	✓†	✓†
	H120 S	✓†	✓†
	H130 S	✓†	✓†
Multi-Processors	MP318 Concrete Cutter Jaw	✓	✓
	MP318 Demolition Jaw	✓	✓
	MP318 Pulverizer Jaw	✓	✓
	MP318 Shear Jaw	✓	✓
	MP318 Universal Jaw	✓	✓
Demolition and Sorting Grapples	G317 GC	✓	✓
	G318	✓	✓
	G318 WH-800	✓	✓
	G318 WH-1100	✓	✓
Mobile Scrap and Demolition Shears	S3025 Flat Top	✓	✓
Pulverizers	P218 Secondary Pulverizer	✓	✓
	P318 Primary Pulverizer	✓	✓
Compactors (Vibratory Plate)	CVP110	✓	✓
Rotary Cutters	RC20	✓	✓

(continued on next page)

320 GC Hydraulic Excavator Specifications

Attachments Offering Guide *(continued)*

Not all Attachments are available in all regions. Consult your Cat dealer for configurations available in your region.

Match † Allowed usage on machine less than 50%

CW-40 DEDICATED COUPLER ATTACHMENTS

Undercarriage		Long	
Counterweight		4.2 mt (9,300 lb)	
Boom Type		Reach	
Stick Length		R2.5 (8'2")	R2.9 (9'6")
Hydraulic Hammers	H115 S	✓	✓
	H120 GC S	✓†	✓†
	H120 S	✓†	✓†
	H130 GC S	✓†	✓†
	H130 S	✓†	✓†
Multi-Processors	MP318 Concrete Cutter Jaw	✓	✓
	MP318 Demolition Jaw	✓	✓
	MP318 Pulverizer Jaw	✓	✓
	MP318 Shear Jaw	✓	✓
	MP318 Universal Jaw	✓	✓
Demolition and Sorting Grapples	G317 GC	✓	✓
	G317 GC fixed CAN	✓	✓
	G318	✓	✓
	G318 fixed CAN	✓	✓
	G318 WH-800	✓	✓
	G318 WH-1100	✓	✓
Mobile Scrap and Demolition Shears	S3025 Flat Top	✓	✓
Pulverizers	P218 Secondary Pulverizer	✓	✓
	P318 Primary Pulverizer	✓	✓
Compactors (Vibratory Plate)	CVP110	✓	✓
Rotary Cutters	RC20	✓	✓

(continued on next page)

320 GC Hydraulic Excavator Specifications

Attachments Offering Guide *(continued)*

Not all Attachments are available in all regions. Consult your Cat dealer for configurations available in your region.

Match † Allowed usage on machine less than 50%

S70 DEDICATED COUPLER ATTACHMENTS

Undercarriage		Long	
Counterweight		4.2 mt (9,300 lb)	
Boom Type		Reach	
Stick Length		R2.5 (8'2")	R2.9 (9'6")
Hydraulic Hammers	H115 S	✓	✓
	H120 GC S	✓†	✓†
	H120 S	✓†	✓†
	H130 S	✓†	✓†
Multi-Processors	MP318 Concrete Cutter Jaw	✓	✓
	MP318 Demolition Jaw	✓	✓
	MP318 Pulverizer Jaw	✓	✓
	MP318 Shear Jaw	✓	✓
	MP318 Universal Jaw	✓	✓
Demolition and Sorting Grapples	G317 GC	✓	✓
	G318	✓	✓
	G318 WH-800	✓	✓
	G318 WH-1100	✓	✓
Mobile Scrap and Demolition Shears	S3025 Flat Top	✓	✓
Pulverizers	P218 Secondary Pulverizer	✓	✓
	P318 Primary Pulverizer	✓	✓
Compactors (Vibratory Plate)	CVP110	✓	✓
Rotary Cutters	RC20	✓	✓

(continued on next page)

320 GC Hydraulic Excavator Specifications

Attachments Offering Guide *(continued)*

Not all Attachments are available in all regions. Consult your Cat dealer for configurations available in your region.

Match
 * Working range front only
 † Allowed usage on machine less than 50%
 No Match

HCS70 COUPLER ATTACHMENTS

Undercarriage		Long	
Counterweight		4.2 mt (9,300 lb)	
Boom Type		Reach	
Stick Length		R2.5 (8'2")	R2.9 (9'6")
Hydraulic Hammers	H115 S	✓	✓
	H120 S	✓†	✓†
	H130 S	✓†	✓†
Multi-Processors	MP318 Concrete Cutter Jaw	✓	✓
	MP318 Demolition Jaw	✓	✓
	MP318 Pulverizer Jaw	✓	✓
	MP318 Shear Jaw	✓	✓
	MP318 Universal Jaw	✓	✓
Demolition and Sorting Grapples	G317 GC	✓	✓
	G318	✓	✓
	G318 WH-800	✓	✓
	G318 WH-1100	✓	✓*
Mobile Scrap and Demolition Shears	S3025 Flat Top	✓	
Pulverizers	P218 Secondary Pulverizer	✓	✓
	P318 Primary Pulverizer	✓	✓
Compactors (Vibratory Plate)	CVP110	✓	✓
Rotary Cutters	RC20	✓	✓

(continued on next page)

320 GC Hydraulic Excavator Specifications

Attachments Offering Guide *(continued)*

Not all Attachments are available in all regions. Consult your Cat dealer for configurations available in your region.

Match
 * Working range front only
 † Allowed usage on machine less than 50%
 No Match

HCS70/55 COUPLER ATTACHMENTS

Undercarriage		Long	
Counterweight		4.2 mt (9,300 lb)	
Boom Type		Reach	
Stick Length		R2.5 (8'2")	R2.9 (9'6")
Hydraulic Hammers	H115 S	✓	✓
	H120 S	✓†	✓†
	H130 S	✓†	✓†
Multi-Processors	MP318 Concrete Cutter Jaw	✓	✓
	MP318 Demolition Jaw	✓	✓
	MP318 Pulverizer Jaw	✓	✓*
	MP318 Shear Jaw	✓	✓
	MP318 Universal Jaw	✓	✓
Demolition and Sorting Grapples	G317 GC	✓	✓
	G318	✓	✓
	G318 WH-800	✓	✓
	G318 WH-1100	✓	✓*
Mobile Scrap and Demolition Shears	S3025 Flat Top	✓*	
Pulverizers	P218 Secondary Pulverizer	✓	✓
	P318 Primary Pulverizer	✓	✓*
Compactors (Vibratory Plate)	CVP110	✓	✓
Rotary Cutters	RC20	✓	✓

BOOM-MOUNT ATTACHMENTS

Undercarriage		Long	
Counterweight		4.2 mt (9,300 lb)	
Boom Type		Reach	
Mobile Scrap and Demolition Shears	S2050	✓	
	S3035 Flat Top	✓	

320 GC Standard and Optional Equipment

Standard and Optional Equipment

Standard and optional equipment may vary. Consult your Cat dealer for details.

	Standard	Optional		Standard	Optional
CAB			ENGINE		
ROPS	✓		Cat® C4.4 single turbo engine	✓	
High-resolution 203 mm (8") LCD touchscreen monitor	✓		Two selectable power modes	✓	
Auto bi-level air conditioner	✓		Auto engine speed control	✓	
Jog dial and shortcut keys for monitor control	✓		Auto engine idle shutdown	✓	
Keyless push-to-start engine control	✓		Work up to 3000 m (9,842.5 ft) above sea level without engine power de-rating	✓	
Height-adjustable console, three steps with tool	✓		52° C (125° F) high-ambient cooling capacity	✓	
Fixed left-side console	✓		Cold starting capability for -32° C (-25° F)	✓	
Air-suspension seat	✓		Double element air filter with integrated pre-cleaner	✓	
51 mm (2") seat belt	✓		Electric fuel priming pump	✓	
Digital Audio Broadcasting (DAB)/ DAB+ radio with Bluetooth® (includes USB/Aux ports)	✓		Electric cooling fans with auto-reverse function	✓	
12V DC outlets	✓		HYDRAULIC SYSTEM		
Document storage	✓		Boom and stick regeneration circuits	✓	
Cup and bottle holders	✓		Boom/stick lowering check valves	✓	
Openable two-piece front window	✓		SmartBoom™		✓
Rear window emergency exit	✓		Electronic main control valve	✓	
Radial wiper with washer	✓		Auto warm up	✓	
Openable steel hatch	✓		Auto two-speed travel	✓	
LED dome light	✓		Boom and stick drift reduction valve	✓	
Roller front sunscreen	✓		Element type main hydraulic filter	✓	
Roller rear sunscreen		✓	Slider joysticks	✓	
Washable floor mat	✓		Tandem type electronic main pump	✓	
Beacon ready	✓		Advanced Tool Control (two pumps, one/two way high-pressure flow)	✓	
			Medium pressure circuit		✓
			Quick coupler circuit for Cat pin grabber	✓	

(continued on next page)

320 GC Standard and Optional Equipment

Standard and Optional Equipment *(continued)*

Standard and optional equipment may vary. Consult your Cat dealer for details.

	Standard	Optional		Standard	Optional
UNDERCARRIAGE AND STRUCTURES			CAT TECHNOLOGY		
600 mm (24 in) triple grouser track shoes		✓	VisionLink®	✓	
700 mm (28 in) triple grouser track shoes		✓	VisionLink Productivity		✓
790 mm (31 in) triple grouser track shoes		✓	Remote Flash	✓	
900 mm (35 in) triple grouser track shoes		✓	SERVICE AND MAINTENANCE		
Segmented track guiding guards	✓		Scheduled Oil Sampling (S·O·S SM) ports	✓	
Bottom guard	✓		Grouped location for engine oil and fuel filters	✓	
Swivel guard		✓	Ground-level second dipstick for engine oil	✓	
Travel motor guards	✓		Side entry to service platform	✓	
Grease lubricated track links	✓		Electric refueling pump with automatic shutoff	✓	
4.2 mt (9,300 lb) counterweight	✓		Integrated vehicle health management system	✓	
Swing frame	✓		SAFETY AND SECURITY		
Base frame with HD track rollers and standard carrier rollers	✓		Auto hammer stop	✓	
Final drive with bio oil capable travel motor	✓		Rear and right-hand-sideview cameras	✓	
BOOM, STICKS AND LINKAGES			Cab mirror for Right Hand (RH) side track edge	✓	
5.7 m (18'8") Reach boom	✓		Cat PL161 attachment locator		✓
2.9 m (9'6") Reach stick		✓	Neutral lever (lock out) for all controls	✓	
2.5 m (8'2") Reach stick		✓	Anti-skid plate and countersunk bolts on service platform	✓	
Bucket linkage, B1-family with lifting eye		✓	Lockable disconnect switch	✓	
Bucket linkage, B1-family without lifting eye		✓	Swing alarm		✓
ELECTRICAL SYSTEM			Ground-level accessible secondary engine shutoff switch	✓	
1,000 CCA maintenance-free batteries (×2)	✓		RH handrail and handhold	✓	
Centralized electrical disconnect switch	✓		OPG guards		✓
Programmable time-delay LED working lights	✓		Inspection lighting		✓
LED chassis light, boom lights, cab lights	✓				

*Connect subscription only. Additional subscriptions are available. Contact your Cat dealer for availability.

Dealer Installed Kit and Attachments

Attachments may vary. Consult your Cat dealer for details.

CAB

- Lower radial wiper
- Rain protector plus cab light cover
- Polycarbonate roof hatch
- Sun visor, slider
- Laminated P5A glass front windshield
- Left Hand (LH)/RH electrical pedal for tool control
- Armrest kit
- Dual exit rear window kit
- 75 mm (3") retractable seat belt
- Lunch box net
- Rear storage
- Tool box

GUARDS

- Swivel guard
- Side rubber bumper guard
- Operator Protective Guards
- Mesh guard full front
- Mesh guard half front
- Full protecting vandalism guard

MAINTENANCE

- Duct ready kit

SAFETY AND SECURITY

- Bluetooth receiver

320 GC Environmental Declaration

The following information applies to the machine at the time of final manufacture as configured for sale in the regions covered in this document. The content of this declaration is valid as of the date issued; however, content related to machine features and specifications are subject to change without notice. For additional information, please see the machine's Operation and Maintenance Manual.

For more information on sustainability in action and our progress, please visit <https://www.caterpillar.com/en/company/sustainability>.

Engine

- The Cat® C4.4 engine meets U.S. EPA Tier 4 Final, EU Stage V, and Japan 2014 emission standards.
- Cat diesel engines are required to use ULSD (ultra-low sulfur diesel fuel with 15 ppm of sulfur or less) or ULSD blended with the following lower-carbon intensity fuels** up to:
 - ✓ 20% biodiesel FAME (fatty acid methyl ester)*
 - ✓ 100% renewable diesel, HVO (hydrogenated vegetable oil) and GTL (gas-to-liquid) fuels

Refer to guidelines for successful application. Please consult your Cat dealer or “Caterpillar Machine Fluids Recommendations” (SEBU6250) for details.

**Engines with no aftertreatment devices can use higher blends, up to 100% biodiesel (for use of blends higher than 20% biodiesel, consult your Cat dealer).*

***Tailpipe greenhouse gas emissions from lower-carbon intensity fuels are essentially the same as traditional fuels.*

Air Conditioning System

- The air conditioning system on this machine contains the fluorinated greenhouse gas refrigerant R134a (Global Warming Potential = 1430). The system contains 0.85 kg (1.9 lb) of refrigerant which has a CO₂ equivalent of 1.216 metric tonnes (1.340 tons).

Paint

- Based on best available knowledge, the maximum allowable concentration, measured in parts per million (PPM), of the following heavy metals in paint are:
 - Barium < 0.01%
 - Cadmium < 0.01%
 - Chromium < 0.01%
 - Lead < 0.01%

Sound Performance

ISO 6395:2008 (external) – 101 dB(A)

ISO 6396:2008 (inside cab) – 70 dB(A)

- Hearing protection may be needed when operating with an open operator station and cab (when not properly maintained or doors/windows open) for extended periods or in a noisy environment.

Oils and Fluids

- Caterpillar factory fills with ethylene glycol coolants. Cat Diesel Engine Antifreeze/Coolant (DEAC) and Cat Extended Life Coolant (ELC) can be recycled. Consult your Cat dealer for more information.
- Cat Bio HYDO™ Advanced is an EU Ecolabel approved biodegradable hydraulic oil.
- Additional fluids are likely to be present, please consult the Operations and Maintenance Manual or the Application and Installation guide for complete fluid recommendations and maintenance intervals.

Features and Technology

- The following features and technology may contribute to fuel savings and/or carbon reduction. Features may vary. Consult your Cat dealer for details.
 - Advanced hydraulic systems balance power and efficiency
 - Smart mode matches machine power to digging requirements automatically
 - Eco mode minimizes fuel consumption for light applications
 - Cut maintenance costs up to 25% with extended service intervals
 - Programmable high-efficiency cooling fans run only when needed
 - The latest hydraulic oil filter provides longer life with a 3,000-hour replacement interval

Recycling

- The materials included in machines are categorized as below with approximate weight percentage. Because of variations of product configurations, the following values in the table may vary.

Material Type	Weight Percentage
Steel	82.67%
Iron	5.61%
Nonferrous Metal	2.68%
Mixed Metal	1.28%
Mixed-Metal and Nonmetal	1.07%
Plastic	1.35%
Rubber	0.08%
Mixed Nonmetallic	0.23%
Fluid	3.33%
Other	1.70%
Uncategorized	0.00%
Total	100%

- A machine with higher recyclability rate will ensure more efficient usage of valuable natural resources and enhance End-of-Life value of the product. According to ISO 16714:2008 (Earthmoving machinery – Recyclability and recoverability – Terminology and calculation method), recyclability rate is defined as percentage by mass (mass fraction in percent) of the new machine potentially able to be recycled, reused or both.

All parts in the bill of material are first evaluated by component type based on a list of components defined by the ISO 16714:2008 and Japan CEMA (Construction Equipment Manufacturers Association) standards. Remaining parts are further evaluated for recyclability based on material type.

Because of variations of product configurations, the following value in the table may vary.

Recyclability – 97%



320 GC Narrow

Hydraulic Excavator

The Cat 320 GC Narrow excavator is designed with transportation in mind. Its undercarriage is sized just right to make it fit nicely on trailers and space-restricted jobsites.

High Performance

- The excavator's 2.54 m (8'3") width makes it easier to get into space-restricted areas compared to a standard width model.
- Additional counterweight enables the excavator to lift like a standard width model.
- The C4.4 engine is fuel efficient and meets EU Stage V emission standards.
- High-ambient cooling and cold start capability enable year-round work.
- Smart mode automatically matches engine and hydraulic power to digging conditions for maximum efficiency.
- Do different jobs quickly and efficiently with purpose-built Cat attachments.

Simple to Operate

- Start the engine with a push button or use a Bluetooth key fob, smartphone app, or Operator ID passcode.
- Program power mode and joystick response and pattern using Operator ID; the machine will remember the settings each time you go to work.
- Navigate quickly on the standard high-resolution 203 mm (8 in) touchscreen monitor or with the aid of the jog dial control.
- Not sure how a function works? The operator's manual is at your fingertips in the touchscreen monitor.

Work in Comfort

- The wide seat is adjustable for operators of all sizes.
- Easy-to-reach controls all located in front of you reduce twisting and turning.
- Standard automatic climate control keeps you at the right temperature all shift long.
- Advanced viscous mounts reduce cab vibration up to 50 percent over previous excavator series.
- Convenience features include a radio, auxiliary port for headphones, and a USB port for connecting and charging devices.
- Stow your gear with plenty of storage, including a cup holder, cell phone slot, and space behind the seat for a large lunchbox.

Easy to Maintain

- Do all routine maintenance at ground level.
- The hydraulic oil system requires no maintenance for 3,000 hours – 50 percent longer than the previous series.
- Change fuel filters at 1,000 hours – double the interval from the previous filters.
- The air intake filter with pre-cleaner has double the dust holding capacity of the previous air intake filter.

Built-In Safety

- No need to climb on top of the machine with daily maintenance points at ground level.
- The right-hand service platform design enables trouble-free access to upper service platform.
- Serrated steps and anti-skid punch plate prevent slipping.
- Keep your excavator secure with Operator ID; use your PIN code to enable pushbutton starting.
- Enjoy great visibility into the trench, in each swing direction, and behind you with the help of smaller cab posts and larger windows.



320 GC Narrow Hydraulic Excavator Specifications

Engine

Engine model	Cat C4.4	
Net Power		
ISO 9249	109 kW	146 hp
ISO 9249 (DIN)	148 hp (metric)	
Engine Power		
ISO 14396	110 kW	148 hp
ISO 14396 (DIN)	150 hp (metric)	
Bore	105 mm	4 in
Stroke	127 mm	5 in
Displacement	4.40 L	269 in ³
Biodiesel Capability	Up to B20 ⁽¹⁾	

- Meets U.S. EPA Tier 4 Final, EU Stage V, and Japan 2014 emission standards.
- No engine power derating required below 3000 m (9,842.5 ft) altitude. (4500 m [14,764 ft] altitude with engine power derate.)
- Advertised power is tested per the specified standard in effect at the time of manufacture.
- Net power advertised is the power available at the flywheel when the engine is equipped with fan, air intake system, exhaust system and alternator.
- Engine speed at 2,000 rpm.

⁽¹⁾Cat diesel engines are required to use ULSD (ultra-low sulfur diesel fuel with 15 ppm of sulfur or less) or ULSD blended with the following lower-carbon intensity fuels** up to:

- ✓ 20% biodiesel FAME (fatty acid methyl ester)*
- ✓ 100% renewable diesel, HVO (hydrogenated vegetable oil) and GTL (gas-to-liquid) fuels

Refer to guidelines for successful application. Please consult your Cat dealer or “Caterpillar Machine Fluids Recommendations” (SEBU6250) for details.

**Engines with no aftertreatment devices can use higher blends, up to 100% biodiesel (for use of blends higher than 20% biodiesel, consult your Cat dealer).*

***Tailpipe greenhouse gas emissions from lower-carbon intensity fuels are essentially the same as traditional fuels.*

Swing Mechanism

Swing Speed	11.12 rpm	
Swing Torque	62 kN·m	45,611 lb-ft
Maximum Swing Torque	74 kN·m	54,435 lb-ft

Weights

Operating Weight	22 600 kg	49,800 lb
------------------	-----------	-----------

- Long Narrow undercarriage, Reach boom, R2.5 (8'2") Stick, GD 1.3 m³ (1.87 yd³) bucket, 500 mm (20 in) triple grouser shoes and 4.55 mt (10,000 lb) counterweight.

Track

Standard Track Shoes Width	500 mm	20 in
Number of Shoes (each side)	49	
Number of Track Rollers (each side)	8	
Number of Carrier Roller (each side)	2	

Drive

Gradeability	35°/70%	
Maximum Travel Speed	5.9 km/h	3.6 mph
Maximum Drawbar Pull – Long Undercarriage	205 kN	46,063 lbf

Standards

Brakes	ISO 10265:2008	
Cab/OPG (optional)	ISO 10262:1998 Level II	
Cab/ROPS	ISO 12117-2:2008	

Hydraulic System

Main System – Maximum Flow – Implement	442 L/min (221 × 2 pumps)	117 gal/min (58.5 × 2 pumps)
Swing System – Maximum Flow	No swing pump	
Maximum Pressure – Equipment – Normal	35 000 kPa	5,075 psi
Maximum Pressure – Travel	35 000 kPa	5,075 psi
Maximum Pressure – Swing	25 000 kPa	3,625 psi
Boom Cylinder – Bore	120 mm	5 in
Boom Cylinder – Stroke	1260 mm	50 in
Stick Cylinder – Bore	140 mm	6 in
Stick Cylinder – Stroke	1504 mm	59 in
Bucket Cylinder – Bore	120 mm	5 in
Bucket Cylinder – Stroke	1104 mm	43 in

320 GC Narrow Hydraulic Excavator Specifications

Service Refill Capacities

Fuel Tank	267 L	70.5 gal
Cooling System	12.5 L	3.3 gal
Engine Oil	15 L	4.0 gal
Swing Drive	5.5 L	1.5 gal
Final Drive (each)	4.5 L	1.2 gal
Hydraulic System (including tank)	218 L	57.6 gal
Hydraulic Tank	115 L	30.4 gal
DEF Tank	26 L	6.9 gal

Sound Performance

ISO 6395:2008 (external)	103 dB(A) EU Certified Data
ISO 6396:2008 (inside cab)	70 dB(A)

- Hearing protection may be needed when operating with an open operator station and cab (when not properly maintained or doors/windows open) for extended periods or in a noisy environment.

Air Conditioning System

The air conditioning system on this machine contains the fluorinated greenhouse gas refrigerant R134a (Global Warming Potential = 1430). The system contains 0.9 kg (1.98 lb) of refrigerant which has a CO₂ equivalent of 1.287 metric tonnes (1.419 tons).

320 GC Narrow Hydraulic Excavator Specifications

Operating Weights and Ground Pressures

Base Machine Configurations	500 mm (20 in) Triple Grouser Shoes	
	Weight kg (lb)	Ground Pressure kPa (psi)
Base Frame with Track Rollers and Carrier Rollers		
4.55 mt (10,000 lb) Counterweight + Long Narrow Undercarriage Base Machine		
Reach Boom + R2.5 (8'2") Stick + 1.30 m ³ (1.87 yd ³) Bucket + QC without pins	22 600 (49,800)	56.4 (8.2)

All operating weights include a 90% fuel tank with 75 kg (165 lb) operator.

The formula in the Machine Weight and Ground Pressure cells could be used for the specific configuration calculation by flipping the below major component weight.

Major Component Weights

	kg	lb
Base Machine Weight (with 4.55 mt [10,000 lb] counterweight, upper frame, long narrow undercarriage with track rollers and two boom cylinders – does not include boom, stick, bucket, stick cylinder, bucket cylinder, tracks, 90% fuel tank and 75 kg [165 lb] operator).	15 870	35,000
Track Shoes:		
500 mm (20") Width, 8.5 mm (0.33") Thick Triple Grouser Shoes	2440	5,400
Two Boom Cylinders	360	800
Weight of 90% Fuel Tank and 75 kg (165 lb) Operator	280	600
Counterweight:		
4.55 mt (10,000 lb) Counterweight	4550	10,000
Boom (including lines, pins, stick cylinder):		
Reach Boom 5.7 m (18'8")	1830	4,000
Sticks (including lines, pins, bucket cylinder, bucket linkage):		
Reach stick R2.5B1 (8'2")	1050	2,300
Reach stick R2.9B1 (9'6")	1100	2,400
Buckets (without linkage, with tips and side cutters):		
1.30 GD	880	1,900
1.30 GD for CW QC	850	1,900
Quick Couplers:		
Pin Grabber QC B Without Pins	430	900
CW QC B Without Pins	250	600

320 GC Narrow Hydraulic Excavator Specifications

Dimensions

All dimensions are approximate and may vary depending on bucket selection.

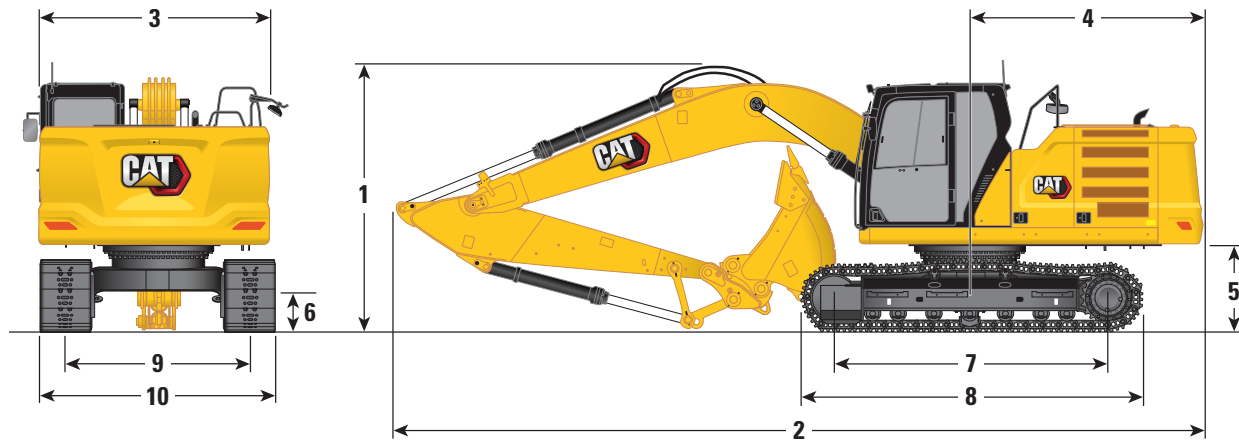

Boom Option

Reach Boom
5.7 m (18'8")

Stick Options

Reach Stick
R2.5B1 (8'2")

Reach Stick
R2.9B1 (9'6")

Undercarriage Type

Long Narrow

		Reach Stick R2.5B1 (8'2")	Reach Stick R2.9B1 (9'6")
1 Machine Height:			
Top of Cab Height	2980 mm	9'9"	2980 mm 9'9"
Top of OPG Height	3120 mm	10'3"	3120 mm 10'3"
Handrail Height	2970 mm	9'9"	2970 mm 9'9"
With Boom/Stick/Bucket Installed	3100 mm	10'2"	3060 mm 10'1"
With Boom/Stick Installed	2850 mm	9'4"	2940 mm 9'8"
With Boom Installed	2400 mm	7'10"	2400 mm 7'10"
2 Machine Length:			
With Boom/Stick/Bucket Installed	9570 mm	31'5"	9550 mm 31'4"
With Boom/Stick Installed	9520 mm	31'3"	9530 mm 31'3"
With Boom Installed	8490 mm	27'10"	8490 mm 27'10"
3 Upperframe Width	2540 mm	8'4"	2540 mm 8'4"
4 Tail Swing Radius	2820 mm	9'3"	2820 mm 9'3"
5 Counterweight Clearance*	1040 mm	3'5"	1040 mm 3'5"
6 Ground Clearance	440 mm	1'5"	440 mm 1'5"
7 Length to Center of Rollers	3650 mm	12'0"	3650 mm 12'0"
8 Crawler Overall Length	4460 mm	14'7"	4460 mm 14'7"
9 Track Gauge – Extended	2000 mm	6'7"	2000 mm 6'7"
10 Undercarriage Width:			
500 mm (20 in) Shoes	2500 mm	8'2"	2500 mm 8'2"
Bucket Type		GD	GD
Bucket Capacity	1.30 m ³	1.87 yd ³	1.30 m ³ 1.87 yd ³
Bucket Tip Radius	1570 mm	5'2"	1570 mm 5'2"

*Without grouser height.

320 GC Narrow Hydraulic Excavator Specifications

Working Ranges

All dimensions are approximate and may vary depending on bucket selection.

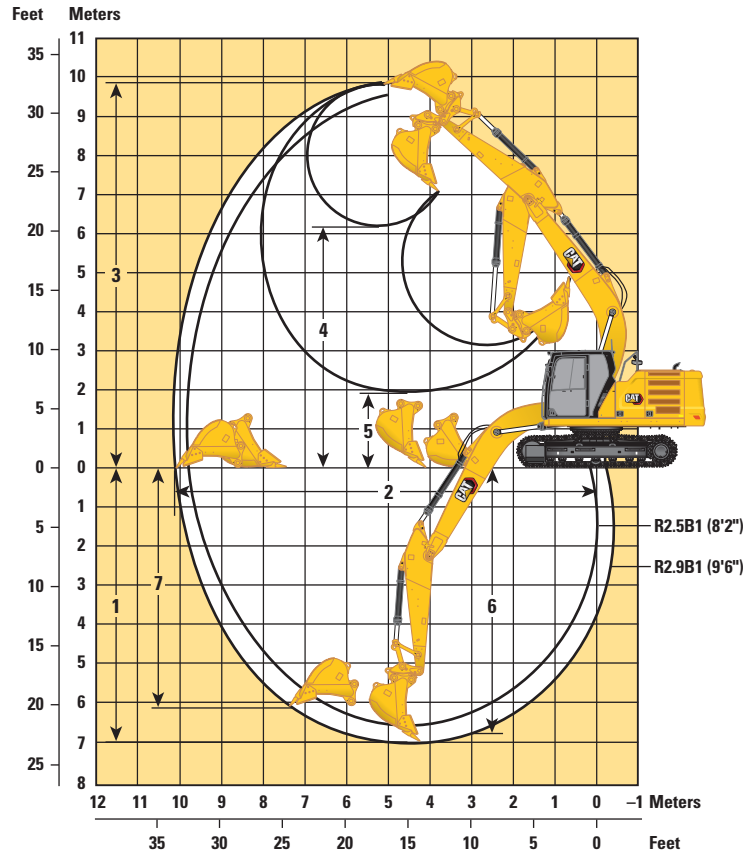

Boom Option

Reach Boom
5.7 m (18'8")

Stick Options

Reach Stick
R2.5B1 (8'2")

Reach Stick
R2.9B1 (9'6")

Undercarriage Type

Long Narrow

		Reach Stick R2.5B1 (8'2")	Reach Stick R2.9B1 (9'6")
1 Maximum Digging Depth	6580 mm	21'7"	7000 mm 23'0"
2 Maximum Reach at Ground Line	9740 mm	31'11"	10 140 mm 33'3"
3 Maximum Cutting Height	9600 mm	31'6"	9810 mm 32'2"
4 Maximum Loading Height	6010 mm	19'9"	6220 mm 20'5"
5 Minimum Loading Height	2320 mm	7'7"	1900 mm 6'3"
6 Maximum Depth Cut for 2440 mm (8'0") Level Bottom	6400 mm	21'0"	6840 mm 22'5"
7 Maximum Vertical Wall Digging Depth	5780 mm	19'0"	6190 mm 20'4"
Bucket Digging Force (ISO)	141 kN	31,586 lbf	141 kN 31,586 lbf
Stick Digging Force (ISO)	118 kN	26,492 lbf	107 kN 23,987 lbf
Bucket Type		GD	GD
Bucket Capacity	1.30 m ³	1.87 yd ³	1.30 m ³ 1.87 yd ³
Bucket Tip Radius	1574 mm	5'2"	1574 mm 5'2"

320 GC Narrow Hydraulic Excavator Specifications

Reach Boom Lift Capacities – Counterweight: 4.55 mt (10,000 lb) – without Bucket

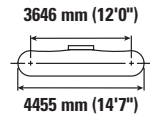
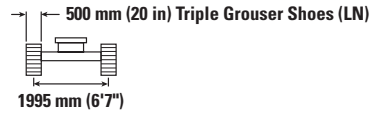
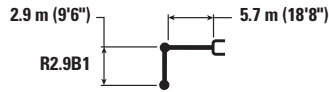

Reach Boom Configuration	1500 mm/5'0"		3000 mm/10'0"		4500 mm/15'0"		6000 mm/20'0"		7500 mm/25'0"		mm ft/in		
	kg lb	kg lb	kg lb	kg lb	kg lb	kg lb	kg lb	kg lb	kg lb	kg lb	mm ft/in	mm ft/in	
7500 mm 25'0"							*4950	*4950			*4250 *9,450	*4250 *9,450	6160 19'9"
6000 mm 20'0"							*5400 *11,800	4950 10,650			*3950 *8,700	3600 8,000	7290 23'8"
4500 mm 15'0"							*5900 *12,900	4800 10,300	*5550 *12,200	3400 7,300	*3850 *8,500	3050 6,750	7990 26'1"
3000 mm 10'0"					*8650 *18,650	6850 14,750	*6800 *14,750	4550 9,800	*5950 *12,750	3300 7,050	*3950 *8,650	2800 6,150	8360 27'4"
1500 mm 5'0"					*10 500 *22,600	6350 13,700	*7700 *16,700	4300 9,300	5800 12,500	3200 6,850	*4200 *9,200	2700 5,900	8450 27'8"
0 mm 0'0"			*6800 *15,600	*6800 *15,600	*11 500 *24,850	6100 13,100	7900 16,950	4150 8,950	5700 12,250	3100 6,650	*4650 *10,200	2700 5,950	8260 27'0"
-1500 mm -5'0"	*7250 *16,200	*7250 *16,200	*11 700 *26,600	11 050 23,650	*11 600 *25,100	6000 12,900	7800 16,800	4100 8,800	5650 12,200	3050 6,600	5400 11,900	2950 6,450	7780 25'5"
-3000 mm -10'0"	*12 450 *27,850	*12 450 *27,850	*15 350 *33,250	11 200 24,050	*10 850 *23,400	6050 13,050	7850 16,850	4100 8,850			6400 14,150	3450 7,600	6940 22'7"
-4500 mm -15'0"			*12 200 *26,150	11 550 24,800	*8800 *18,700	6250 13,500					*6650 *14,600	4700 10,600	5590 18'0"

Reach Boom Lift Capacities – Counterweight: 4.55 mt (10,000 lb) – without Bucket

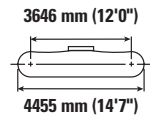
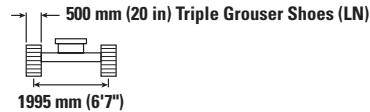
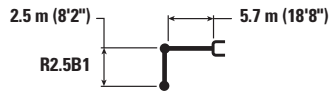

Reach Boom Configuration	3000 mm/10'0"		4500 mm/15'0"		6000 mm/20'0"		7500 mm/25'0"		mm ft/in		
	kg lb	kg lb	kg lb	kg lb	kg lb	kg lb	kg lb	kg lb	kg lb	mm ft/in	
7500 mm 25'0"									*5150 *11,400	*5150 *11,400	5610 17'11"
6000 mm 20'0"					*5850 *12,850	4900 10,500			*4700 *10,400	3950 8,800	6840 22'2"
4500 mm 15'0"			*7350 *15,900	7250 15,650	*6300 *13,750	4750 10,200	*5250 *12,700	3350 7,050	*4600 *10,150	3300 7,300	7570 24'8"
3000 mm 10'0"			*9250 *19,950	6750 14,550	*7150 *15,500	4550 9,750	5900 12,700	3300 7,050	*4750 *10,400	3000 6,600	7960 26'1"
1500 mm 5'0"			*10 950 *23,600	6300 13,600	*8000 *17,300	4300 9,300	5800 12,500	3200 6,850	*5050 *11,100	2900 6,300	8050 26'4"
0 mm 0'0"			*11 650 *25,250	6100 13,100	7900 17,000	4150 8,950	5750 12,300	3100 6,700	5350 11,800	2950 6,450	7860 25'9"
-1500 mm -5'0"	*12 350 *28,100	11 200 24,000	*11 500 *24,900	6050 13,050	7850 16,900	4100 8,850			5900 13,000	3200 7,050	7350 24'0"
-3000 mm -10'0"	*14 400 *31,250	11 350 24,400	*10 450 *22,600	6150 13,250	*7750 *16,550	4200 9,050			*6900 *15,250	3850 8,500	6460 21'0"
-4500 mm -15'0"			*7800 *16,300	6400 13,850					*6750 *14,800	5650 12,750	4970 15'11"



ISO 10567:2007



* Indicates that the load is limited by hydraulic lifting capacity rather than tipping load. The above loads are in compliance with hydraulic excavator lift capacity standard ISO 10567:2007. They do not exceed 87% of hydraulic lifting capacity or 75% of tipping load. Weight of all lifting accessories must be deducted from the above lifting capacities. Lifting capacities are based on the machine standing on a firm, uniform supporting surface. The use of a work tool attachment point to handle/lift objects, could affect the machine lift performance.

Lift capacity stays with ±5% for all available track shoes.

Always refer to the appropriate Operation and Maintenance Manual for specific product information.

320 GC Narrow Hydraulic Excavator Specifications

Bucket Specifications and Compatibility

	Linkage	Width		Capacity		Weight		Fill %	Long Narrow Undercarriage 4.55 mt (10,000 lb)	
		mm	in	m ³	yd ³	kg	lb		Reach Boom	
									R2.5 (8'2")	R2.9 (9'6")
Pin On (No Coupler)										
General Duty	B	600	24	0.46	0.61	555	1,223	100	●	●
	B	750	30	0.64	0.84	626	1,380	100	●	●
	B	1300	51	1.30	1.70	835	1,841	100	⊖	⊖
	B	1400	55	1.43	1.87	879	1,937	100	○	○
General Duty	B	600	24	0.46	0.60	550	1,212	100	●	●
	B	750	30	0.64	0.84	621	1,368	100	●	●
	B	1000	39	0.93	1.22	717	1,580	100	●	●
	B	1200	48	1.19	1.56	807	1,778	100	⊙	⊖
	B	1400	55	1.43	1.87	874	1,926	100	○	○
	B	1500	60	1.58	2.06	914	2,014	100	○	◇
Heavy Duty	B	1050	42	1.00	1.31	892	1,967	100	●	⊙
	B	1200	48	1.19	1.56	917	2,022	100	⊖	⊖
	B	1300	52	1.30	1.70	974	2,148	100	⊖	○
Severe Duty	B	1050	42	1.00	1.31	948	2,091	90	●	⊙
	B	1200	48	1.20	1.57	1011	2,229	90	⊙	⊖
Ditch Cleaning	B	2000	78	1.22	1.60	869	1,916	100	⊖	⊖
Ditch Cleaning Tilt	B	2000	79	1.23	1.61	1096	2,417	100	⊖	○
Maximum load with pin-on (payload + bucket)								kg	2900	2705
								lb	6,393	5,964

The above loads are in compliance with hydraulic excavator standard EN474-5:2006+A3:2013, they do not exceed 87% of hydraulic lifting capacity or 75% of tipping capacity with front linkage fully extended at ground line with bucket curled.

Capacity based on ISO 7451:2007.

Bucket weight with General Duty tips.

Maximum Material Density:

- 2100 kg/m³ (3,500 lb/yd³)
- ⊙ 1800 kg/m³ (3,000 lb/yd³)
- ⊖ 1500 kg/m³ (2,500 lb/yd³)
- 1200 kg/m³ (2,000 lb/yd³)
- ◇ 900 kg/m³ (1,500 lb/yd³)

Caterpillar recommends using appropriate work tools to maximize the value customers receive from our products. Use of work tools, including buckets, which are outside of Caterpillar's recommendations or specifications for weight, dimensions, flows, pressures, etc. may result in less-than-optimal performance, including but not limited to reductions in production, stability, reliability, and component durability. Improper use of a work tool resulting in sweeping, prying, twisting and/or catching of heavy loads will reduce the life of the boom and stick.

(continued on next page)

320 GC Narrow Hydraulic Excavator Specifications

Bucket Specifications and Compatibility *(continued)*

	Linkage	Width		Capacity		Weight		Fill %	Long Narrow Undercarriage 4.55 mt (10,000 lb)	
		mm	in	m ³	yd ³	kg	lb		Reach Boom	
									R2.5 (8'2")	R2.9 (9'6")
With Pin Grabber Coupler										
General Duty	B	600	24	0.46	0.61	555	1,223	100	●	●
	B	750	30	0.64	0.84	626	1,380	100	●	●
	B	1300	51	1.30	1.70	835	1,841	100	○	◇
	B	1400	55	1.43	1.87	879	1,937	100	◇	◇
General Duty	B	600	24	0.46	0.60	550	1,212	100	●	●
	B	750	30	0.64	0.84	621	1,368	100	●	●
	B	1000	39	0.93	1.22	717	1,580	100	⊙	⊖
	B	1200	48	1.19	1.56	807	1,778	100	○	○
	B	1400	55	1.43	1.87	874	1,926	100	◇	◇
Heavy Duty	B	1500	60	1.58	2.06	914	2,014	100	◇	◇
	B	1050	42	1.00	1.31	892	1,967	100	⊖	○
	B	1200	48	1.19	1.56	917	2,022	100	○	○
Severe Duty	B	1300	52	1.30	1.70	974	2,148	100	○	◇
	B	1050	42	1.00	1.31	948	2,091	90	⊖	⊖
	B	1200	48	1.20	1.57	1011	2,229	90	○	○
Ditch Cleaning	B	2000	78	1.22	1.60	869	1,916	100	○	○
Ditch Cleaning Tilt	B	2000	79	1.23	1.61	1096	2,417	100	◇	◇
								kg	2478	2283
								lb	5,464	5,034

The above loads are in compliance with hydraulic excavator standard EN474-5:2006+A3:2013, they do not exceed 87% of hydraulic lifting capacity or 75% of tipping capacity with front linkage fully extended at ground line with bucket curled.

Capacity based on ISO 7451:2007.

Bucket weight with General Duty tips.

Maximum Material Density:

- 2100 kg/m³ (3,500 lb/yd³)
- ⊙ 1800 kg/m³ (3,000 lb/yd³)
- ⊖ 1500 kg/m³ (2,500 lb/yd³)
- 1200 kg/m³ (2,000 lb/yd³)
- ◇ 900 kg/m³ (1,500 lb/yd³)

Caterpillar recommends using appropriate work tools to maximize the value customers receive from our products. Use of work tools, including buckets, which are outside of Caterpillar's recommendations or specifications for weight, dimensions, flows, pressures, etc. may result in less-than-optimal performance, including but not limited to reductions in production, stability, reliability, and component durability. Improper use of a work tool resulting in sweeping, prying, twisting and/or catching of heavy loads will reduce the life of the boom and stick.

(continued on next page)

320 GC Narrow Hydraulic Excavator Specifications

Bucket Specifications and Compatibility (continued)

	Linkage	Width		Capacity		Weight		Fill %	Long Narrow Undercarriage 4.55 mt (10,000 lb) Reach Boom	
		mm	in	m ³	yd ³	kg	lb		Reach Boom	
									R2.5 (8'2")	R2.9 (9'6")
With CW40 Coupler										
General Duty	B	900	36	0.81	1.06	664	1,463	100	●	●
	B	1050	42	1.00	1.31	711	1,567	100	⊙	⊙
	B	1200	48	1.19	1.56	781	1,721	100	⊖	○
	B	1300	51	1.30	1.70	813	1,791	100	○	○
	B	1400	55	1.43	1.87	863	1,903	100	○	◇
General Duty with Leveling Edge	B	650	26	0.70	0.92	567	1,249	100	●	●
	B	800	31	0.68	0.89	614	1,353	100	●	●
	B	1200	47	1.19	1.56	787	1,734	100	⊖	○
	B	1400	55	1.43	1.87	855	1,884	100	○	◇
Heavy Duty	B	600	24	0.46	0.61	618	1,363	100	●	●
	B	1200	48	1.19	1.56	886	1,953	100	⊖	○
	B	1300	52	1.30	1.71	944	2,081	100	○	○
Ditch Cleaning	B	2100	83	1.29	1.69	792	1,746	100	⊖	○
	B	2100	83	1.46	1.91	809	1,784	100	○	◇
	B	1800	72	1.50	1.96	775	1,709	100	○	◇
	B	1800	72	1.50	1.96	737	1,624	100	○	○
	B	2100	83	1.76	2.31	864	1,905	100	◇	◇
Ditch Cleaning Tilt	B	2000	79	1.23	1.61	1161	2,560	100	○	◇
								kg	2650	2455
								lb	5,842	5,412
With CW40s Coupler										
General Duty	B	600	24	0.46	0.61	508	1,119	100	●	●
	B	750	30	0.64	0.84	592	1,305	100	●	●
	B	900	36	0.81	1.06	661	1,457	100	●	●
	B	1300	51	1.30	1.70	810	1,785	100	⊖	○
	B	1400	55	1.43	1.87	845	1,862	100	○	○
Heavy Duty	B	600	24	0.46	0.61	585	1,289	100	●	●
	B	1200	48	1.19	1.56	875	1,928	100	⊖	○
	B	1300	52	1.30	1.70	931	2,052	100	○	○
Ditch Cleaning	B	2000	78	1.22	1.60	815	1,797	100	⊖	○
	B	2200	87	1.36	1.78	880	1,940	100	○	○
Ditch Cleaning Tilt	B	2000	79	1.23	1.61	1142	2,518	100	○	◇
								kg	2672	2478
								lb	5,890	5,463

The above loads are in compliance with hydraulic excavator standard EN474-5:2006+A3:2013, they do not exceed 87% of hydraulic lifting capacity or 75% of tipping capacity with front linkage fully extended at ground line with bucket curled.

Capacity based on ISO 7451:2007.

Bucket weight with General Duty tips.

Maximum Material Density:

- 2100 kg/m³ (3,500 lb/yd³)
- ⊙ 1800 kg/m³ (3,000 lb/yd³)
- ⊖ 1500 kg/m³ (2,500 lb/yd³)
- 1200 kg/m³ (2,000 lb/yd³)
- ◇ 900 kg/m³ (1,500 lb/yd³)

Caterpillar recommends using appropriate work tools to maximize the value customers receive from our products. Use of work tools, including buckets, which are outside of Caterpillar's recommendations or specifications for weight, dimensions, flows, pressures, etc. may result in less-than-optimal performance, including but not limited to reductions in production, stability, reliability, and component durability. Improper use of a work tool resulting in sweeping, prying, twisting and/or catching of heavy loads will reduce the life of the boom and stick.

(continued on next page)

320 GC Narrow Hydraulic Excavator Specifications

Bucket Specifications and Compatibility (continued)

	Linkage	Width		Capacity		Weight		Fill %	Long Narrow Undercarriage 4.55 mt (10,000 lb)	
		mm	in	m ³	yd ³	kg	lb		Reach Boom	
									R2.5 (8'2")	R2.9 (9'6")
Pin-On, TRS18 S70										
Grading	B	1600	63	1.00	1.31	691	1,523	100	⊖	○
	B	1800	71	1.10	1.44	758	1,671	100	○	○
Digging	B	1150	45	0.90	1.18	778	1,715	100	⊖	○
	B	1250	49	1.10	1.44	850	1,874	100	○	◇
Trenching	B	600	24	0.55	0.72	460	1,014	100	●	●
								kg	2221	2027
								lb	4,896	4,469
With S70, TRS18 S70										
Grading	B	1600	63	1.00	1.31	691	1,523	100	○	◇
	B	1800	71	1.10	1.44	758	1,671	100	◇	◇
Digging	B	1150	45	0.90	1.18	778	1,715	100	○	◇
	B	1250	49	1.10	1.44	850	1,874	100	◇	X
Trenching	B	600	24	0.55	0.72	460	1,014	100	●	●
								kg	1966	1772
								lb	4,334	3,906
Pin-On, TRS18 HCS70/55										
Grading	B	1600	63	1.00	1.31	694	1,530	100	⊖	○
	B	1800	71	1.10	1.44	761	1,678	100	○	◇
Digging	B	1150	45	0.90	1.18	774	1,706	100	⊖	○
	B	1250	49	1.10	1.44	846	1,865	100	○	◇
Trenching	B	600	24	0.55	0.72	482	1,063	100	●	●
								kg	2125	1931
								lb	4,684	4,257
HCS70/55, TRS18 HCS70/55										
Grading	B	1600	63	1.00	1.31	694	1,530	100	◇	X
	B	1800	71	1.10	1.44	761	1,678	100	◇	X
Digging	B	1150	45	0.90	1.18	774	1,706	100	◇	X
	B	1250	49	1.10	1.44	846	1,865	100	X	X
Trenching	B	600	24	0.55	0.72	482	1,063	100	●	⊙
								kg	1718	1524
								lb	3,787	3,360

The above loads are in compliance with hydraulic excavator standard EN474-5:2006+A3:2013, they do not exceed 87% of hydraulic lifting capacity or 75% of tipping capacity with front linkage fully extended at ground line with bucket curled.

Capacity based on ISO 7451:2007.

Bucket weight with General Duty tips.

Maximum Material Density:

- 2100 kg/m³ (3,500 lb/yd³)
- ⊙ 1800 kg/m³ (3,000 lb/yd³)
- ⊖ 1500 kg/m³ (2,500 lb/yd³)
- 1200 kg/m³ (2,000 lb/yd³)
- ◇ 900 kg/m³ (1,500 lb/yd³)
- X Not Recommended

Caterpillar recommends using appropriate work tools to maximize the value customers receive from our products. Use of work tools, including buckets, which are outside of Caterpillar's recommendations or specifications for weight, dimensions, flows, pressures, etc. may result in less-than-optimal performance, including but not limited to reductions in production, stability, reliability, and component durability. Improper use of a work tool resulting in sweeping, prying, twisting and/or catching of heavy loads will reduce the life of the boom and stick.

320 GC Narrow Hydraulic Excavator Specifications

Attachments Offering Guide

Not all Attachments are available in all regions. Consult your Cat dealer for configurations available in your region.

Match
 * Working range front only
 † Allowed usage on machine less than 50%
 No Match

PIN-ON ATTACHMENTS

Undercarriage		Long Narrow	
Counterweight		4.55 mt (10,000 lb)	
Boom Type		Reach	
Stick Length		R2.5 (8'2")	R2.9 (9'6")
Hydraulic Hammers	H115 S	✓	✓
	H120 GC S	✓	✓
	H120 S	✓	✓
	H130 GC S	✓†	
	H130 S	✓	✓†
Multi-Processors	MP318 Concrete Cutter Jaw	✓	✓
	MP318 Demolition Jaw	✓	✓
	MP318 Pulverizer Jaw	✓	✓
	MP318 Shear Jaw	✓	✓
	MP318 Universal Jaw	✓	✓
Demolition and Sorting Grapples	G317 GC	✓	✓
	G318	✓	✓
	G318 WH-800	✓	✓
	G318 WH-1100	✓	✓
Mobile Scrap and Demolition Shears	S3025 Flat Top	✓	✓*
Pulverizers	P218 Secondary Pulverizer	✓	✓
	P318 Primary Pulverizer	✓	✓
Compactors (Vibratory Plate)	CVP110	✓	✓
Rotary Cutters	RC20	✓	✓

(continued on next page)

320 GC Narrow Hydraulic Excavator Specifications

Attachments Offering Guide *(continued)*

Not all Attachments are available in all regions. Consult your Cat dealer for configurations available in your region.

1800 kg/m³ (3,000 lb/yd³)
 1200 kg/m³ (2,000 lb/yd³)
 600 kg/m³ (1,000 lb/yd³)
 No Match

PIN-ON ATTACHMENTS *(continued)*

Undercarriage		Long Narrow	
Counterweight		4.55 mt (10,000 lb)	
Boom Type		Reach	
Stick Length		R2.5 (8'2")	R2.9 (9'6")
Orange Peel Grapples	GSH420-500	●	●
	GSH420-600	●	●
	GSH420-750	●	●
	GSH425-750	○	○
	GSH425-950	○	
	GSH425-1150		
	GSH520-500	●	●
	GSH520-600	●	●
	GSH520-750	●	○
	GSH525-750	○	
	GSH525-950		
	GSV420-400	●	●
	GSV420-500	●	●
	GSV420-600	●	●
	GSV420-750	●	●
	GSV420-1250	◇	◇
	GSV425-600	●	●
	GSV425-750	○	○
	GSV425-950	○	
	GSV425-1150		
	GSV425-1550	◇	
	GSV520 GC-400	●	●
	GSV520 GC-500	●	●
	GSV520 GC-600	●	●
	GSV520 GC-750	●	●
	GSV520-400	●	●
	GSV520-500	●	●
	GSV520-600	●	●
	GSV520-750	●	●
	GSV525-600	●	○
	GSV525-750	○	
	GSV525-950		
Clamshell Grapples	CTV15-1000	○	○
	CTV15-1200	○	

(continued on next page)

320 GC Narrow Hydraulic Excavator Specifications

Attachments Offering Guide *(continued)*

Not all Attachments are available in all regions. Consult your Cat dealer for configurations available in your region.

Match
 * Working range front only
 † Allowed usage on machine less than 50%
 No Match

CAT PIN GRABBER COUPLER ATTACHMENTS

Undercarriage		Long Narrow	
Counterweight		4.55 mt (10,000 lb)	
Boom Type		Reach	
Stick Length		R2.5 (8'2")	R2.9 (9'6")
Hydraulic Hammers	H115 S	✓	✓
	H120 GC S	✓†	✓†
	H120 S	✓†	✓†
	H130 GC S	✓*†	
	H130 S	✓†	✓†
Multi-Processors	MP318 Concrete Cutter Jaw	✓	✓*
	MP318 Demolition Jaw	✓	✓*
	MP318 Pulverizer Jaw	✓*	
	MP318 Shear Jaw	✓	✓*
	MP318 Universal Jaw	✓*	
Demolition and Sorting Grapples	G317 GC	✓	✓
	G318	✓	✓*
	G318 WH-800	✓	✓*
	G318 WH-1100		
Mobile Scrap and Demolition Shears	S3025 Flat Top		
Pulverizers	P218 Secondary Pulverizer	✓*	
	P318 Primary Pulverizer	✓*	
Compactors (Vibratory Plate)	CVP110	✓	✓
Rotary Cutters	RC20	✓	✓

(continued on next page)

320 GC Narrow Hydraulic Excavator Specifications

Attachments Offering Guide *(continued)*

Not all Attachments are available in all regions. Consult your Cat dealer for configurations available in your region.

Match
 * Working range front only
 † Allowed usage on machine less than 50%
 No Match

CW-40s DEDICATED COUPLER ATTACHMENTS

Undercarriage		Long Narrow	
Counterweight		4.55 mt (10,000 lb)	
Boom Type		Reach	
Stick Length		R2.5 (8'2")	R2.9 (9'6")
Hydraulic Hammers	H115 S	✓	✓
	H120 GC S	✓†	✓†
	H120 S	✓†	✓†
	H130 S	✓†	✓†
Multi-Processors	MP318 Concrete Cutter Jaw	✓	✓
	MP318 Demolition Jaw	✓	✓
	MP318 Pulverizer Jaw	✓	✓*
	MP318 Shear Jaw	✓	✓
	MP318 Universal Jaw	✓	✓
Demolition and Sorting Grapples	G317 GC	✓	✓
	G318	✓	✓
	G318 WH-800	✓	✓
	G318 WH-1100	✓	✓*
Mobile Scrap and Demolition Shears	S3025 Flat Top	✓*	
Pulverizers	P218 Secondary Pulverizer	✓	✓*
	P318 Primary Pulverizer	✓	✓*
Compactors (Vibratory Plate)	CVP110	✓	✓
Rotary Cutters	RC20	✓	✓

(continued on next page)

320 GC Narrow Hydraulic Excavator Specifications

Attachments Offering Guide *(continued)*

Not all Attachments are available in all regions. Consult your Cat dealer for configurations available in your region.

Match
 * Working range front only
 † Allowed usage on machine less than 50%
 No Match

CW-40 DEDICATED COUPLER ATTACHMENTS

Undercarriage		Long Narrow	
Counterweight		4.55 mt (10,000 lb)	
Boom Type		Reach	
Stick Length		R2.5 (8'2")	R2.9 (9'6")
Hydraulic Hammers	H115 S	✓	✓
	H120 GC S	✓†	✓†
	H120 S	✓†	✓†
	H130 GC S	✓*†	
	H130 S	✓†	✓†
Multi-Processors	MP318 Concrete Cutter Jaw	✓	✓
	MP318 Demolition Jaw	✓	✓
	MP318 Pulverizer Jaw	✓	✓*
	MP318 Shear Jaw	✓	✓
	MP318 Universal Jaw	✓	✓
Demolition and Sorting Grapples	G317 GC	✓	✓
	G317 GC fixed CAN	✓	✓
	G318	✓	✓
	G318 fixed CAN	✓	✓
	G318 WH-800	✓	✓
	G318 WH-1100	✓	✓*
Mobile Scrap and Demolition Shears	S3025 Flat Top	✓*	
Pulverizers	P218 Secondary Pulverizer	✓	✓*
	P318 Primary Pulverizer	✓	✓*
Compactors (Vibratory Plate)	CVP110	✓	✓
Rotary Cutters	RC20	✓	✓

(continued on next page)

320 GC Narrow Hydraulic Excavator Specifications

Attachments Offering Guide *(continued)*

Not all Attachments are available in all regions. Consult your Cat dealer for configurations available in your region.

Match
 * Working range front only
 † Allowed usage on machine less than 50%
 No Match

S70 DEDICATED COUPLER ATTACHMENTS

Undercarriage		Long Narrow	
Counterweight		4.55 mt (10,000 lb)	
Boom Type		Reach	
Stick Length		R2.5 (8'2")	R2.9 (9'6")
Hydraulic Hammers	H115 S	✓	✓
	H120 GC S	✓†	✓†
	H120 S	✓†	✓†
	H130 S	✓†	✓†
Multi-Processors	MP318 Concrete Cutter Jaw	✓	✓*
	MP318 Demolition Jaw	✓	✓*
	MP318 Pulverizer Jaw	✓	
	MP318 Shear Jaw	✓	✓
	MP318 Universal Jaw	✓	✓*
Demolition and Sorting Grapples	G317 GC	✓	✓
	G318	✓	✓*
	G318 WH-800	✓	✓
	G318 WH-1100	✓*	
Mobile Scrap and Demolition Shears	S3025 Flat Top		
Pulverizers	P218 Secondary Pulverizer	✓	✓*
	P318 Primary Pulverizer	✓	
Compactors (Vibratory Plate)	CVP110	✓	✓
Rotary Cutters	RC20	✓	✓

(continued on next page)

320 GC Narrow Hydraulic Excavator Specifications

Attachments Offering Guide *(continued)*

Not all Attachments are available in all regions. Consult your Cat dealer for configurations available in your region.

Match
 * Working range front only
 † Allowed usage on machine less than 50%
 No Match

HCS70 COUPLER ATTACHMENTS

Undercarriage		Long Narrow	
Counterweight		4.55 mt (10,000 lb)	
Boom Type		Reach	
Stick Length		R2.5 (8'2")	R2.9 (9'6")
Hydraulic Hammers	H115 S	✓	✓
	H120 S	✓†	✓†
	H130 S	✓†	✓†
Multi-Processors	MP318 Concrete Cutter Jaw	✓	
	MP318 Demolition Jaw	✓	
	MP318 Pulverizer Jaw	✓*	
	MP318 Shear Jaw	✓	✓*
	MP318 Universal Jaw	✓	
Demolition and Sorting Grapples	G317 GC	✓	✓
	G318	✓	
	G318 WH-800	✓	✓*
	G318 WH-1100		
Mobile Scrap and Demolition Shears	S3025 Flat Top		
Pulverizers	P218 Secondary Pulverizer	✓*	
	P318 Primary Pulverizer	✓*	
Compactors (Vibratory Plate)	CVP110	✓	✓
Rotary Cutters	RC20	✓	✓

(continued on next page)

320 GC Narrow Hydraulic Excavator Specifications

Attachments Offering Guide (continued)

Not all Attachments are available in all regions. Consult your Cat dealer for configurations available in your region.

Match
 * Working range front only
 † Allowed usage on machine less than 50%
 No Match

HCS70/55 COUPLER ATTACHMENTS

Undercarriage		Long Narrow	
Counterweight		4.55 mt (10,000 lb)	
Boom Type		Reach	
Stick Length		R2.5 (8'2")	R2.9 (9'6")
Hydraulic Hammers	H115 S	✓	✓
	H120 S	✓†	✓†
	H130 S	✓†	✓†
Multi-Processors	MP318 Concrete Cutter Jaw	✓*	
	MP318 Demolition Jaw	✓*	
	MP318 Pulverizer Jaw	✓*	
	MP318 Shear Jaw		
	MP318 Universal Jaw	✓	✓*
Demolition and Sorting Grapples	G317 GC	✓*	✓
	G318	✓*	
	G318 WH-800	✓	✓*
	G318 WH-1100		
Mobile Scrap and Demolition Shears	S3025 Flat Top		
Pulverizers	P218 Secondary Pulverizer		
	P318 Primary Pulverizer		
Compactors (Vibratory Plate)	CVP110	✓	✓
Rotary Cutters	RC20	✓	✓

BOOM-MOUNT ATTACHMENTS

Undercarriage		Long Narrow	
Counterweight		4.55 mt (10,000 lb)	
Boom Type		Reach	
Mobile Scrap and Demolition Shears	S2050	✓	
	S3035 Flat Top		✓

320 GC Narrow Standard and Optional Equipment

Standard and Optional Equipment

Standard and optional equipment may vary. Consult your Cat dealer for details.

	Standard	Optional		Standard	Optional
CAB			ENGINE		
ROPS	✓		Cat C4.4 single turbo engine	✓	
High-resolution 203 mm (8") LCD touchscreen monitor	✓		Two selectable power modes	✓	
Auto bi-level air conditioner	✓		Auto engine speed control	✓	
Jog dial and shortcut keys for monitor control	✓		Auto engine idle shutdown	✓	
Keyless push-to-start engine control	✓		Work up to 3000 m (9,842.5 ft) above sea level without engine power de-rating	✓	
Height-adjustable console, three steps with tool	✓		52° C (125° F) high-ambient cooling capacity	✓	
Fixed left-side console	✓		Cold starting capability for -32° C (-25° F)	✓	
Air-suspension seat	✓		Double element air filter with integrated pre-cleaner	✓	
51 mm (2") seat belt	✓		Electric fuel priming pump	✓	
DAB radio with Bluetooth (includes USB/Aux ports)	✓		Electric cooling fans with auto-reverse function	✓	
12V DC outlets	✓		HYDRAULIC SYSTEM		
Document storage	✓		Boom and stick regeneration circuits	✓	
Beverage holder	✓		Boom/stick lowering check valves	✓	
Cup holder	✓		SmartBoom™		✓
Openable two-piece front window	✓		Electronic main control valve	✓	
Rear window emergency exit	✓		Auto warm up	✓	
Radial wiper with washer	✓		Auto two-speed travel	✓	
Openable steel hatch	✓		Boom and stick drift reduction valve	✓	
LED dome light	✓		Element type main hydraulic filter	✓	
Roller front sunscreen	✓		Slider joysticks	✓	
Roller rear sunscreen		✓	Tandem type electronic main pump	✓	
Washable floor mat	✓		Advanced Tool Control	✓	
Beacon ready	✓		Medium pressure circuit		✓
			Quick coupler circuit for Cat Pin Grabber and CW Dedicated	✓	

(continued on next page)

320 GC Narrow Standard and Optional Equipment

Standard and Optional Equipment *(continued)*

Standard and optional equipment may vary. Consult your Cat dealer for details.

	Standard	Optional		Standard	Optional
UNDERCARRIAGE AND STRUCTURES			CAT TECHNOLOGY		
500 mm (20 in) triple grouser track shoes	✓		VisionLink®	✓*	
Segmented track guiding guards		✓	VisionLink Productivity		✓
Bottom guard	✓		Remote Flash	✓	
Swivel guard		✓	SERVICE AND MAINTENANCE		
Travel motor guards	✓		Scheduled Oil Sampling (S·O·S SM) ports	✓	
Grease lubricated track links	✓		Ground-level second dipstick for engine oil	✓	
4.55 mt (10,000 lb) counterweight	✓		Side entry to service platform	✓	
Semi-HD swing frame		✓	Integrated vehicle health management system	✓	
Base frame with HD track rollers and standard carrier rollers	✓		SAFETY AND SECURITY		
Final drive with bio oil capable travel motor	✓		Auto hammer stop	✓	
BOOM, STICKS AND LINKAGES			Rear and right-hand-sideview cameras		✓
5.7 m (18'8") Reach boom	✓		Cab mirror for RH side track edge	✓	
2.9 m (9'6") Reach stick		✓	Cat PL161 attachment locator		✓
2.5 m (8'2") Reach stick		✓	Neutral lever (lock out) for all controls	✓	
Bucket linkage, B1-family with lifting eye		✓	Anti-skid plate and countersunk bolts on service platform	✓	
Bucket linkage, B1-family without lifting eye		✓	Ground-level accessible secondary engine shutoff switch	✓	
ELECTRICAL SYSTEM			Lockable disconnect switch	✓	
1,000 CCA maintenance-free batteries (×2)	✓		Swing alarm		✓
Centralized electrical disconnect switch	✓		RH handrail and handhold	✓	
Programmable time-delay LED working lights	✓		OPG guards		✓
LED chassis light, boom lights, cab lights	✓		Inspection lighting		✓

*Connect subscription only. Additional subscriptions are available. Contact your Cat dealer for availability.

320 GC Narrow Attachments

Dealer Installed Kit and Attachments

Attachments may vary. Consult your Cat dealer for details.

CAB

- Lower radial wiper
- Rain protector plus cab light cover
- Polycarbonate roof hatch
- Sun visor, slider
- Laminated P5A glass front windshield
- LH/RH electrical pedal for tool control
- Armrest kit
- Dual exit rear window kit
- 75 mm (3") retractable seat belt
- Lunch box net
- Rear storage
- Tool box

GUARDS

- Swivel guard
- Side rubber bumper guard
- Operator Protective Guards
- Mesh guard full front
- Mesh guard half front
- Full protecting vandalism guard

MAINTENANCE

- Duct ready kit

SAFETY AND SECURITY

- Bluetooth receiver

For more complete information on Cat products, dealer services, and industry solutions, visit us on the web at www.cat.com

© 2023 Caterpillar
All rights reserved

Materials and specifications are subject to change without notice. Featured machines in photos may include additional equipment. See your Cat dealer for available options.

CAT, CATERPILLAR, LET'S DO THE WORK, their respective logos, "Caterpillar Corporate Yellow," the "Power Edge" and Cat "Modern Hex" trade dress as well as corporate and product identity used herein, are trademarks of Caterpillar and may not be used without permission. VisionLink is a trademark of Caterpillar Inc., registered in the United States and in other countries.

AEXQ2215-07 (08-2023)
Replaces AEXQ2215-06
Build Number: 07G
(Europe)

