



Standby 200 kW, 250 kVA
 Prime 182 kW, 228 kVA
 U.S. EPA Tier 4 Final
 60 Hz
 1800 RPM

Image shown may not reflect actual configuration

Specifications

Generator	Frequency	Voltage	Standby kW (kVA)	Prime kW (kVA)	Phase	Amp (A)
Standard	60 Hz	480/277V	200 (250)	182 (228)	3-phase	273.64
		208/120V	200 (250)	182 (228)	3-phase	631.48
		240/120V	150 (150)	136 (136)	1-phase	566.67
Optional	60 Hz	600V/349V	200 (250)	182 (228)	3-phase	218.91
		480V/277V	200 (250)	182 (228)	3-phase	273.64
		208/120V	TBD	163 (204)	3-phase	565.55
		240/120V	TBD	120 (120)	1-phase	500.00

Cat® C7.1 ACERT™ Diesel Engine	Metric	Imperial (English)
Configuration	Inline 6, 4-Stroke Diesel	
Bore	105 mm	4.13 in
Stroke	135 mm	5.3 in
Displacement	7.01 L	427.7 in ³
Aspiration	Turbocharged-Aftercooled	
Compression Ratio	16.5:1	
Engine rpm	1800	
Governor Type	Electronic	

Features & Benefits

Fuel/Emissions Strategy

- Meets U.S. EPA Tier 4 Final emission standards and CARB certified for non-road mobile applications at all 60 Hz ratings
- Requires Ultra Low Sulfur Diesel (ULSD) fuel

Quality

- Factory designed and production tested to assure customer satisfaction
- Manufactured in ISO 9001:2000 certified facility

Cat C7.1 ACERT Diesel Engine

- Four-stroke diesel engine with ACERT offers consistent performance and excellent fuel economy
- Series turbocharged with smart wastegate for fast response, high power, and increased torque
- Low ownership costs enabled by multi-vee belts and service-free hydraulic tappets
- Oil and fuel filter change intervals: 500 hrs

Aftertreatment / Clean Emissions Equipment

- Package-mounted Aftertreatment module consists Diesel Oxidation Catalyst (DOC), Diesel Particulate Filter (DPF), and Selective Catalytic Reduction (SCR)
- Passive regeneration is transparent to operator
- No requirement for ash servicing
- Service free for life of the engine
- DEF tank provides > 24 hrs run time
- Electrically heated DEF lines

Cat LC Series Generator

- Matched to the performance and output characteristics of Cat engines
- UL 1446 Recognized Class H insulation

Cat EMCP 4.2B Control Panel

- Electronic control panel provides power metering, protective relaying, engine and generator parameter viewing, and expanded AC metering
- Graphical display (3.8 in.) denotes text alarm/ event descriptions, set points, engine and generator monitoring, and is visible in all lighting conditions
- Simple, user-friendly interface and navigation
- Automatic set-point adjustment integrated with voltage and frequency selection
- Integrates with the Cat Integrated Voltage Regulator (IVR) to provide precise control, excellent black loading, and constant voltage.
- PLC Functionality
- Load histogram (real power) – monitors utilization by tracking the amount of time generator %kW is within predefined ranges
- Enhanced overcurrent protection – generator thermal damage curve

Standard Controls and Power Distribution

- Three-position switch for easy selection of desired output voltage (480/277V 3-phase, 208/120V 3-phase, or 240/120V 1-phase)
- Controls, sockets, and power distribution all accessible via rear access door
- Hinged door over main buss bars with safety switch to trip breaker

Sound-attenuated Enclosure

- Provides excellent weather protection and allows for a quiet package operation with less than 72 dBA sound levels at full load, while offering excellent service access with multiple doors and access panels
- Galvanealed sheet steel body panels for improved corrosion resistance
- Coolant and oil drains piped to exterior of enclosure along with auxiliary fuel connections are all conveniently located on one side of the enclosure for easy access
- Single point lifting

Fuel System

- Provides 24-hour runtime @ 75% prime
- Meets UL 142, ULC 601, and UN31A (Transport Canada)

Rental-Ready Design Features

- 110% spill containment of all engine fluids
- Battery Charger
- Generator Anti-condensation Heater
- Engine Block Heater
- Provides 43°C ambient capability @ full rating

Asset Monitoring and Management

- Cat Connect hardware provides remote equipment monitoring via cellular network
- Provides operational status, alarms, and engine and generator set parameters
- Flexible and customer-configurable user website
- GPS provides asset location and geo-fencing

Options

- Battery Charger (10A, NFPA Complaint)
- Trailer (Electric or Hydraulic Brakes)
- Paralleling Package with EMCP 4.4
- 600 V Generator
- 208V 3-phase NEMA Sockets
- Camlock Distribution System
- Retail Version (with or without enclosure)

Standard Equipment

Engine

- Cat C7.1, heavy-duty, diesel engine meets U.S. EPA Tier 4 Final emissions standards
- CEM mounted off engine
- Block heater, 110-120 VAC, 1000 Watt
- Requires Ultra Low Sulfur Diesel (ULSD) fuel
- Engine electrical system:
 - 24V, DC electrical system
 - 115A, DC charging alternator
 - Electronic governor and engine controls
 - Oil pressure, coolant temperature, and coolant level shutdown sensors
- Engine filtration system:
 - Cartridge-type air filter with service indicator
 - Cartridge-type fuel filter with upstream pre- filter and water separator
 - Spin-on, full-flow lube oil filter; requires API CJ-4 lube oil

Generator and Voltage Regulation

- Screen protected and drip-proof (IP23), self-regulating, 12-lead, 4-pole, brushless generator
- Sealed-for-life bearing
- PMG Excitation
- Voltage selection switch mounted to generator terminal box. 3-position with 480V generator and 4-position with 600V generator.
- Anti-condensation, space heater, 250-Watt, 110-120 VAC
- Insulation system:
 - Class H insulation system
 - Windings impregnated in a thermo-setting moisture-, oil-, and acid-resisting varnish
 - Heavy coat of anti-tracking varnish for additional protection against moisture or condensation
- IVR:
 - EMCP provides voltage regulation
 - Improved transient response performance capability using patented Transient Load Relief (TRL) feature

Generator Set Packaging

- Base frame with integral double-wall fuel tank and leak detection switch:
 - Heavy-duty, fabricated steel base frame with specially-designed lifting points
 - Integral containment tray atop base frame
- Canopy:
 - Sound attenuated to 72 dBA at 7m (23 ft)
 - Two doors on each side, two rear doors for power distribution and control panel access
- Cooling system:
 - Cooling system provides 43°C (109°F) ambient capability at 500 m (1,640 ft) above sea level
- Electrical system:
 - 24V, DC electrical system
 - 2x 850 CCA, maintenance-free, wet batteries
 - Battery disconnect switch, lockable
 - Solar battery charger with solar array
 - Resettable, switch-style circuit breakers (DC circuit)
 - Battery charger 24V (10A for two isolated batteries; 5A for two batteries linked in series) constant voltage, UL Listed
- Engine and generator mounting:
 - Engine and generator directly coupled by SAE flange
 - Engine flywheel flexibly coupled to the generator rotor, with full torsional analysis completed to ensure no harmful vibration will occur in the assembly
 - Anti-vibration pads between engine/generator feet and base frame
- Fuel system:
 - 24 hour runtime @ 75% prime load
 - 2-position valves and external ports (3/4-16 JIC) allow connection of an auxiliary fuel source
- CSA 22.2 Certified

Standard Equipment (continued)

Generator Controls and Power Distribution

- EMCP 4.2B, digital generator set controller, mounted behind a hinged, lockable door with viewing window
- Manually-operated Circuit breaker: 3-pole molded case breaker, 800A, UL Listed and CSA with shunt trip and LSIG trip unit
- Safety switch on lower access door – trips breaker if door is opened
- Two-wire, remote start-stop terminals
- Customer auxiliary power connections:
 - Three – 250V, 50A California-style, twist lock receptacles
 - Two – 120V, 20A duplex receptacles with GFCI*
 - Each receptacle protected by a miniature circuit breaker, which also acts as an on/off switch
- Main customer connections:
 - Tin-plated copper bus bars with phase separators, located behind a protective door with shunt trip switch
 - Bus bars sized for full load capacity of generator set at 0.8 power factor
- Cat Connect telematics including roof mounted antenna for cellular and GPS

Quality and Product Support

- Factory load-testing of complete generator set
- Factory test certificate available upon request
- Equipment meets the following standards: BS 4999, BS 5000, BS 5514, IEC 60034, EN 61000-6, NEMA MG 1-22 & CSA
- Full set of operation and maintenance manuals

* Voltage at receptacle is 120V when switch is in 240/120 and 208 positions, and 139V in 480V position

** All receptacles are switched off when voltage selector switch is in 600V position.

‡ Available in 2019

Optional Equipment

- Paralleling Controls
 - EMCP 4.4 paralleling controller
 - Electrically operated circuit breaker with undervoltage trip and LSIG trip unit
 - MGDL (Ethernet comms) for paralleling interconnect with other units
- NEMA receptacles (2) 208V, 30A
- NFPA 110 complaint battery charger 10A
- Camlock distribution system ‡
- 600V Generator with 4-position voltage selector switch** ‡



Technical Data

Cat Generator		
Frame size	LC5034H	
Pitch	2/3	
No. of poles	4	
Insulation	Class H	
Enclosure	Drip proof IP23	
Voltage regulator	3-phase sensing with volts-per-hertz	
Frequency regulation	0.5% at steady state from no load to full load	
Wave form deviation	THD <2%	
Overspeed limit	2250 rpm	
Available Voltages	Standard	Switchable voltage output: 480/277V, 3-phase; 208/120V, 3-phase; 240/120V, single-phase
	Optional	Switchable voltage output: 600/349V, 3-phase; 480/277V, 3-phase; 208/120V, 3-phase; 240/120V, single-phase

Cat Generator Set – 1800 rpm/60 Hz		
	Units	Prime
Power Rating	kW (kVA)	182 (227.5)
Performance Number	P4350C	
Performance Specification		
Lubricating System Capacity oil	L (gal)	16 (4.3)
Fuel System Fuel consumption***		
100% Load	L/hr (gal/hr)	56 (14.7)
75% Load	L/hr (gal/hr)	41 (10.8)
50% Load	L/hr (gal/hr)	28 (7.4)
Fuel tank capacity	L (gal)	992 (262)
Fuel Run Time @ 75% Prime Load	Hours	>24
DEF System DEF consumption		
100% Load	L/hr (gal/hr)	1.42 (0.38)
75% Load	L/hr (gal/hr)	1.11 (0.29)
50% Load	L/hr (gal/hr)	0.68 (0.18)
DEF tank capacity	L (gal)	46 (12.2)
DEF Run Time @ All Power Settings	Hours	>24
Cooling System Radiator system capacity including engine Heat rejected to coolant at rated power	L (U.S. gal) kW (Btu/min)	38.7 (10.2) 135 (7660)



Technical Data (continued)

Cat Generator Set – 1800 rpm/60 Hz		
	Units	Prime
Air Requirements @ 1800 rpm, 100% load		
Combustion air flow	m ³ /min (cfm)	14 (494)
Maximum dirty air cleaner restriction	kPa (inches H ₂ O)	6.23 (25)
Noise Rating*** with enclosure at 7 meters (23 feet)	dB(A)	72

***Package fuel consumption and sound levels are for reference only.

Dimensions and Weights					
Model	Length mm (in)	Width mm (in)	Height mm (in)	With Lube Oil & Coolant Kg (lb)	With Fuel, Lube Oil & Coolant Kg (lb)
XQ230	4,120 (162.2)	1,595 (62.8)	1,994 (78.5)	3,828 (8,432)	4,720 (10,405)
XQ230 with trailer (electric brakes)	5,959 (234.6)	2,184 (86)	2,347 (92.4)	4,501 (9,902)	5,386 (11,875)
XQ230 with trailer (hydraulic brakes)	5,959 (234.6)	2,184 (86)	2,347 (92.4)	4,510 (9,922)	5,395 (11,895)

General Layout Dimensions

Dimensions in millimeters (inches)

Shown with optional trailer

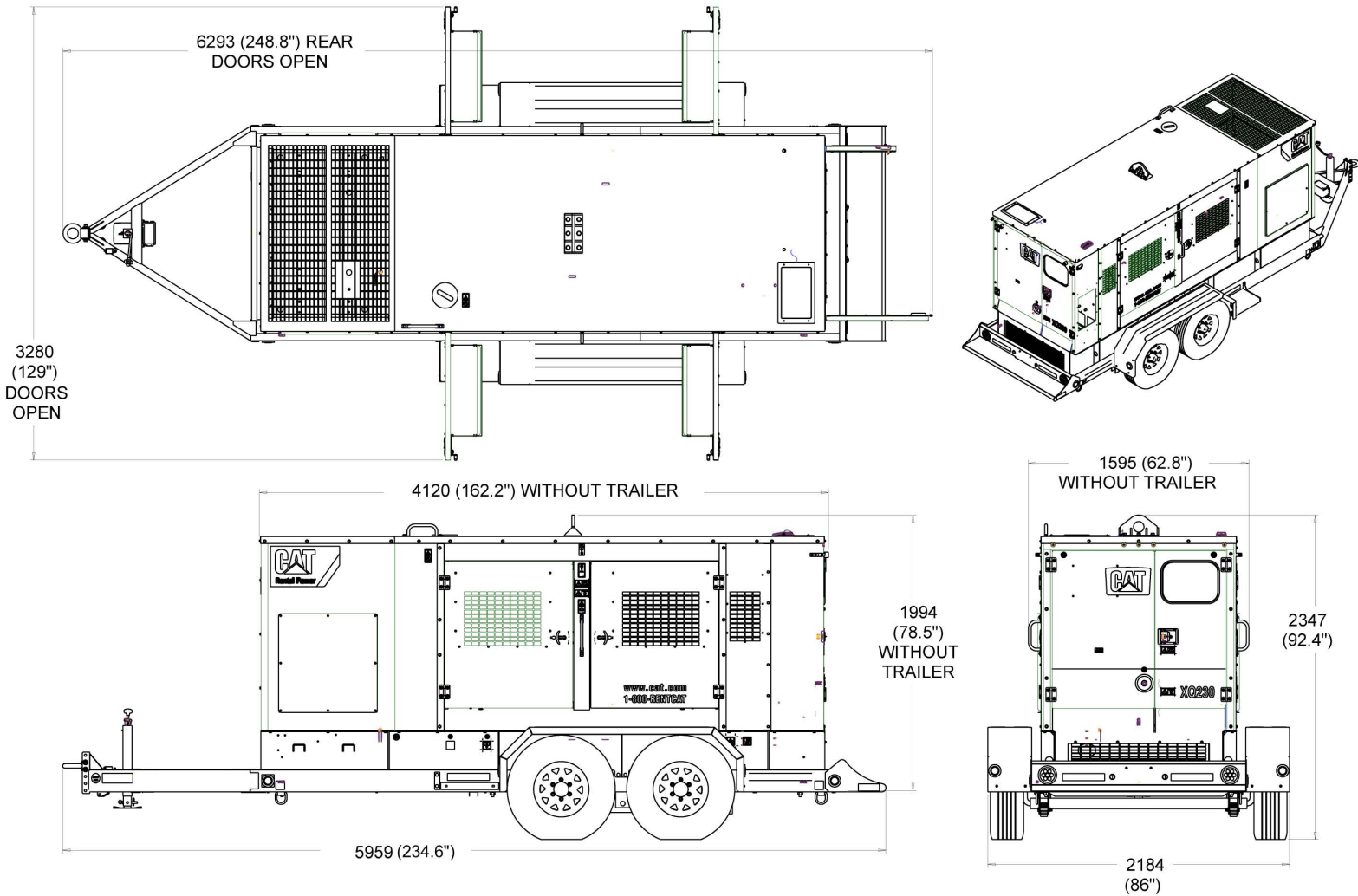

Control Panel and Power Distribution Layout

Item	Description
1	Steel enclosure with hinged, lockable door (not shown)
2	Circuit breakers for receptacles
3	Emergency stop
4	Single-phase GFCI duplex receptacles (20A @ 120V)
5	Two-wire remote start terminals
6	Single-phase, California-style, twist-lock receptacles, 50A @ 208V phase-to-phase, 120V phase to neutral, or 240/120 single-phase when in that voltage position
7	Single-phase, NEMA locking input receptacle, (30A @ 120V) to power block heater, battery charger and generator space heater
8	HEST and DFP Lamp
9	Glow plug lamp
10	EMCP 4.2B digital generator set controller
11	Cat ET service tool connector
12	Manually operated circuit breaker, 3 pole, molded case, LSIG, 800A
13	Main bus connection (bus bars attached to breaker) behind door
14	3-phase NEMA locking receptacles, 208V (optional)
15	Electrically operated circuit breaker, 3 pole, molded case, LSIG, 800A (provided with paralleling option)
16	Alarm horn
17	Circuit breaker open and close pushbuttons (provided with paralleling option)
18	EMCP 4.4 digital generator set controller (provided with paralleling option)

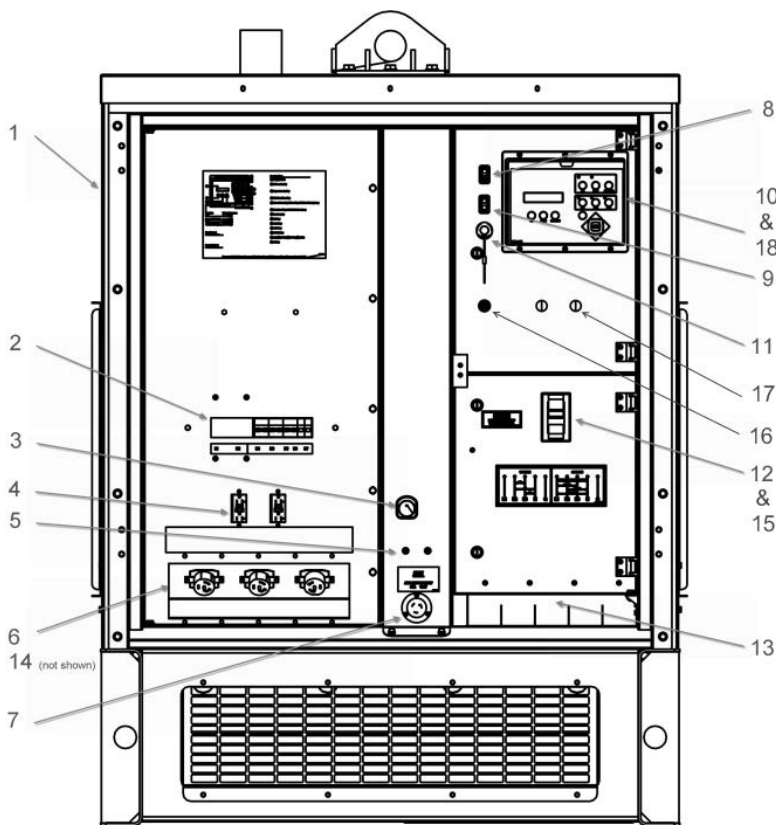

Ratings Definitions and Conditions

Meets or Exceeds International Specifications: AS1359, CSA, IEC60034-1, ISO3046, ISO8528, NEMA MG 1-33.

Prime — Output available with varying load for an unlimited time. Average power output is 70% of the prime power rating. Typical peak demand is 100% of prime rated kW with 10% overload capability for emergency use for a maximum of 1 hour in 12. Overload operation cannot exceed 25 hours per year. Prime power in accordance with ISO3046. Prime ambients shown indicate ambient temperature at 100% load which results in a coolant top tank temperature below the alarm temperature.

Standby — Output available with varying load for the duration of the interruption of the normal source power. Average power output is 70% of the standby power rating. Typical operation is 200 hours per year, with maximum expected usage of 500 hours per year.

Ratings are based on SAE J1349 standard conditions. These ratings also apply at ISO3046 standard conditions.

Fuel rates are based on fuel oil of 35° API [16°C (60°F)] gravity having an LHV of 42 780 kJ/kg (18,390 Btu/lb) when used at 29°C (85°F) and weighing 838.9 g/liter (7.001 lbs/U.S. gal).

Additional ratings may be available for specific customer requirements, contact your Cat representative for details. For information regarding low sulfur fuel and biodiesel capability, please consult your Cat dealer.

www.Cat.com/rentalpower

©2021 Caterpillar
All rights reserved.

Materials and specifications are subject to change without notice. The International System of Units (SI) is used in this publication.

CAT, CATERPILLAR, BUILT FOR IT, their respective logos, ACERT, ADEM, Product Link “Caterpillar Yellow”, the “Power Edge” trade dress as well as corporate and product identity used herein, are trademarks of Caterpillar and may not be used without permission.