



330

Hydraulic Excavator

Technical Specifications

Configurations and features may vary by region. Please consult your Cat® dealer for availability in your area.

Table of Contents

Specifications	2
Engine	2
Swing Mechanism	2
Weights	2
Track	2
Drive	2
Hydraulic System	2
Service Refill Capacities	2
Standards	2
Sound Performance	2
Operating Weights and Ground Pressures	3
Major Component Weights	4
Dimensions	5
Working Ranges and Forces	7
Reach Boom Lift Capacities	
Long Narrow Undercarriage	8
Long Undercarriage	12
Bucket Specifications and Compatibility	17
Attachments Offering Guide	19
Standard and Optional Equipment	33
Dealer Installed Kits and Attachments	35
Cab Options	36
330 Environmental Declaration	37

330 Hydraulic Excavator Specifications

Engine

Engine Model	Cat® C7.1	
Net Power – ISO 9249:2007	204 kW	273 hp
Engine Power – ISO 14396:2002	205 kW	275 hp
Bore	105 mm	4 in
Stroke	135 mm	5 in
Displacement	7.01 L	428 in ³
Biodiesel capability	Up to B20 ⁽¹⁾	

- Meets U.S. EPA Tier 4 Final, EU Stage V, Japan 2014, and Korea Tier 5 emission standards.
- Recommended for use up to 4500 m (14,760 ft) altitude with engine power derate above 3000 m (9,840 ft).
- Net power is tested per ISO 9249:2007. Standards in effect at the time of manufacture.
- Net power available at the flywheel when the engine is equipped with fan, air cleaner, aftertreatment, and alternator with engine speed at 2,200 rpm.
- Rated speed at 2,200 rpm.

⁽¹⁾Cat diesel engines are required to use ULSD (ultra-low sulfur diesel fuel with 15 ppm of sulfur or less) or ULSD blended with the following lower-carbon intensity fuels up to:

- ✓ 20% biodiesel FAME (fatty acid methyl ester)*
- ✓ 100% renewable diesel, HVO (hydrogenated vegetable oil) and GTL (gas-to-liquid) fuels

Refer to guidelines for successful application. Please consult your Cat dealer or “Caterpillar Machine Fluids Recommendations” (SEBU6250) for details.

**Engines with no aftertreatment devices can use higher blends, up to 100% biodiesel.*

Swing Mechanism

Swing Speed	11.50 rpm	
Maximum Swing Torque	110 kN·m	81,132 lbf-ft

Weights

Operating Weight – Long Undercarriage	30 400 kg	67,000 lb
• Reach boom, R3.2 m (10'6") stick, HD 1.76 m ³ (2.30 yd ³) bucket, 600 mm (24") triple grouser shoes and 6700 kg (14,770 lb) counterweight.		
Operating Weight – Long Narrow Undercarriage	31 400 kg	69,200 lb
• Reach boom R3.2 m (10'6") stick, HD 1.76 m ³ (2.30 yd ³) bucket, 600 mm (24") triple grouser shoes and 6700 kg (14,770 lb) counterweight.		

Track

Optional Track Shoes Width	600 mm	24 in
Optional Track Shoes Width	700 mm	28 in
Optional Track Shoes Width	800 mm	31 in
Optional Track Shoes Width	900 mm	35 in
Number of Shoes (each side)	50	
Number of Track Rollers (each side)	9	
Number of Carrier Rollers (each side)	2	

Drive

Gradeability	35°/70%	
Maximum Travel Speed	5.3 km/h	3.3 mph
Maximum Drawbar Pull	248 kN	55,753 lbf

Hydraulic System

Main System – Maximum Flow – Implement	560 L/min (280 × 2 pumps)	148 gal/min (74 × 2 pumps)
Maximum Pressure – Equipment – Normal	35 000 kPa	5,075 psi
Maximum Pressure – Equipment – Heavy Lift Mode/Auto Dig Boost	38 000 kPa	5,510 psi
Maximum Pressure – Travel	35 000 kPa	5,075 psi
Maximum Pressure – Swing	29 800 kPa	4,320 psi
Boom Cylinder – Bore	140 mm	6 in
Boom Cylinder – Stroke	1407 mm	55 in
Stick Cylinder – Bore	150 mm	6 in
Stick Cylinder – Stroke	1646 mm	65 in
Bucket Cylinder – Bore	135 mm	5 in
Bucket Cylinder – Stroke	1156 mm	46 in

Service Refill Capacities

Fuel Tank Capacity	474 L	125.2 gal
Cooling System	25 L	6.6 gal
Engine Oil	25 L	6.6 gal
Swing Drive	10 L	2.6 gal
Final Drive (each)	5.5 L	1.5 gal
Hydraulic System (including tank)	310 L	81.9 gal
Hydraulic Tank	147 L	38.8 gal
DEF Tank	41 L	10.8 gal

Air Conditioning System

The air conditioning system on this machine contains the fluorinated greenhouse gas refrigerant R134a (Global Warming Potential = 1430). The system contains 0.9 kg of refrigerant which has a CO₂ equivalent of 1.287 metric tonnes.

Standards

Brakes	ISO 10265:2008
Cab/ROPS	ISO 12117-2:2008
FOGS (optional)	ISO 10262:1998 Level II

Sound Performance

ISO 6395:2008 (external)	103 dB(A)
ISO 6396:2008 (inside cab)	70 dB(A)

- Hearing protection may be needed when operating with an open operator station and cab (when not properly maintained or doors/windows open) for extended periods or in a noisy environment.

330 Hydraulic Excavator Specifications

Operating Weights and Ground Pressures

	600 mm (24") Triple Grouser Shoes		600 mm (24") HD Triple Grouser Shoes		700 mm (28") HD Triple Grouser Shoes		800 mm (32") Triple Grouser Shoes		900 mm (35") Triple Grouser Shoes	
	Ground Weight		Ground Weight		Ground Weight		Ground Weight		Ground Weight	
	kg (lb)	kPa (psi)	kg (lb)	kPa (psi)	kg (lb)	kPa (psi)	kg (lb)	kPa (psi)	kg (lb)	kPa (psi)
Base machine with 6700 kg (14,770 lb) Counterweight and Long Undercarriage										
Reach Boom + R3.2 (10'6") Stick + 1.76 m ³ (2.30 yd ³) HD Bucket	30 400 (67,000)	58 (8.4)	30 600 (67,500)	58 (8.4)	31 000 (68,400)	51 (7.3)	31 400 (69,200)	45 (6.5)	31 800 (70,100)	40 (5.9)
Base machine with 6700 kg (14,770 lb) Counterweight and Long Narrow Undercarriage										
Reach Boom + R3.2 (10'6") Stick + 1.76 m ³ (2.30 yd ³) HD Bucket	31 400 (67,000)	60 (8.7)	31 600 (69,700)	60 (8.7)	32,000 (70,600)	52 (7.6)	32 400 (71,400)	46 (6.7)	32 800 (72,300)	42 (6.0)

All operating weights include a 90% fuel tank with 75 kg (165 lb) operator.

330 Hydraulic Excavator Specifications

Major Component Weights

	kg	lb
Base machine, 6700 kg (14,770 lb) counterweight, long undercarriage with boom cylinders	21 200	46,800
Base machine, 6700 kg (14,770 lb) counterweight, long narrow undercarriage with boom cylinders	21 180	48,900
Track Shoes:		
600 mm (24") Width, 11 mm (0.43") Thick, Triple Grouser Track Shoes	3620	8,000
600 mm (24") Width, 13 mm (0.51") Thick, HD Triple Grouser Track Shoes	3830	8,400
700 mm (28") Width, 13 mm (0.51") Thick, HD Triple Grouser Track Shoes	4200	9,300
800 mm (31") Width, 13 mm (0.51") Thick, Triple Grouser Track Shoes with Step Extension for ISO 2867:2011	4590	10,100
900 mm (35") Width, 13 mm (0.51") Thick, Triple Grouser Track Shoes with Step Extension for ISO 2867:2011	4980	11,000
Two Boom Cylinders	490	1,080
Weight of 90% Fuel Tank and 75 kg (165 lb) Operator	460	1,010
Counterweight:		
6700 kg (14,770 lb) Counterweight	6700	14,800
Undercarriage (without track shoes):		
Long Undercarriage	6700	14,800
Long Narrow Undercarriage	6580	14,500
Boom (including lines, pins, stick cylinder):		
Reach Boom 6.15 m (20'2")	2310	5,100
HD Reach Boom 6.15 m (20'2")	2420	5,300
Sticks (including lines, pins, bucket cylinder, bucket linkage):		
Reach Stick R3.2CB2 (10'6")	1470	3,200
Reach Stick R2.65CB2 (8'8")	1370	3,000
HD Reach Stick R3.2 m (10'6")	1610	3,500
Buckets (without linkage, with tips and side-cutters):		
1.76 m ³ (2.30 yd ³) HD, CB Linkage	1350	2,980
1.76 m ³ (2.30 yd ³) GD, CB Linkage	1090	2,400
Quick Couplers:		
Pin Grabber QC CB with Pins	530	1,200
Pin Grabber QC CB without Pins	500	1,100
Dedicated QC	430	900

330 Hydraulic Excavator Specifications

Dimensions

All dimensions are approximate and may vary depending on bucket selection.

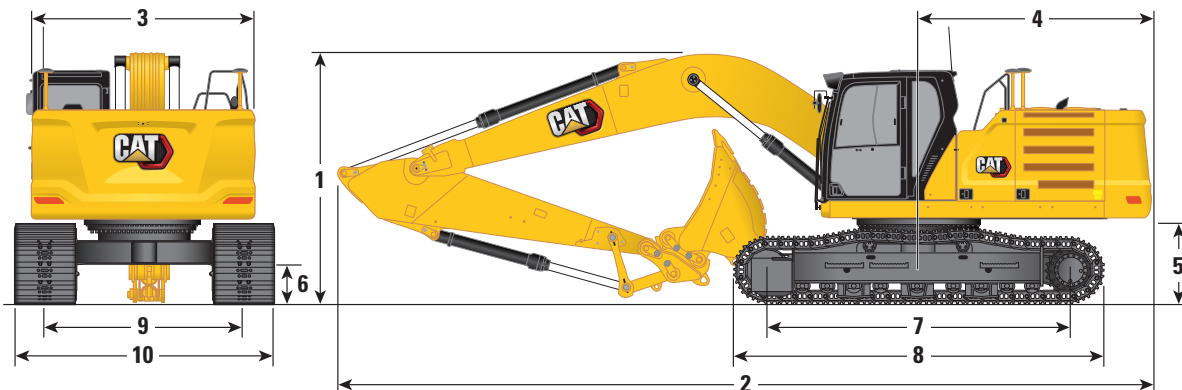

Undercarriage	Long Undercarriage			
	Reach Boom 6.15 m (20'2")			
	Reach Stick			
Boom Option	Reach Boom 6.15 m (20'2")			
Stick Options	R3.2CB2 (10'6")		R2.65CB2 (8'8")	
	1 Machine Height:			
Cab Height	3060 mm	10'0"	3060 mm	10'0"
FOGS Height	3200 mm	10'6"	3200 mm	10'6"
Handrails Height	3060 mm	10'0"	3060 mm	10'0"
With Boom/Stick/Bucket Installed	3400 mm	11'2"	3450 mm	11'4"
With Boom/Stick Installed	3380 mm	11'1"	3380 mm	11'1"
With Boom Installed	3060 mm	10'0"	3060 mm	10'0"
2 Machine Length:				
With Boom/Stick/Bucket Installed	10 420 mm	34'2"	10 420 mm	34'2"
With Boom/Stick Installed	10 420 mm	34'2"	10 420 mm	34'2"
With Boom Installed	9230 mm	30'3"	9230 mm	30'3"
3 Upperframe Width without Walkways	2940 mm	9'8"	2940 mm	9'8"
4 Tail Swing Radius	3130 mm	10'3"	3130 mm	10'3"
5 Counterweight Clearance	1120 mm	3'8"	1120 mm	3'8"
6 Ground Clearance	490 mm	1'7"	490 mm	1'7"
7 Length to Center of Rollers	3990 mm	13'1"	3990 mm	13'1"
8 Track Length	4860 mm	15'11"	4860 mm	15'11"
9 Track Gauge	2590 mm	8'6"	2590 mm	8'6"
10 Undercarriage Width				
600 mm (24") Shoes	3190 mm	10'6"	3190 mm	10'6"
700 mm (28") Shoes	3290 mm	10'10"	3290 mm	10'10"
800 mm (31") Shoes	3390 mm	11'1"	3390 mm	11'1"
900 mm (35") Shoes	3490 mm	11'5"	3490 mm	11'5"
Bucket Type	HD		HD	
Bucket Capacity	1.76 m ³	2.30 yd ³	1.76 m ³	2.30 yd ³
Bucket Tip Radius	1660 mm	5'5"	1660 mm	5'5"

330 Hydraulic Excavator Specifications

Dimensions

All dimensions are approximate and may vary depending on bucket selection.

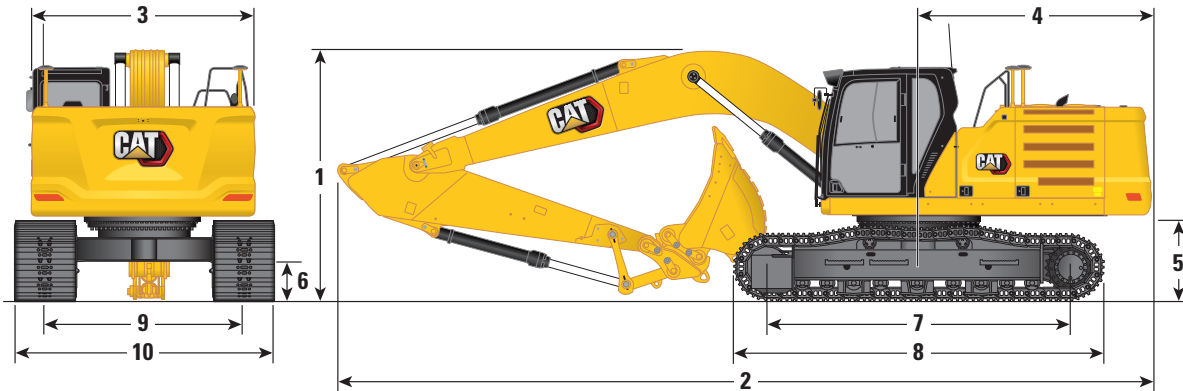

Undercarriage	Long Narrow Undercarriage			
	Reach Boom 6.15 m (20'2")			
	Reach Stick			
Boom Option	Reach Boom 6.15 m (20'2")			
Stick Options	R3.2CB2 (10'6")		R2.65CB2 (8'8")	
	1 Machine Height:			
Cab Height	3060 mm	10'0"	3060 mm	10'0"
FOGS Height	3200 mm	10'6"	3200 mm	10'6"
Handrails Height	3060 mm	10'0"	3060 mm	10'0"
With Boom/Stick/Bucket Installed	3400 mm	11'2"	3450 mm	11'4"
With Boom/Stick Installed	3280 mm	10'9"	3280 mm	10'9"
With Boom Installed	3060 mm	10'0"	3060 mm	10'0"
2 Machine Length:				
With Boom/Stick/Bucket Installed	10 420 mm	34'2"	10 420 mm	34'2"
With Boom/Stick Installed	10 420 mm	34'2"	10 420 mm	34'2"
With Boom Installed	9230 mm	30'3"	9230 mm	30'3"
3 Upperframe Width without Walkways	2940 mm	9'8"	2940 mm	9'8"
4 Tail Swing Radius	3130 mm	10'3"	3130 mm	10'3"
5 Counterweight Clearance	1120 mm	3'8"	1120 mm	3'8"
6 Ground Clearance	490 mm	1'7"	490 mm	1'7"
7 Length to Center of Rollers	3990 mm	13'1"	3990 mm	13'1"
8 Track Length	4860 mm	15'11"	4860 mm	15'11"
9 Track Gauge	2390 mm	7'10"	2390 mm	7'10"
10 Undercarriage Width				
600 mm (24") Shoes	2990 mm	9'9"	2990 mm	9'9"
700 mm (28") Shoes	3090 mm	10'1"	3090 mm	10'1"
800 mm (31") Shoes	3190 mm	10'6"	3190 mm	10'6"
900 mm (35") Shoes	3290 mm	10'10"	3290 mm	10'10"
Bucket Type	HD		HD	
Bucket Capacity	1.76 m ³	2.30 yd ³	1.76 m ³	2.30 yd ³
Bucket Tip Radius	1660 mm	5'5"	1660 mm	5'5"

330 Hydraulic Excavator Specifications

Working Ranges and Forces

All dimensions are approximate and may vary depending on bucket selection.

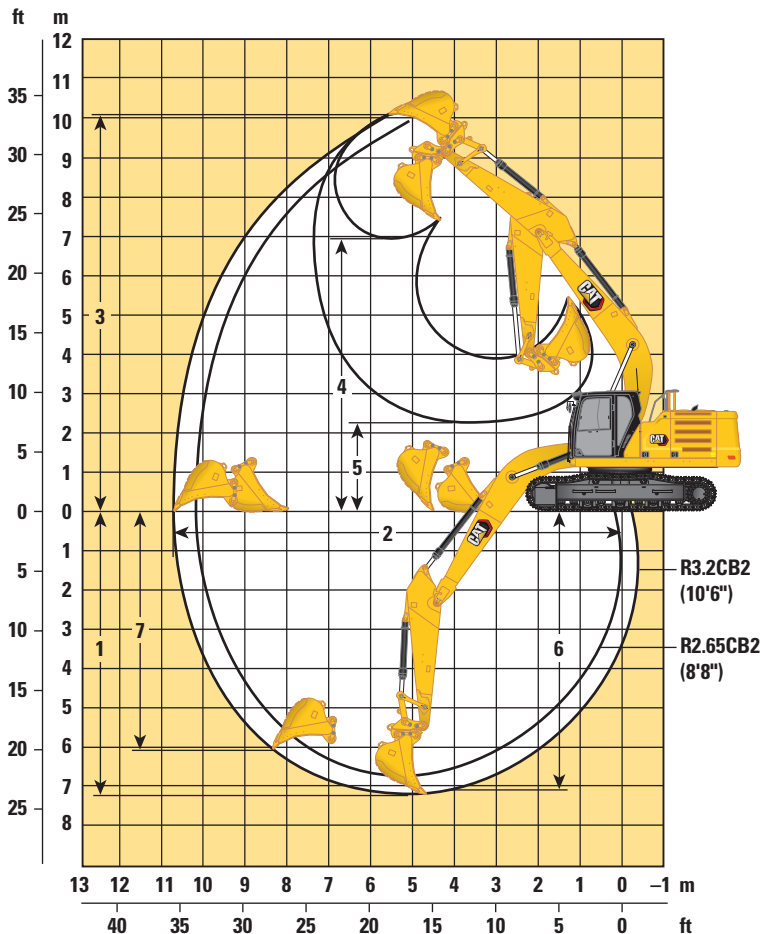

Undercarriages	Long Undercarriage/Long Narrow Undercarriage			
	Reach Boom 6.15 m (20'2")			
	Reach Stick			
Boom Options				
Stick Options	R3.2CB2 (10'6")		R2.65CB2 (8'8")	
1 Maximum Digging Depth	7240 mm	23'9"	6690 mm	21'11"
2 Maximum Reach at Ground Line	10 680 mm	35'0"	10 210 mm	33'6"
3 Maximum Cutting Height	10 030 mm	32'11"	9920 mm	32'7"
4 Maximum Loading Height	6950 mm	22'10"	6800 mm	22'4"
5 Minimum Loading Height	2300 mm	7'7"	2850 mm	9'4"
6 Maximum Depth Cut for 2440 mm (8'0") Level Bottom	7090 mm	23'3"	6520 mm	21'5"
7 Maximum Vertical Wall Digging Depth	6010 mm	19'9"	5700 mm	18'8"
Bucket Digging Force (ISO)*	179 kN	40,240 lbf	179 kN	40,240 lbf
Stick Digging Force (ISO)*	126 kN	28,330 lbf	145 kN	32,600 lbf
Bucket Type	HD		HD	
Bucket Capacity	1.76 m ³	2.30 yd ³	1.76 m ³	2.30 yd ³
Bucket Tip Radius	1660 mm	5'5"	1660 mm	5'5"

*8.5% Auto Dig Boost pressure not included.

330 Hydraulic Excavator Specifications

Reach Boom Lift Capacities – Counterweight: 6700 kg (14,770 lb) – without Bucket, Heavy Lift: On

Long Narrow Undercarriage

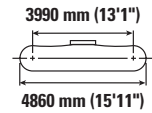
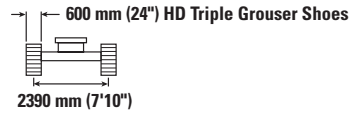
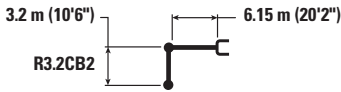

Reach Boom	Unit	1.5 m/5.0 ft		3.0 m/10.0 ft		4.5 m/15.0 ft		6.0 m/20.0 ft		7.5 m/25.0 ft		9.0 m/30.0 ft		mm in		
		kg	lb	kg	lb	kg	lb	kg	lb	kg	lb	kg	lb	kg	lb	
7.5 m 25.0 ft	kg lb													*5600 *12,350	*5600 *12,350	7280 290
6.0 m 20.0 ft	kg lb								*7900 *16,700	5800 12,450				*5350 *11,750	4950 11,050	8240 330
4.5 m 15.0 ft	kg lb							*9250 *20,050	7950 17,100	*8400 *18,300	5700 12,200			*5300 *11,650	4400 9,700	8830 350
3.0 m 10.0 ft	kg lb					*14 250 *30,650	11 450 24,650	*10 800 *23,400	7550 16,300	9100 19,550	5500 11,850	*6500 4200		*5450 *11,950	4100 9,000	9140 360
1.5 m 5.0 ft	kg lb					*17 000 *36,700	10 750 23,200	*12 300 *26,550	7250 15,600	8900 19,100	5300 11,450	6800 *13,650	4100 8,850	*5800 *12,700	4000 8,750	9190 370
0 m 0 ft	kg lb					*18 300 *39,550	10 400 22,450	12 200 26,250	7000 15,100	8750 18,800	5200 11,150			*6350 *14,000	4050 8,900	8990 360
-1.5 m -5.0 ft	kg lb	*6950 *15,550	*6950 *15,550	*10 950 *24,800	*10 950 *24,800	*18 250 *39,600	10 350 22,200	12 100 25,950	6900 14,850	8650 18,650	5100 11,050			7250 16,000	4350 9,550	8520 340
-3.0 m -10.0 ft	kg lb	*12 500 *28,000	*12 500 *28,000	*17 650 *40,050	*17 650 *40,050	*17 150 *37,100	10 400 22,350	12 100 26,000	6900 14,900	8700 18,750	5150 11,150			8350 18,500	4950 11,000	7730 310
-4.5 m -15.0 ft	kg lb			*19 900 *42,750	*19 900 *42,750	*14 600 *31,300	10 600 22,850	*10 800 *22,850	7100 15,300					*9500 *20,850	6400 14,300	6510 260

Reach Boom Lift Capacities – Counterweight: 6700 kg (14,770 lb) – without Bucket, Heavy Lift: On

Long Narrow Undercarriage

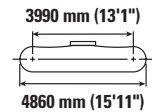
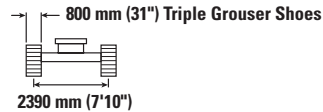
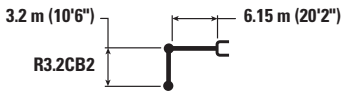

Reach Boom	Unit	1.5 m/5.0 ft		3.0 m/10.0 ft		4.5 m/15.0 ft		6.0 m/20.0 ft		7.5 m/25.0 ft		9.0 m/30.0 ft		mm in		
		kg	lb	kg	lb	kg	lb	kg	lb	kg	lb	kg	lb	kg	lb	
7.5 m 25.0 ft	kg lb													*5600 *12,350	*5600 *12,350	7280 290
6.0 m 20.0 ft	kg lb								*7900 *16,700	5950 12,750				*5350 *11,750	5100 11,350	8240 330
4.5 m 15.0 ft	kg lb							*9250 *20,050	8150 17,500	*8400 *18,300	5850 12,550			*5300 *11,650	4500 9,950	8830 350
3.0 m 10.0 ft	kg lb					*14 250 *30,650	11 700 25,250	*10 800 *23,400	7750 16,750	*9150 *19,900	5650 12,150	*6500 4300		*5450 *11,950	4200 9,250	9140 360
1.5 m 5.0 ft	kg lb					*17 000 *36,700	11 050 23,800	*12 300 *26,550	7450 16,000	9150 19,700	5450 11,750	7000 *13,650	4250 9,100	*5800 *12,700	4100 9,000	9190 370
0 m 0 ft	kg lb					*18 300 *39,550	10 700 23,050	12 550 27,000	7200 15,500	9000 19,350	5350 11,500			*6350 *14,000	4200 9,200	8990 360
-1.5 m -5.0 ft	kg lb	*6950 *15,550	*6950 *15,550	*10 950 *24,800	*10 950 *24,800	*18 250 *39,600	10 600 22,850	12 450 26,750	7100 15,250	8950 19,200	5250 11,350			*7350 *16,250	4450 9,850	8520 340
-3.0 m -10.0 ft	kg lb	*12 500 *28,000	*12 500 *28,000	*17 650 *40,050	*17 650 *40,050	*17 150 *37,100	10 700 23,000	12 450 26,800	7100 15,300	8950 19,350	5300 11,450			8600 19,050	5100 11,300	7730 310
-4.5 m -15.0 ft	kg lb			*19 900 *42,750	*19 900 *42,750	*14 600 *31,300	10 900 23,450	*10 800 *22,850	7300 15,700					*9500 *20,850	6550 14,700	6510 260



ISO 10567:2007



* Indicates that the load is limited by hydraulic lifting capacity rather than tipping load. The above loads are in compliance with hydraulic excavator lift capacity standard ISO 10567:2007. They do not exceed 87% of hydraulic lifting capacity or 75% of tipping load. Weight of all lifting accessories must be deducted from the above lifting capacities. Lifting capacities are based on the machine standing on a firm, uniform supporting surface. The use of a work tool attachment point to handle/lift objects, could affect the machine lift performance.

Lift capacity stays with ±5% for all available track shoes.

Always refer to the appropriate Operation and Maintenance Manual for specific product information.

330 Hydraulic Excavator Specifications

Reach Boom Lift Capacities – Counterweight: 6700 kg (14,770 lb) – without Bucket, Heavy Lift: On

Long Narrow Undercarriage

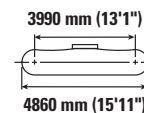
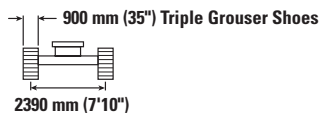
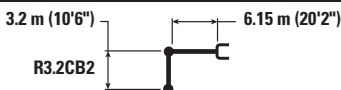

		1.5 m/5.0 ft		3.0 m/10.0 ft		4.5 m/15.0 ft		6.0 m/20.0 ft		7.5 m/25.0 ft		9.0 m/30.0 ft		mm in		
7.5 m 25.0 ft	kg lb													*5600 *12,350	*5600 *12,350	7280 290
6.0 m 20.0 ft	kg lb									*7900 *16,700	6000 12,900			*5350 *11,750	5150 11,450	8240 330
4.5 m 15.0 ft	kg lb							*9250 *20,050	8200 17,700	*8400 *18,300	5900 12,650			*5300 *11,650	4550 10,100	8830 350
3.0 m 10.0 ft	kg lb					*14 250 *30,650	11 850 25,500	*10 800 *23,400	7850 16,900	*9150 *19,900	5700 12,300	*6500 4350		*5450 *11,950	4250 9,400	9140 360
1.5 m 5.0 ft	kg lb					*17 000 *36,700	11 150 24,050	*12 300 *26,550	7500 16,200	9250 19,900	5550 11,900	7100 *13,650	4300 9,200	*5800 *12,700	4150 9,150	9190 370
0 m 0 ft	kg lb					*18 300 *39,550	10 850 23,300	12 700 27,300	7300 15,700	9100 19,600	5400 11,600			*6350 *14,000	4250 9,300	8990 360
-1.5 m -5.0 ft	kg lb	*6950 *15,550	*6950 *15,550	*10 950 *24,800	*10 950 *24,800	*18 250 *39,600	10 750 23,100	12 600 27,050	7150 15,450	9050 19,450	5350 11,500			*7350 *16,250	4550 9,950	8520 340
-3.0 m -10.0 ft	kg lb	*12 500 *28,000	*12 500 *28,000	*17 650 *40,050	*17 650 *40,050	*17 150 *37,100	10 800 23,250	12 600 27,100	7200 15,500	9100 19,550	5350 11,600			8700 19,300	5200 11,450	7730 310
-4.5 m -15.0 ft	kg lb			*19 900 *42,750	*19 900 *42,750	*14 600 *31,300	11 000 23,750	*10 800 *22,850	7350 15,900					*9500 *20,850	6650 14,850	6510 260

Reach Boom Lift Capacities – Counterweight: 6700 kg (14,770 lb) – without Bucket, Heavy Lift: On

Long Narrow Undercarriage

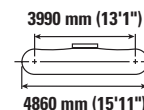
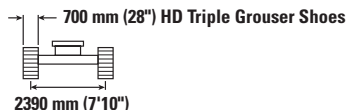
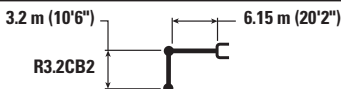

		1.5 m/5.0 ft		3.0 m/10.0 ft		4.5 m/15.0 ft		6.0 m/20.0 ft		7.5 m/25.0 ft		9.0 m/30.0 ft		mm in		
7.5 m 25.0 ft	kg lb													*5600 *12,350	*5600 *12,350	7280 290
6.0 m 20.0 ft	kg lb									*7900 *16,700	5900 12,650			*5350 *11,750	5050 11,200	8240 330
4.5 m 15.0 ft	kg lb							*9250 *20,050	8050 17,350	*8400 *18,300	5750 12,400			*5300 *11,650	4450 9,850	8830 350
3.0 m 10.0 ft	kg lb					*14 250 *30,650	11 600 25,000	*10 800 *23,400	7700 16,550	*9150 *19,900	5600 12,050	*6500 4250		*5450 *11,950	4150 9,150	9140 360
1.5 m 5.0 ft	kg lb					*17 000 *36,700	10 950 23,550	*12 300 *26,550	7350 15,850	9050 19,450	5400 11,650	6900 *13,650	4200 9,000	*5800 *12,700	4050 8,900	9190 370
0 m 0 ft	kg lb					*18 300 *39,550	10 600 22,800	12 400 26,700	7100 15,350	8900 19,150	5250 11,350			*6350 *14,000	4150 9,100	8990 360
-1.5 m -5.0 ft	kg lb	*6950 *15,550	*6950 *15,550	*10 950 *24,800	*10 950 *24,800	*18 250 *39,600	10 500 22,600	12 300 26,400	7000 15,100	8800 19,000	5200 11,200			*7350 *16,250	4400 9,750	8520 340
-3.0 m -10.0 ft	kg lb	*12 500 *28,000	*12 500 *28,000	*17 650 *40,050	*17 650 *40,050	*17 150 *37,100	10 550 22,750	12 300 26,500	7050 15,150	8850 19,100	5250 11,350			8500 18,850	5050 11,200	7730 310
-4.5 m -15.0 ft	kg lb			*19 900 *42,750	*19 900 *42,750	*14 600 *31,300	10 800 23,200	*10 800 *22,850	7200 15,550					*9500 *20,850	6500 14,550	6510 260



ISO 10567:2007



* Indicates that the load is limited by hydraulic lifting capacity rather than tipping load. The above loads are in compliance with hydraulic excavator lift capacity standard ISO 10567:2007. They do not exceed 87% of hydraulic lifting capacity or 75% of tipping load. Weight of all lifting accessories must be deducted from the above lifting capacities. Lifting capacities are based on the machine standing on a firm, uniform supporting surface. The use of a work tool attachment point to handle/lift objects, could affect the machine lift performance.

Lift capacity stays with ±5% for all available track shoes.

Always refer to the appropriate Operation and Maintenance Manual for specific product information.

330 Hydraulic Excavator Specifications

Reach Boom Lift Capacities – Counterweight: 6700 kg (14,770 lb) – without Bucket, Heavy Lift: On

Long Narrow Undercarriage

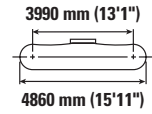
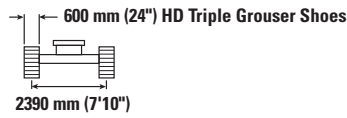
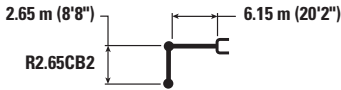

Reach Boom	Unit	3.0 m/10.0 ft		4.5 m/15.0 ft		6.0 m/20.0 ft		7.5 m/25.0 ft		mm in		
7.5 m 25.0 ft	kg lb					*19,100	17,600			*7300 *16,200	6900 15,550	6680 260
6.0 m 20.0 ft	kg lb					*8900 *19,450	8100 17,450	*8350 *15,800	5750 12,250	*6900 *15,200	5500 12,200	7710 310
4.5 m 15.0 ft	kg lb			*12 300 *26,400	12 000 25,900	*10 050 *21,750	7850 16,900	*8950 *19,600	5650 12,100	*6800 *14,950	4800 10,550	8340 330
3.0 m 10.0 ft	kg lb			*15 550 *33,350	11 200 24,200	*11 500 *24,850	7500 16,200	9050 19,500	5500 11,800	*6950 *15,350	4450 9,750	8670 340
1.5 m 5.0 ft	kg lb			*16 900 *38,500	10 650 22,950	12 450 26,750	7200 15,550	8900 19,150	5350 11,450	7150 15,700	4350 9,500	8720 350
0 m 0 ft	kg lb			*18 000 *40,100	10 450 22,500	12 200 26,250	7000 15,150	8750 18,850	5200 11,250	7350 16,150	4400 9,750	8510 340
-1.5 m -5.0 ft	kg lb	*10 650 *24,350	*10 650 *24,350	*18 000 *39,050	10 450 22,450	12 150 26,100	6950 15,000	8750 18,800	5200 11,200	8000 17,600	4800 10,550	8010 320
-3.0 m -10.0 ft	kg lb	*19 950 *45,500	*19 950 44,000	*16 400 *35,500	10 550 22,700	12 250 26,300	7050 15,150			9450 20,900	5600 12,400	7170 280
-4.5 m -15.0 ft	kg lb			*13 100 *27,950	10 800 23,350					*9550 *20,950	7600 17,100	5820 230

Reach Boom Lift Capacities – Counterweight: 6700 kg (14,770 lb) – without Bucket, Heavy Lift: On

Long Narrow Undercarriage

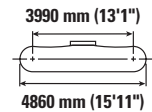
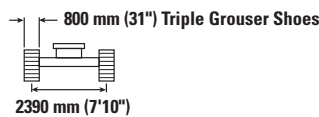
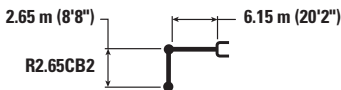

Reach Boom	Unit	3.0 m/10.0 ft		4.5 m/15.0 ft		6.0 m/20.0 ft		7.5 m/25.0 ft		mm in		
7.5 m 25.0 ft	kg lb					*19,100	18,050			*7300 *16,200	7050 15,950	6680 260
6.0 m 20.0 ft	kg lb					*8900 *19,450	8300 17,900	*8350 *15,800	5900 12,600	*6900 *15,200	5600 12,500	7710 310
4.5 m 15.0 ft	kg lb			*12 300 *26,400	*12 300 *26,400	*10 050 *21,750	8050 17,350	*8950 *19,600	5800 12,450	*6800 *14,950	4900 10,850	8340 330
3.0 m 10.0 ft	kg lb			*15 550 *33,350	11 500 24,850	*11 500 *24,850	7700 16,600	9350 20,050	5650 12,100	*6950 *15,350	4550 10,050	8670 340
1.5 m 5.0 ft	kg lb			*16 900 *38,500	10 950 23,600	12 800 27,500	7400 15,950	9150 19,700	5500 11,800	7350 16,150	4450 9,800	8720 350
0 m 0 ft	kg lb			*18 000 *40,100	10 750 23,100	12 600 27,050	7200 15,550	9050 19,450	5350 11,550	7550 16,650	4550 10,000	8510 340
-1.5 m -5.0 ft	kg lb	*10 650 *24,350	*10 650 *24,350	*18 000 *39,050	10 700 23,050	12 500 26,900	7150 15,450	9000 19,400	5350 11,500	8200 18,150	4900 10,850	8010 320
-3.0 m -10.0 ft	kg lb	*19 950 *45,500	*19 950 45,150	*16 400 *35,500	10 850 23,300	*12 450 *26,850	7200 15,550			9700 21,550	5750 12,750	7170 280
-4.5 m -15.0 ft	kg lb			*13 100 *27,950	11 100 23,950					*9550 *20,950	7800 17,550	5820 230



ISO 10567:2007



* Indicates that the load is limited by hydraulic lifting capacity rather than tipping load. The above loads are in compliance with hydraulic excavator lift capacity standard ISO 10567:2007. They do not exceed 87% of hydraulic lifting capacity or 75% of tipping load. Weight of all lifting accessories must be deducted from the above lifting capacities. Lifting capacities are based on the machine standing on a firm, uniform supporting surface. The use of a work tool attachment point to handle/lift objects, could affect the machine lift performance.

Lift capacity stays with ±5% for all available track shoes.

Always refer to the appropriate Operation and Maintenance Manual for specific product information.

330 Hydraulic Excavator Specifications

Reach Boom Lift Capacities – Counterweight: 6700 kg (14,770 lb) – without Bucket, Heavy Lift: On

Long Narrow Undercarriage

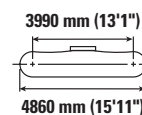
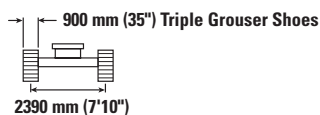
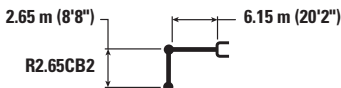

		3.0 m/10.0 ft		4.5 m/15.0 ft		6.0 m/20.0 ft		7.5 m/25.0 ft		mm in		
7.5 m 25.0 ft	kg lb					*19,100	18,200			*7300 *16,200	7150 16,100	6680 260
6.0 m 20.0 ft	kg lb					*8900 *19,450	8400 18,050	*8350 *15,800	5950 12,700	*6900 *15,200	5700 12,650	7710 310
4.5 m 15.0 ft	kg lb			*12 300 *26,400	*12 300 *26,400	*10 050 *21,750	8100 17,500	*8950 *19,600	5850 12,600	*6800 *14,950	4950 10,950	8340 330
3.0 m 10.0 ft	kg lb			*15 550 *33,350	11 650 25,100	*11 500 *24,850	7800 16,800	9450 20,300	5700 12,250	*6950 *15,350	4600 10,150	8670 340
1.5 m 5.0 ft	kg lb			*16 900 *38,500	10 850 23,850	*12 800 *27,700	7500 16,150	9250 19,900	5550 11,900	*7400 *16,250	4500 9,900	8720 350
0 m 0 ft	kg lb			*18 000 *40,100	10 850 23,350	12 750 27,350	7300 15,750	9150 19,650	5450 11,700	7650 16,850	4600 10,150	8510 340
-1.5 m -5.0 ft	kg lb	*10 650 *24,350	*10 650 *24,350	*18 000 *39,050	10 850 23,300	12 650 27,200	7250 15,600	9100 19,600	5400 11,650	8300 18,350	5000 10,950	8010 320
-3.0 m -10.0 ft	kg lb	*19 950 *45,500	*19 950 *45,500	*16 400 *35,550	10 950 23,550	*12 450 *26,850	7300 15,750			*9800 *21,600	5800 12,900	7170 280
-4.5 m -15.0 ft	kg lb			*13 100 *27,950	11 250 24,200					*9550 *20,950	7900 17,750	5820 230

Reach Boom Lift Capacities – Counterweight: 6700 kg (14,770 lb) – without Bucket, Heavy Lift: On

Long Narrow Undercarriage

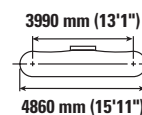
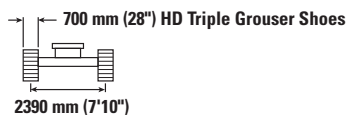
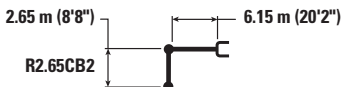

		3.0 m/10.0 ft		4.5 m/15.0 ft		6.0 m/20.0 ft		7.5 m/25.0 ft		mm in		
7.5 m 25.0 ft	kg lb					*19,100	17,850			*7300 *16,200	*7000 15,800	6680 260
6.0 m 20.0 ft	kg lb					*8900 *19,450	8250 17,700	*8350 *15,800	5800 12,450	*6900 *15,200	5550 12,350	7710 310
4.5 m 15.0 ft	kg lb			*12 300 *26,400	12 200 26,250	*10 050 *21,750	7950 17,150	*8950 *19,600	5750 12,300	*6800 *14,950	4850 10,750	8340 330
3.0 m 10.0 ft	kg lb			*15 550 *33,350	11 400 24,600	*11 500 *24,850	7600 16,450	9200 19,850	5550 12,000	*6950 *15,350	4500 9,950	8670 340
1.5 m 5.0 ft	kg lb			*16 900 *38,500	10 850 23,350	*12 800 *27,200	7350 15,800	9050 19,450	5400 11,650	7250 16,000	4400 9,650	8720 350
0 m 0 ft	kg lb			*18 000 *40,100	10 600 22,850	12 450 26,750	7150 15,400	8950 19,200	5300 11,450	7450 16,450	4500 9,900	8510 340
-1.5 m -5.0 ft	kg lb	*10 650 *24,350	*10 650 *24,350	*18 000 *39,050	10 600 22,800	12 350 26,600	7100 15,250	8900 19,150	5300 11,400	8150 17,900	4850 10,700	8010 320
-3.0 m -10.0 ft	kg lb	*19 950 *45,500	*19 950 44,650	*16 400 *35,550	10 700 23,050	12 450 26,750	7150 15,400			9600 21,300	5700 12,600	7170 280
-4.5 m -15.0 ft	kg lb			*13 100 *27,950	11 000 23,700					*9550 *20,950	7700 17,350	5820 230



ISO 10567:2007



* Indicates that the load is limited by hydraulic lifting capacity rather than tipping load. The above loads are in compliance with hydraulic excavator lift capacity standard ISO 10567:2007. They do not exceed 87% of hydraulic lifting capacity or 75% of tipping load. Weight of all lifting accessories must be deducted from the above lifting capacities. Lifting capacities are based on the machine standing on a firm, uniform supporting surface. The use of a work tool attachment point to handle/lift objects, could affect the machine lift performance.

Lift capacity stays with ±5% for all available track shoes.

Always refer to the appropriate Operation and Maintenance Manual for specific product information.

330 Hydraulic Excavator Specifications

Reach Boom Lift Capacities – Counterweight: 6700 kg (14,770 lb) – without Bucket, Heavy Lift: On

Long Undercarriage

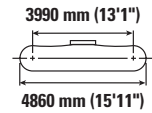
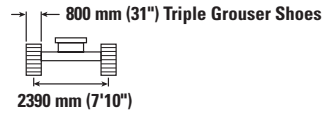
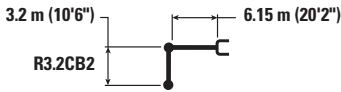

Reach Boom	Unit	1.5 m/5.0 ft		3.0 m/10.0 ft		4.5 m/15.0 ft		6.0 m/20.0 ft		7.5 m/25.0 ft		9.0 m/30.0 ft		mm in		
		kg	lb	kg	lb	kg	lb	kg	lb	kg	lb	kg	lb	kg	lb	
7.5 m 25.0 ft	kg lb													*5600 *12,350	*5600 *12,350	7280 290
6.0 m 20.0 ft	kg lb								*7900 *16,700	6450 13,800				*5350 *11,750	*5350 *11,750	8240 330
4.5 m 15.0 ft	kg lb							*9250 *20,050	8800 19,000	*8400 *18,300	6300 13,550			*5300 *11,650	4900 10,800	8830 350
3.0 m 10.0 ft	kg lb					*14 250 *30,650	12 850 27,700	*10 800 *23,400	8450 18,200	*9150 *19,900	6150 13,200	*6500 4700		*5450 *11,950	4550 10,050	9140 360
1.5 m 5.0 ft	kg lb					*17 000 *36,700	12 150 26,150	*12 300 *26,550	8100 17,450	9200 19,750	5950 12,800	7050 *13,650	4600 9,850	*5800 *12,700	4450 9,800	9190 370
0 m 0 ft	kg lb					*18 300 *39,550	11 800 25,400	12 600 27,100	7850 16,950	9050 19,450	5800 12,500			*6350 *14,000	4550 10,000	8990 360
-1.5 m -5.0 ft	kg lb	*6950 *15,550	*6950 *15,550	*10 950 *24,800	*10 950 *24,800	*18 250 *39,600	11 700 25,200	12 500 26,850	7750 16,700	8950 19,300	5750 12,350			*7350 *16,250	4850 10,700	8520 340
-3.0 m -10.0 ft	kg lb	*12 500 *28,000	*12 500 *28,000	*17 650 *40,050	*17 650 *40,050	*17 150 *37,100	11 800 25,350	12 500 26,900	7750 16,750	9000 19,400	5800 12,500			8650 19,150	5550 12,300	7730 310
-4.5 m -15.0 ft	kg lb			*19 900 *42,750	*19 900 *42,750	*14 600 *31,300	12 000 25,850	*10 800 *22,850	7950 17,150					*9500 *20,850	7150 16,000	6510 260

Reach Boom Lift Capacities – Counterweight: 6700 kg (14,770 lb) – without Bucket, Heavy Lift: On

Long Undercarriage

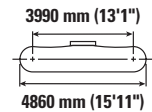
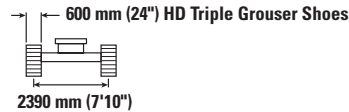
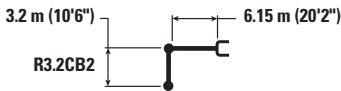

Reach Boom	Unit	1.5 m/5.0 ft		3.0 m/10.0 ft		4.5 m/15.0 ft		6.0 m/20.0 ft		7.5 m/25.0 ft		9.0 m/30.0 ft		mm in		
		kg	lb	kg	lb	kg	lb	kg	lb	kg	lb	kg	lb	kg	lb	
7.5 m 25.0 ft	kg lb													*5600 *12,350	*5600 *12,350	7280 290
6.0 m 20.0 ft	kg lb								*7900 *16,700	6250 13,450				*5350 *11,750	*5350 *11,750	8240 330
4.5 m 15.0 ft	kg lb							*9250 *20,050	8600 18,500	*8400 *18,300	*6150 13,200			*5300 *11,650	4750 10,500	8830 350
3.0 m 10.0 ft	kg lb					*14 250 *30,650	12 850 27,700	*10 800 *23,400	8250 17,750	9150 19,650	5950 12,850	*6500 4550		*5450 *11,950	4450 9,750	9140 360
1.5 m 5.0 ft	kg lb					*17 000 *36,700	12 150 26,150	*12 300 *26,550	7900 17,000	8950 19,200	5800 12,450	6800 *13,650	4450 9,600	*5800 *12,700	4350 9,500	9190 370
0 m 0 ft	kg lb					*18 300 *39,550	11 800 25,400	12 600 27,100	7650 16,450	8800 18,900	5650 12,150			*6350 *14,000	4400 9,700	8990 360
-1.5 m -5.0 ft	kg lb	*6950 *15,550	*6950 *15,550	*10 950 *24,800	*10 950 *24,800	*18 250 *39,600	11 700 25,200	12 500 26,850	7550 16,250	8700 18,750	5600 12,000			7300 16,050	4750 10,400	8520 340
-3.0 m -10.0 ft	kg lb	*12 500 *28,000	*12 500 *28,000	*17 650 *40,050	*17 650 *40,050	*17 150 *37,100	11 800 25,350	12 500 26,900	7550 16,250	8750 18,850	5600 12,100			8400 18,600	5400 11,950	7730 310
-4.5 m -15.0 ft	kg lb			*19 900 *42,750	*19 900 *42,750	*14 600 *31,300	12 000 25,850	*10 800 *22,850	7750 16,700					*9500 *20,850	6950 15,550	6510 260



ISO 10567:2007



* Indicates that the load is limited by hydraulic lifting capacity rather than tipping load. The above loads are in compliance with hydraulic excavator lift capacity standard ISO 10567:2007. They do not exceed 87% of hydraulic lifting capacity or 75% of tipping load. Weight of all lifting accessories must be deducted from the above lifting capacities. Lifting capacities are based on the machine standing on a firm, uniform supporting surface. The use of a work tool attachment point to handle/lift objects, could affect the machine lift performance.

Lift capacity stays with ±5% for all available track shoes.

Always refer to the appropriate Operation and Maintenance Manual for specific product information.

330 Hydraulic Excavator Specifications

Reach Boom Lift Capacities – Counterweight: 6700 kg (14,770 lb) – without Bucket, Heavy Lift: On

Long Undercarriage

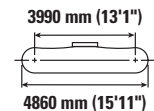
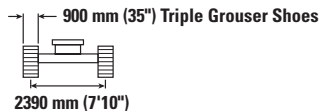
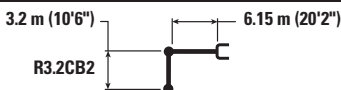

Reach Boom	Unit	1.5 m/5.0 ft		3.0 m/10.0 ft		4.5 m/15.0 ft		6.0 m/20.0 ft		7.5 m/25.0 ft		9.0 m/30.0 ft		mm in		
		kg	lb	kg	lb	kg	lb	kg	lb	kg	lb	kg	lb	kg	lb	mm
7.5 m 25.0 ft	kg lb													*5600 *12,350	*5600 *12,350	7280 290
6.0 m 20.0 ft	kg lb								*7900 *16,700	6350 13,950				*5350 *11,750	*5350 *11,750	8240 330
4.5 m 15.0 ft	kg lb							*9250 *20,050	8900 19,200	*8400 *18,300	6350 13,700			*5300 *11,650	4950 10,900	8830 350
3.0 m 10.0 ft	kg lb					*14 250 *30,650	13 000 27,950	*10 800 *23,400	8550 18,400	*9150 *19,900	6200 13,350	*6500 4750		*5450 *11,950	4600 10,150	9140 360
1.5 m 5.0 ft	kg lb					*17 000 *36,700	12 300 26,450	*12 300 *26,550	8200 17,650	9300 20,000	6000 12,950	7100 *13,650	4650 10,000	*5800 *12,700	4500 9,900	9190 370
0 m 0 ft	kg lb					*18 300 *39,550	11 950 25,700	12 750 27,450	7950 17,100	9150 19,650	5850 12,650			*6350 *14,000	4600 10,100	8990 360
-1.5 m -5.0 ft	kg lb	*6950 *15,550	*6950 *15,550	*10 950 *24,800	*10 950 *24,800	*18 250 *39,600	11 850 25,450	12 650 27,150	7850 16,900	9050 19,500	5800 12,500			*7350 *16,250	4900 10,850	8520 340
-3.0 m -10.0 ft	kg lb	*12 500 *28,000	*12 500 *28,000	*17 650 *40,050	*17 650 *40,050	*17 150 *37,100	11 900 25,600	12 650 27,200	7850 16,950	9100 19,650	5850 12,600			8750 19,350	5650 12,450	7730 310
-4.5 m -15.0 ft	kg lb			*19 900 *42,750	*19 900 *42,750	*14 600 *31,300	12 150 26,100	*10 800 *22,850	8050 17,350					*9500 *20,850	7250 16,200	6510 260

Reach Boom Lift Capacities – Counterweight: 6700 kg (14,770 lb) – without Bucket, Heavy Lift: On

Long Undercarriage

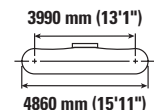
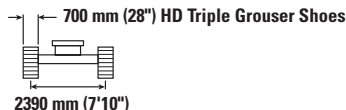
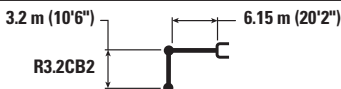

Reach Boom	Unit	1.5 m/5.0 ft		3.0 m/10.0 ft		4.5 m/15.0 ft		6.0 m/20.0 ft		7.5 m/25.0 ft		9.0 m/30.0 ft		mm in		
		kg	lb	kg	lb	kg	lb	kg	lb	kg	lb	kg	lb	kg	lb	mm
7.5 m 25.0 ft	kg lb													*5600 *12,350	*5600 *12,350	7280 290
6.0 m 20.0 ft	kg lb								*7900 *16,700	6350 13,650				*5350 *11,750	*5350 *11,750	8240 330
4.5 m 15.0 ft	kg lb							*9250 *20,050	8750 18,800	*8400 *18,300	6250 13,400			*5300 *11,650	4850 10,700	8830 350
3.0 m 10.0 ft	kg lb					*14 250 *30,650	12 700 27,400	*10 800 *23,400	8350 18,000	*9150 *19,900	6050 13,050	*6500 4600		*5450 *11,950	4500 9,950	9140 360
1.5 m 5.0 ft	kg lb					*17 000 *36,700	12 000 25,900	*12 300 *26,550	8000 17,250	9100 19,550	5900 12,650	6950 *13,650	4550 9,750	*5800 *12,700	4400 9,700	9190 370
0 m 0 ft	kg lb					*18 300 *39,550	11 700 25,100	12 450 26,800	7750 16,750	8950 19,200	5750 12,350			*6350 *14,000	4500 9,850	8990 360
-1.5 m -5.0 ft	kg lb	*6950 *15,550	*6950 *15,550	*10 950 *24,800	*10 950 *24,800	*18 250 *39,600	11 600 24,900	12 350 26,550	7650 16,500	8850 19,050	5650 12,200			*7350 *16,250	4800 10,600	8520 340
-3.0 m -10.0 ft	kg lb	*12 500 *28,000	*12 500 *28,000	*17 650 *40,050	*17 650 *40,050	*17 150 *37,100	11 650 25,050	12 350 26,600	7700 16,550	8900 19,200	5700 12,350			8550 18,900	5500 12,200	7730 310
-4.5 m -15.0 ft	kg lb			*19 900 *42,750	*19 900 *42,750	*14 600 *31,300	11 850 25,550	*10 800 *22,850	7850 16,950					*9500 *20,850	7050 15,850	6510 260



ISO 10567:2007



* Indicates that the load is limited by hydraulic lifting capacity rather than tipping load. The above loads are in compliance with hydraulic excavator lift capacity standard ISO 10567:2007. They do not exceed 87% of hydraulic lifting capacity or 75% of tipping load. Weight of all lifting accessories must be deducted from the above lifting capacities. Lifting capacities are based on the machine standing on a firm, uniform supporting surface. The use of a work tool attachment point to handle/lift objects, could affect the machine lift performance.

Lift capacity stays with ±5% for all available track shoes.

Always refer to the appropriate Operation and Maintenance Manual for specific product information.

330 Hydraulic Excavator Specifications

Reach Boom Lift Capacities – Counterweight: 6700 kg (14,770 lb) – without Bucket, Heavy Lift: On

Long Undercarriage

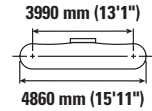
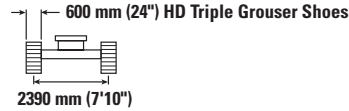
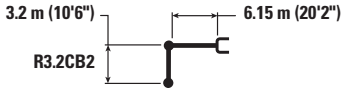

		1.5 m/5.0 ft		3.0 m/10.0 ft		4.5 m/15.0 ft		6.0 m/20.0 ft		7.5 m/25.0 ft		9.0 m/30.0 ft		mm in		
7.5 m 25.0 ft	kg lb													*5600 *12,350	*5600 *12,350	7280 290
6.0 m 20.0 ft	kg lb									*7900 *16,700	6300 13,550			*5350 *11,750	*5350 *11,750	8240 330
4.5 m 15.0 ft	kg lb							*9250 *20,050	8650 18,600	*8400 *18,300	6200 13,300			*5300 *11,650	4800 10,550	8830 350
3.0 m 10.0 ft	kg lb					*14 250 *30,650	12 600 27,150	*10 800 *23,400	8300 17,850	*9150 19,750	6000 12,900	*6500 4550	4550	*5450 *11,950	4450 9,850	9140 360
1.5 m 5.0 ft	kg lb					*17 000 *36,700	11 900 25,650	*12 300 *26,550	7950 17,100	9000 19,350	5800 12,500	6850 *13,650	4500 9,650	*5800 *12,700	4350 9,600	9190 370
0 m 0 ft	kg lb					*18 300 *39,550	11 550 24,850	12 350 26,500	7700 16,550	8850 19,000	5700 12,200			*6350 *14,000	4450 9,750	8990 360
-1.5 m -5.0 ft	kg lb	*6950 *15,550	*6950 *15,550	*10 950 *24,800	*10 950 *24,800	*18 250 *39,600	11 450 24,650	12 200 26,250	7600 16,350	8750 18,850	5600 12,100			7350 16,150	4750 10,450	8520 340
-3.0 m -10.0 ft	kg lb	*12 500 *28,000	*12 500 *28,000	*17 650 *40,050	*17 650 *40,050	*17 150 *37,100	11 550 24,800	12 250 26,300	7600 16,400	8800 19,000	5650 12,200			8450 18,700	5450 12,050	7730 310
-4.5 m -15.0 ft	kg lb			*19 900 *42,750	*19 900 *42,750	*14 600 *31,300	11 750 25,300	*10 800 *22,850	7750 16,800					*9500 *20,850	7000 15,650	6510 260



ISO 10567:2007



* Indicates that the load is limited by hydraulic lifting capacity rather than tipping load. The above loads are in compliance with hydraulic excavator lift capacity standard ISO 10567:2007. They do not exceed 87% of hydraulic lifting capacity or 75% of tipping load. Weight of all lifting accessories must be deducted from the above lifting capacities. Lifting capacities are based on the machine standing on a firm, uniform supporting surface. The use of a work tool attachment point to handle/lift objects, could affect the machine lift performance.

Lift capacity stays with ±5% for all available track shoes.









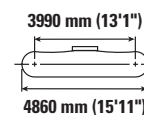
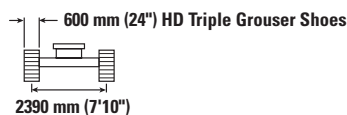

Always refer to the appropriate Operation and Maintenance Manual for specific product information.

330 Hydraulic Excavator Specifications

Reach Boom Lift Capacities – Counterweight: 6700 kg (14,770 lb) – without Bucket, Heavy Lift: On

Long Undercarriage









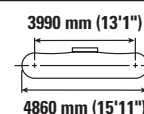
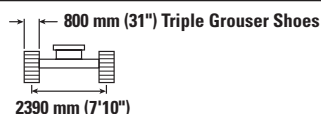
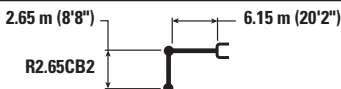

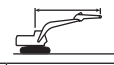

		3.0 m/10.0 ft		4.5 m/15.0 ft		6.0 m/20.0 ft		7.5 m/25.0 ft				mm in
												
7.5 m 25.0 ft	kg lb					*19,100	19,050			*7300 *16,200	*7300 *16,200	6680 260
6.0 m 20.0 ft	kg lb					*8900 *19,450	8800 18,900	*8350 *15,800	6200 13,250	*6900 *15,200	5900 13,150	7710 310
4.5 m 15.0 ft	kg lb			*12 300 *26,400	*12 300 *26,400	*10 050 *21,750	8500 18,300	*8950 *19,600	6100 13,100	*6800 *14,950	5200 11,450	8340 330
3.0 m 10.0 ft	kg lb			*15 550 *33,350	12 300 26,550	*11 500 *24,850	8150 17,600	9100 19,600	5950 12,800	*6950 *15,350	4800 10,600	8670 340
1.5 m 5.0 ft	kg lb			*16 900 *38,500	11 750 25,250	12 500 26,850	7850 16,900	8950 19,200	5800 12,450	7150 15,750	4700 10,300	8720 350
0 m 0 ft	kg lb			*18 000 *40,100	11 500 24,750	12 250 26,400	7650 16,500	8800 18,950	5700 12,200	7350 16,200	4800 10,550	8510 340
-1.5 m -5.0 ft	kg lb	*10 650 *24,350	*10 650 *24,350	*18 000 *39,050	11 500 24,700	12 200 26,250	7600 16,400	8800 18,900	5650 12,200	8000 17,700	5200 11,450	8010 320
-3.0 m -10.0 ft	kg lb	*19 950 *45,500	*19 950 *45,500	*16 400 *35,550	11 600 25,000	12 300 26,400	7650 16,550			9450 21,000	6100 13,500	7170 280
-4.5 m -15.0 ft	kg lb			*13 100 *27,950	11 900 25,650					*9550 *20,950	8300 18,600	5820 230

Reach Boom Lift Capacities – Counterweight: 6700 kg (14,770 lb) – without Bucket, Heavy Lift: On

Long Undercarriage



		3.0 m/10.0 ft		4.5 m/15.0 ft		6.0 m/20.0 ft		7.5 m/25.0 ft				mm in
												
7.5 m 25.0 ft	kg lb					*19,100	*19,100			*7300 *16,200	*7300 *16,200	6680 260
6.0 m 20.0 ft	kg lb					*8900 *19,450	*8900 19,350	*8350 *15,800	6350 13,600	*6900 *15,200	6100 13,500	7710 310
4.5 m 15.0 ft	kg lb			*12 300 *26,400	*12 300 *26,400	*10 050 *21,750	8700 18,800	*8950 *19,600	6250 13,450	*6800 *14,950	5300 11,750	8340 330
3.0 m 10.0 ft	kg lb			*15 550 *33,350	12 650 27,250	*11 500 *24,850	8400 18,050	9350 20,150	6100 13,150	*6950 *15,350	4950 10,900	8670 340
1.5 m 5.0 ft	kg lb			*16 900 *38,500	12 050 25,950	*12 800 27,600	8050 17,400	9200 19,750	5950 12,800	7400 16,250	4850 10,600	8720 350
0 m 0 ft	kg lb			*18 000 *40,100	11 850 25,450	12 650 27,150	7900 17,000	9050 19,500	5850 12,600	7600 16,700	4950 10,850	8510 340
-1.5 m -5.0 ft	kg lb	*10 650 *24,350	*10 650 *24,350	*18 000 *39,050	11 800 25,400	12 550 27,000	7800 16,850	9050 19,450	5800 12,550	8250 18,200	5350 11,800	8010 320
-3.0 m -10.0 ft	kg lb	*19 950 *45,500	*19 950 *45,500	*16 400 *35,550	11 950 25,650	*12 450 *26,850	7900 17,000			9750 *21,600	6250 13,900	7170 280
-4.5 m -15.0 ft	kg lb			*13 100 *27,950	12 200 26,300					*9550 *20,950	8500 19,150	5820 230



ISO 10567:2007



* Indicates that the load is limited by hydraulic lifting capacity rather than tipping load. The above loads are in compliance with hydraulic excavator lift capacity standard ISO 10567:2007. They do not exceed 87% of hydraulic lifting capacity or 75% of tipping load. Weight of all lifting accessories must be deducted from the above lifting capacities. Lifting capacities are based on the machine standing on a firm, uniform supporting surface. The use of a work tool attachment point to handle/lift objects, could affect the machine lift performance.

Lift capacity stays with ±5% for all available track shoes.

Always refer to the appropriate Operation and Maintenance Manual for specific product information.

330 Hydraulic Excavator Specifications

Reach Boom Lift Capacities – Counterweight: 6700 kg (14,770 lb) – without Bucket, Heavy Lift: On

Long Undercarriage

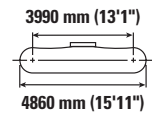
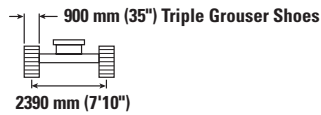
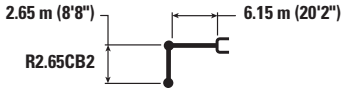

Reach	Unit	3.0 m/10.0 ft		4.5 m/15.0 ft		6.0 m/20.0 ft		7.5 m/25.0 ft		mm in		
		kg lb	kg lb	kg lb	kg lb	kg lb	kg lb	kg lb	kg lb	kg lb	kg lb	
7.5 m 25.0 ft	kg lb					*19,100 *19,100				*7300 *16,200	*7300 *16,200	6680 260
6.0 m 20.0 ft	kg lb					*8900 *19,450	*8900 *19,450	*8350 *15,800	6400 13,750	*6900 *15,200	6150 13,650	7710 310
4.5 m 15.0 ft	kg lb			*12 300 *26,400	*12 300 *26,400	*10 050 *21,750	8800 19,000	*8950 *19,600	6350 13,600	*6800 *14,950	5400 11,900	8340 330
3.0 m 10.0 ft	kg lb			*15 550 *33,350	12 750 27,500	*11 500 *24,850	8450 18,250	9450 20,350	6150 13,300	*6950 *15,350	5000 11,000	8670 340
1.5 m 5.0 ft	kg lb			*16 900 *38,500	12 200 26,250	*12 800 *27,700	8150 17,600	9300 20,000	6000 12,950	*7400 *16,250	4900 10,750	8720 350
0 m 0 ft	kg lb			*18 000 *40,100	11 950 25,750	12 800 27,450	7950 17,150	9200 19,750	5900 12,700	7700 16,900	5000 11,000	8510 340
-1.5 m -5.0 ft	kg lb	*10 650 *24,350	*10 650 *24,350	*18 000 *39,050	11 950 25,700	12 700 27,300	7900 17,050	9150 19,700	5900 12,650	8350 18,400	5400 11,950	8010 320
-3.0 m -10.0 ft	kg lb	*19 950 *45,500	*19 950 *45,500	*16 400 *35,550	12 050 25,950	*12 450 *26,850	8000 17,200			*9800 *21,600	6350 14,050	7170 280
-4.5 m -15.0 ft	kg lb			*13 100 *27,950	12 350 26,600					*9550 *20,950	8600 19,350	5820 230

Reach Boom Lift Capacities – Counterweight: 6700 kg (14,770 lb) – without Bucket, Heavy Lift: On

Long Undercarriage

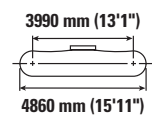
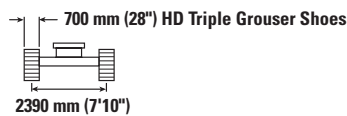

Reach	Unit	3.0 m/10.0 ft		4.5 m/15.0 ft		6.0 m/20.0 ft		7.5 m/25.0 ft		mm in		
		kg lb	kg lb	kg lb	kg lb	kg lb	kg lb	kg lb	kg lb	kg lb	kg lb	
7.5 m 25.0 ft	kg lb					*19,100 *19,100				*7300 *16,200	*7300 *16,200	6680 260
6.0 m 20.0 ft	kg lb					*8900 *19,450	8900 19,150	*8350 *15,800	6300 13,450	*6900 *15,200	6000 13,400	7710 310
4.5 m 15.0 ft	kg lb			*12 300 *26,400	*12 300 *26,400	*10 050 *21,750	8650 18,600	*8950 *19,600	6200 13,350	*6800 *14,950	5250 11,650	8340 330
3.0 m 10.0 ft	kg lb			*15 550 *33,350	12 500 26,950	*11 500 *24,850	8300 17,850	9250 19,900	6050 13,000	*6950 *15,350	4900 10,750	8670 340
1.5 m 5.0 ft	kg lb			*16 900 *38,500	11 900 25,700	12 700 27,300	8000 17,200	9100 19,550	5900 12,650	7300 16,050	4750 10,500	8720 350
0 m 0 ft	kg lb			*18 000 *40,100	11 700 25,200	12 500 26,850	7800 16,800	8950 19,300	5750 12,450	7500 16,500	4900 10,750	8510 340
-1.5 m -5.0 ft	kg lb	*10 650 *24,350	*10 650 *24,350	*18 000 *39,050	11 700 25,150	12 400 26,700	7750 16,650	8950 19,250	5750 12,400	8150 18,000	5300 11,650	8010 320
-3.0 m -10.0 ft	kg lb	*19 950 *45,500	*19 950 *45,500	*16 400 *35,550	11 800 25,400	*12 450 *26,850	7800 16,800			9650 21,400	6200 13,700	7170 280
-4.5 m -15.0 ft	kg lb			*13 100 *27,950	12 100 26,050					*9550 *20,950	8400 18,900	5820 230



ISO 10567:2007



* Indicates that the load is limited by hydraulic lifting capacity rather than tipping load. The above loads are in compliance with hydraulic excavator lift capacity standard ISO 10567:2007. They do not exceed 87% of hydraulic lifting capacity or 75% of tipping load. Weight of all lifting accessories must be deducted from the above lifting capacities. Lifting capacities are based on the machine standing on a firm, uniform supporting surface. The use of a work tool attachment point to handle/lift objects, could affect the machine lift performance.

Lift capacity stays with ±5% for all available track shoes.

Always refer to the appropriate Operation and Maintenance Manual for specific product information.

330 Hydraulic Excavator Specifications

Bucket Specifications and Compatibility

	Linkage	Undercarriage							Long		Long Narrow	
		Width		Capacity		Weight		Fill	Counterweight		6.7 mt (14,770 lb)	
		mm	in	m ³	yd ³	kg	lb	%	Reach Boom		Reach Boom	
									R3.2 (10'6")	R2.65 (8'8")	R3.2 (10'6")	R2.65 (8'8")
Pin-On (No Quick Coupler)												
General Duty	CB	750	30	0.71	0.93	731	1,611	100	●	●	●	●
	CB	1050	42	1.12	1.46	865	1,906	100	●	●	●	●
	CB	1200	48	1.33	1.74	928	2,047	100	●	●	●	●
	CB	1350	54	1.54	2.02	1011	2,228	100	●	●	●	●
	CB	1500	60	1.76	2.30	1075	2,370	100	●	●	⊙	●
General Duty	CB	600	24	0.52	0.68	659	1,454	100	●	●	●	●
	CB	750	30	0.71	0.93	726	1,601	100	●	●	●	●
	CB	1000	40	1.03	1.35	835	1,841	100	●	●	●	●
	CB	1350	54	1.54	2.02	1005	2,216	100	●	●	●	●
	CB	1500	60	1.76	2.30	1069	2,357	100	●	●	⊙	●
Heavy Duty	CB	1350	54	1.54	2.02	1147	2,528	100	●	●	⊙	●
	CB	1500	60	1.76	2.30	1245	2,745	100	⊙	●	⊖	⊙
Severe Duty	CB	1350	54	1.56	2.04	1239	2,731	90	●	●	●	●
Maximum load with pin-on (payload + bucket)								kg	4605	5045	4200	4610
								lb	10,152	11,122	9,259	10,163
With Pin Grabber Quick Coupler												
General Duty	CB	750	30	0.71	0.93	731	1,611	100	●	●	●	●
	CB	1050	42	1.12	1.46	865	1,906	100	●	●	●	●
	CB	1200	48	1.33	1.74	928	2,047	100	●	●	●	●
	CB	1350	54	1.54	2.02	1011	2,228	100	⊙	●	⊙	⊙
	CB	1500	60	1.76	2.30	1075	2,370	100	⊖	⊙	⊖	⊖
General Duty	CB	600	24	0.52	0.68	659	1,454	100	●	●	●	●
	CB	750	30	0.71	0.93	726	1,601	100	●	●	●	●
	CB	1000	40	1.03	1.35	835	1,841	100	●	●	●	●
	CB	1350	54	1.54	2.02	1005	2,216	100	⊙	●	⊙	●
	CB	1500	60	1.76	2.30	1069	2,357	100	⊙	⊙	⊖	⊙
	CB	1600	63	1.86	2.43	1099	2,423	100	⊖	⊙	○	⊖
Heavy Duty	CB	1350	54	1.54	2.02	1147	2,528	100	⊙	●	⊖	⊙
	CB	1500	60	1.76	2.30	1245	2,745	100	⊖	⊙	○	⊖
Severe Duty	CB	1350	54	1.56	2.04	1239	2,731	90	●	●	⊙	●
Maximum load with coupler (payload + bucket)								kg	4079	4519	3674	4084
								lb	8,992	9,962	8,099	9,003

The above loads are in compliance with hydraulic excavator standard EN474-5:2006 + A3:2013, they do not exceed 87% of hydraulic lifting capacity or 75% of tipping capacity with front linkage fully extended at ground line with bucket curled.

Capacity based on ISO 7451:2007.

Bucket weight with General Duty tips.

Maximum Material Density:

- 2100 kg/m³ (3,500 lb/yd³)
- ⊙ 1800 kg/m³ (3,000 lb/yd³)
- ⊖ 1500 kg/m³ (2,500 lb/yd³)
- 1200 kg/m³ (2,000 lb/yd³)
- X Not Recommended

Caterpillar recommends using appropriate work tools to maximize the value customers receive from our products. Use of work tools, including buckets, which are outside of Caterpillar's recommendations or specifications for weight, dimensions, flows, pressures, etc. may result in less-than-optimal performance, including but not limited to reductions in production, stability, reliability, and component durability. Improper use of a work tool resulting in sweeping, prying, twisting and/or catching of heavy loads will reduce the life of the boom and stick.

(continued on next page)

330 Hydraulic Excavator Specifications

Bucket Specifications and Compatibility (continued)

	Linkage	Undercarriage							Long		Long Narrow	
		Width		Capacity		Weight		Fill	Counterweight		6.7 mt (14,770 lb)	
		mm	in	m ³	yd ³	kg	lb	%	Reach Boom		Reach Boom	
									R3.2 (10'6")	R2.65 (8'8")	R3.2 (10'6")	R2.65 (8'8")
With CW-40 Coupler												
General Duty	CB	750	30	0.71	0.93	634	1,399	100	●	●	●	●
	CB	900	36	0.91	1.19	730	1,610	100	●	●	●	●
	CB	1050	42	1.12	1.46	806	1,777	100	●	●	●	●
	CB	1200	48	1.33	1.74	870	1,918	100	●	●	●	●
	CB	1350	54	1.54	2.02	951	2,097	100	●	●	⊙	●
	CB	1500	60	1.76	2.30	1017	2,242	100	⊙	●	⊖	⊙
Heavy Duty	CB	1050	42	1.12	1.46	945	2,083	100	●	●	●	●
	CB	1350	54	1.54	2.02	1088	2,398	100	●	●	⊙	●
	CB	1650	66	1.97	2.58	1258	2,774	100	⊖	⊙	○	⊖
Severe Duty	CB	1050	42	1.13	1.48	1013	2,233	100	●	●	●	●
	CB	1350	54	1.56	2.04	1201	2,647	100	⊙	●	⊙	●
General Duty Leveling Edge	CB	1200	48	1.29	1.69	894	1,971	100	●	●	●	●
	CB	1300	51	1.44	1.88	960	2,117	100	●	●	●	●
	CB	1400	55	1.57	2.05	1003	2,211	100	●	●	⊙	●
	CB	1500	59	1.71	2.24	1047	2,308	100	⊙	●	⊖	⊙
	CB	1600	63	1.86	2.43	1113	2,453	100	⊙	⊙	⊖	⊙
Maximum load with coupler (payload + bucket)								kg	4312	4752	3907	4317
								lb	9,506	10,476	8,613	9,517
With CW-45 Coupler												
General Duty	CB	1500	60	1.76	2.30	1075	2,370	100	⊙	●	⊖	⊙
	CB	1650	66	1.97	2.58	1159	2,555	100	⊖	⊙	○	⊖
Heavy Duty	CB	1350	54	1.54	2.02	1148	2,530	100	⊙	●	⊖	⊙
	CB	1500	60	1.76	2.30	1245	2,746	100	⊖	⊙	⊖	⊖
	CB	1650	66	1.97	2.58	1318	2,906	100	⊖	⊖	○	⊖
Maximum load with coupler (payload + bucket)								kg	4170	4610	3765	4175
								lb	9,193	10,163	8,300	9,204
With CW-45S Coupler												
General Duty	CB	750	30	0.71	0.93	693	1,529	100	●	●	●	●
	CB	1350	54	1.54	2.02	1009	2,224	100	●	●	⊙	●
	CB	1500	60	1.76	2.30	1074	2,368	100	⊙	●	⊖	⊙
	CB	1050	42	1.12	1.46	948	2,090	100	●	●	●	●
	CB	1350	54	1.54	2.02	1144	2,521	100	⊙	●	⊙	⊙
	CB	1500	60	1.76	2.30	1243	2,741	100	⊖	⊙	⊖	⊖
	CB	1650	66	1.97	2.58	1316	2,902	100	⊖	⊖	○	⊖
Maximum load with coupler (payload + bucket)								kg	4200	4640	3795	4205
								lb	9,259	10,229	8,367	9,270

The above loads are in compliance with hydraulic excavator standard EN474-5:2006 + A3:2013, they do not exceed 87% of hydraulic lifting capacity or 75% of tipping capacity with front linkage fully extended at ground line with bucket curled.

Capacity based on ISO 7451:2007.

Bucket weight with General Duty tips.

Maximum Material Density:

● 2100 kg/m³ (3,500 lb/yd³)

⊙ 1800 kg/m³ (3,000 lb/yd³)

⊖ 1500 kg/m³ (2,500 lb/yd³)

○ 1200 kg/m³ (2,000 lb/yd³)

X Not Recommended

Caterpillar recommends using appropriate work tools to maximize the value customers receive from our products. Use of work tools, including buckets, which are outside of Caterpillar's recommendations or specifications for weight, dimensions, flows, pressures, etc. may result in less-than-optimal performance, including but not limited to reductions in production, stability, reliability, and component durability. Improper use of a work tool resulting in sweeping, prying, twisting and/or catching of heavy loads will reduce the life of the boom and stick.

330 Hydraulic Excavator Specifications

Attachments Offering Guide

Not all Attachments are available in all regions. Consult your Cat dealer for configurations available in your region.

Match

* Working range front only

No Match

PIN-ON ATTACHMENTS

Undercarriage		L		LN	
Counterweight		6.7 mt (14,770 lb)		6.7 mt (14,770 lb)	
Boom Type		Reach		Reach	
Stick Length		2.65 m (8'8")	3.2 m (10'6")	2.65 m (8'8")	3.2 m (10'6")
Hydraulic Hammers	H120 S	✓	✓	✓	✓
	H130 GC S	✓	✓	✓	✓
	H130 S	✓	✓	✓	✓
	H140 GC S	✓	✓	✓	✓
	H140 S	✓	✓	✓	✓
	H160 GC S	✓	✓	✓	✓
Multi-Processors	MP324 Concrete Cutter Jaw	✓	✓	✓	✓
	MP324 Demolition Jaw	✓	✓	✓	✓
	MP324 Pulverizer Jaw	✓	✓	✓	✓
	MP324 Shear Jaw	✓	✓	✓	✓
	MP324 Tank Shear Jaw	✓	✓	✓	✓
	MP324 Universal Jaw	✓	✓	✓	✓
	MP332 Concrete Cutter Jaw	✓	✓	✓	✓
	MP332 Demolition Jaw	✓	✓	✓	✓*
	MP332 Pulverizer Jaw	✓	✓	✓	✓*
	MP332 Shear Jaw	✓	✓	✓	✓
	MP332 Tank Shear Jaw	✓	✓*	✓*	
	MP332 Universal Jaw	✓	✓	✓	✓*
Demolition and Sorting Grapples	G324	✓	✓	✓	✓
	G324 WH-1500	✓	✓	✓	✓
	G324 WH-1800	✓	✓	✓	✓
	G324 WH-2000	✓	✓	✓	✓
	G332	✓	✓	✓	✓
Mobile Scrap & Demolition Shears	S3025	✓	✓	✓	✓
	S3025 Flat Top	✓	✓	✓	✓
	S3035	✓	✓	✓	✓
	S3035 Flat Top	✓	✓	✓	✓
Pulverizers	P224 Secondary Pulverizer	✓	✓	✓	✓
	P324 Primary Pulverizer	✓	✓	✓	✓
	P332 Primary Pulverizer	✓	✓	✓	✓
Compactors (Vibratory Plate)	CVP110	✓	✓	✓	✓

(continued on next page)

330 Hydraulic Excavator Specifications

Attachments Offering Guide *(continued)*

Not all Attachments are available in all regions. Consult your Cat dealer for configurations available in your region.

1800 kg/m³ (3,000 lb/yd³)

1200 kg/m³ (2,000 lb/yd³)

No Match

PIN-ON ATTACHMENTS

Undercarriage		L		LN		
		6.7 mt (14,770 lb)		6.7 mt (14,770 lb)		
Counterweight		Reach		Reach		
Boom Type		2.65 m (8'8")		3.2 m (10'6")		
Stick Length		2.65 m (8'8")	3.2 m (10'6")	2.65 m (8'8")	3.2 m (10'6")	
Orange Peel Grapples	GSH425-750	●	●	●	●	
	GSH425-950	●	●	●	●	
	GSH425-1150	●	●	●	●	
	GSH440-1150	●	●	●	○	
	GSH440-1550	○	○	○		
	GSH525-750	●	●	●	●	
	GSH525-950	●	●	●	●	
	GSH525-1150	●	●	●	○	
	GSV525-600	●	●	●	●	
	GSV525-750	●	●	●	●	
	GSV525-950	●	●	●	●	
	GSV525-1150	●	●	●	●	
	Hydraulic Transfer Grab	CTV15-1000	●	●	●	●
		CTV15-1200	●	●	●	●
		CTV15-1500	●	●	●	○
CTV15-1700		●	○	○	○	
CTV15-1900		○	○	○	○	
CTV15-2300		○				
CTV20-1300		●	●	●	○	
CTV20-1500		●	○	○	○	
CTV20-1700		○	○	○	○	
CTV20-1900		○	○	○		

(continued on next page)

330 Hydraulic Excavator Specifications

Attachments Offering Guide (continued)

Not all Attachments are available in all regions. Consult your Cat dealer for configurations available in your region.

Match
 * Working range front only
 † Allowed usage on machine less than 50%
 No Match

CAT PIN GRABBER COUPLER ATTACHMENTS

Undercarriage		L		LN	
		6.7 mt (14,770 lb)		6.7 mt (14,770 lb)	
Counterweight		Reach Boom		Reach Boom	
Boom Type		2.65 m (8'8")		3.2 m (10'6")	
Stick Length		2.65 m (8'8")	3.2 m (10'6")	2.65 m (8'8")	3.2 m (10'6")
Hydraulic Hammers	H120 S	✓	✓	✓	✓
	H130 GC S	✓	✓	✓	✓
	H130 S	✓	✓	✓	✓
	H140 GC S	✓	✓	✓	✓*
	H140 S	✓	✓	✓	✓
	H160 GC S	✓	✓	✓	✓
Multi-Processors	MP324 Concrete Cutter Jaw	✓	✓	✓	✓
	MP324 Demolition Jaw	✓	✓	✓	✓
	MP324 Pulverizer Jaw	✓	✓	✓	✓
	MP324 Shear Jaw	✓	✓	✓	✓
	MP324 Tank Shear Jaw	✓	✓	✓	✓
	MP324 Universal Jaw	✓	✓	✓	✓
	MP332 Concrete Cutter Jaw	✓	✓*	✓*	
	MP332 Demolition Jaw	✓			
	MP332 Pulverizer Jaw	✓			
	MP332 Shear Jaw	✓	✓*	✓*	
	MP332 Universal Jaw	✓			
	Demolition and Sorting Grapples	G324	✓	✓†	✓
G324 WH-1500		✓	✓†	✓	✓†
G324 WH-1800		✓	✓†	✓	✓†*
G324 WH-2000		✓		✓*	
G332		✓	✓†	✓	✓†*
Mobile Scrap and Demolition Shears	S3025	✓	✓	✓	✓
	S3025 Flat Top	✓	✓	✓	✓
	S3035	✓	✓	✓	✓*
	S3035 Flat Top	✓		✓*	
Compactors (Vibratory Plate)	CVP110	✓	✓	✓	✓

(continued on next page)

330 Hydraulic Excavator Specifications

Attachments Offering Guide (continued)

Not all Attachments are available in all regions. Consult your Cat dealer for configurations available in your region.

Match
 * Working range front only
 † Allowed usage on machine less than 50%
 No Match

CW-45s DEDICATED COUPLER ATTACHMENTS

Undercarriage		L		LN	
Counterweight		6.7 mt (14,770 lb)		6.7 mt (14,770 lb)	
Boom Type		Reach		Reach	
Stick Length		2.65 m (8'8")	3.2 m (10'6")	2.65 m (8'8")	3.2 m (10'6")
Hydraulic Hammers	H120 S	✓	✓	✓	✓
	H130 GC S	✓	✓	✓	✓
	H130 S	✓	✓	✓	✓
	H140 GC S	✓	✓	✓	
	H140 S	✓	✓	✓	✓
	H160 GC S	✓	✓	✓	✓
Multi-Processors	MP324 Concrete Cutter Jaw	✓	✓	✓	✓
	MP324 Demolition Jaw	✓	✓	✓	✓
	MP324 Pulverizer Jaw	✓	✓	✓	✓
	MP324 Shear Jaw	✓	✓	✓	✓
	MP324 Tank Shear Jaw	✓	✓	✓	✓
	MP324 Universal Jaw	✓	✓	✓	✓
	MP332 Concrete Cutter Jaw	✓	✓*	✓*	
	MP332 Demolition Jaw	✓	✓*	✓*	
	MP332 Pulverizer Jaw	✓		✓*	
	MP332 Shear Jaw	✓	✓	✓	
	MP332 Tank Shear Jaw	✓*			
	MP332 Universal Jaw	✓		✓*	
Demolition and Sorting Grapples	G324	✓	✓†	✓	✓†
	G324 WH-1500	✓	✓†	✓	✓†
	G324 WH-1800	✓	✓†	✓	✓†*
	G324 WH-2000	✓	✓†*	✓*	
	G332	✓	✓†	✓	✓†*
Mobile Scrap and Demolition Shears	S3025	✓	✓	✓	✓
	S3025 Flat Top	✓	✓	✓	✓
	S3035	✓		✓*	
	S3035 Flat Top	✓		✓*	
Pulverizers	P224 Secondary Pulverizer	✓	✓	✓	✓
	P232 Secondary Pulverizer	✓*			
	P324 Primary Pulverizer	✓	✓	✓	✓
	P332 Primary Pulverizer	✓	✓*	✓*	
	P332 Primary Pulverizer-Flat Top	✓*			
Compactors (Vibratory Plate)	CVP110	✓	✓	✓	✓

(continued on next page)

330 Hydraulic Excavator Specifications

Attachments Offering Guide *(continued)*

Not all Attachments are available in all regions. Consult your Cat dealer for configurations available in your region.

Match
 * Working range front only
 † Allowed usage on machine less than 50%
 No Match

CW-45 DEDICATED COUPLER ATTACHMENTS

Undercarriage		L		LN	
Counterweight		6.7 mt (14,770 lb)		6.7 mt (14,770 lb)	
Boom Type		Reach		Reach	
Stick Length		2.65 m (8'8")	3.2 m (10'6")	2.65 m (8'8")	3.2 m (10'6")
Hydraulic Hammers	H120 S	✓	✓	✓	✓
	H130 GC S	✓	✓	✓	✓
	H130 S	✓	✓	✓	✓
	H140 GC S	✓	✓	✓	✓*
	H140 S	✓	✓	✓	✓
	H160 GC S	✓	✓	✓	✓
Multi-Processors	MP324 Concrete Cutter Jaw	✓	✓	✓	✓
	MP324 Demolition Jaw	✓	✓	✓	✓
	MP324 Pulverizer Jaw	✓	✓	✓	✓
	MP324 Shear Jaw	✓	✓	✓	✓
	MP324 Tank Shear Jaw	✓	✓	✓	✓
	MP324 Universal Jaw	✓	✓	✓	✓
	MP332 Concrete Cutter Jaw	✓	✓*	✓*	
	MP332 Demolition Jaw	✓		✓*	
	MP332 Pulverizer Jaw	✓			
	MP332 Shear Jaw	✓	✓*	✓*	
	MP332 Universal Jaw	✓			
Demolition and Sorting Grapples	G324	✓	✓†	✓	✓†
	G324 WH-1500	✓	✓†	✓	✓†
	G324 WH-1800	✓	✓†	✓	✓†*
	G324 WH-2000	✓	✓†*	✓*	
	G332	✓	✓†	✓	✓†*
Mobile Scrap and Demolition Shears	S3025	✓	✓	✓	✓
	S3025 Flat Top	✓	✓	✓	✓
	S3035	✓		✓*	
	S3035 Flat Top	✓		✓*	
Pulverizers	P224 Secondary Pulverizer	✓	✓	✓	✓
	P232 Secondary Pulverizer	✓*			
	P324 Primary Pulverizer	✓	✓	✓	✓
	P332 Primary Pulverizer	✓		✓*	
	P332 Primary Pulverizer-Flat Top	✓*			
Compactors (Vibratory Plate)	CVP110	✓	✓	✓	✓

(continued on next page)

330 Hydraulic Excavator Specifications

Attachments Offering Guide *(continued)*

Not all Attachments are available in all regions. Consult your Cat dealer for configurations available in your region.

Match
 * Working range front only
 † Allowed usage on machine less than 50%

S70 DEDICATED COUPLER ATTACHMENTS

Undercarriage		L		LN	
Counterweight		6.7 mt (14,770 lb)		6.7 mt (14,770 lb)	
Boom Type		Reach		Reach	
Stick Length		2.65 m (8'8")	3.2 m (10'6")	2.65 m (8'8")	3.2 m (10'6")
Hydraulic Hammers	H120 S	✓	✓	✓	✓
	H130 S	✓	✓	✓	✓
	H140 S	✓	✓	✓	✓
Multi-Processors	MP324 Concrete Cutter Jaw	✓	✓	✓	✓
	MP324 Demolition Jaw	✓	✓	✓	✓
	MP324 Pulverizer Jaw	✓	✓	✓	✓
	MP324 Shear Jaw	✓	✓	✓	✓
	MP324 Tank Shear Jaw	✓	✓	✓	✓
	MP324 Universal Jaw	✓	✓	✓	✓
Demolition and Sorting Grapples	G324	✓	✓†	✓	✓†
	G324 WH-1500	✓	✓†	✓	✓†
	G324 WH-1800	✓	✓†	✓	✓†
	G324 WH-2000	✓	✓†	✓	✓†*
	G332	✓	✓†	✓	✓†
Mobile Scrap and Demolition Shears	S3025 Flat Top	✓	✓	✓	✓
	S3035 Flat Top	✓	✓	✓	✓*
Pulverizers	P224 Secondary Pulverizer	✓	✓	✓	✓
	P324 Primary Pulverizer	✓	✓	✓	✓
Compactors (Vibratory Plate)	CVP110	✓	✓	✓	✓

(continued on next page)

330 Hydraulic Excavator Specifications

Attachments Offering Guide (continued)

Not all Attachments are available in all regions. Consult your Cat dealer for configurations available in your region.

Match
 * Working range front only
 † Allowed usage on machine less than 50%
 No Match

S80 DEDICATED COUPLER ATTACHMENTS

Undercarriage		L		LN	
Counterweight		6.7 mt (14,770 lb)		6.7 mt (14,770 lb)	
Boom Type		Reach		Reach	
Stick Length		2.65 m (8'8")	3.2 m (10'6")	2.65 m (8'8")	3.2 m (10'6")
Hydraulic Hammers	H120 S	✓	✓	✓	✓
	H130 GC S	✓	✓	✓	✓
	H130 S	✓	✓	✓	✓
	H140 GC S	✓	✓	✓	✓*
	H140 S	✓	✓	✓	✓
	H160 GC S	✓	✓	✓	✓
Multi-Processors	MP324 Concrete Cutter Jaw	✓	✓	✓	✓
	MP324 Demolition Jaw	✓	✓	✓	✓
	MP324 Pulverizer Jaw	✓	✓	✓	✓
	MP324 Shear Jaw	✓	✓	✓	✓
	MP324 Tank Shear Jaw	✓	✓	✓	✓
	MP324 Universal Jaw	✓	✓	✓	✓
	MP332 Concrete Cutter Jaw	✓*			
	MP332 Demolition Jaw	✓*			
	MP332 Pulverizer Jaw	✓*			
	MP332 Shear Jaw	✓			
MP332 Universal Jaw	✓*				
Demolition and Sorting Grapples	G324	✓	✓†	✓	✓†
	G324 WH-1500	✓	✓†	✓	✓†
	G324 WH-1800	✓	✓†	✓	✓†*
	G324 WH-2000	✓	✓†*	✓*	
	G332	✓	✓†	✓	✓†*
Mobile Scrap and Demolition Shears	S3025 Flat Top	✓	✓	✓	✓
	S3035 Flat Top	✓		✓*	
Pulverizers	P224 Secondary Pulverizer	✓	✓	✓	✓
	P232 Secondary Pulverizer	✓*			
	P324 Primary Pulverizer	✓	✓	✓	✓
	P332 Primary Pulverizer-Flat Top	✓*			
Compactors (Vibratory Plate)	CVP110	✓	✓	✓	✓

(continued on next page)

330 Hydraulic Excavator Specifications

Attachments Offering Guide *(continued)*

Not all Attachments are available in all regions. Consult your Cat dealer for configurations available in your region.

Match
 * Working range front only
 † Allowed usage on machine less than 50%
 No Match

HCS70 DEDICATED COUPLER ATTACHMENTS

Undercarriage		L		LN	
Counterweight		6.7 mt (14,770 lb)		6.7 mt (14,770 lb)	
Boom Type		Reach		Reach	
Stick Length		2.65 m (8'8")	3.2 m (10'6")	2.65 m (8'8")	3.2 m (10'6")
Hydraulic Hammers	H120 S	✓	✓	✓	✓
	H130 S	✓	✓	✓	✓
	H140 S	✓	✓	✓	✓
Multi-Processors	MP324 Concrete Cutter Jaw	✓	✓	✓	✓
	MP324 Demolition Jaw	✓	✓	✓	✓
	MP324 Pulverizer Jaw	✓	✓	✓	✓
	MP324 Shear Jaw	✓	✓	✓	✓
	MP324 Tank Shear Jaw	✓	✓	✓	✓
	MP324 Universal Jaw	✓	✓	✓	✓
Demolition and Sorting Grapples	G324	✓	✓†	✓	✓†
	G324 WH-1500	✓	✓†	✓	✓†
	G324 WH-1800	✓	✓†	✓	✓†*
	G324 WH-2000	✓	✓†	✓*	
	G332	✓	✓†	✓	✓†*
Mobile Scrap and Demolition Shears	S3025 Flat Top	✓	✓	✓	✓
	S3035 Flat Top	✓		✓*	
Pulverizers	P224 Secondary Pulverizer	✓	✓	✓	✓
	P324 Primary Pulverizer	✓	✓	✓	✓
Compactors (Vibratory Plate)	CVP110	✓	✓	✓	✓

(continued on next page)

330 Hydraulic Excavator Specifications

Attachments Offering Guide *(continued)*

Not all Attachments are available in all regions. Consult your Cat dealer for configurations available in your region.

Match
 * Working range front only
 † Allowed usage on machine less than 50%
 No Match

HCS70/55 DEDICATED COUPLER ATTACHMENTS

Undercarriage		L		LN	
		6.7 mt (14,770 lb)		6.7 mt (14,770 lb)	
Counterweight		Reach		Reach	
		2.65 m (8'8")	3.2 m (10'6")	2.65 m (8'8")	3.2 m (10'6")
Boom Type		Reach		Reach	
Stick Length		2.65 m (8'8")	3.2 m (10'6")	2.65 m (8'8")	3.2 m (10'6")
Hydraulic Hammers	H120 S	✓	✓	✓	✓
	H130 S	✓	✓	✓	✓
	H140 S	✓	✓	✓	✓
Multi-Processors	MP324 Concrete Cutter Jaw	✓	✓	✓	✓
	MP324 Demolition Jaw	✓	✓	✓	✓
	MP324 Pulverizer Jaw	✓	✓	✓	✓
	MP324 Shear Jaw	✓	✓	✓	✓
	MP324 Tank Shear Jaw	✓	✓	✓	✓
	MP324 Universal Jaw	✓	✓	✓	✓
Demolition and Sorting Grapples	G324	✓	✓†	✓	✓†
	G324 WH-1500	✓	✓†	✓	✓†
	G324 WH-1800	✓	✓†	✓	✓†*
	G324 WH-2000	✓	✓†*	✓*	
	G332	✓	✓†	✓	✓†*
Mobile Scrap and Demolition Shears	S3025 Flat Top	✓	✓	✓	✓
	S3035 Flat Top	✓		✓*	
Pulverizers	P224 Secondary Pulverizer	✓	✓	✓	✓
	P324 Primary Pulverizer	✓	✓	✓	✓
Compactors (Vibratory Plate)	CVP110	✓	✓	✓	✓

(continued on next page)

330 Hydraulic Excavator Specifications

Attachments Offering Guide *(continued)*

Not all Attachments are available in all regions. Consult your Cat dealer for configurations available in your region.

Match
 * Working range front only
 † Allowed usage on machine less than 50%
 No Match

HCS80 DEDICATED COUPLER ATTACHMENTS

Undercarriage		L		LN	
		6.7 mt (14,770 lb)		6.7 mt (14,770 lb)	
Counterweight		Reach		Reach	
		2.65 m (8'8")	3.2 m (10'6")	2.65 m (8'8")	3.2 m (10'6")
Boom Type		Reach		Reach	
Stick Length		2.65 m (8'8")	3.2 m (10'6")	2.65 m (8'8")	3.2 m (10'6")
Hydraulic Hammers	H120 S	✓	✓	✓	✓
	H130 S	✓	✓	✓	✓
	H140 S	✓	✓	✓	✓
Multi-Processors	MP324 Concrete Cutter Jaw	✓	✓	✓	✓
	MP324 Demolition Jaw	✓	✓	✓	✓
	MP324 Pulverizer Jaw	✓	✓	✓	✓*
	MP324 Shear Jaw	✓	✓	✓	✓
	MP324 Tank Shear Jaw	✓	✓	✓	✓
	MP324 Universal Jaw	✓	✓	✓	✓
	MP332 Concrete Cutter Jaw	✓*			
	MP332 Shear Jaw	✓*			
Demolition and Sorting Grapples	G324	✓	✓†	✓	✓†
	G324 WH-1500	✓	✓†	✓	✓†
	G324 WH-1800	✓	✓†	✓	
	G324 WH-2000	✓		✓*	
	G332	✓	✓†	✓	✓†*
Mobile Scrap and Demolition Shears	S3025 Flat Top	✓	✓	✓	✓
	S3035 Flat Top	✓		✓*	
Pulverizers	P224 Secondary Pulverizer	✓	✓	✓	✓*
	P232 Secondary Pulverizer	✓*			
	P324 Primary Pulverizer	✓	✓	✓	✓*
Compactors (Vibratory Plate)	CVP110	✓	✓	✓	✓

(continued on next page)

330 Hydraulic Excavator Specifications

Attachments Offering Guide *(continued)*

Not all Attachments are available in all regions. Consult your Cat dealer for configurations available in your region.

Match

TRS23 (PIN-ON TOP/CW-40 BOTTOM) ATTACHMENTS

Undercarriage		L		LN	
Counterweight		6.7 mt (14,770 lb)		6.7 mt (14,770 lb)	
Boom Type		Reach		Reach	
Stick Length		2.65 m (8'8")	3.2 m (10'6")	2.65 m (8'8")	3.2 m (10'6")
Hydraulic Hammers	H120 S	✓	✓	✓	✓
	H130 GC S	✓	✓	✓	✓
	H130 S	✓	✓	✓	✓
Compactors (Vibratory Plate)	CVP110	✓	✓	✓	✓

NOTE: Hammer on tiltrotator usage less than 10% of working hours. Refer to your OMM for recommended hydraulic flow requirements.

TRS23 (CW-40 TOP/CW-40 BOTTOM) ATTACHMENTS

Undercarriage		L		LN	
Counterweight		6.7 mt (14,770 lb)		6.7 mt (14,770 lb)	
Boom Type		Reach		Reach	
Stick Length		2.65 m (8'8")	3.2 m (10'6")	2.65 m (8'8")	3.2 m (10'6")
Compactors (Vibratory Plate)	CVP110	✓	✓	✓	✓

TRS23 (PIN-ON TOP/CW-45S BOTTOM) ATTACHMENTS

Undercarriage		L		LN	
Counterweight		6.7 mt (14,770 lb)		6.7 mt (14,770 lb)	
Boom Type		Reach		Reach	
Stick Length		2.65 m (8'8")	3.2 m (10'6")	2.65 m (8'8")	3.2 m (10'6")
Hydraulic Hammers	H120 S	✓	✓	✓	✓
	H130 GC S	✓	✓	✓	✓
	H130 S	✓	✓	✓	✓
Compactors (Vibratory Plate)	CVP110	✓	✓	✓	✓

NOTE: Hammer on tiltrotator usage less than 10% of working hours. Refer to your OMM for recommended hydraulic flow requirements.

(continued on next page)

330 Hydraulic Excavator Specifications

Attachments Offering Guide (continued)

Not all Attachments are available in all regions. Consult your Cat dealer for configurations available in your region.

Match

* Working range front only

TRS23 (CW-45S TOP/CW-45S BOTTOM) ATTACHMENTS

Undercarriage		L		LN	
Counterweight		6.7 mt (14,770 lb)		6.7 mt (14,770 lb)	
Boom Type		Reach		Reach	
Stick Length		2.65 m (8'8")	3.2 m (10'6")	2.65 m (8'8")	3.2 m (10'6")
Hydraulic Hammers	H120 S	✓	✓	✓	✓
	H130 GC S	✓		✓*	
	H130 S	✓	✓	✓	✓
Compactors (Vibratory Plate)	CVP110	✓	✓	✓	✓

NOTE: Hammer on tiltrotator usage less than 10% of working hours. Refer to your OMM for recommended hydraulic flow requirements.

TRS23 (PIN-ON TOP/S70 BOTTOM) ATTACHMENTS

Undercarriage		L		LN	
Counterweight		6.7 mt (14,770 lb)		6.7 mt (14,770 lb)	
Boom Type		Reach		Reach	
Stick Length		2.65 m (8'8")	3.2 m (10'6")	2.65 m (8'8")	3.2 m (10'6")
Hydraulic Hammers	H120 S	✓	✓	✓	✓
	H130 S	✓	✓	✓	✓
Compactors (Vibratory Plate)	CVP110	✓	✓	✓	✓

NOTE: Hammer on tiltrotator usage less than 10% of working hours. Refer to your OMM for recommended hydraulic flow requirements.

TRS23 (S70 TOP/S70 BOTTOM) ATTACHMENTS

Undercarriage		L		LN	
Counterweight		6.7 mt (14,770 lb)		6.7 mt (14,770 lb)	
Boom Type		Reach		Reach	
Stick Length		2.65 m (8'8")	3.2 m (10'6")	2.65 m (8'8")	3.2 m (10'6")
Hydraulic Hammers	H120 S	✓	✓	✓	✓
	H130 S	✓	✓	✓	✓
Compactors (Vibratory Plate)	CVP110	✓	✓	✓	✓

NOTE: Hammer on tiltrotator usage less than 10% of working hours. Refer to your OMM for recommended hydraulic flow requirements.

330 Hydraulic Excavator Specifications

Attachments Offering Guide (continued)

Not all Attachments are available in all regions. Consult your Cat dealer for configurations available in your region.

Match

TRS23 (PIN-ON TOP/S80 BOTTOM) ATTACHMENTS

Undercarriage		L		LN	
Counterweight		6.7 mt (14,770 lb)		6.7 mt (14,770 lb)	
Boom Type		Reach		Reach	
Stick Length		2.65 m (8'8")	3.2 m (10'6")	2.65 m (8'8")	3.2 m (10'6")
Hydraulic Hammers	H120 S	✓	✓	✓	✓
	H130 GC S	✓	✓	✓	✓
	H130 S	✓	✓	✓	✓
Compactors (Vibratory Plate)	CVP110	✓	✓	✓	✓

NOTE: Hammer on tiltrotator usage less than 10% of working hours. Refer to your OMM for recommended hydraulic flow requirements.

TRS23 (S80 TOP/S80 BOTTOM) ATTACHMENTS

Undercarriage		L		LN	
Counterweight		6.7 mt (14,770 lb)		6.7 mt (14,770 lb)	
Boom Type		Reach		Reach	
Stick Length		2.65 m (8'8")	3.2 m (10'6")	2.65 m (8'8")	3.2 m (10'6")
Hydraulic Hammers	H120 S	✓	✓	✓	✓
	H130 GC S	✓	✓	✓	
	H130 S	✓	✓	✓	✓
Compactors (Vibratory Plate)	CVP110	✓	✓	✓	✓

NOTE: Hammer on tiltrotator usage less than 10% of working hours. Refer to your OMM for recommended hydraulic flow requirements.

TRS23 (HCS70 TOP/HCS70 BOTTOM) ATTACHMENTS

Undercarriage		L		LN	
Counterweight		6.7 mt (14,770 lb)		6.7 mt (14,770 lb)	
Boom Type		Reach		Reach	
Stick Length		2.65 m (8'8")	3.2 m (10'6")	2.65 m (8'8")	3.2 m (10'6")
Hydraulic Hammers	H120 S	✓	✓	✓	✓
	H130 S	✓	✓	✓	✓
Compactors (Vibratory Plate)	CVP110	✓	✓	✓	✓

NOTE: Hammer on tiltrotator usage less than 10% of working hours. Refer to your OMM for recommended hydraulic flow requirements.

330 Hydraulic Excavator Specifications

Attachments Offering Guide (continued)

Not all Attachments are available in all regions. Consult your Cat dealer for configurations available in your region.

Match

* Working range front only

TRS23 (HCS70/55 TOP/HCS70/55 BOTTOM) ATTACHMENTS

Undercarriage		L		LN	
Counterweight		6.7 mt (14,770 lb)		6.7 mt (14,770 lb)	
Boom Type		Reach		Reach	
Stick Length		2.65 m (8'8")	3.2 m (10'6")	2.65 m (8'8")	3.2 m (10'6")
Hydraulic Hammers	H120 S	✓	✓	✓	✓
	H130 S	✓	✓	✓	✓
Compactors (Vibratory Plate)	CVP110	✓	✓	✓	✓

NOTE: Hammer on tiltrotator usage less than 10% of working hours. Refer to your OMM for recommended hydraulic flow requirements.

TRS23 (HCS70/55 TOP/HCS70/55 BOTTOM) ATTACHMENTS

Undercarriage		L		LN	
Counterweight		6.7 mt (14,770 lb)		6.7 mt (14,770 lb)	
Boom Type		Reach		Reach	
Stick Length		2.65 m (8'8")	3.2 m (10'6")	2.65 m (8'8")	3.2 m (10'6")
Hydraulic Hammers	H120 S	✓	✓	✓	✓
	H130 S	✓	✓	✓	✓
Compactors (Vibratory Plate)	CVP110	✓	✓	✓	✓

NOTE: Hammer on tiltrotator usage less than 10% of working hours. Refer to your OMM for recommended hydraulic flow requirements.

TRS23 (HCS80 TOP/HCS80 BOTTOM) ATTACHMENTS

Undercarriage		L		LN	
Counterweight		6.7 mt (14,770 lb)		6.7 mt (14,770 lb)	
Boom Type		Reach		Reach	
Stick Length		2.65 m (8'8")	3.2 m (10'6")	2.65 m (8'8")	3.2 m (10'6")
Hydraulic Hammers	H120 S	✓	✓	✓	✓
	H130 S	✓	✓	✓	✓*
Compactors (Vibratory Plate)	CVP110	✓	✓	✓	✓

NOTE: Hammer on tiltrotator usage less than 10% of working hours. Refer to your OMM for recommended hydraulic flow requirements.

BOOM-MOUNT ATTACHMENTS

Undercarriage		L		LN	
Counterweight		6.7 mt (14,770 lb)		6.7 mt (14,770 lb)	
Boom Type		Reach		Reach	
Mobile Scrap and Demolition Shears	S2070	✓		✓	
	S3050	✓		✓	
	S3050 Flat Top	✓		✓	

Standard and Optional Equipment

Standard and optional equipment may vary. Consult your Cat dealer for details.

	Standard	Optional		Standard	Optional
CAT TECHNOLOGY			ENGINE		
Cat Product Link™	✓		Three selectable modes: Power, Smart, Eco	✓	
Work tool recognition	✓		Automatic engine speed control	✓	
Work tool tracking*	✓		Automatic engine idle-shutdown	✓	
Laser catcher		✓	4500 m (14,760 ft) altitude capability with engine power derate above 3000 m (9,840 ft)	✓	
Cat Grade with 2D and offset memory	✓		50° C (122° F) high-ambient cooling capability with derate	✓	
Cat Grade with Advanced 2D		✓	-18° C (0° F) cold start capability	✓	
Cat Grade with 3D connectivity:	✓		-32° C (-25° F) cold start capability		✓
– Compatibility with radios and base stations from Trimble, Topcon, and Leica			2 × 115 amp dual alternator	✓	
– Capability to install 3D grade systems from Trimble, Topcon, and Leica			Sealed double element air filter with integrated precleaner	✓	
Cat Assist:	✓		Two-stage fuel filtration with water separator and indicator	✓	
– Grade Assist			Electric fuel priming pump	✓	
– Boom Assist			Electric cooling fans with auto-reverse function	✓	
– Bucket Assist			HYDRAULIC SYSTEM		
– Swing Assist			Electronic main control valve	✓	
– Lift Assist			Electric boom regeneration circuit	✓	
Cat Payload:	✓		Stick regeneration circuit	✓	
– Static weigh			Automatic hydraulic oil warm up	✓	
– Semiautomatic calibration			Automatic two-speed travel	✓	
– Payload/cycle information			Boom and stick drift reduction valve	✓	
– USB reporting capability			Boom lowering check valve	✓	
2D E-Fence:	✓		Stick lowering check valve	✓	
– E-ceiling			Auto Dig Boost	✓	
– E-floor			Auto heavy lift	✓	
– E-swing			Smart boom	✓	
– E-wall			High performance hydraulic return filter	✓	
– E-cab avoidance			Final drive with bio hydraulic oil capable travel motor	✓	
Auto hammer stop	✓		Advanced Tool Control (two pump, one/two way high-pressure flow)	✓	
Remote Services capability	✓		Medium-pressure circuit		✓
			Common Quick Coupler Circuit for Cat Pin Grabber and CW Dedicated		✓

*Paired with PL161 attachment locator.

(continued on next page)

330 Standard and Optional Equipment

Standard and Optional Equipment (continued)

Standard and optional equipment may vary. Consult your Cat dealer for details.

	Standard	Optional		Standard	Optional
BOOM, STICKS AND LINKAGE			SERVICE AND MAINTENANCE		
6.15 m (20'2") Reach boom	✓		Grouped location of engine oil and fuel filters	✓	
3.2 m (10'6") Reach stick, CB2 Linkage		✓	Ground-level second dipstick for engine oil	✓	
2.65 m (8'8") Reach stick, CB2 Linkage		✓	Side entry to service platform	✓	
Bucket Linkage, CB2 family with lifting eye, Cat Grade	✓		Scheduled Oil Sampling (S-O-S SM) ports	✓	
UNDERCARRIAGE AND STRUCTURES			QuickEvac™ maintenance ready		✓
Long undercarriage		✓	Electric refueling pump with automatic shutoff	✓	
Long narrow undercarriage		✓	Radiator screen		✓
Full-length track guiding guards		✓	SAFETY AND SECURITY		
Segmented track guiding guards	✓		Rearview camera	✓	
Swivel guard	✓		Right-hand-sideview camera	✓	
HD bottom guard	✓		360° visibility		✓
HD travel motor guard	✓		Secure start with PIN code	✓	
Grease lubricated track	✓		Caterpillar One Key security system	✓	
Swing drive and motor, and swing bearing for higher swing torque	✓		Lockable external tool/storage box	✓	
Base frame with HD rollers	✓		Lockable door, fuel, and hydraulic tank locks	✓	
Tie-down points on base frame	✓		Lockable fuel drain compartment	✓	
6700 kg (14,770 lb) counterweight	✓		Service platform with anti-skid plate and recessed bolts	✓	
600 mm (24") triple grouser track shoes		✓	RH handrail and hand hold (ISO 2867:2011 compliant)	✓	
600 mm (24") triple grouser HD track shoes		✓	Cab mirror for RH track edge	✓	
700 mm (28") triple grouser HD track shoes		✓	Signaling/warning horn	✓	
800 mm (31") triple grouser track shoes		✓	Ground-level secondary engine shutoff switch in cab	✓	
900 mm (35") triple grouser track shoes		✓	Hydraulic lock out lever that neutralizes all controls	✓	
ELECTRICAL SYSTEM					
Maintenance-free 1,000 CCA batteries (×2)	✓				
Programmable time-delay LED working lights	✓				
Centralized electrical disconnect switch	✓				
LED chassis light, LH and RH boom lights, cab lights	✓				
Premium surround lighting package	✓				

Dealer Installed Kits and Attachments

Attachments may vary. Consult your Cat dealer for details.

CAB

- LH/RH electrical pedal (two-way) for tool control
- Radial lower wiper for two piece (70/30) windshield, with washer
- Rain protector plus cab light cover

SAFETY AND SECURITY

- Bluetooth® key fob

GUARDS

- Side rubber bumper guard
- Falling object guard system (not compatible with cab light cover, rain protector)
- Mesh guard full front (not compatible with cab light cover, rain protector)
- Mesh guard lower half front

ELECTRICAL

- Jump start wiring

SERVICE AND MAINTENANCE

- Grease gun holder

330 Cab Options

Cab Options

	Deluxe	Premium
ROPS, standard sound suppression	●	X
ROPS, advanced sound suppression	X	●
High-resolution 254 mm (10") LCD touchscreen monitor (only for use with 360° visibility)	●	●
High-resolution 254 mm (10") LCD touchscreen monitor + additional monitor (only for use with Cat Grade with Advanced 2D or Cat Grade with 3D)	○	○
Height-adjustable console, infinite with no tool	●	●
Tilt-up left-side console	●	●
Cat Stick Steer	○	○
Heated seat with air-adjustable suspension	●	X
Heated and cooled seat with automatic adjustable suspension	X	●
Automatic bi-level air conditioner	●	●
Jog dial and shortcut keys for monitor control	●	●
Keyless push-to-start engine control	●	●
51 mm (2") seat belt	●	●
Bluetooth integrated radio with USB ports	●	●
12V DC outlets	●	●
Document storage	●	●
Rear head storage net and lunchbox storage net	●	●
Cup and bottle holders	●	●
Openable two-piece front window	●	●
Fixed one-piece front window	X	○
Upper radial wiper with washer	●	X
Parallel wiper with washer	X	●
Openable polycarbonate skylight hatch	●	●
Fixed glass skylight hatch	X	○
LED dome light	●	●
Floor welcome light	●	●
Roller rear sunscreen	○	●
Rear window emergency exit	●	●
Washable floor mat	●	●
Beacon ready	●	●

● Standard

○ Optional

X Not available

The following information applies to the machine at the time of final manufacture as configured for sale in the regions covered in this document. The content of this declaration is valid as of the date issued; however, content related to machine features and specifications are subject to change without notice. For additional information, please see the machine's Operation and Maintenance Manual.

For more information on sustainability in action and our progress, please visit <https://www.caterpillar.com/en/company/sustainability>.

Engine

- The Cat® C7.1 engine meets U.S. EPA Tier 4 Final, EU Stage V, Japan 2014, and Korea Tier 5 emission standards.
- Cat diesel engines are required to use ULSD (ultra-low sulfur diesel fuel with 15 ppm of sulfur or less) or ULSD blended with the following lower-carbon intensity fuels up to:
 - ✓ 20% biodiesel FAME (fatty acid methyl ester)*
 - ✓ 100% renewable diesel, HVO (hydrogenated vegetable oil) and GTL (gas-to-liquid) fuels

Refer to guidelines for successful application. Please consult your Cat dealer or “Caterpillar Machine Fluids Recommendations” (SEBU6250) for details.

**Engines with no aftertreatment devices can use higher blends, up to 100% biodiesel.*

Air Conditioning System

- The air conditioning system on this machine contains the fluorinated greenhouse gas refrigerant R134a (Global Warming Potential = 1430). The system contains 0.9 kg (1.9 lb) of refrigerant which has a CO2 equivalent of 1.287 metric tonnes (1.418 tons).

Paint

- Based on best available knowledge, the maximum allowable concentration, measured in parts per million (PPM), of the following heavy metals in paint are:
 - Barium < 0.01%
 - Cadmium < 0.01%
 - Chromium < 0.01%
 - Lead < 0.01%

Sound Performance

ISO 6395:2008 (external) 103 dB(A)

ISO 6396:2008 (inside cab) 70 dB(A)

- Hearing protection may be needed when operating with an open operator station and cab (when not properly maintained or doors/windows open) for extended periods or in a noisy environment.

Oils and Fluids

- Caterpillar factory fills with ethylene glycol coolants. Cat Diesel Engine Antifreeze/Coolant (DEAC) and Cat Extended Life Coolant (ELC) can be recycled. Consult your Cat dealer for more information.
- Cat Bio HYDO Advanced is an EU Ecolabel approved biodegradable hydraulic oil.
- Additional fluids are likely to be present, please consult the Operations and Maintenance Manual or the Application and Installation guide for complete fluid recommendations and maintenance intervals.

Features and Technology

- The following features and technology may contribute to fuel savings and/or carbon reduction. Features may vary. Consult your Cat dealer for details.
 - Advanced hydraulic systems balance power and efficiency
 - Smart mode matches machine power to digging requirements automatically
 - Increase operating efficiency up to 45% with standard Cat technologies that lower operator fatigue and operating costs
 - Cut maintenance costs up to 25% as compared to the 330F
 - New hydraulic oil filter provides longer life with a 3,000-hour replacement interval – 50% longer than previous filter designs
 - One-touch low idle with automatic engine speed control

Recycling

- The materials included in machines are categorized as below with approximate weight percentage. Because of variations of product configurations, the following values in the table may vary.

Material Type	Weight Percentage
Steel	86.85%
Iron	4.63%
Nonferrous Metal	1.55%
Mixed Metal	0.07%
Mixed-Metal and Nonmetal	0.63%
Plastic	1.79%
Rubber	0.16 %
Mixed Nonmetallic	0.23%
Fluid	3.12%
Other	0.96%
Uncategorized	0.00%
Total	100%

- A machine with higher recyclability rate will ensure more efficient usage of valuable natural resources and enhance End-of-Life value of the product. According to ISO 16714 (Earthmoving machinery – Recyclability and recoverability – Terminology and calculation method), recyclability rate is defined as percentage by mass (mass fraction in percent) of the new machine potentially able to be recycled, reused, or both.

All parts in the bill of material are first evaluated by component type based on a list of components defined by the ISO 16714 and Japan CEMA (Construction Equipment Manufacturers Association) standards. Remaining parts are further evaluated for recyclability based on material type.

Because of variations of product configurations, the following value in the table may vary.

Recyclability – 97%

For more complete information on Cat products, dealer services, and industry solutions, visit us on the web at www.cat.com

© 2022 Caterpillar
All rights reserved

Materials and specifications are subject to change without notice. Featured machines in photos may include additional equipment. See your Cat dealer for available options.

CAT, CATERPILLAR, LET'S DO THE WORK, their respective logos, "Caterpillar Corporate Yellow," the "Power Edge" and Cat "Modern Hex" trade dress as well as corporate and product identity used herein, are trademarks of Caterpillar and may not be used without permission.

AEXJ0081-05 (7-2022)
Replaces AEXJ0081-04
Build Number: 07D
(Europe)

