



Cat[®] 740 GC

ARTICULATED TRUCK

FEATURES:

- **World Class Cab** – Designed from extensive worldwide operator interviews, surveys and forums, the new cab offers 20 percent more interior space and a quieter cab at 72 dB(A).
- **Engine** – Cat[®] C15 ACERT[™] engine meets either U.S. EPA Tier 2/EU Stage II or U.S. EPA Tier 3/EU Stage IIIA equivalent. EU Stage 5/V due 2019.
- **Transmission** – CX38B High Density Power Shift (HDPS) Transmission featuring Advanced Productivity Electronic Control Strategy (APECS). Nine forward/two reverse gears incorporate many new features including reduced weight and improved performance, while maintaining durability.
- **Combined Hoist/Transmission Lever** – The new innovative and unique operator control incorporates park brake activation and release, also introduces Assisted Hoist Control with both fully automatic and manual modes. Up to 50 percent less operator actions required.
- **Automatic Climate Control System** – Create a more comfortable operator space with finer control over in-cab temperature.
- **Automatic Retarder Control (ARC)** – When engaged, control of the retarder is managed entirely by the machine. No operator input is required.
- **Seat Belt Indicator** – Audible and visible alert if operator seat belt is not worn.
- **Operator Presence Switch** – Machine will not engage gear without operator being seated.
- **Emergency Brake Switch** – Brings the machine to a safe stop in the unlikely event of both main and secondary brake circuits failing. The “tertiary brakes” are applied through a red mushroom button that is not on the combined lever. The parking brakes should not be suggested to be used as emergency brakes.
- **Economy Mode** – Provides an average 5 percent reduction on fuel consumption.
- **Cat Detect With Stability Assist** – Audible and visual alert to operator if the tractor and/or trailer unit is approaching a pre-set angle during operation stopping the dump process if continued action might potentially result in tipping.
- **Terrain Based Throttle Control** – Smoothens throttle input over rough terrain to improve ride quality.
- **Advanced Automatic Traction Control** – Proactively applies differential lock to prevent wheel spin.
- **Directional Shift Protection** – Protects the power train when quickly changing gear from Reverse to Forward or Forward to Reverse.
- **Durable Flexi Fender** – Prevents permanent damage and reduces repair costs.
- **Touchscreen Information Display** – Monitor and configure machine options and view feed from rear view camera.
- **Machine Wake Up** – Initiates machine systems at ground level or when cab door is opened.
- **Low Profile Exhaust Stack** – Reduces overall height and eliminates the need to remove the exhaust stack for transport.
- **Improved Door** – Increased visibility with more glass surface area and 36 percent lighter to ease opening and closing.
- **Integrated Payload Lights (when Cat Payload Monitoring option is fitted)** – Wide angle beam lights on all cab roof corners provide clear visibility to loading tool operator and site controllers.
- **Cab Mounted Mirrors** – Excellent visibility, reduced vibration and easily folded.
- **Front Visibility Mirror** – Gives clear view immediately in front of the machine.
- **Redesigned Cab Structure** – Increases glass area improving rear quarter visibility when reversing.
- **Sliding Windows (left and right)** – Improved ventilation and communication.
- **Large Storage Areas** – Side storage box can be cooled or heated by Heating Ventilation Air Conditioning. Twin cup holders, hard hat hook and smaller storage pockets are all included.

740 GC Articulated Truck

Specifications

Engine

Engine Model	C15 ACERT	
Gross Power – SAE J1995	335 kW	449 hp
Net Power – SAE J1349	324 kW	434 hp
Net Power – ISO 14396	330 kW	443 hp
Bore	137 mm	5.4 in
Stroke	171.5 mm	6.75 in
Displacement	15.2 L	926 in ³
No Engine De-rating Required Below	3050 m	10,000 ft
Peak Engine Torque Gross (SAE J1995)	2320 N·m	1,711 lb-ft
Peak Engine Torque Net (ISO 14396)	2264 N·m	1,670 lb-ft
Peak Engine Torque Speed	1,200 rpm	

Body Capacities

Rated Payload	36.3 tonnes	40 tons
Heaped SAE 2:1	22.7 m ³	29.7 yd ³
Struck	17 m ³	22.7 yd ³

Transmission

Forward 1	6.4 km/h	4 mph
Forward 2	8.5 km/h	5.3 mph
Forward 3	11.8 km/h	7.3 mph
Forward 4	14.8 km/h	9.2 mph
Forward 5	19.7 km/h	12.2 mph
Forward 6	24 km/h	14.9 mph
Forward 7	33.1 km/h	20.6 mph
Forward 8	39.8 km/h	24.7 mph
Forward 9	57.5 km/h	35.7 mph
Reverse 1	6.8 km/h	4.2 mph
Reverse 2	15.7 km/h	9.8 mph

Sound Levels

Interior Cab	72 dB(A)
--------------	----------

Operating Weights

Front Axle – Empty	18 761 kg	41,361 lb
Center Axle – Empty	6709 kg	14,791 lb
Rear Axle – Empty	6486 kg	14,299 lb
Total – Empty	31 956 kg	70,451 lb
Front Axle – Rated Load	3233 kg	7,128 lb
Center Axle – Rated Load	16 534 kg	36,451 lb
Rear Axle – Rated Load	16 534 kg	36,451 lb
Total – Rated Load	36 301 kg	80,030 lb
Front Axle – Loaded	21 994 kg	48,488 lb
Center Axle – Loaded	23 243 kg	51,242 lb
Rear Axle – Loaded	23 020 kg	50,750 lb
Total – Loaded	68 257 kg	150,480 lb

Fill Capacities

Fuel Tank	550 L	145.3 gal
Cooling System	90 L	23.7 gal
Brake Cooling Tank	67 L	17.7 gal
Steering/Hoist Hydraulic System	140 L	36.9 gal
Engine Crankcase	52 L	13.7 gal
Transmission/Output Transfer Gear	75 L	19.8 gal
Final Drives (each)	5 L	1.3 gal
Axles (each)	60 L	15.8 gal

740 GC Articulated Truck

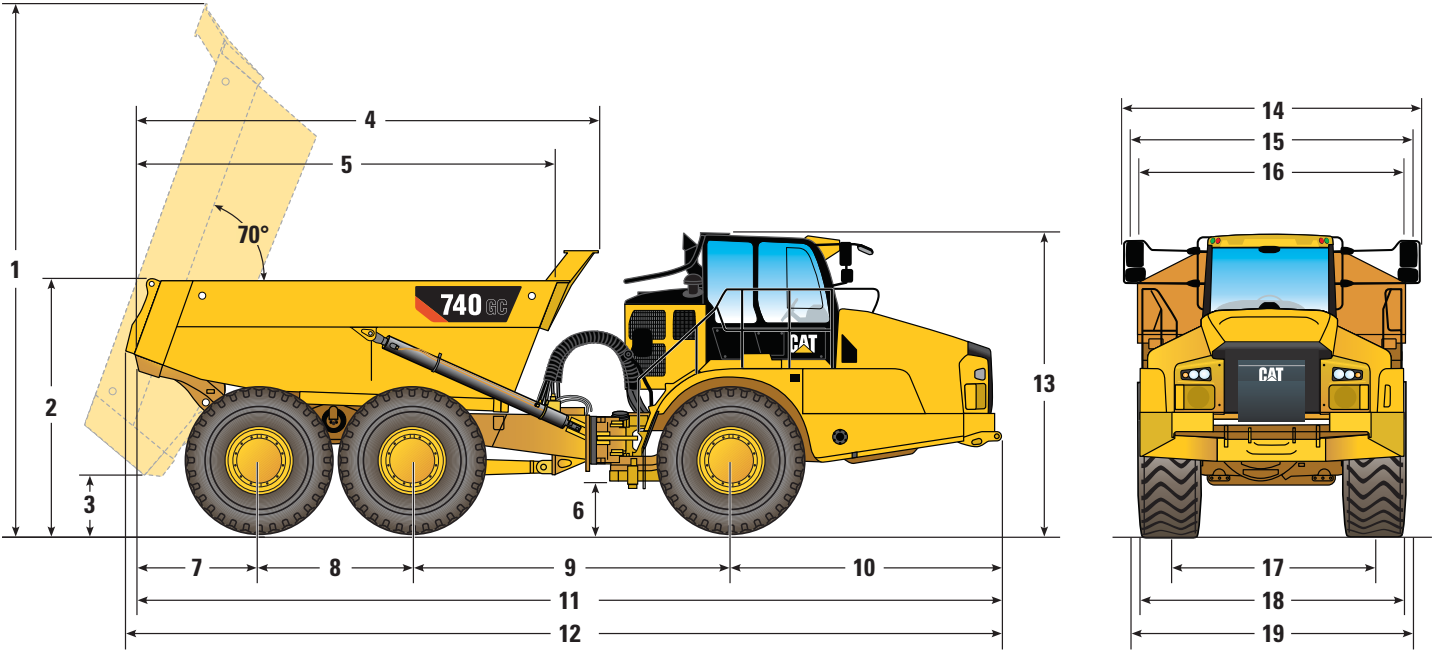

Dimensions
(All dimensions are approximate.)

	mm	ft/in		mm	ft/in
1	6736	22'1"	11*	11 052	36'3"
2	3202	10'6"	12**	11 173	36'7"
3	684	2'2"	13	3757	12'3"
4	5962	19'5"	14	3801	12'4"
5	5426	17'8"	15***	3647	12'0"
6	588	1'9"	16****	3422	11'2"
7	1542	5'1"	17†	2687	8'9"
8	1966	6'5"	18††	3370	11'1"
9	4126	13'6"	19†††	3500	11'5"
10	3418	11'2"			

- * Overall Length
- ** Overall Length with Tailgate
- *** With Tailgate
- **** Body Width
- † Track Width
- †† Over Fenders
- ††† Maximum Laden over Tire Bulge

740 GC Articulated Truck

For more complete information on Cat products, dealer services, and industry solutions, visit us on the web at www.cat.com

© 2018 Caterpillar
All rights reserved

Materials and specifications are subject to change without notice. Featured machines in photos may include additional equipment. See your Cat dealer for available options.

CAT, CATERPILLAR, SAFETY.CAT.COM, their respective logos, "Caterpillar Yellow" and the "Power Edge" trade dress, as well as corporate and product identity used herein, are trademarks of Caterpillar and may not be used without permission.

AEHQ8160 (09-2018)
Build Number: 04A
(LRC)

